

THIS DRAWING IS UNPUBLISHED. RELEASED FOR PUBLICATION 20  
 © COPYRIGHT 20 BY - ALL RIGHTS RESERVED.

LOC	DIST	REVISIONS			
P	LTR	DESCRIPTION	DATE	DWN	APVD
DY	-	A3	REVISED PER ECO-17-018044	01NOV2017	R.L H.L

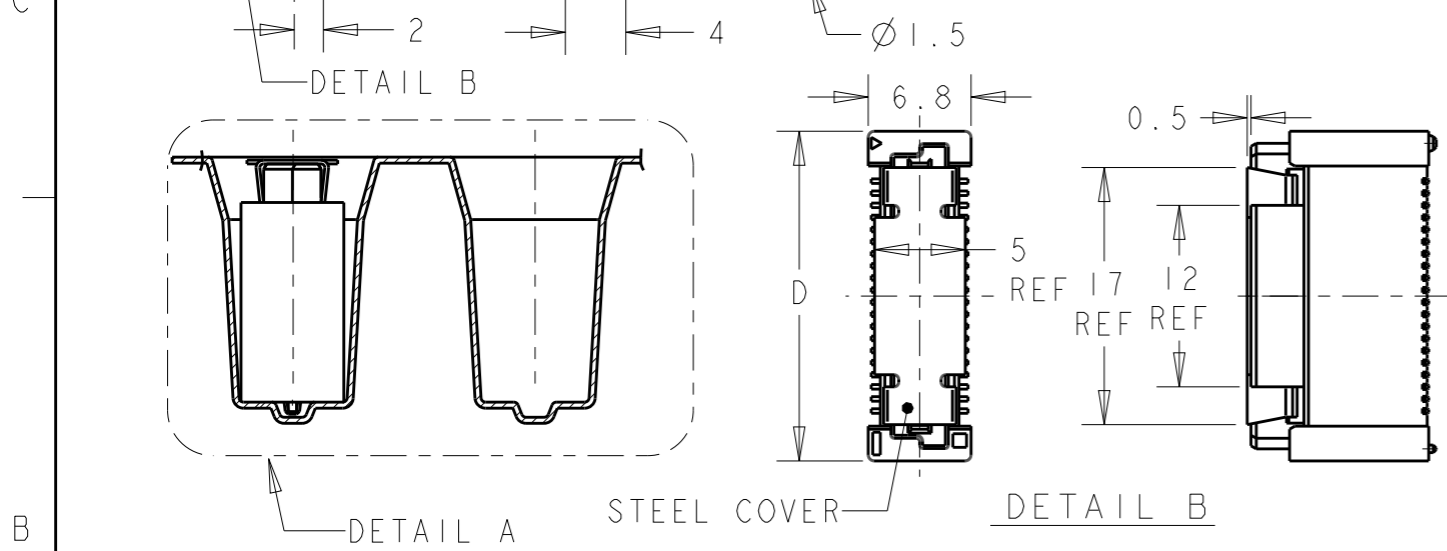
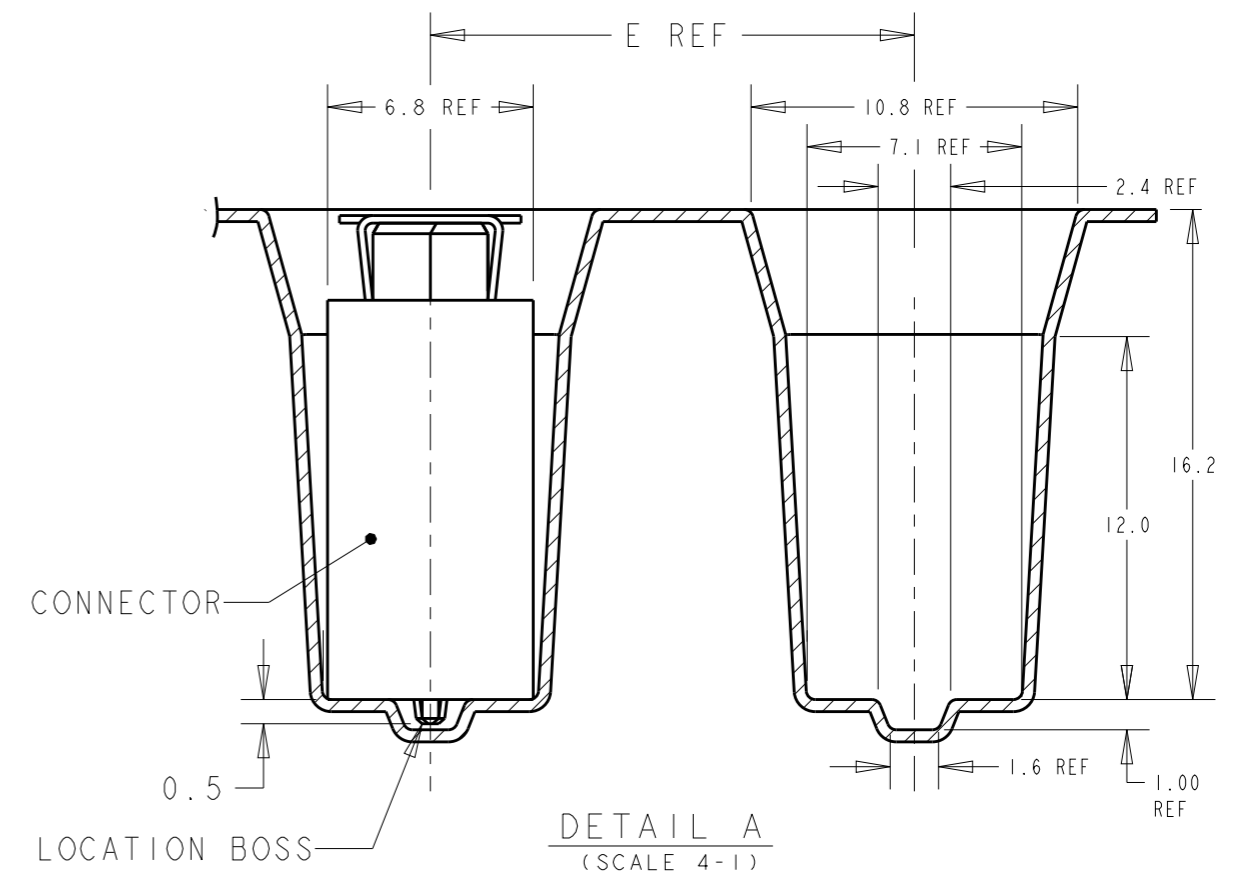
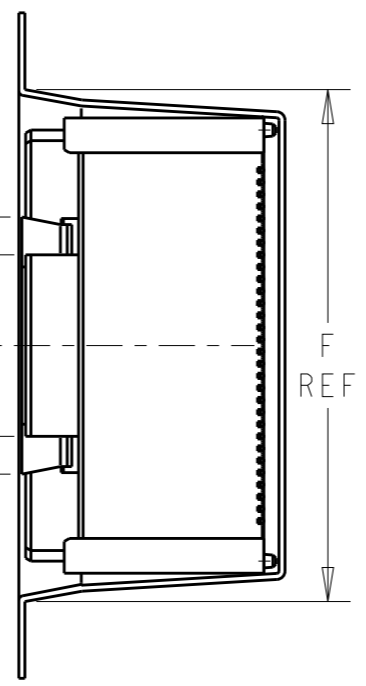
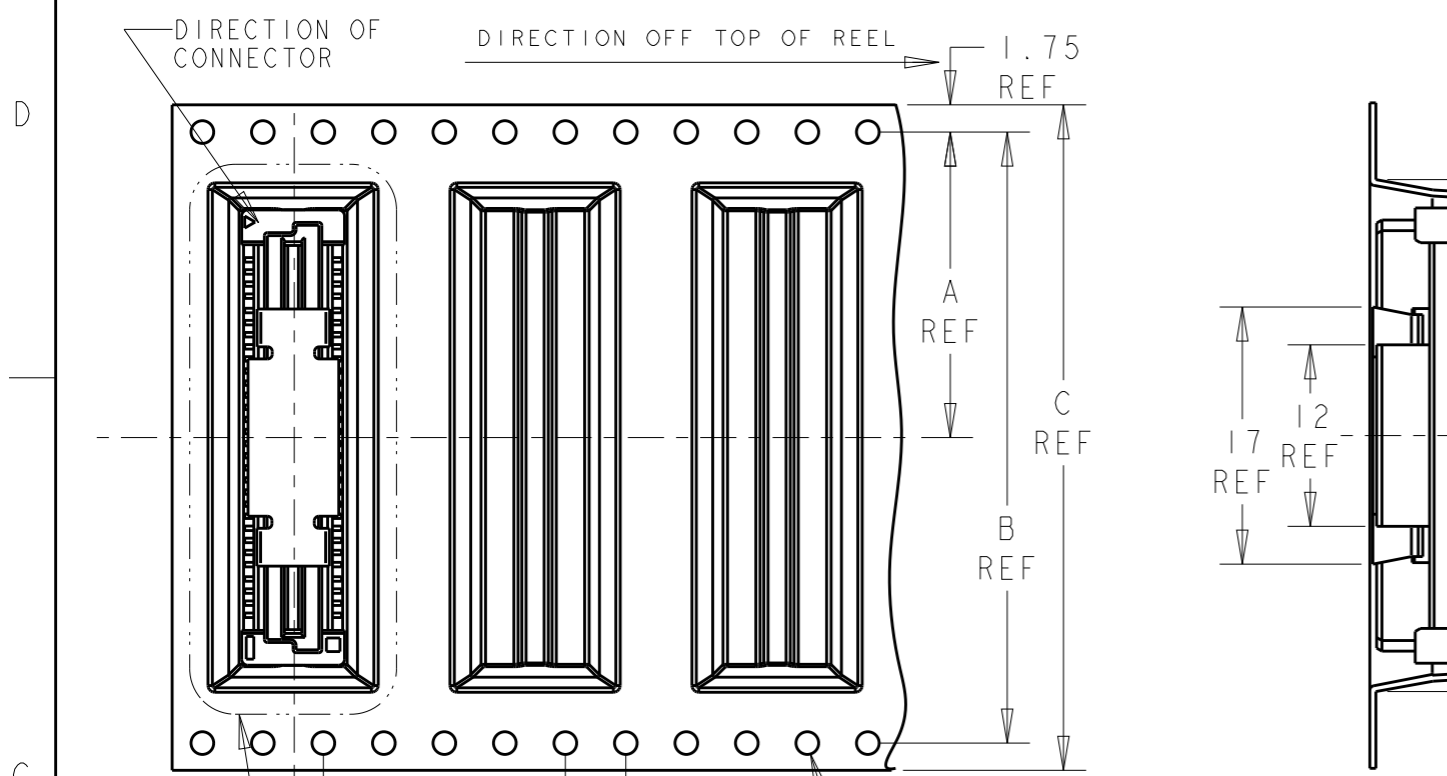

NOTES:

- MATERIALS:  
HOUSING: L.C.P (HIGH TEMP THERMO PLASTIC) UL 94V-0, NATURAL.  
CONTACT: COPPER ALLOY.
- FINISH:  
ENGAGEMENT AREA: 0.0002 MIN GOLD  
SOLDERING AREA: 0.002 MIN MATTE TIN  
UNDERCOAT: 0.0013 MIN NICKEL ALL OVER
- FINISH:  
ENGAGEMENT AREA: 0.00076 MIN GOLD  
SOLDERING AREA: 0.002 MIN MATTE TIN  
UNDERCOAT: 0.0013 MIN NICKEL ALL OVER
- POSITION SERIES:  
SEE P/N TABLE ON SHEET 3.
- CONNECTOR MATED STACKED HEIGHT IS COMBINATION OF PLUG HEIGHT "Y" AND REC HEIGHT "X", LESS 5 mm.  
STACKED HEIGHT = Y + X - 5
- THIS DRAWING 1735481 DESCRIBES CONNECTORS P/N X-1735480-X WITH STEEL COVER IN EMBOSS TAPE PACKAGING.  
CONNECTOR DIMENSIONS (ON SHEET 2) AND RECOMMENDED P.C. BOARD LAYOUT (ON SHEET 3) ARE REFERENCED FROM DRAWING 1735480.

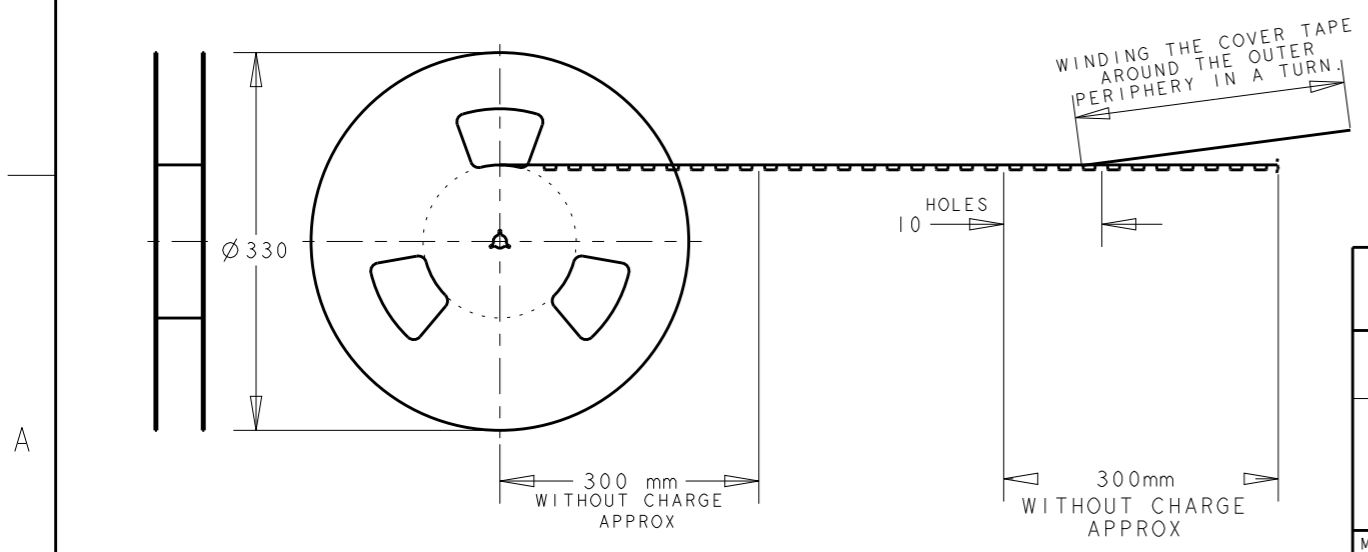

THIS DRAWING IS A CONTROLLED DOCUMENT.		DWN RITA LIANG 01NOV17	TE Connectivity	
DIMENSIONS: mm		CHK SHOAL ALEX 23NOV17		
TOLERANCES UNLESS OTHERWISE SPECIFIED:		APVD HOPE LU 23NOV17	NAME	
0 PLC ±-	1 PLC ±0.30	PRODUCT SPEC 108-5390	RECEPTACLE 17mm HEIGHT FH 0.8mm B-T-B CONNECTOR WITH STEEL COVER, ON EMBOSS TAPE	
2 PLC ±0.25	3 PLC ±0.20	APPLICATION SPEC 114-5254	SIZE A3	CAGE CODE 00779
4 PLC ±-	ANGLES ±3°	WEIGHT -	DRAWING NO C-1735482	
MATERIAL	FINISH SEE P/N TABLE	CUSTOMER DRAWING	RESTRICTED TO	
		SCALE 2:1	SHEET 1 OF 3	REV A3

4

3

2

1

THIS DRAWING IS UNPUBLISHED. RELEASED FOR PUBLICATION 20  
 © COPYRIGHT 20 BY - ALL RIGHTS RESERVED.

LOC	DIST	REVISIONS			
P	LTR	DESCRIPTION	DATE	DWN	APVD
DY	-	SEE SHEET 1	-	-	-

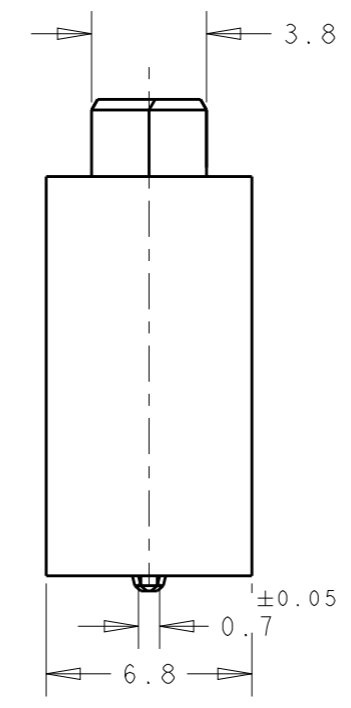
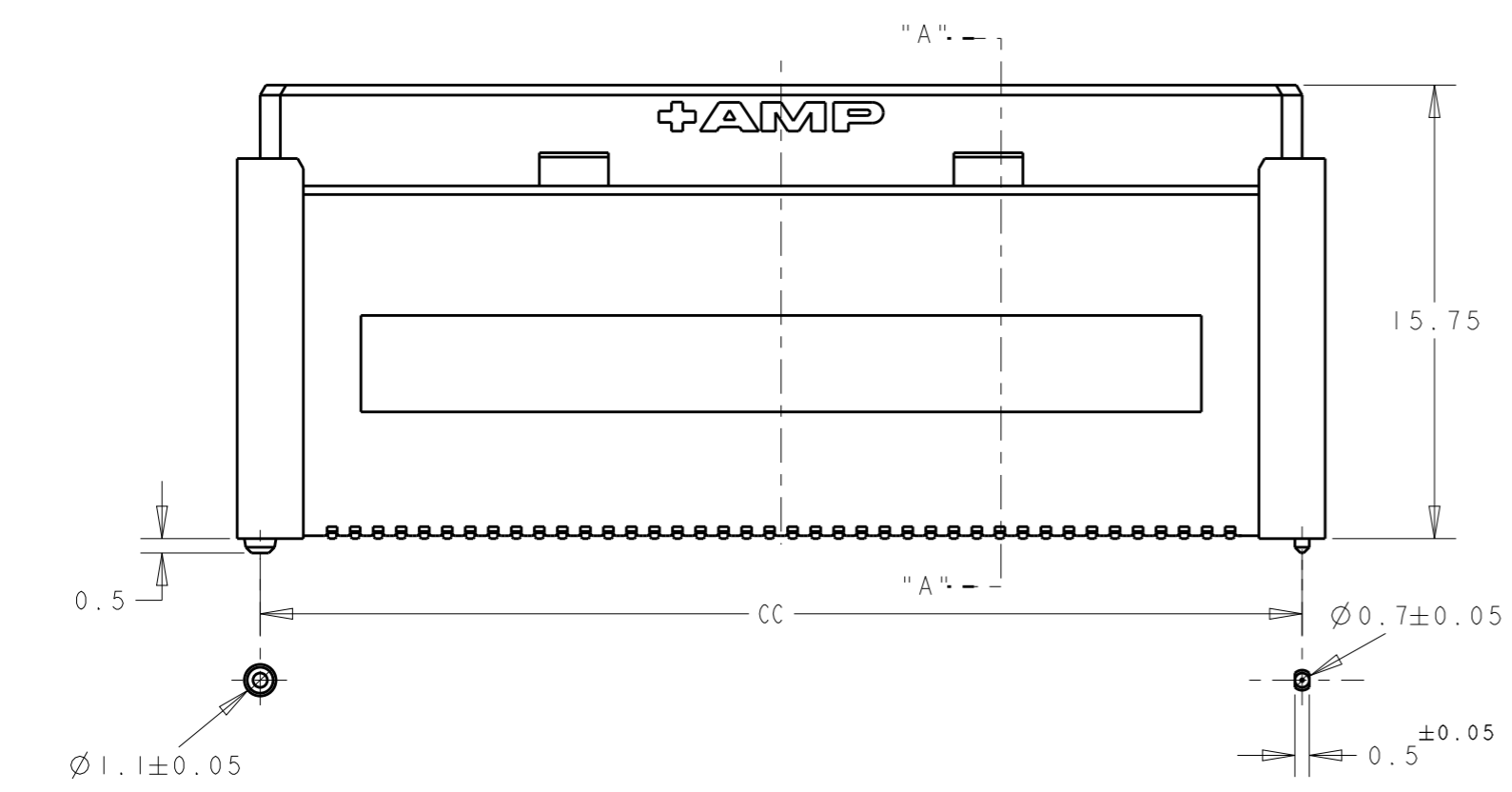
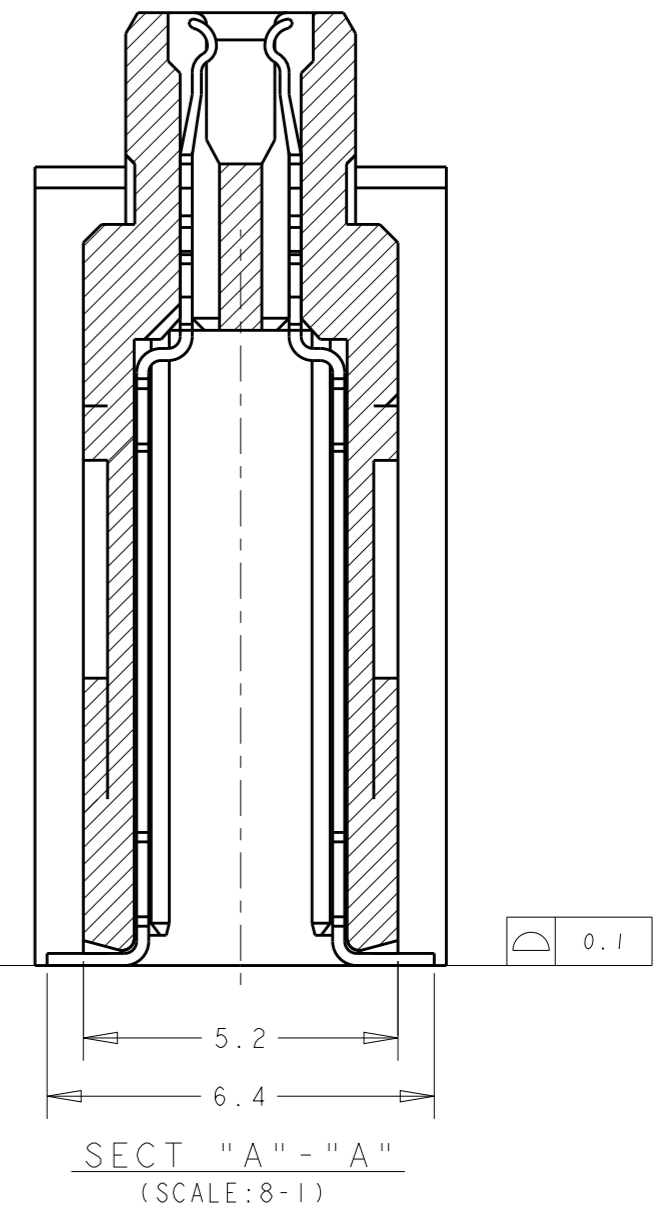
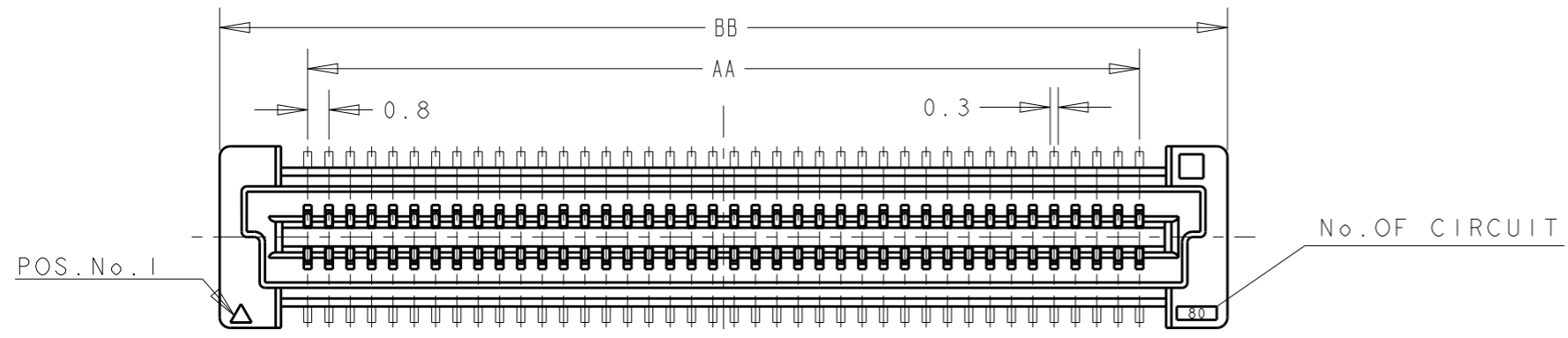

CONNECTOR DIMENSIONS REFERENCED FROM DRAWING NO. 1735480.

THIS DRAWING IS A CONTROLLED DOCUMENT.		DWN RITA LIANG 01NOV17	 TE Connectivity	
DIMENSIONS: mm		CHK SHOAL ALEX 23NOV17		
TOLERANCES UNLESS OTHERWISE SPECIFIED:		APVD HOPE LU 23NOV17	NAME RECEPTACLE 17mm HEIGHT FH 0.8mm B-T-B CONNECTOR WITH STEEL COVER, ON EMBOSS TAPE	
0 PLC ± 1 PLC ±0.30 2 PLC ±0.25 3 PLC ±0.20 4 PLC ± ANGLES ±3°		PRODUCT SPEC 108-5390	SIZE A3	
MATERIAL		APPLICATION SPEC 114-5254	CAGE CODE 00779	DRAWING NO 1735482
FINISH SEE P/N TABLE		WEIGHT -	RESTRICTED TO -	
		CUSTOMER DRAWING	SCALE 2:1	SHEET 2 OF 3
			REV A3	

THIS DRAWING IS UNPUBLISHED.

RELEASED FOR PUBLICATION

20

© COPYRIGHT 20 BY -

ALL RIGHTS RESERVED.

LOC  
DY

DIST  
-

REVISIONS

P	LTR	DESCRIPTION	DATE	DWN	APVD
-	-	SEE SHEET 1	-	-	-

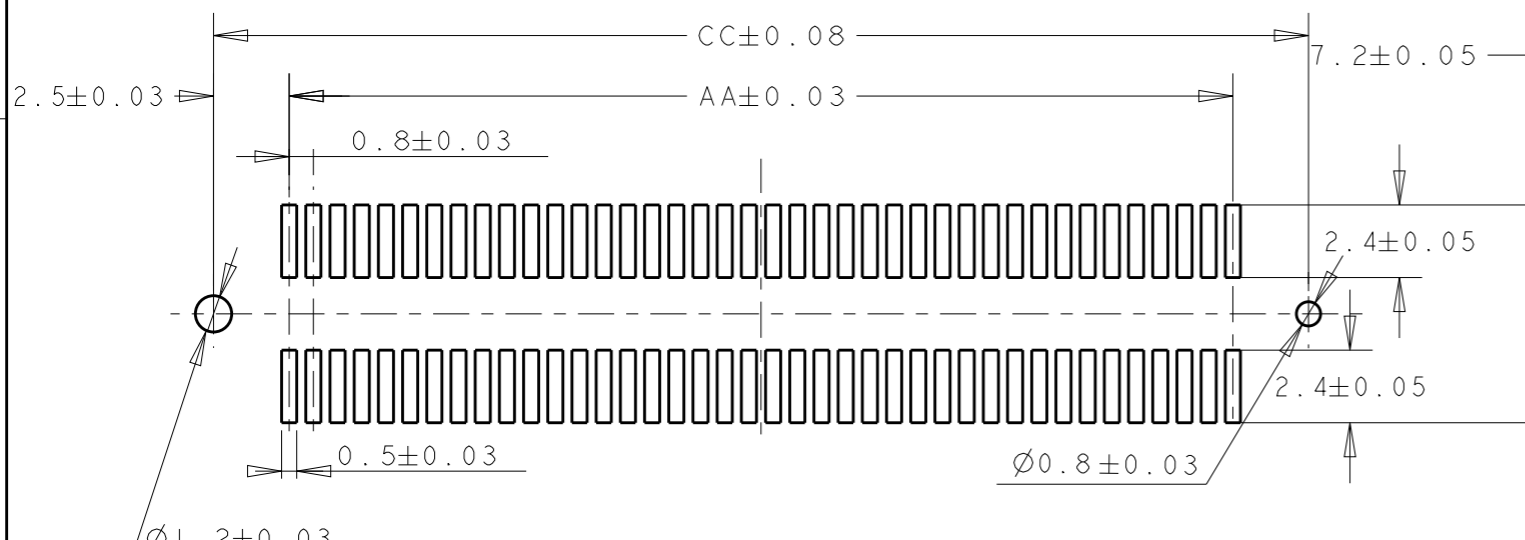

RECOMMENDED P.C. BOARD LAYOUT  
(REFERENCED FROM DRAWING NO. 1735480.)

NOTES:

- A3** FINISH: GOLD FLASH
- ENGAGEMENT AREA: 0.002 MIN MATTE TIN
- SOLDERING AREA: 0.0013 MIN NICKEL
- UNDERCOAT: ALL OVER

**A3**

CONTACT FINISH	QTY	CC	BB	AA	F	E	D	C	B	A	POS	SALEABLE PART NO.
Gold flash - Sn <b>7</b>	100	84.20	SAME AS DIM D	79.20	94.0	20	85.8	120	116.4	58.2	200	4-1735482-0
	100	76.20		71.20	86.0	20	77.8	104	100.4	50.2	180	3-1735482-9
	100	68.20		63.20	73.8	20	69.8	88	84.4	42.2	160	3-1735482-8
	100	64.20		59.20	69.8	20	65.8	88	84.4	42.2	150	3-1735482-7
	100	60.20		55.20	65.8	20	61.8	88	84.4	42.2	140	3-1735482-6
	100	52.20		47.20	57.8	20	53.8	72	68.4	34.2	120	3-1735482-5
	100	44.20		39.20	49.8	20	45.8	72	68.4	34.2	100	3-1735482-4
	100	36.20		31.20	41.8	20	37.8	56	52.4	26.2	80	3-1735482-3
	100	28.20		23.20	33.8	20	29.8	44	40.4	20.2	60	3-1735482-2
	100	20.20		15.20	25.8	20	21.8	44	40.4	20.2	40	3-1735482-1
30 u" Au - Sn <b>3</b>	100	84.20	SAME AS DIM D	79.20	94.0	20	85.8	120	116.4	58.2	200	3-1735482-0
	100	76.20		71.20	86.0	20	77.8	104	100.4	50.2	180	2-1735482-9
	100	68.20		63.20	73.8	20	69.8	88	84.4	42.2	160	2-1735482-8
	100	64.20		59.20	69.8	20	65.8	88	84.4	42.2	150	2-1735482-7
	100	60.20		55.20	65.8	20	61.8	88	84.4	42.2	140	2-1735482-6
	100	52.20		47.20	57.8	20	53.8	72	68.4	34.2	120	2-1735482-5
	100	44.20		39.20	49.8	20	45.8	72	68.4	34.2	100	2-1735482-4
	100	36.20		31.20	41.8	20	37.8	56	52.4	26.2	80	2-1735482-3
	100	28.20		23.20	33.8	20	29.8	44	40.4	20.2	60	2-1735482-2
	100	20.20		15.20	25.8	20	21.8	44	40.4	20.2	40	2-1735482-1
08 u" Au - Sn <b>2</b>	100	84.20	SAME AS DIM D	79.20	94.0	20	85.8	120	116.4	58.2	200	1-1735482-0
	100	76.20		71.20	86.0	20	77.8	104	100.4	50.2	180	1735482-9
	100	68.20		63.20	73.8	20	69.8	88	84.4	42.2	160	1735482-8
	100	64.20		59.20	69.8	20	65.8	88	84.4	42.2	150	1735482-7
	100	60.20		55.20	65.8	20	61.8	88	84.4	42.2	140	1735482-6
	100	52.20		47.20	57.8	20	53.8	72	68.4	34.2	120	1735482-5
	100	44.20		39.20	49.8	20	45.8	72	68.4	34.2	100	1735482-4
	100	36.20		31.20	41.8	20	37.8	56	52.4	26.2	80	1735482-3
	100	28.20		23.20	33.8	20	29.8	44	40.4	20.2	60	1735482-2
	100	20.20		15.20	25.8	20	21.8	44	40.4	20.2	40	1735482-1

THIS DRAWING IS A CONTROLLED DOCUMENT.		DWN RITA LIANG 01NOV17	<b>STE</b> TE Connectivity			
DIMENSIONS: mm		CHK SHOAL ALEX 06NOV17				
TOLERANCES UNLESS OTHERWISE SPECIFIED: 0 PLC ±0.30 1 PLC ±0.25 2 PLC ±0.20 3 PLC ±0.20 4 PLC ±0.20 ANGLES ±3°		APVD HOPE LU 06NOV17	NAME RECEPTACLE 17mm HEIGHT FH 0.8mm B-T-B CONNECTOR WITH STEEL COVER, ON EMBOSS TAPE			
MATERIAL <b>1</b>		PRODUCT SPEC 108-5390	SIZE <b>A3</b>	CAGE CODE 00779	DRAWING NO 1735482	RESTRICTED TO -
FINISH SEE P/N TABLE		APPLICATION SPEC 114-5254	SCALE 2:1		SHEET 3 OF 3	REV A3
		WEIGHT -	CUSTOMER DRAWING			



Компания «ЭлектроПласт» предлагает заключение долгосрочных отношений при поставках импортных электронных компонентов на взаимовыгодных условиях!

Наши преимущества:

- Оперативные поставки широкого спектра электронных компонентов отечественного и импортного производства напрямую от производителей и с крупнейших мировых складов;
- Поставка более 17-ти миллионов наименований электронных компонентов;
- Поставка сложных, дефицитных, либо снятых с производства позиций;
- Оперативные сроки поставки под заказ (от 5 рабочих дней);
- Экспресс доставка в любую точку России;
- Техническая поддержка проекта, помощь в подборе аналогов, поставка прототипов;
- Система менеджмента качества сертифицирована по Международному стандарту ISO 9001;
- Лицензия ФСБ на осуществление работ с использованием сведений, составляющих государственную тайну;
- Поставка специализированных компонентов (Xilinx, Altera, Analog Devices, Intersil, Interpoint, Microsemi, Aeroflex, Peregrine, Syfer, Eurofarad, Texas Instrument, Miteq, Cobham, E2V, MA-COM, Hittite, Mini-Circuits, General Dynamics и др.);

Помимо этого, одним из направлений компании «ЭлектроПласт» является направление «Источники питания». Мы предлагаем Вам помощь Конструкторского отдела:

- Подбор оптимального решения, техническое обоснование при выборе компонента;
- Подбор аналогов;
- Консультации по применению компонента;
- Поставка образцов и прототипов;
- Техническая поддержка проекта;
- Защита от снятия компонента с производства.



#### Как с нами связаться

**Телефон:** 8 (812) 309 58 32 (многоканальный)

**Факс:** 8 (812) 320-02-42

**Электронная почта:** [org@eplast1.ru](mailto:org@eplast1.ru)

**Адрес:** 198099, г. Санкт-Петербург, ул. Калинина, дом 2, корпус 4, литера А.