

## 3.3V Low Skew 1-to-2 Differential to LVPECL Fanout Buffer

**Features**

- Pin-to-pin compatible to ICS85311
- Maximum operation frequency: 800MHz
- 2 pair of differential LVPECL outputs
- CLK, nCLK pair accepts LVDS, LVPECL, LVHSTL, SSTL and HCSL input level
- Output Skew: 100ps (maximum)
- Part-to-part skew: 150ps (maximum)
- Propagation delay: 2ns (maximum)
- 3.3V power supply
- Operating Temperature: -40°C to 85°C
- Packaging (Pb-free & Green available):  
- 8-pin SOIC (W)

**Description**

The PI6C485311 is a high-performance low-skew LVPECL fanout buffer. PI6C485311 features two selectable differential inputs and translates to four LVPECL ultra-low jitter outputs. The inputs can also be configured to single-ended with external resistor bias circuit. The CLK input accepts LPECL or LVDS or LVHSTL or SSTL or HCSL signals, and PCLK input accepts LVPECL or SSTL or CML signals. PI6C485311 is ideal for differential to LVPECL translations and/or LVPECL clock distribution. Typical clock translation and distribution applications are data-communications and telecommunications.

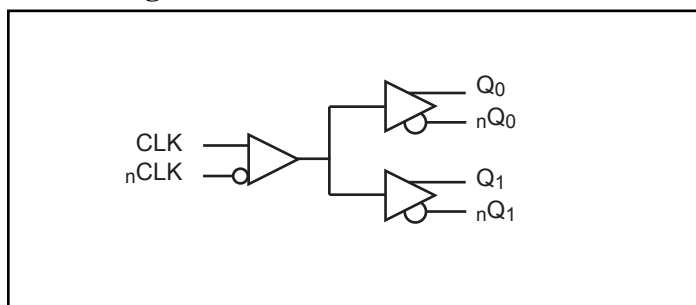
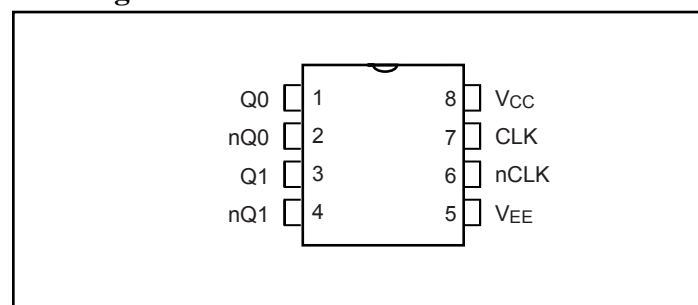
**Block Diagram**

**Pin Diagram**

### Pin Description

| Name   | Pin # | Type | Description                                       |
|--|-------|------|---|
| V <sub>EE</sub>                              | 5     | P    | Connect to Negative power supply                  |
| CLK  | 7     | I_PD | Non-inverting differential clock input            |
| <sub>n</sub> CLK                             | 6     | I_PU | Inverting differential clock input                |
| V <sub>CC</sub>                              | 8     | P    | Connect to 3.3V.                                  |
| Q <sub>1</sub> , <sub>n</sub> Q <sub>1</sub> | 3,4   | O    | Differential output pair, LVPECL interface level. |
| Q <sub>0</sub> , <sub>n</sub> Q <sub>0</sub> | 1,2   | O    | Differential output pair, LVPECL interface level. |

**Note:**

- I = Input, O = Output, P = Power supply connection, I\_PD = Input with pull down, I\_PU = Input with pull up

### Pin Characteristics

| Symbol                | Parameter                 | Conditions | Min. | Typ. | Max. | Units |
|-----------------------|---------------------------|------------|------|------|------|-------|
| C <sub>IN</sub>       | Input Capacitance         |            |      |      | 4    | pF    |
| R <sub>pullup</sub>   | Input Pullup Resistance   |            |      | 50   |      | KΩ    |
| R <sub>pulldown</sub> | Input Pulldown Resistance |            |      | 50   |      |       |

### Absolute Maximum Ratings<sup>(1)</sup>

| Symbol           | Parameter           | Conditions        | Min. | Typ. | Max.                  | Units |
|------------------|---------------------|-------------------|------|------|-----------------------|-------|
| V <sub>CC</sub>  | Supply voltage      | Referenced to GND |      |      | 4.6                   | V     |
| V <sub>IN</sub>  | Input voltage       | Referenced to GND | -0.5 |      | V <sub>CC</sub> +0.5V |       |
| V <sub>OUT</sub> | Output voltage      | Referenced to GND | -0.5 |      | V <sub>CC</sub> +0.5V |       |
| T <sub>STG</sub> | Storage temperature |                   | -65  |      | 150                   | °C    |

**Note:**

- Stresses above those listed under Absolute Maximum Ratings may cause permanent damage to the device. These ratings are stress specifications only and correct functional operation of the device at these or any other conditions above those listed in the operational sections of the specifications is not implied. Exposure to absolute maximum rating conditions for extended periods may affect product reliability.

### Operating Conditions

| Symbol          | Parameter            | Conditions | Min. | Typ. | Max. | Units |
|-----------------|----------------------|------------|------|------|------|-------|
| V <sub>CC</sub> | Power Supply Voltage |            | 3.0  | 3.3  | 3.6  | V     |
| T <sub>A</sub>  | Ambient Temperature  |            | -40  |      | 85   | °C    |
| I <sub>EE</sub> | Power Supply Current | 500 MHz    |      |      | 60   | mA    |

### Differential DC Input Characteristics (T<sub>A</sub> = -40°C to 85°C, V<sub>CC</sub> = 3.0V to 3.6V unless otherwise stated.)

| Symbol           | Parameter                                   | Conditions | Min.   | Typ. | Max.                   | Units |    |
|------------------|---|------------|--|------|------------------------|-------|----|
| I <sub>IH</sub>  | Input High Current                          | nCLK       | V <sub>IN</sub> = V <sub>CC</sub> = 3.6V     |      |                        | 5     | uA |
|                  |   | CLK        | V <sub>IN</sub> = V <sub>CC</sub> = 3.6V     |      |                        | 150   | uA |
| I <sub>IL</sub>  | Input Low Current                           | nCLK       | V <sub>CC</sub> = 3.6V, V <sub>IN</sub> = 0V | -150 |                        |       | uA |
|                  |   | CLK        | V <sub>CC</sub> = 3.6V, V <sub>IN</sub> = 0V | -5   |                        |       | uA |
| V <sub>PP</sub>  | Peak-to-peak Voltage                        |            | 0.15   |      | 1.3                    | V     |    |
| V <sub>CMR</sub> | Common Mode Input Voltage <sup>(1, 2)</sup> |            | V <sub>EE</sub> +0.5                         |      | V <sub>CC</sub> -0.85V | V     |    |

**Notes:**

1. For single ended applications, the maximum input voltage for CLK and nCLK is V<sub>CC</sub>+0.3V
2. Common mode voltage is defined as V<sub>IH</sub>.

### LVPECL DC Characteristics

( $T_A = -40^{\circ}\text{C}$  to  $85^{\circ}\text{C}$ ,  $V_{CC} = 3.0\text{V}$  to  $3.6\text{V}$ ,  $R_L = 50\Omega$  to  $V_{CC} - 2\text{V}$ , unless otherwise stated below.)

| Symbol      | Parameter  | Conditions    | Min.  | Typ. | Max.         | Units         |
|-------------|--|---------------|---|------|--------------|---------------|
| $I_{IH}$    | Input High Current                               | $\text{nCLK}$ | $V_{IN} = V_{CC} = 3.6\text{V}$               |      | 5            | $\mu\text{A}$ |
|             |  | CLK           | $V_{IN} = V_{CC} = 3.6\text{V}$               |      | 150          |               |
| $I_{IL}$    | Input Low Current                                | $\text{nCLK}$ | $V_{CC} = 3.6\text{V}$ , $V_{IN} = 0\text{V}$ | -150 |              | $\mu\text{A}$ |
|             |  | CLK           | $V_{CC} = 3.6\text{V}$ , $V_{IN} = 0\text{V}$ | -5   |              |               |
| $V_{PP}$    | Peak-to-peak Voltage                             |               | 0.3   |      | 1            | V             |
| $V_{CMR}$   | Common Mode Input Voltage; Note <sup>(1,2)</sup> |               | $V_{EE}+1.5$                                  |      | $V_{CC}$     |               |
| $V_{OH}$    | Output High Voltage                              |               | $V_{CC}-1.4$                                  |      | $V_{CC}-0.9$ |               |
| $V_{OL}$    | Output Low Voltage                               |               | $V_{CC}-2.0$                                  |      | $V_{CC}-1.6$ |               |
| $V_{SWING}$ | Peak-to-peak Output Voltage Swing                |               | 0.6   |      | 1.0          |               |

#### Notes:

- For single ended applications, the maximum input voltage for PCLK and  $\text{nPCLK}$  is  $V_{CC}+0.3\text{V}$ .
- Common mode voltage is defined as  $V_{IH}$ .

### AC Characteristics<sup>(1)</sup> ( $T_A = -40^{\circ}\text{C}$ to $85^{\circ}\text{C}$ , $V_{CC} = 3.0\text{V}$ to $3.6\text{V}$ , $R_L = 50\Omega$ to $V_{CC} - 2\text{V}$ , unless otherwise stated below.)

| Symbol       | Parameter                            | Conditions | Min. | Typ. | Max. | Units |
|--------------|--------------------------------------|------------|------|------|------|-------|
| $f_{max}$    | Output Frequency                     |            |      |      | 800  | MHz   |
| $t_{pd}$     | Propagation Delay <sup>(2)</sup>     |            | 1.0  |      | 2.0  | ns    |
| $T_{sk(o)}$  | Output-to-output Skew <sup>(3)</sup> |            |      |      | 100  | ps    |
| $T_{sk(pp)}$ | Part-to-part Skew <sup>(4)</sup>     |            |      |      | 150  |       |
| $t_r/t_f$    | Output Rise/Fall time                | 20% - 80%  | 75   |      | 300  |       |
| odc          | Output duty cycle                    |            | 40   |      | 60   | %     |

#### Notes:

- All parameters are measured at 500MHz unless noted otherwise
- Measured from the  $V_{CC}/2$  of the input to the differential output crossing point
- Defined as skew between outputs at the same supply voltage and with equal load condition. Measured at the outputs differential crossing point.
- Defined as skew between outputs on different parts operating at the same supply voltage and with equal load condition. Measured at the outputs differential crossing point.

### Applications Information

#### *Wiring the differential input to accept single ended levels*

Figure 1 shows how the differential input can be wired to accept single ended levels. The reference voltage  $V_{REF} = V_{DD}/2$  is generated by the bias resistors R1, R2 and C1. This bias circuit should be located as close as possible to the input pin. The ratio of R1 and R2 might need to be adjusted to position the  $V_{REF}$  in the center of the input voltage swing. For example, if the input clock swing is only 2.5V and  $V_{DD} = 3.3V$ ,  $V_{REF}$  should be 1.25V and  $R1/R2 = 0.609$ .

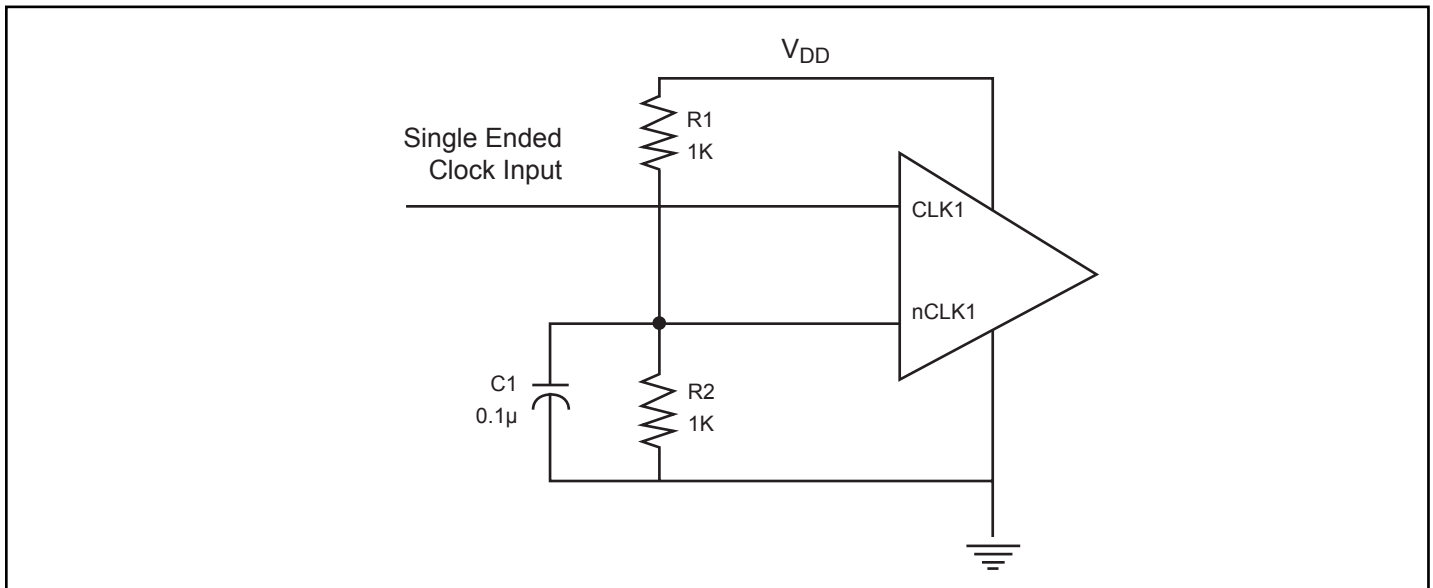

**Figure 2: Single-ended Signal Driving Differential Input**

**Packaging Mechanical: 8-Pin SOIC (W)**

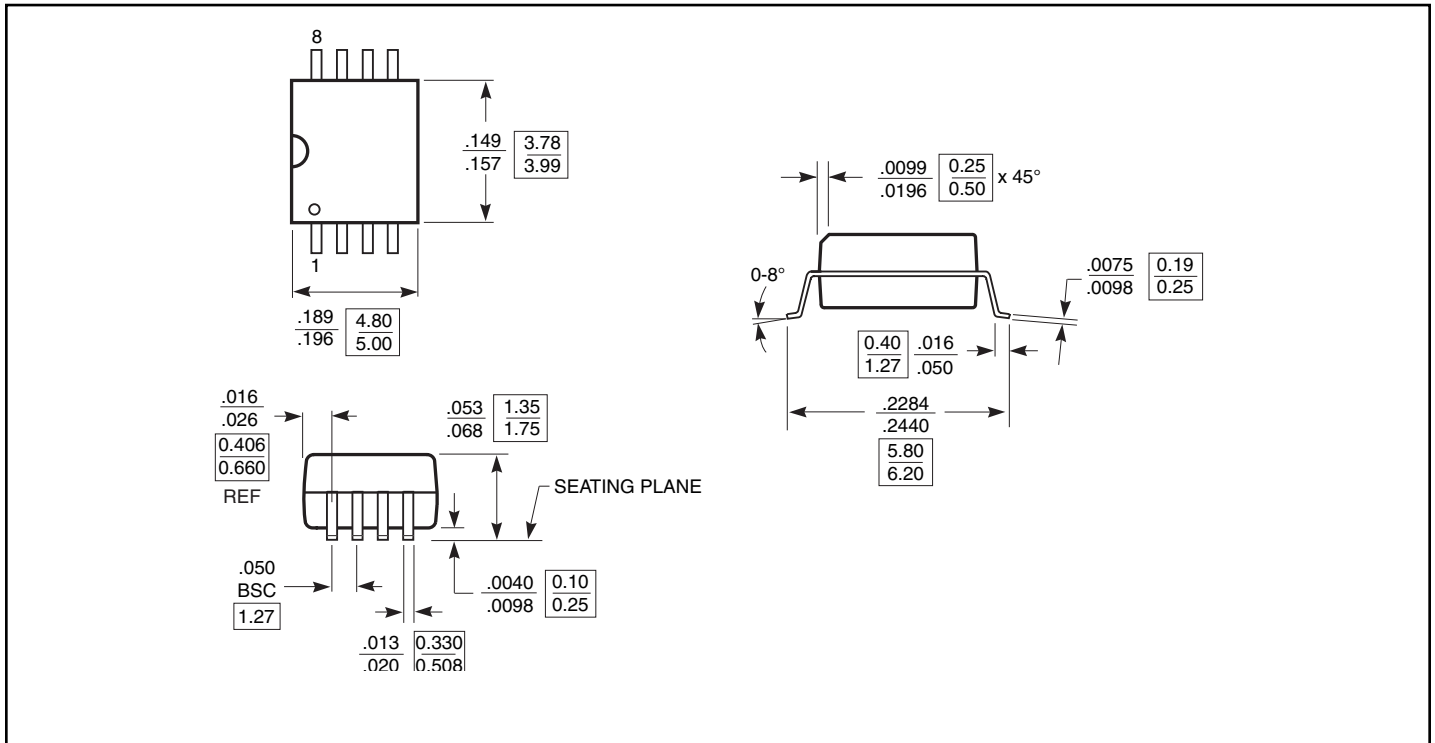

**Ordering Information(1,2)**

| Ordering Code | Package Code | Package Description         |
|---------------|--------------|-----------------------------|
| PI6C485311WE  | W            | Pb-free & Green, 8-pin SOIC |

**Notes:**

1. Thermal characteristics can be found on the company web site at [www.pericom.com/packaging/](http://www.pericom.com/packaging/)
2. E = Pb-free and Green



Компания «ЭлектроПласт» предлагает заключение долгосрочных отношений при поставках импортных электронных компонентов на взаимовыгодных условиях!

Наши преимущества:

- Оперативные поставки широкого спектра электронных компонентов отечественного и импортного производства напрямую от производителей и с крупнейших мировых складов;
- Поставка более 17-ти миллионов наименований электронных компонентов;
- Поставка сложных, дефицитных, либо снятых с производства позиций;
- Оперативные сроки поставки под заказ (от 5 рабочих дней);
- Экспресс доставка в любую точку России;
- Техническая поддержка проекта, помощь в подборе аналогов, поставка прототипов;
- Система менеджмента качества сертифицирована по Международному стандарту ISO 9001;
- Лицензия ФСБ на осуществление работ с использованием сведений, составляющих государственную тайну;
- Поставка специализированных компонентов (Xilinx, Altera, Analog Devices, Intersil, Interpoint, Microsemi, Aeroflex, Peregrine, Syfer, Eurofarad, Texas Instrument, Miteq, Cobham, E2V, MA-COM, Hittite, Mini-Circuits, General Dynamics и др.);

Помимо этого, одним из направлений компании «ЭлектроПласт» является направление «Источники питания». Мы предлагаем Вам помощь Конструкторского отдела:

- Подбор оптимального решения, техническое обоснование при выборе компонента;
- Подбор аналогов;
- Консультации по применению компонента;
- Поставка образцов и прототипов;
- Техническая поддержка проекта;
- Защита от снятия компонента с производства.



#### Как с нами связаться

**Телефон:** 8 (812) 309 58 32 (многоканальный)

**Факс:** 8 (812) 320-02-42

**Электронная почта:** [org@eplast1.ru](mailto:org@eplast1.ru)

**Адрес:** 198099, г. Санкт-Петербург, ул. Калинина, дом 2, корпус 4, литера А.