

# Lithium-Ion Battery Pulse Charger with Overcurrent Protection

## FEATURES

- **Very Low Power Dissipation: 350mW at 1A**
- **Complete Standalone Pulse Charger for 1-Cell Lithium-Ion Batteries**
- **Requires No Microcontroller, MOSFET or Blocking Diode**
- **Sense Resistor Limits Maximum Current for Safety**
- **Programmable Charge Termination Timer for Maximum Capacity Charging**
- **±1% Float Voltage Accuracy**
- **Near End-of-Charge (C/10) Detection Output**
- **AC Wall Adapter Present Output**
- **Low Battery Drain when Input Supply Is Removed**
- **Automatic Trickle Charge for Low Battery**
- **Automatic Battery Refresh**
- **Thermal Shutdown Protection**
- **Tiny Thermally Enhanced MSOP Package**

## APPLICATIONS

- Handheld Computers
- Cellular Telephones
- Cradle Chargers

## DESCRIPTION

The LTC<sup>®</sup>4052 is a complete standalone pulse charger with integrated MOSFET for 1-cell lithium-ion batteries.

An external sense resistor provides overcurrent limiting as a safety precaution against a user connecting a wall adapter with the incorrect or no current limit. The internal MOSFET prevents reverse battery current from flowing if the input voltage is shorted to ground, eliminating the need for a blocking diode.

As the battery accepts charge and approaches the programmed float voltage, the internal MOSFET begins switching off and on with the duty cycle gradually decreasing as the battery approaches a fully charged condition. A programmable timer terminates the charge cycle. The near end-of-charge C/10 condition is indicated at the CHRG pin when the average charge current falls to one-tenth of the wall adapter current. Removing the input voltage puts the LTC4052 into a sleep mode, dropping the battery current drain to less than 1μA.

The LTC4052 is available in a tiny 8-pin thermally enhanced MSOP package.

 LTC and LT are registered trademarks of Linear Technology Corporation.

## TYPICAL APPLICATION

Single Cell 4.2V, 1A, Standalone Li-Ion Battery Charger

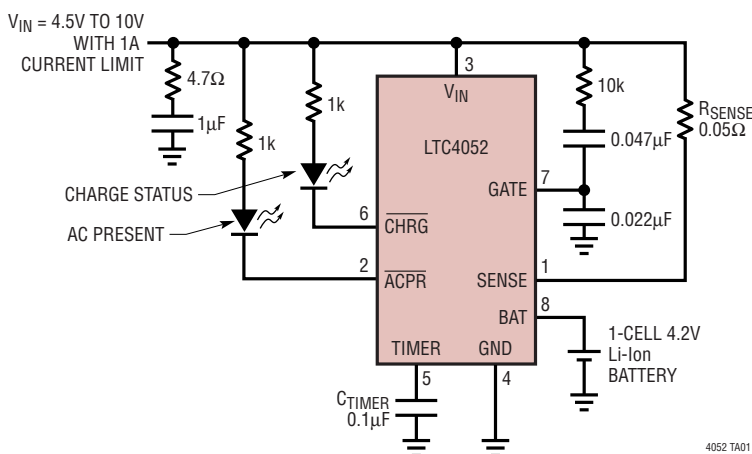

4052 TA01

LTC4052 Charge Profile

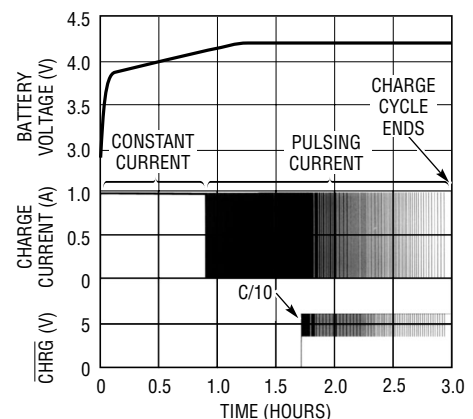

4052 • TA01b

405242f

## ABSOLUTE MAXIMUM RATINGS

(Note 1)

Input Supply Voltage ( $V_{IN}$ ) .....	12V
BAT Voltage .....	-0.3V to 12V
GATE (Note 2) .....	-0.3V to 8V
SENSE, TIMER .....	-0.3V to $V_{IN} + 0.3V$
CHRG, ACPR .....	-0.3V to 12V
SENSE, BAT Peak Current .....	1.5A
Operating Temperature Range (Note 3) ..	-40°C to 85°C
Junction Temperature (Note 4) .....	125°C
Storage Temperature Range .....	-65°C to 150°C
Lead Temperature (Soldering, 10 sec) .....	300°C

## PACKAGE/ORDER INFORMATION

<p>MSE EXPOSED PAD PACKAGE 8-LEAD PLASTIC MSOP</p> <p><math>T_{JMAX} = 125^{\circ}C</math>, <math>\theta_{JA} = 35^{\circ}C/W</math> EXPOSED PAD IS GROUND. (MUST BE SOLDERED TO PCB).</p>	ORDER PART NUMBER
	LTC4052EMS8E-4.2
	MS8 PART MARKING
	LTTY

Consult LTC Marketing for parts specified with wider operating temperature ranges.

## DC ELECTRICAL CHARACTERISTICS

The ● denotes the specifications which apply over the full operating temperature range, otherwise specifications are at  $T_A = 25^{\circ}C$ .  $V_{IN} = 6V$  unless otherwise noted.

SYMBOL	PARAMETER	CONDITIONS	MIN	TYP	MAX	UNITS	
$V_{IN}$	Input Supply Voltage	Wall Adapter Open Circuit Voltage	● 4.5		10	V	
$I_{IN}$	Input Quiescent Supply Current	Full Charge Mode	●	0.7	1.4	mA	
$V_{BAT}$	Battery Float Voltage	$0^{\circ}C \leq T_A \leq 85^{\circ}C$	● 4.158	4.200	4.242	V	
			● 4.137	4.200	4.242	V	
$V_{RECHRG}$	Recharge Battery Voltage Threshold	Battery Voltage Falling $0^{\circ}C \leq T_A \leq 85^{\circ}C$	● 3.990	4.050	4.110	V	
			● 3.969	4.050	4.110	V	
$V_{MARGIN}$	$V_{BAT} - V_{RECHRG}$ Margin		● 75	150	225	mV	
$V_{IMAX}$	Overcurrent Trip Sense Voltage		● 90	105	120	mV	
$I_{TRICKLE}$	Trickle Charge Current	$V_{BAT} = 2V$	● 14	24	34	mA	
$V_{TRICKLE}$	Trickle Charge Threshold Voltage	$V_{BAT}$ Rising	● 2.35	2.45	2.55	V	
$R_{DS(ON)}$	Internal Switch On-Resistance	$V_{BAT} = 2.6V$ $V_{BAT} = 4V$		0.45	0.7	$\Omega$	
				0.35	0.5	$\Omega$	
$V_{GATE}$	GATE Pin Voltage	$V_{BAT} = 2.6V$ $V_{BAT} = 4V$		6.5		V	
				10.5		V	
$T_{TIMER}$	TIMER Period Accuracy	$C_{TIMER} = 0.1\mu F$ , Full Charge Mode			$\pm 10$	%	
$I_{LEAK}$	Battery Leakage Current Through Charger	$V_{BAT} = 4V$ , $V_{IN} = 0V$	●		1	$\mu A$	
$V_{SLEEP}$	Sleep Threshold Voltage	$(V_{IN} - V_{BAT})$ Low to High $(V_{IN} - V_{BAT})$ High to Low		20	45	70	mV
				0	15	mV	
$V_{ACPR}$	ACPR Pin Output Low Voltage	$I_{ACPR} = 3mA$	●	0.5	0.8	V	
$I_{LEAKACPR}$	ACPR Pin Leakage Current	$V_{IN} = 0$ , $V_{ACPR} = 6V$	●		1	$\mu A$	
$V_{CHRG}$	CHRG Pin Output Low Voltage	$I_{CHRG} = 3mA$ , Charging, C/10 Not Reached	●	0.5	0.8	V	
$I_{LEAKCHRG}$	CHRG Pin Leakage Current	$V_{IN} = 0$ , $V_{CHRG} = 6V$	●		1	$\mu A$	
$I_{CHRG}$	CHRG Pin Weak Pull-Down Current	$V_{CHRG} = 1V$ , Charging, C/10 Reached		20	40	70	$\mu A$

## ELECTRICAL CHARACTERISTICS

**Note 1:** Absolute Maximum Ratings are those values beyond which the life of a device may be impaired.

**Note 2:** Absolute Maximum Rating for GATE pin applies only to externally applied voltage. During normal operation the LTC4052-4.2's internal charge pump can generate GATE pin voltage exceeding absolute maximum but it is internally current limited.

**Note 3:** The LTC4052EMS8E-4.2 is guaranteed to meet performance specifications from 0°C to 70°C. Specifications over the -40°C to 85°C operating temperature range are assured by design, characterization and correlation with statistical process controls.

**Note 4:** Junction temperature  $T_J$  is calculated from the ambient temperature  $T_A$  and power dissipation  $P_D$  according to the following formula:  $T_J = T_A + (P_D \cdot \theta_{JA})^{\circ}\text{C}/\text{W}$

**Note 5:** This IC includes overtemperature protection that is intended to protect the device during momentary overload conditions. Junction temperature will exceed 125°C when overtemperature protection is active. Continuous operation above the specified maximum operating junction temperature may impair device reliability.

## TYPICAL PERFORMANCE CHARACTERISTICS

Trickle Charge Threshold Voltage vs Temperature

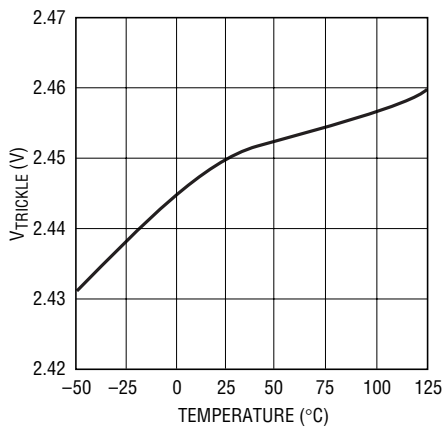

4052 G01

Trickle Charge Current vs Temperature

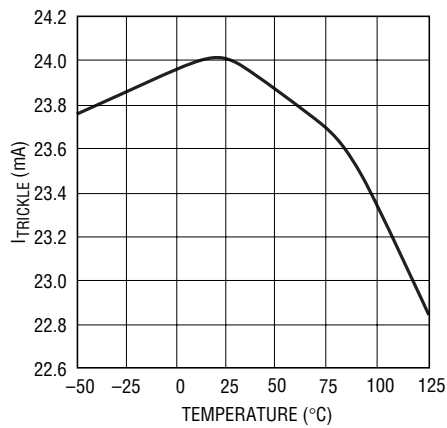

4052 G02

Trickle Charge Current vs Input Supply Voltage

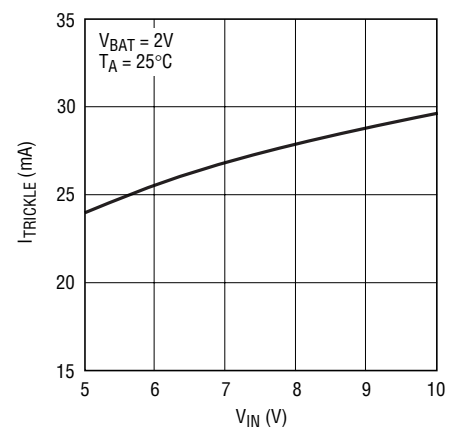

4052 G03

Normalized Timer Duration vs Temperature

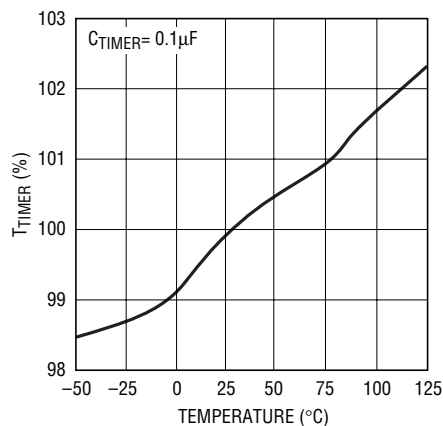

4052 G04

Battery Float Voltage vs Temperature

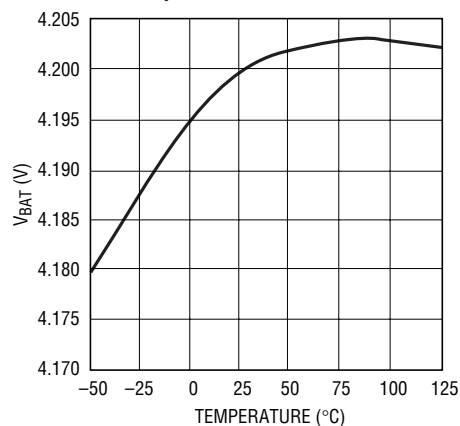

4052 G05

CHRG Pin C/10 Pulldown Current vs Temperature

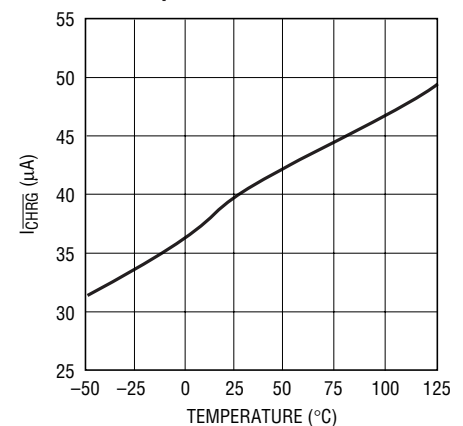

4052 G06

## TYPICAL PERFORMANCE CHARACTERISTICS

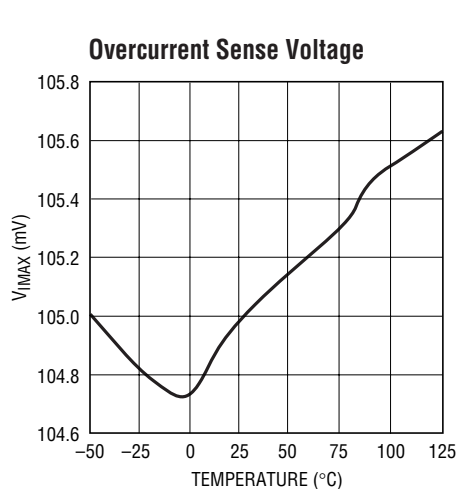

4053 G07

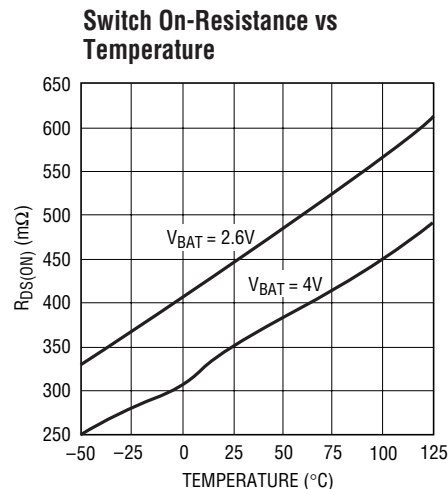

4053 G08

## PIN FUNCTIONS

**SENSE (Pin 1):** Overcurrent Sense Input. A sense resistor ( $R_{SENSE}$ ) should be connected from  $V_{IN}$  to the SENSE pin to program the current limit level. When overcurrent limit is tripped, the pass transistor immediately turns off and turns back on after a 640ms time-out period ( $C_{TIMER} = 0.1\mu F$ ). The on-off cycle will continue as long as the overcurrent condition persists or until the timer runs out. If overcurrent protection is not needed, short SENSE to  $V_{IN}$ .

**ACPR (Pin 2):** AC Wall Adapter Present Open-Drain Output. When the input voltage (wall adapter) is applied to the LTC4052, this pin is pulled to ground by an internal N-channel MOSFET capable of driving an LED.

**$V_{IN}$  (Pin 3):** Positive Input Supply Voltage ( $4.5V \leq V_{IN} \leq 10V$ ). Bypass this pin with a  $1\mu F$  capacitor in series with a  $4.7\Omega$  resistor.

**GND (Pin 4):** Electrical Ground Connection and provides a thermal path from the IC to the PC board copper. The exposed backside of the package is also ground and must be soldered to the PC board for maximum power dissipation.

**TIMER (Pin 5):** Timer Set Pin. The timer period is programmed by a capacitor ( $C_{TIMER}$ ) to ground. The timer period is:  $t_{TIMER} = (C_{TIMER} \cdot 3Hr)/(0.1\mu F)$ . The minimum

ON time, minimum OFF time and the overcurrent time-out period all scale with  $t_{TIMER}$ .

**CHRG (Pin 6):** Charge Status Open-Drain Output. When a depleted battery is being charged, the CHRG pin is pulled to ground by an internal N-channel MOSFET capable of driving an LED. Once the duty cycle at the GATE pin drops below 10%, the N-MOSFET turns off and a weak  $40\mu A$  current source to ground turns on to indicate a near end-of-charge C/10 condition. When a time-out occurs or the input supply is removed, the CHRG pin becomes high impedance.

**GATE (Pin 7):** Gate Drive Output Pin for Internal and External Pass Transistors. An external N-MOSFET transistor can be connected in parallel with the internal transistor to reduce the on-resistance for higher charge current. In this case, an external blocking diode on  $V_{IN}$  is required to prevent damage to the battery if  $V_{IN}$  is shorted to ground. A  $10\mu A$  current source pulls this pin up to the charge pump voltage when turned on and a  $40\mu A$  current source pulls it down to ground to turn it off. If an overcurrent condition is detected, the GATE pin is immediately pulled to ground. The voltage at this pin is internally clamped to 12V above the GND pin.



## OPERATION

The LTC4052 is a complete lithium-ion battery pulse charger with an internal  $0.35\Omega$  N-MOSFET switch driven by an internal charge pump. **The charge current is set by the current limit of the input supply (wall adapter).** An external  $R_{SENSE}$  sets the maximum allowable charge overcurrent and prevents a wall adapter with a high current limit from damaging the battery. If the current limit of the input supply is above  $I_{MAX}$ , the charger will immediately turn off the N-MOSFET switch and will retry after 640ms, thus reducing the average charge current to approximately 1% of the overcurrent value ( $C_{TIMER} = 0.1\mu F$ ). If the battery is disconnected while in full charge mode, the charge pump turns off when the voltage at the BAT pin rises above 4.7V and turns back on when the voltage drops below the float voltage.

A charge cycle begins when the voltage at the  $V_{IN}$  pin rises above the BAT pin by 45mV. The charger will go into trickle charge mode if the battery voltage is below 2.45V. The trickle charge current is preset to 24mA and is provided by an internal current source. In trickle mode, both the pass transistor and charge pump are off.

When the cell voltage exceeds 2.45V, the charger goes into full charge mode. In this mode, the charge pump turns on and ramps up the gate voltage of the pass transistor turning it on. The current limited voltage at the  $V_{IN}$  pin will ramp down to  $V_{BAT}$  plus the voltage drop across the pass transistor and  $R_{SENSE}$ , thus reducing the power dissipa-

tion in the pass transistor. **The charge current is determined by the current limit of the input supply.**

When the battery voltage reaches the final float voltage, the pass transistor turns off for 100ms (minimum off-time). It remains off as long as the battery voltage stays above the float voltage after the 100ms off-time. After the minimum off-time, if the battery voltage drops below the float voltage, the pass transistor turns back on for at least 400ms (minimum on-time). As the battery approaches full charge, the off-time will get longer and the on-time will stay at 400ms. When the N-MOSFET switch is on, the voltage at the BAT pin will be slightly higher than the final float voltage due to the ESR associated with the battery pack. This voltage level should not be high enough to turn on the overvoltage protection circuitry often located in the battery pack. When the duty cycle at the GATE pin drops below 10%, a comparator turns off the N-FET at the  $\overline{CHRG}$  pin and connects a weak current source ( $40\mu A$ ) to ground to indicate a near end-of-charge C/10 condition. The pulse charging will continue until the timer stops.

An external capacitor at the TIMER pin sets the total charge time, the minimum on- and off-time and the overcurrent retry period. After a time-out has occurred, the charge cycle terminates and the  $\overline{CHRG}$  pin is forced high impedance. After the charging stops, if the battery voltage drops below 4.05V due to external loading or internal battery leakage current, a new charge cycle will automatically resume.

## APPLICATIONS INFORMATION

### Input Voltage (Wall Adapter)

The input voltage to the LTC4052 must have some method of current limit capability. The current limit level of the input power source must be lower than the overcurrent limit ( $I_{MAX}$ ) set by the sense resistor  $I_{MAX} = 105\text{mV}/(R_{SENSE} + 10\text{m}\Omega)$ . The  $10\text{m}\Omega$  represents bond wire resistance internal to the IC. If a wall adapter without current limit is used, or the current limit level is above  $I_{MAX}$ , the charger will turn on briefly and then immediately turn off when the overcurrent condition is detected. This cycle will be resumed every  $640\text{ms}$  ( $C_{TIMER} = 0.1\mu\text{F}$ ) until the total charge time has run out. If overcurrent protection is not needed, short the SENSE pin to  $V_{IN}$ . The overcurrent limit selected should be approximately twice the charge current (input supply current limit).

### Trickle Charge and Defective Battery Detection

At the beginning of the charge cycle, if the cell voltage is low (less than  $2.45\text{V}$ ) the charger goes into a  $24\text{mA}$  trickle charge mode. If the low cell voltage persists for one quarter of the total charge time, the battery is considered defective and the charge cycle is terminated. The CHRG pin output is then forced to a high impedance state.

### Battery Charge Current

The battery charge current is determined by the current limit of the input supply (wall adapter). However, this current must not exceed the maximum charge overcurrent,  $I_{MAX}$ . If an overcurrent condition is detected, the internal switch immediately turns off, the GATE pin is pulled to ground and the charge pump turns off. The charging will resume after a  $640\text{ms}$  time off ( $C_{TIMER} = 0.1\mu\text{F}$ ).

### Programming the Timer

The programmable timer is used to terminate the charge cycle and set the minimum ON/OFF time and the overcurrent time-off period. The length of the timer is programmed by an external capacitor from the TIMER pin to ground. The total charge time is:

$$\text{Time (Hours)} = (3 \text{ Hours})(C_{TIMER}/0.1\mu\text{F}) \text{ or}$$

$$C_{TIMER} = 0.1\mu\text{F} \cdot \text{Time (Hours)}/3 \text{ (Hours)}$$

The timer starts when an input voltage which is at least  $40\text{mV}$  greater than  $V_{BAT}$  is applied. After a time-out has occurred, the charge cycle stops and the CHRG pin becomes high impedance.

### CHRG Status Output Pin

This open-drain output can report three different charger conditions:

Charger Status	CHRG Pin Behavior
Not Charging	High Impedance
Charging	Strong Pulldown
Charging, C/10 Reached	Weak $40\mu\text{A}$ Pulldown

Using a simple two-resistor network a microprocessor can distinguish all three states. See Figure 1.

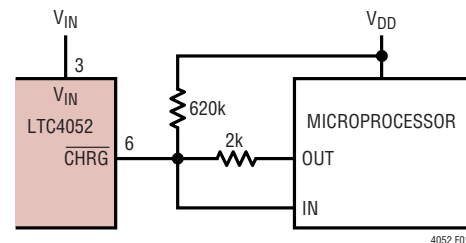

Figure 1. Interfacing with Microprocessor

When the LTC4052 is charging a battery, an internal N-MOSFET pulls the CHRG pin to ground. When C/10 is reached, the strong NMOS pulldown is replaced by a weak  $40\mu\text{A}$  current source pulldown. When the LTC4052 is not charging a battery, the CHRG pin is high impedance.

Using the network in Figure 1, the microprocessor can determine charger state using the following procedure:

1. Force the digital output pin, OUT, high and read the logic value at the digital input, IN. If IN reads low, a charger cycle is in progress.
2. If the IN pin is high, force the OUT pin to be high impedance, then read the logic level at the IN pin again. If IN is low, the charge cycle is still in progress, the timer is still running, but the charge current has dropped below 10% of the programmed value indicating that the charge cycle is nearly complete.
3. If the logic level at the IN pin is high, the charge cycle has ended.



## APPLICATIONS INFORMATION

### C/10 Detection (Near End-of-Charge)

The LTC4052 includes a comparator to monitor the duty cycle at the GATE pin to detect when the battery is nearing full charge. When the duty cycle falls below 10%, the comparator trips and turns off the N-MOSFET at the CHRG pin and switches in a weak (40 $\mu$ A) current source to ground. The 40 $\mu$ A turns off when the timer terminates the charge cycle. C/10 detection is disabled in trickle charge mode.

### Internal Pass Transistor

An N-channel MOSFET (0.35 $\Omega$ ) pass transistor is included in the LTC4052. The gate of the MOSFET is controlled by an internal charge pump. The body is connected to ground instead of source terminal. There is no body diode from the BAT pin back to the  $V_{IN}$  pin; therefore, no blocking diode is required in series with the battery or the input supply. This will not only reduce cost but also reduce the heat generated while in full charge mode. An internal thermal shutdown circuit turns the pass transistor off if the die temperature exceeds approximately 140 $^{\circ}$ C with 5 $^{\circ}$ C of thermal hysteresis.

### Gate Drive

The MOSFET gate drive consists of a regulated 10 $\mu$ A current source charge pump. A series RC network is required from the GATE pin to the  $V_{IN}$  pin. When the MOSFET is turned on, the voltage at the  $V_{IN}$  pin will begin slewing down to a voltage equal to  $V_{BAT}$  plus the voltage drop across the pass transistor and  $R_{SENSE}$ . The slew rate is equal to 10 $\mu$ A/C. By ramping the  $V_{IN}$  pin down slowly, the inrush current is reduced. The resistor in series with the capacitor is required to limit the transient current when the input supply is first applied.

When the charge pump is turned off, a 50 $\mu$ A current source to ground will start pulling the GATE voltage down. Once the pass transistor is off, the voltage at the  $V_{IN}$  pin will begin slewing up with the rate equal to 50 $\mu$ A/C. With this external capacitor, the voltage at the  $V_{IN}$  pin is ramping in a controlled manner (Figure 2).

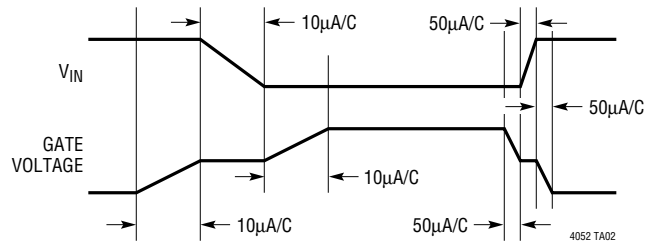

Figure 2. Slew Rate at GATE and  $V_{IN}$  Pins with the RC Network from GATE to  $V_{IN}$

For higher current applications an external power N-channel MOSFET can be connected in parallel with the internal pass transistor. Because the charge pump output is clamped to 12V above GND, the external MOSFET gate to source voltage rating should be 16V or more.

### Thermal Considerations

The power handling capability is limited by the maximum rated junction temperature (125 $^{\circ}$ C) and the amount of PC board copper used as a heat sink. The power dissipated by the IC consists of two components:

1. Input supply quiescent current multiplied by the input voltage
2. The voltage drop across the switch (SENSE pin to BAT pin) multiplied by the charge current

The LTC4052 has internal thermal shutdown designed to protect the IC from overtemperature conditions. For continuous charging in the fast charge mode, the maximum junction temperature must not be exceeded. It is important to give careful consideration to all sources of thermal resistance from junction to ambient. Additional heat sources mounted nearby must also be considered.

Surface mount packages rely primarily on the PC board copper to dissipate the heat generated by the package to the surrounding air. Since the PC board copper is the heat sink, generous amounts of copper surrounding the package are recommended to increase the effectiveness of the heat sink.



## APPLICATIONS INFORMATION

In addition, feedthrough vias or plated through holes (located directly beneath the package and elsewhere) connecting internal copper and backside copper layers help transfer and spread the heat generated by the package.

### Calculating Junction Temperature

Example: Find the maximum junction temperature for a battery voltage of 4V ( $V_{IN}$  will collapse to approximately  $V_{BAT}$  in the full charge mode), charge current of 1A and a maximum ambient temperature of 75°C.

The power dissipated by the IC is:

$$\begin{aligned} P &= (I_{BAT} \cdot I_{BAT} \cdot R_{DS(ON)}) + (V_{IN} \cdot I_{IN}) \\ &= (1A \cdot 1A \cdot 0.35\Omega) + (4V \cdot 0.7mA) \\ &= 0.35 + 0.003 \\ &= 0.353W \end{aligned}$$

The LTC4052 is available in an enhanced 8-pin MSOP package which features an exposed copper pad on the bottom of the package allowing it to be soldered directly to the PC board copper for maximum heat transfer. This greatly reduces the thermal resistance and increases the power handling capability when compared to a standard MSOP package. The junction to ambient thermal resistance of this package when the backside of the package is

soldered to the PC board is approximately 35°C/W depending on the copper area. The junction temperature rise above ambient will be approximately:

$$(0.353W)(35^\circ\text{C/W}) = 12.36^\circ\text{C}$$

The maximum junction temperature will be equal to the maximum junction temperature rise above ambient plus the maximum ambient temperature or:

$$T_{JMAX} = 85^\circ\text{C} + 12.36^\circ\text{C} = 97.36^\circ\text{C}$$

### ACPR Output Pin

When the input voltage is 45mV higher than the voltage at the BAT pin, the  $\overline{\text{ACPR}}$  pin is pulled to ground to indicate that the input supply (wall adapter) is applied. After the input supply is removed, this pin will become high impedance. An internal 100ms filter prevents the LTC4052 from turning off if the voltage at the  $V_{IN}$  pin rings and gets too close to  $V_{BAT}$  due to parasitic inductance.

### Stop Charging

The charger is off when the voltage at the  $V_{IN}$  pin is less than 45mV above  $V_{BAT}$  (sleep mode). The charge pump and the internal pass transistor are turned off, and the internal resistor divider is disconnected to reduce the current drain on the battery in the sleep mode.

**TYPICAL APPLICATION**

**External N-MOSFET for Higher Charge Current**

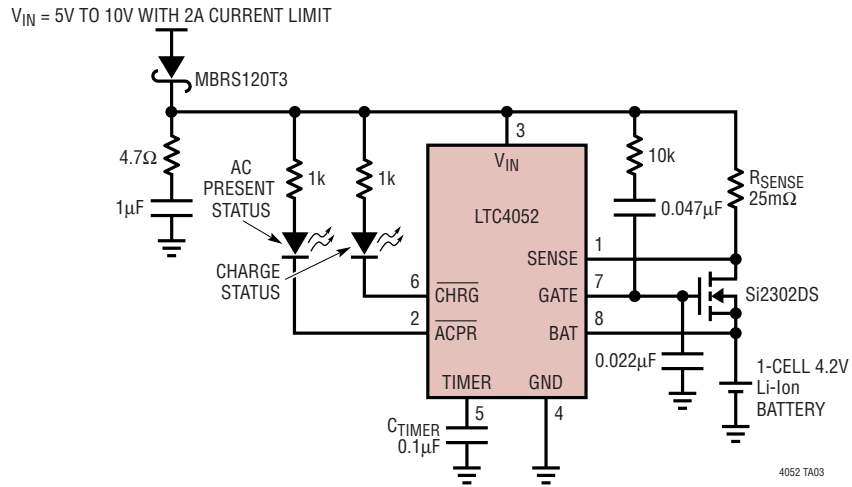

# PACKAGE DESCRIPTION

**MS8E Package**  
**8-Lead Plastic MSOP**  
 (Reference LTC DWG # 05-08-1662)

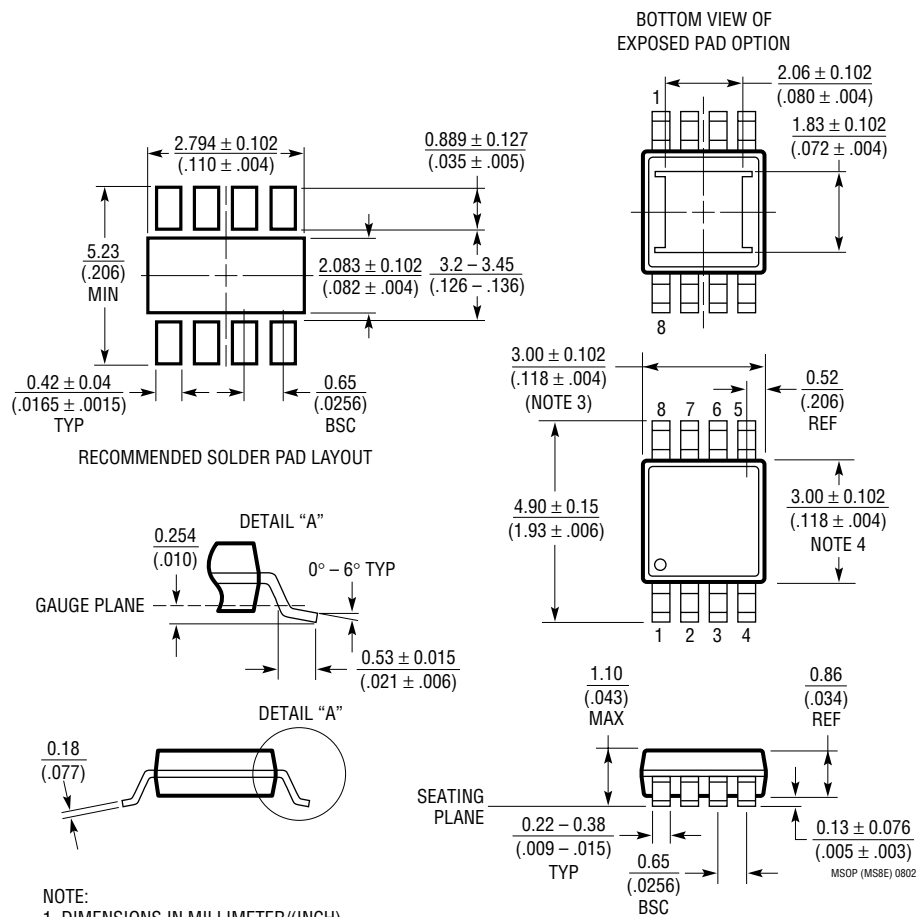

## NOTE:

1. DIMENSIONS IN MILLIMETER/(INCH)
2. DRAWING NOT TO SCALE
3. DIMENSION DOES NOT INCLUDE MOLD FLASH, PROTRUSIONS OR GATE BURRS.  
MOLD FLASH, PROTRUSIONS OR GATE BURRS SHALL NOT EXCEED 0.152mm (.006") PER SIDE
4. DIMENSION DOES NOT INCLUDE INTERLEAD FLASH OR PROTRUSIONS.  
INTERLEAD FLASH OR PROTRUSIONS SHALL NOT EXCEED 0.152mm (.006") PER SIDE
5. LEAD COPLANARITY (BOTTOM OF LEADS AFTER FORMING) SHALL BE 0.102mm (.004") MAX

## TYPICAL APPLICATION

### Minimum Component Count 4.2V Li-Ion Battery Charger

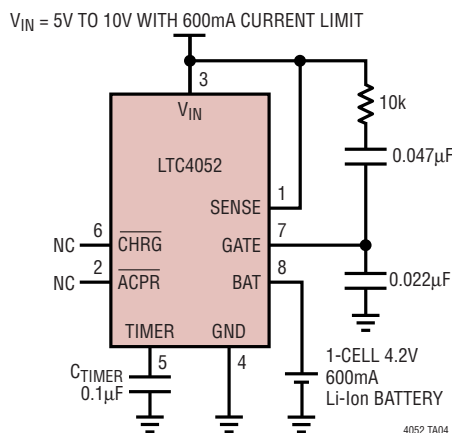

## RELATED PARTS

PART NUMBER	DESCRIPTION	COMMENTS
LT1510-5	500kHz CC/CV Battery Charger	Most Compact, Up to 1.5A, Charges NiCd, NiMH, Li-Ion Cells
LTC1730	Li-Ion Battery Pulse Charger with Thermistor Interface	Battery Temperature Sensing, FAULT Output, SSOP-16 Package
LTC1731	Li-Ion Battery Charger Controller	CC/CV Charges Li-Ion Cells, 8-Lead MSOP
LTC1732	Li-Ion Battery Charger Controller	CC/CV Charges Li-Ion Cells, Automatic Battery Detection, 10-Lead MSOP
LTC1733	Li-Ion Battery Charger with Thermal Regulation	Standalone Charger, Constant-Current/Constant-Voltage/ Constant-Temperature, Integrated MOSFET, No External Sense Resistor or Blocking Diodes
LTC1734/ LTC1734L	ThinSOT™ Li-Ion Battery Charger	Only Two External Components, 50mA to 700mA $I_{CHARGE}$ , No Reverse Current Diode Required, No Sense Resistor Required
LTC4050	Li-Ion Battery Charger Controller with Thermistor Interface	Drives External MOSFET, 10-Lead MSOP
LTC4053	USB Compatible Li-Ion Battery Charger	Fully Integrated, Standalone USB Battery Charger, Thermal Regulation Prevents Overheating, Charges from USB Port and/or Wall Adapter Input
LTC4054	Standalone, Monolithic Li-Ion Battery Charger in ThinSOT	C/10 Charge Termination, up to 800mA Charge Current

ThinSOT is a trademark of Linear Technology Corporation



Компания «ЭлектроПласт» предлагает заключение долгосрочных отношений при поставках импортных электронных компонентов на взаимовыгодных условиях!

Наши преимущества:

- Оперативные поставки широкого спектра электронных компонентов отечественного и импортного производства напрямую от производителей и с крупнейших мировых складов;
- Поставка более 17-ти миллионов наименований электронных компонентов;
- Поставка сложных, дефицитных, либо снятых с производства позиций;
- Оперативные сроки поставки под заказ (от 5 рабочих дней);
- Экспресс доставка в любую точку России;
- Техническая поддержка проекта, помощь в подборе аналогов, поставка прототипов;
- Система менеджмента качества сертифицирована по Международному стандарту ISO 9001;
- Лицензия ФСБ на осуществление работ с использованием сведений, составляющих государственную тайну;
- Поставка специализированных компонентов (Xilinx, Altera, Analog Devices, Intersil, Interpoint, Microsemi, Aeroflex, Peregrine, Syfer, Eurofarad, Texas Instrument, Miteq, Cobham, E2V, MA-COM, Hittite, Mini-Circuits, General Dynamics и др.);

Помимо этого, одним из направлений компании «ЭлектроПласт» является направление «Источники питания». Мы предлагаем Вам помощь Конструкторского отдела:

- Подбор оптимального решения, техническое обоснование при выборе компонента;
- Подбор аналогов;
- Консультации по применению компонента;
- Поставка образцов и прототипов;
- Техническая поддержка проекта;
- Защита от снятия компонента с производства.



#### Как с нами связаться

**Телефон:** 8 (812) 309 58 32 (многоканальный)

**Факс:** 8 (812) 320-02-42

**Электронная почта:** [org@eplast1.ru](mailto:org@eplast1.ru)

**Адрес:** 198099, г. Санкт-Петербург, ул. Калинина, дом 2, корпус 4, литера А.