



TDA8023

Low power IC card interface

Rev. 2.0 — 24 June 2016

Product data sheet

1. General description

The TDA8023 is a complete cost-efficient, low-power analog interface for synchronous or asynchronous smart cards. It can be placed between the card and the microcontroller with very few external components to perform all supply, protection and control functions.

2. Features and benefits

- I²C-bus controlled IC card interface in TSSOP28
- Supply voltage from 2.7 V to 6.5 V
- Independant supply voltage $V_{DD(INTF)}$ for interface signals with the microcontroller
- Shutdown input for very low power consumption when the part is not used
- Power reduction modes when the card is active
- DC-to-DC converter for V_{CC} generation (capacitive doubler, tripler, or inductive, or follower automatically selected according to supply voltage and card voltage)
- 1 specific protected half duplex bidirectional buffered I/O line, with current limitation at ± 15 mA, maximum frequency 1 MHz
- 2 auxiliary card I/O lines controlled by I²C-bus (C4 and C8)
- V_{CC} regulation: 5 V, 3 V or 1.8 V $\pm 8\%$, $I_{CC} < 55$ mA, current spikes of 40 nAs up to 20 MHz, with controlled rise and fall times, filtered overload detection approximately 80 mA, current limitation about 120 mA
- Thermal and short-circuit protections on all card contacts
- Automatic activation and deactivation sequences: initiated by software or by hardware in the event of a short-circuit, card take-off, overheating, V_{DD} or $V_{DD(DCDC)}$ drop-out
- Enhanced ElectroStatic Discharge (ESD) protection on card side (> 6 kV)
- 20 MHz clock input
- Clock generation for the card up to 10 MHz (CLKIN divided by 1, 2, 4 or 5) with synchronous frequency changes; stop HIGH or LOW or free running 1 MHz in cards Low-power mode; current limitation on pin CLK (C3)
- RST signal (C2) with current limitation at 20 mA, controlled by an embedded programmable CLK pulse counter on asynchronous cards or by a register on synchronous cards
- ISO 7816-3, GSM 11.11 and EMVCo 4.3 compatibility
- Supply voltage supervisor for spike killing during power-on and emergency deactivation at power-off: threshold internally fixed or set via an external resistor bridge; pulse width internally fixed or set via an external capacitor
- Card presence input with 10 ms built-in debouncing system
- One interrupt signal \overline{INT}



3. Applications

- Banking terminals
- Internet terminals
- Set-top boxes
- Portable IC card readers

4. Quick reference data

Table 1. Quick reference data

$V_{DD} = 3.3\text{ V}$; $V_{DD(INTF)} = 1.5\text{ V}$; $f_{CLKIN} = 10\text{ MHz}$; $GND = 0\text{ V}$; $T_{amb} = 25\text{ °C}$; unless otherwise specified.

Symbol	Parameter	Conditions	Min	Typ	Max	Unit	
Supply							
V_{DD}	supply voltage	on pin V_{DD}	2.7	-	6.5	V	
$V_{DD(DCDC)}$	DC-to-DC converter supply voltage	on pin V_{DDP}	2.7	-	6.5	V	
$V_{DD(INTF)}$	interface supply voltage	on pin V_{DDI}	1.5	-	6.5	V	
I_{DD}	supply current	Shutdown mode	[1]	-	10	μA	
		Inactive mode; CLKIN LOW or HIGH	[1]	-	200	μA	
		Active mode; $V_{CC} = 5\text{ V}$; $f_{CLK} = 5\text{ MHz}$	[1]				
		capacitive; $I_{CC} = 5\text{ mA}$		-	15	mA	
		capacitive; $I_{CC} = 55\text{ mA}$		-	200	mA	
		inductive; $I_{CC} = 5\text{ mA}$		-	15	mA	
		inductive; $I_{CC} = 55\text{ mA}$		-	150	mA	
		Power-down mode; $V_{CC} = 5\text{ V}$; $I_{CC} = 100\text{ }\mu\text{A}$; CLK stopped; CLKIN HIGH or LOW; capacitive or inductive	[1]	-	2	mA	
Supply voltage for the card: pin V_{CC} [2]							
V_{CC}	supply voltage	Active mode; $2.7\text{ V} < V_{DD} < 6.5\text{ V}$	[3]				
		5 V card; $I_{CC} < 60\text{ mA}$; $V_{CC} = 5\text{ V}$		4.75	5	5.25	V
		3 V card; $I_{CC} < 55\text{ mA}$; $V_{CC} = 3\text{ V}$		2.80	3	3.15	V
		1.8 V card; $I_{CC} < 35\text{ mA}$; $V_{CC} = 1.8\text{ V}$		1.66	1.8	1.94	V
		Active mode; AC current pulses with $I < 200\text{ mA}$, $t < 400\text{ ns}$ and $f < 20\text{ MHz}$	[3]				
		5 V card; current pulses of 40 nAs		4.65	-	5.35	V
		3 V card; current pulses of 24 nAs		2.76	-	3.24	V
		1.8 V card; current pulses of 15 nAs		1.62	-	1.98	V
$V_{ripple(p-p)}$	peak-to-peak ripple voltage	on V_{CC} ; 20 kHz to 200 MHz	-	-	350	mV	
I_{CC}	supply current	$V_{DD} > 2.7\text{ V}$					
		5 V card; $V_{CC} = 0\text{ V to }5\text{ V}$		-	-	-55	mA
		3 V card; $V_{CC} = 0\text{ V to }3\text{ V}$		-	-	-55	mA
		1.8 V card; $V_{CC} = 0\text{ V to }1.8\text{ V}$		-	-	-35	mA

Table 1. Quick reference data ...continued

$V_{DD} = 3.3\text{ V}$; $V_{DD(INTF)} = 1.5\text{ V}$; $f_{CLKIN} = 10\text{ MHz}$; $GND = 0\text{ V}$; $T_{amb} = 25\text{ }^\circ\text{C}$; unless otherwise specified.

Symbol	Parameter	Conditions	Min	Typ	Max	Unit
General						
t_{deact}	deactivation time	total sequence	60	80	100	μs
P_{tot}	total power dissipation	$T_{amb} = -25\text{ }^\circ\text{C}$ to $+85\text{ }^\circ\text{C}$	-	-	500	mW
T_{amb}	ambient temperature		-40	-	+85	$^\circ\text{C}$

- [1] Sum of currents on pins V_{DD} and V_{DDI} .
- [2] Two ceramic multilayer capacitors of minimum 100 nF with low Equivalent Series Resistance (ESR) should be used in order to meet these specifications.
- [3] Output voltage towards the card, including ripple.

5. Ordering information

Table 2. Ordering information

Type number	Package		Version
	Name	Description	
TDA8023TT	TSSOP28	plastic thin shrink small outline package; 28 leads; body width 4.4 mm	SOT361-1

6. Block diagram

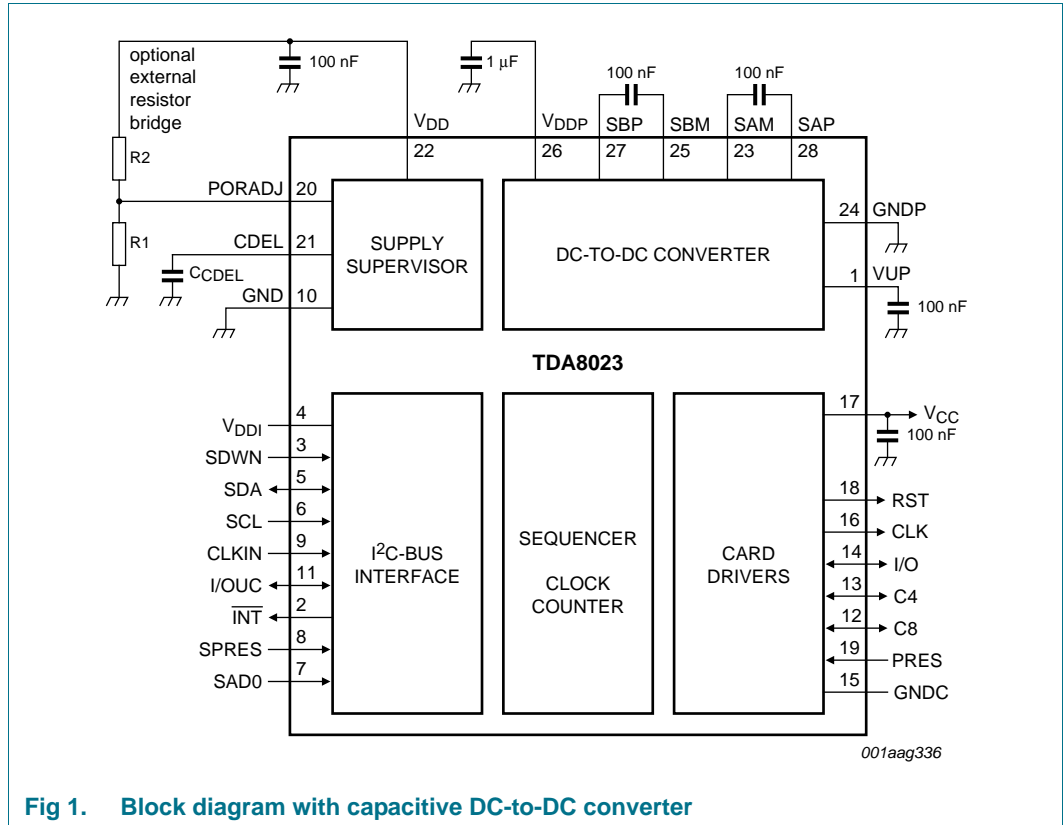

Fig 1. Block diagram with capacitive DC-to-DC converter

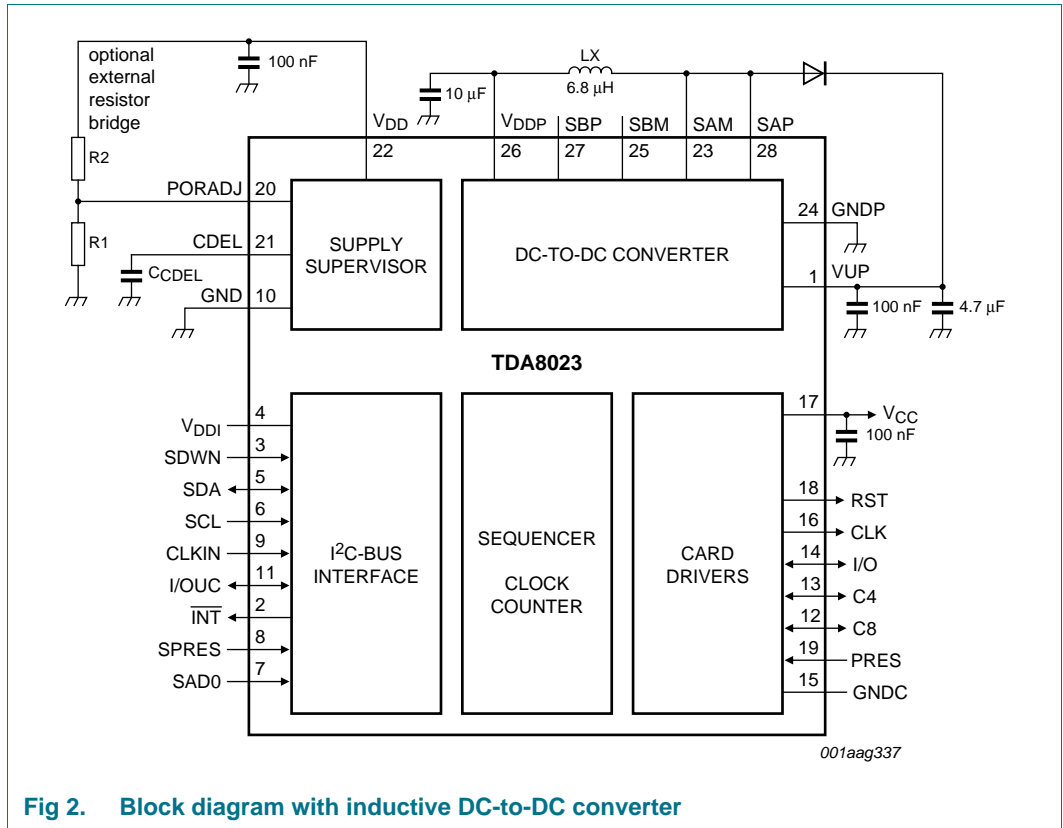

Fig 2. Block diagram with inductive DC-to-DC converter

7. Pinning information

7.1 Pinning

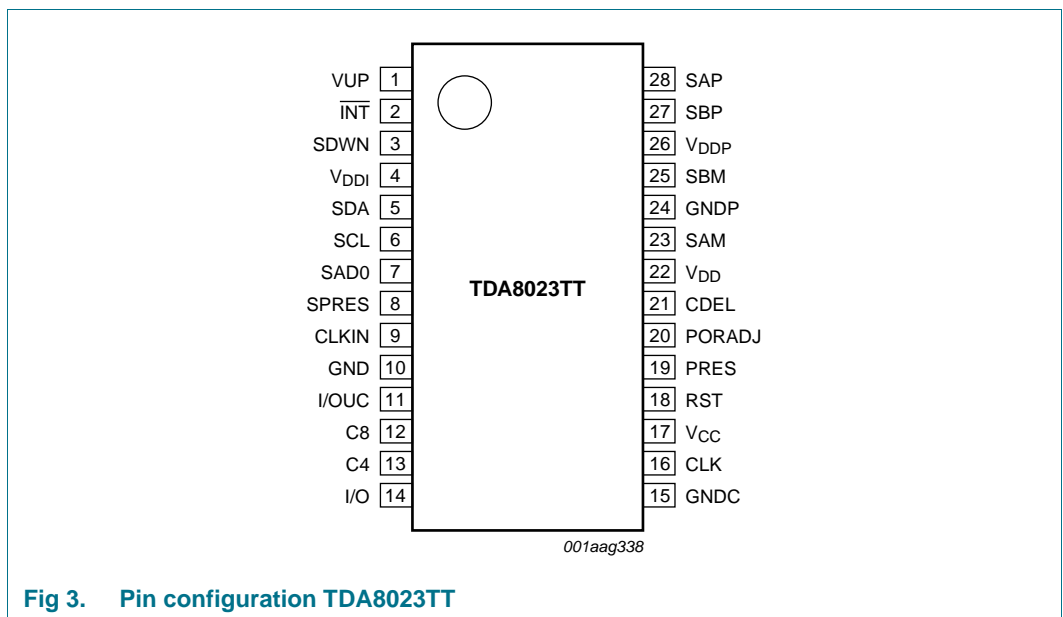

Fig 3. Pin configuration TDA8023TT

7.2 Pin description

Table 3. Pin description

Symbol	Pin	Type ^[1]	Description
VUP	1	O	output of the DC-to-DC converter
$\overline{\text{INT}}$	2	O	Negative-channel Metal Oxide Semiconductor (NMOS) interrupt to the host (active LOW and open-drain) (see fault detection in Section 8.7 "Protection")
SDWN	3	I	shutdown and reset input
V _{DDI}	4	S	interface positive supply voltage
SDA	5	I/O	serial data line to/from the I ² C-bus master (open-drain)
SCL	6	I	serial clock line from the I ² C-bus master
SAD0	7	I	I ² C-bus address selection
SPRES	8	I	select PRES mode ^[2]
CLKIN	9	I	external clock input
GND	10	S	ground connection
I/OUC	11	I/O ^[3]	data in/out from/to microcontroller
C8	12	I/O ^[4]	auxiliary input/output to/from the card (contact C8)
C4	13	I/O ^[4]	auxiliary input/output to/from the card (contact C4)
I/O	14	I/O ^[4]	data input/output to/from (contact C7 of) the card
GNDC	15	S	ground connection for the card (contact C5)
CLK	16	O	clock output to (contact C3 of) the card
V _{CC}	17	S	supply voltage for the card (contact C1)
RST	18	O	reset output to (contact C2 of) the card
PRES	19	I	card presence input with a 10 ms built-in debouncing system ^[2]
PORADJ	20	I	input for changing the power-on reset threshold with an external resistor bridge. In case no external resistor bridge is used, it is mandatory to connect this pin to GND to avoid possible perturbations.
CDEL	21	C	delay capacitor connection for the voltage supervisor (1 ms per 2 nF)
V _{DD}	22	S	power supply
SAM	23	C	connection for the DC-to-DC converter
GNDP	24	S	ground connection for the DC-to-DC converter
SBM	25	C	connection for the DC-to-DC converter
V _{DDP}	26	S	positive supply for the DC-to-DC converter
SBP	27	C	connection for the DC-to-DC converter
SAP	28	C	connection for the DC-to-DC converter

[1] I = input, O = output, S = supply, C = configuration.

[2] PRES is active-HIGH when SPRES = LOW and PRES is active-LOW when SPRES = HIGH.

[3] With integrated pull-up to V_{DD(INTF)}.

[4] With integrated pull-up to V_{CC}.

8. Functional description

Remark: Throughout this document, it is assumed that the reader is familiar with ISO 7816 and EMV terminology.

8.1 Power supplies

The supply pins for the TDA8023 are V_{DD} and GND. V_{DD} should be in the range from 2.7 V to 6.5 V. The supply voltages V_{DD} , $V_{DD(INTF)}$ and $V_{DD(DCDC)}$ may be applied to the TDA8023 in any time sequence.

All interface signals with the system controller are referenced to a separate supply voltage $V_{DD(INTF)}$ on pin V_{DDI} , that may be lower or higher than V_{DD} .

For generating a supply voltage V_{CC} of $5 V \pm 5 \%$ or $3 V \pm 5 \%$ used by the card, an integrated DC-to-DC converter is incorporated. This DC-to-DC converter should be separately supplied by $V_{DD(DCDC)}$ on pin V_{DDP} and GNDP (from 2.7 V to 6.5 V).

The I²C-bus signals SDA and SCL may be externally referenced to a voltage higher than V_{DD} .

8.2 Voltage supervisor

8.2.1 Without external divider on pin PORADJ

The voltage supervisor surveys the V_{DD} supply voltage. It is used as Power-On Reset (POR) and as supply dropout detection during a card session. Supply dropout detection ensures that a proper deactivation sequence is followed before the voltage is too low. A reset pulse of duration t_W (see Figure 4) is used internally for maintaining the TDA8023 in the Inactive mode during powering up or powering down of V_{DD} .

As long as V_{DD} is less than $V_{th(POR)H}$ the TDA8023 will remain inactive whatever the levels on the command lines are. This also lasts for the duration of t_W after V_{DD} has reached a level higher than $V_{th(POR)H}$. When V_{DD} falls below $V_{th(POR)L}$ an automatic deactivation sequence of the contacts is performed.

In this case (no external resistor bridge) it is mandatory to connect pin PORADJ to GND.

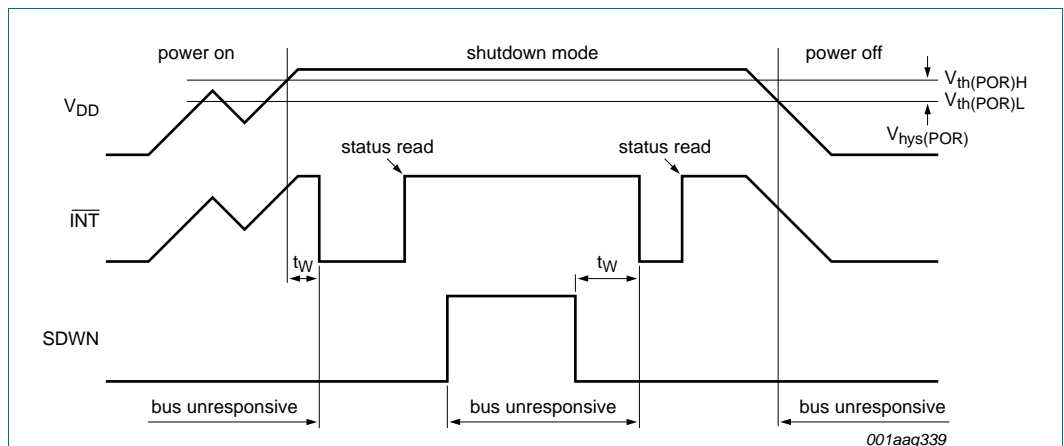

Fig 4. Voltage supervisor and Shutdown mode

8.2.2 With external divider on pin PORADJ

If an external resistor bridge is connected to pin PORADJ (R1 to GND and R2 to V_{DD} as shown in [Figure 1](#) and [Figure 2](#)), then the internal threshold voltages and the internal hysteresis voltage are overridden by externally determined ones.

The voltage on pin PORADJ is:

$$V_{PORADJ} = \frac{R1}{R1 + R2} \times V_{DD} = k \times V_{DD}$$

where

$$k = \frac{R1}{R1 + R2}$$

The thresholds that are applied by the TDA8023 to this voltage V_{PORADJ} are:

$$V_{th(H)(PORADJ)} = V_{bg(int)} + \frac{V_{hys}}{2} \quad (\text{rising})$$

$$V_{th(L)(PORADJ)} = V_{bg(int)} - \frac{V_{hys}}{2} \quad (\text{falling})$$

where

$$V_{bg(int)} = 1.25 \text{ V (typ)}$$

$$V_{hys} = 60 \text{ mV (typ)}$$

The thresholds and hysteresis on V_{DD} can then be calculated from:

$$V_{th(POR)H} = \frac{V_{th(H)(PORADJ)}}{k} = \frac{\left(V_{bg(int)} + \frac{V_{hys}}{2} \right)}{k} \quad (\text{rising})$$

$$V_{th(POR)L} = \frac{V_{th(L)(PORADJ)}}{k} = \frac{\left(V_{bg(int)} - \frac{V_{hys}}{2} \right)}{k} \quad (\text{falling})$$

$$V_{hys(POR)} = \frac{V_{hys}}{k}$$

The minimum threshold voltage V_{th(POR)L} should be chosen higher than 2 V.

Input PORADJ is biased internally with a pull-down current source of 4 μA which is cut when the voltage on this pin exceeds 1 V. This ensures that after detection of the external bridge during power-on, the input current on this pin does not cause inaccuracy of the bridge voltage.

8.2.3 External capacitor on pin CDEL

The width of the POR pulse (t_W) is externally set by the value of the CDEL capacitor: the typical value is 1 ms per 2 nF. Usually C_{CDEL} = 22 nF, therefore t_W = 10 ms (typ).

8.2.4 Shutdown mode

When pin SDWN = HIGH, the TDA8023 is in Shutdown mode; the consumption in this mode is less than 10 μ A. The I²C-bus is unresponsive.

If the card is extracted or inserted when the TDA8023 is in Power-down mode, pin $\overline{\text{INT}}$ becomes LOW and stays LOW as long as pin SDWN = HIGH.

When pin SDWN is pulled LOW, the TDA8023 leaves Shutdown mode and executes a complete power-on reset sequence.

8.3 I²C-bus

A 400 kHz I²C-bus slave interface is used for configuring the TDA8023 and reading the status.

8.3.1 I²C-bus protocol

The I²C-bus is for 2-way 2-line communication between ICs or modules. The serial bus consists of two bidirectional lines: one for data signals (SDA) and one for clock signals (SCL).

Both the SDA and SCL lines must be connected to a positive supply voltage via a pull-up resistor.

The following protocol has been defined:

- Data transfer may be initiated only when the bus is not busy
- During data transfer, the data line must remain stable whenever the clock line is HIGH; changes in the data line while the clock line is HIGH will be interpreted as control signals

8.3.2 Bus conditions

The following bus conditions have been defined.

Bus not busy — Both data and clock lines remain HIGH.

Start data transfer — A change in the state of the data line from HIGH to LOW, while the clock is HIGH, defines the START condition.

Stop data transfer — A change in the state of the data line from LOW to HIGH, while the clock is HIGH, defines the STOP condition.

Data valid — The state of the data line represents valid data when, after a START condition, the data line is stable for the duration of the HIGH period of the clock signal. There is one clock pulse per bit of data.

8.3.3 Data transfer

Each data transfer is initiated with a START condition and terminated with a STOP condition (see [Figure 7](#)). See [Table 15](#) for timing information.

Data transfer is unlimited in the Read mode. The information is transmitted in bytes and each receiver acknowledges with a 9th bit.

Within the I²C-bus specifications, a Standard mode (100 kHz clock rate) and a Fast-speed mode (400 kHz clock rate) are defined. The TDA8023 operates in both Fast-speed and Standard modes.

By definition, a device that sends a signal is called a transmitter and a device that receives the signal is called a receiver. The device that controls the signal is called the master. The devices that are controlled by the master are called slaves.

Each byte is followed by one acknowledge bit. This acknowledge bit is a HIGH level, put on the bus by the transmitter. The master generates an extra acknowledge-related clock pulse. The slave receiver that is addressed is obliged to generate an acknowledge after the reception of each byte.

The master receiver must generate an acknowledge after the reception of each byte that has been clocked out of the slave transmitter.

The device that acknowledges has to pull down the SDA line during the acknowledge clock pulse in such a way that the SDA line is stable LOW during the HIGH period of the acknowledge-related clock pulse.

Set-up and hold times must be taken into account. A master receiver must signal an end of data to the slave transmitter by not generating an acknowledge on the last byte that has been clocked out of the slave. In this event, the transmitter must leave the data line HIGH to enable the master generation of the STOP condition.

8.3.4 Device addressing

Each TDA8023 has 2 different addresses, one for each of its two registers.

Two TDA8023s may be used in parallel due to the address selection pin SAD0. Pin SAD0 is externally hardwired to pin V_{DD} or pin GND. The voltage on pin SAD0 sets address bit b2: HIGH sets bit b2 to logic 1, LOW resets b2 to logic 0.

Address bit b1 selects Register 0 or Register 1.

Address bit b0 defines Read or Write operation: 1 means Read, 0 means Write.

The addresses for the TDA8023 are shown in [Table 4](#) and [Table 5](#).

Table 4. Device addressing

b7	b6	b5	b4	b3	b2	b1	b0
0	1	0	0	0	SAD0	0/1	R/W

Table 5. I²C-bus addresses for write mode

Pin SAD0	Register 0	Register 1
L	40h	42h
H	44h	46h

8.3.5 Registers

Table 6. Table of registers

Bit	Register 0		Register 1			
	Read mode Status	Write mode Command	Read/Write mode			
			REG1 = 0		REG1 = 1	
			REG0 = 0	REG0 = 1	REG0 = 0	REG0 = 1
7	ACTIVE	VCC1V8	TEST	D7	C15	C7
6	EARLY	I/OEN	RSTIN	D6	C14	C6
5	MUTE	REG1	C8	D5	C13	C5
4	PROT	REG0	C4	D4	C12	C4
3	SUPL	PDWN	CLKPD2	D3	C11	C3
2	CLKSW	5V/3VN	CLKPD1	D2	C10	C2
1	PRESL	WARM	CLKDIV2	D1	C9	C1
0	PRES	START	CLKDIV1	D0	C8	C0

Table 7. Status - Register 0 in Read mode bit description

Bit	Symbol	Description
7	ACTIVE	set if the card is active; reset if the card is inactive
6	EARLY	set during Answer To Reset (ATR) when the selected card has answered too early
5	MUTE	set during ATR when the card has not answered during the ISO 7816 time slots
4	PROT	set when an overload or an overheating has occurred during a session; reset when the status has been read
3	SUPL	set when the voltage supervisor has signalled a fault; reset when the status has been read
2	CLKSW	set when the TDA8023 is in Power-down mode and the clock has changed
1	PRESL	set when the card has been inserted or extracted; reset when the status has been read
0	PRES	set when the card is present; reset when the card is not present

When at least one of the bits PRESL, PROT, MUTE and EARLY is set, pin \overline{INT} goes LOW until the status byte has been read. After power-on, bit SUPL is set until the status byte has been read, and pin \overline{INT} = LOW until the voltage supervisor becomes inactive.

Table 8. Command - Register 0 in Write mode bit description

Bit	Symbol	Description
7	VCC1V8	1: V _{CC} = 1.8 V 0: V _{CC} is defined by bit 5V/3VN this bit can not change if bit START is logic 1
6	I/OEN	1: signal on pin I/OUC is transferred to pin I/O 0: pin I/OUC and pin I/O are high-impedance
5 and 4	REG[1:0]	selection of subaddress in Register 1 (see Table 9 , 10 , 11 and 12)

Table 8. Command - Register 0 in Write mode bit description ...continued

Bit	Symbol	Description
3	PDWN	1: applies on pin CLK the frequency that is defined by bits CLKPD[2:1] and reduces power consumption (in Synchronous mode); this bit can not change if bit START is logic 1
2	5V/3VN	1: V _{CC} = 5 V 0: V _{CC} = 3 V this bit can not change if bit START is logic 1
1	WARM	1: initiates a warm reset procedure this bit will be automatically reset by hardware when bit MUTE is set to logic 1
0	START	1: initiates an activation sequence and a cold reset procedure (only if bit SUPPL = 0 and the bit PRES = 1) 0: initiates a deactivation sequence

Table 9. R1_00 - Register 1 subaddress 00 in Read/Write mode bit description

Bit	Symbol	Description
7	TEST	1: the circuit is in Test mode 0: the circuit is in Operational mode
6	RSTIN ^[1]	defines the voltage on pin RST: 1: V _{CC} 0: 0 V
5	C8	defines the voltage on pin C8: 1: V _{CC} 0: 0 V
4	C4	defines the voltage on pin C4: 1: V _{CC} 0: 0 V
3 and 2	CLKPD[2:1]	clock pulse definition: 00: CLK stop LOW 01: CLK stop HIGH 10: frequency on pin CLK: $f_{CLK} = f_{osc(int)} / 2$ 11: no change in Synchronous mode bit CLKPD2 is always logic 0 by hardware and bit CLKPD1 controls the voltage on pin CLK: 1: V _{CC} 0: 0 V
1 and 0	CLKDIV[2:1]	clock divider: 00: $f_{CLK} = f_{CLKIN}$ 01: $f_{CLK} = f_{CLKIN} / 2$ 10: $f_{CLK} = f_{CLKIN} / 4$ 11: $f_{CLK} = f_{CLKIN} / 5$ in Synchronous mode, bits CLKDIV[2:1] are always 00 by hardware

[1] Synchronous or asynchronous cards management are defined when bit START is set: the TDA8023 will be in asynchronous cards management when bit RSTIN = 1 when bit START is set to logic 1.

Table 10. R1_01 - Register 1 subaddress 01 in Read/Write mode bit description

Bit	Symbol	Description
7 to 0	D[7:0]	8-bit programmable CLK period count register; range: 0 to 255; initial value: 170

Table 11. R1_10 - Register 1 subaddress 10 in Read/Write mode bit description

Bit	Symbol	Description
7 to 0	C[15:8]	8-bit programmable CLK period count register; range in combination with C[7:0]: 0 to 65535; initial value: 164

Table 12. R1_11 - Register 1 subaddress 11 in Read/Write mode bit description

Bit	Symbol	Description
7 to 0	C[7:0]	8-bit programmable CLK period count register; range in combination with C[15:8]: 0 to 65535; initial value: 116

If bit RSTIN = 0 when bit START is set to logic 1, then pin RST is controlled by bit RSTIN. Else, pin RST = LOW during a number of CLK periods, defined by the 16-bit CLK count register C[15:0], and goes HIGH afterwards.

There are two synchronous card management types:

- If bit PDWN = 0 when bit START is set to logic 1, then the output CLK is controlled by input CLKIN (without division)
- If bit PDWN = 1 when bit START is set to logic 1, then the output CLK is controlled by bit CLKPD1

8.4 DC-to-DC converter

For generating a supply voltage V_{CC} of $5\text{ V} \pm 5\%$ or $3\text{ V} \pm 5\%$ to the card, an integrated voltage converter is incorporated. This DC-to-DC converter should be separately supplied by $V_{DD(DCDC)}$ on pin V_{DDP} and $GNDP$ (from 2.7 V to 6.5 V).

The DC-to-DC conversion is either capacitive or inductive, according to the external components (automatic detection).

8.4.1 Capacitive configuration

The external components are three 100 nF capacitors (low-ESR), see [Figure 1](#).

The DC-to-DC converter is either tripler, doubler or follower according to the respective values of V_{CC} and $V_{DD(DCDC)}$. An hysteresis of 100 mV is present on both thresholds:

- Follower:
 - If $V_{CC} = 5\text{ V}$ and $V_{DD(DCDC)} > 5.8\text{ V}$
 - If $V_{CC} = 3\text{ V}$ and $V_{DD(DCDC)} > 4\text{ V}$
 - If $V_{CC} = 1.8\text{ V}$

- Doubler:
 - If $V_{CC} = 5\text{ V}$ and $V_{DD(DCDC)} = 4\text{ V}$ to 5.8 V
 - If $V_{CC} = 3\text{ V}$ and $V_{DD(DCDC)} < 4\text{ V}$
- Tripler:
 - If $V_{CC} = 5\text{ V}$ and $V_{DD(DCDC)} < 4\text{ V}$

8.4.2 Inductive configuration

The external components are a diode, a coil of $6.8\text{ }\mu\text{H}$ and a capacitor of $4.7\text{ }\mu\text{F}$ (see [Figure 2](#)). In this configuration the DC-to-DC converter acts as follows.

- If $V_{CC} = 5\text{ V}$ then V_{VUP} is regulated at 5.5 V
- If $V_{CC} = 3\text{ V}$ then V_{VUP} is regulated at 4 V
- If $V_{CC} = 1.8\text{ V}$ then the DC-to-DC converter acts as a follower

8.5 V_{CC} buffer

In all modes (follower, doubler, tripler), the DC-to-DC converter is able to deliver 60 mA over the whole V_{DD} range (2.7 V to 6.5 V) or 90 mA if $V_{DD} > 3\text{ V}$.

The current on the V_{CC} buffer has an internal limitation of around 90 mA . When this limit is reached, an automatic deactivation sequence is performed.

The V_{CC} voltage should be decoupled with a low-ESR capacitor between 100 nF and 168 nF . If the card socket is not very close to the TDA8023, one capacitor should be placed near the TDA8023, and a second one near the card contacts.

8.6 Sequencer and clock counter

The sequencer takes care of ensuring activation and deactivation sequences according to ISO 7816 and EMVCo 4.3, even in case of emergency (card removal during transaction, supply dropout or hardware problem).

The sequencer is clocked with an internal oscillator.

The activation of a card is initiated by setting bit START in the Command register, which is only possible if the card is present and if the voltage supervisor is not active. The activation sequence is described in [Section 8.6.1](#).

The deactivation is initiated either by the system controller or automatically in case of a hardware problem or a supply dropout. The deactivation sequence is described in [Section 8.6.2](#).

Outside a session, card contacts are forced low-impedance with respect to pin GNDC.

8.6.1 Activation sequence

When the card is inactive, pins V_{CC} , CLK, RST and I/O are LOW, which is low-impedance with respect to pin GNDC. The DC-to-DC converter is stopped.

When everything is satisfactorily present (voltage supply, card present, no hardware problems) the system controller may initiate an activation sequence of a present card:

1. The internal oscillator changes to its high frequency (t_0 , see [Figure 5](#)).
2. The DC-to-DC converter is started (t_1).
3. V_{CC} starts rising from 0 V to 5 V, 3 V or 1.8 V with a controlled rise time (t_2).
4. The voltage on pin I/O rises to V_{CC} , due to integrated 14 k Ω pull-ups to V_{CC} (t_3).
5. CLK is sent to the card and pin RST is enabled ($t_4 = t_{act}$).

During the activation sequence, the answer from the card (ATR) is monitored and the steps are the following:

1. If a start bit is detected on pin I/O during the first 200 CLK pulses, then it is simply ignored, and the CLK count goes on.
2. If a start bit is detected whilst pin RST = LOW (between 200 and 42100 CLK pulses or the value written in C[15:0]), then the bits EARLY and MUTE are set in the Status register. Pin RST will remain LOW. It is up to the software to decide whether to accept the card or not.
3. If no start bit has been detected within 42100 CLK pulses, then pin RST is toggled to HIGH (t_5).
4. If, again, a start bit is detected within 370 CLK pulses (200 + 170 or the value defined in D[7:0]), bit EARLY in the Status register is set.
5. If the card does not answer within 42100 new CLK pulses, then bit MUTE in the Status register is set.
6. If the card answers within the correct time window, then the CLK count is stopped and the system controller can send commands to the card.

The sequencer is clocked by $\frac{f_{osc(int)}}{64}$ which leads to a time interval $T = 25 \mu s$ (typical).

Thus $t_1 = 0$ s to $\frac{T}{64}$, $t_2 = t_1 + \frac{3T}{2}$, $t_3 = t_1 + \frac{7T}{2}$ and $t_4 = t_1 + 4T$.

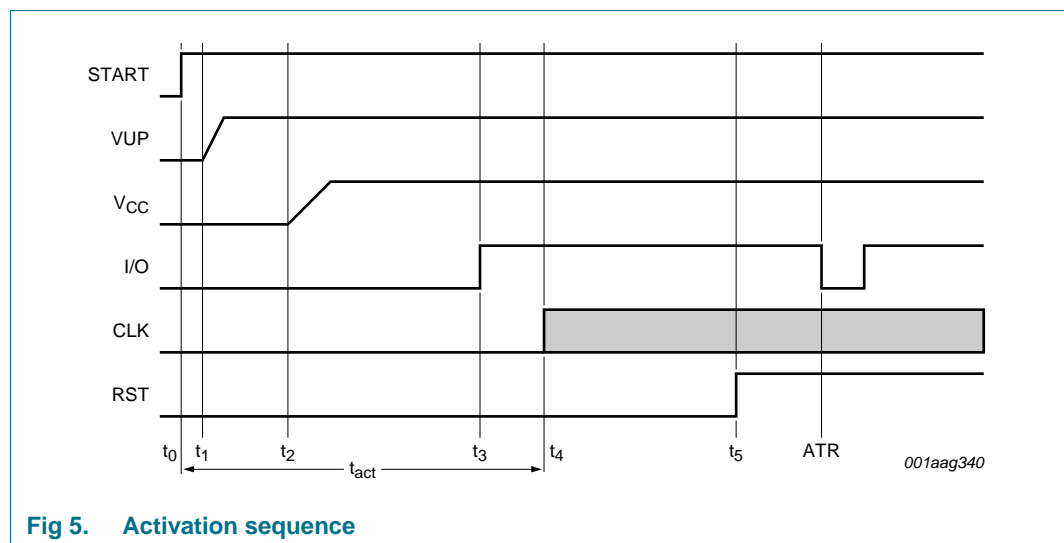

Fig 5. Activation sequence

8.6.2 Deactivation sequence

When the session is completed, the microcontroller resets bit START to logic 0 (t_{10} , see [Figure 6](#)). The circuit then executes an automatic deactivation sequence:

1. Card reset: pin RST falls to LOW (t_{11}).
2. CLK is stopped (t_{12}).
3. Pin I/O falls to 0 V (t_{13}).
4. Pin V_{CC} falls to 0 V with a controlled slew rate (t_{14}).
5. The DC-to-DC converter is stopped and pins CLK, RST, V_{CC} and I/O become low-impedance with relation to GNDC (t_{15}).
6. The internal oscillator changes to its low frequency (t_{15}).

$$t_{11} = t_{10} + \frac{T}{64}, t_{12} = t_{11} + \frac{T}{2}, t_{13} = t_{11} + T, t_{14} = t_{11} + \frac{3T}{2} \text{ and } t_{15} = t_{11} + \frac{7T}{2}.$$

The deactivation time t_{deact} is the time that V_{CC} needs for going down to less than 0.4 V, counted from the moment bit START is reset.

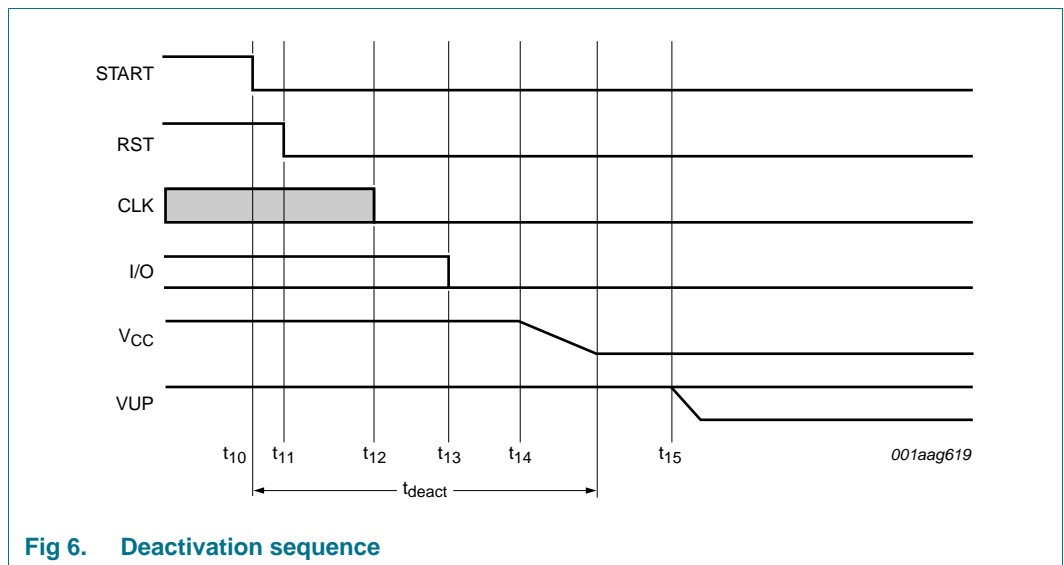

Fig 6. Deactivation sequence

8.7 Protection

All card contacts are protected against any short with any other card contact.

The currents on various pins are limited:

- on pin CLK: limited to ± 70 mA
- on pin I/O: limited to ± 10 mA (typical value)
- on pin RST: limited (only when this pin is LOW) to ± 20 mA
- on pin V_{CC} : limited to 90 mA

If any of these currents exceeds its limit, an emergency deactivation sequence is performed: pin \overline{INT} is pulled LOW and bit PROT in the Status register is set.

In case of overcurrent on pin V_{CC} , removal of the card during a session, overheating, supply dropout, DC-to-DC out of limits, or overcurrent on pin RST, the TDA8023 performs an automatic emergency deactivation sequence on the card, resets bit START and pulls pin INT LOW.

9. Limiting values

Table 13. Limiting values

In accordance with the Absolute Maximum Rating System (IEC 60134).

Symbol	Parameter	Conditions	Min	Max	Unit
V_{DD}	supply voltage	on pin V_{DD}	-0.5	+6.5	V
$V_{DD(DCDC)}$	DC-to-DC converter supply voltage	on pin V_{DDP}	-0.5	+6.5	V
$V_{DD(INTF)}$	interface supply voltage	on pin V_{DDI}	-0.5	+6.5	V
V_{IH}	HIGH-level input voltage	on pins SAP, SAM, SBP, SBM, VUP	-0.5	+7.5	V
		on pins SDA, SCL	-0.5	+6.5	V
		on all other pins	-0.5	$V_{DD} + 0.5$	V
P_{tot}	total power dissipation	$T_{amb} = -25\text{ °C to }+85\text{ °C}$	-	500	mW
T_{stg}	storage temperature		-55	+150	°C
T_j	junction temperature		-	150	°C
V_{esd}	electrostatic discharge voltage	Human Body Model (HBM) [1]			
		on card pins I/O, V_{CC} , CLK, GNDC, PRES, RST	-6	+6	kV
		on all other pins	-2	+2	kV
		Machine Model (MM)			
	all pins, excluding card pins		-200	+200	V

[1] Every pin withstands the ESD test according to MIL-STD-883C class 3 for card contacts, class 2 for the remaining. Method 3015 (HBM; 1500 Ω ; 100 pF) defines 3 pulses positive and 3 pulses negative on each pin referenced to ground.

10. Thermal characteristics

Table 14. Thermal characteristics

Symbol	Parameter	Conditions	Typ	Unit
$R_{th(j-a)}$	thermal resistance from junction to ambient	in free air	100	K/W

11. Characteristics

Table 15. Supply

$V_{DD} = 3.3\text{ V}$; $V_{DD(INTF)} = 1.5\text{ V}$; $f_{CLKIN} = 10\text{ MHz}$; $GND = 0\text{ V}$; $T_{amb} = 25\text{ °C}$; unless otherwise specified.

Symbol	Parameter	Conditions	Min	Typ	Max	Unit	
V_{DD}	supply voltage	on pin V_{DD}	2.7	-	6.5	V	
$V_{DD(DCDC)}$	DC-to-DC converter supply voltage	on pin V_{DDP}	2.7	-	6.5	V	
$V_{DD(INTF)}$	interface supply voltage	on pin V_{DDI}	1.5	-	6.5	V	
I_{DD}	supply current	Shutdown mode	[1]	-	10	μA	
		Inactive mode; CLKIN LOW or HIGH	[1]	-	200	μA	
		Active mode; $V_{CC} = 5\text{ V}$; $f_{CLK} = 5\text{ MHz}$	[1]	-	-	-	-
		capacitive; $I_{CC} = 5\text{ mA}$	-	-	15	mA	
		capacitive; $I_{CC} = 55\text{ mA}$	-	-	200	mA	
		inductive; $I_{CC} = 5\text{ mA}$	-	-	15	mA	
		inductive; $I_{CC} = 55\text{ mA}$	-	-	150	mA	
$I_{DD(INTF)}$	interface supply current	on pin V_{DDI}	-	-	120	μA	
$V_{th(POR)L}$	LOW-level power-on reset threshold voltage	decreasing voltage on pin V_{DD} ; see Figure 4	2.30	-	2.60	V	
$V_{hys(POR)}$	power-on reset hysteresis voltage	on pin V_{DD} ; see Figure 4	50	-	150	mV	

[1] Sum of currents on pins V_{DD} and V_{DDI} .

Table 16. Supply supervisor

$V_{DD} = 3.3\text{ V}$; $V_{DD(INTF)} = 1.5\text{ V}$; $f_{CLKIN} = 10\text{ MHz}$; $GND = 0\text{ V}$; $T_{amb} = 25\text{ °C}$; unless otherwise specified.

Symbol	Parameter	Conditions	Min	Typ	Max	Unit
Pin PORADJ						
$V_{th(H)(PORADJ)}$	HIGH-level threshold voltage on pin PORADJ	rising voltage; see Section 8.2.2	1.25	1.28	1.31	V
$V_{th(L)(PORADJ)}$	LOW-level threshold voltage on pin PORADJ	falling voltage; see Section 8.2.2	1.19	1.22	1.25	V
V_{hys}	hysteresis voltage	$V_{th(H)(PORADJ)} - V_{th(L)(PORADJ)}$; see Section 8.2.2	30	60	90	mV
$\Delta V_{th}/\Delta T$	threshold voltage variation with temperature	on $V_{th(H)(PORADJ)}$ and $V_{th(L)(PORADJ)}$	-	-	0.25	mV/°C
I_L	leakage current	$V_{PORADJ} < 0.6\text{ V}$	0	4	10	μA
		$V_{PORADJ} > 0.8\text{ V}$	-1	-	+1	μA
Pin CDEL						
V_{CDEL}	voltage on pin CDEL		-	-	$V_{DD} + 0.3$	V
I_{CDEL}	current on pin CDEL	pin grounded (charge)	-	-2	0	μA
		$V_{CDEL} = V_{DD}$ (discharge)	-	-5	-	mA
t_W	pulse width	internal alarm pulse; $C_{CDEL} = 22\text{ nF}$	-	10	-	ms

Table 17. DC-to-DC converter

$V_{DD} = 3.3\text{ V}$; $V_{DD(INTF)} = 1.5\text{ V}$; $f_{CLKIN} = 10\text{ MHz}$; $GND = 0\text{ V}$; $T_{amb} = 25\text{ °C}$; unless otherwise specified.

Symbol	Parameter	Conditions	Min	Typ	Max	Unit
$f_{osc(int)}$	internal oscillator frequency		2	2.5	3	MHz
V_{VUP}	voltage on pin VUP	5 V card	5.3	5.5	5.8	V
		3 V card	3.5	4	4.2	V
		1.8 V card	-	$V_{DD(DCDC)}$	-	V
V_{det}	detection voltage	on pin V_{DDP}				
		5 V card; Follower mode	5.5	5.8	6	V
		3 V card; Follower mode	3.8	4	4.2	V
		5 V card; Tripler mode	-	3.5	-	V

Table 18. Card drivers

$V_{DD} = 3.3\text{ V}$; $V_{DD(INTF)} = 1.5\text{ V}$; $f_{CLKIN} = 10\text{ MHz}$; $GND = 0\text{ V}$; $T_{amb} = 25\text{ °C}$; unless otherwise specified.

Symbol	Parameter	Conditions	Min	Typ	Max	Unit
Supply voltage for the card: pin V_{CC}^[1]						
$V_{o(inact)}$	inactive mode output voltage	no load	0	-	0.1	V
		$I_{o(inact)} = 1\text{ mA}$	0	-	0.3	V
$I_{o(inact)}$	inactive mode output current	at grounded pin V_{CC}	-	-	-1	mA
V_{CC}	supply voltage	Active mode; $2.7\text{ V} < V_{DD} < 6.5\text{ V}$	[2]			
		5 V card; $I_{CC} < 60\text{ mA}$; $V_{CC} = 5\text{ V}$	4.75	5	5.25	V
		3 V card; $I_{CC} < 55\text{ mA}$; $V_{CC} = 3\text{ V}$	2.80	3	3.15	V
		1.8 V card; $I_{CC} < 35\text{ mA}$; $V_{CC} = 1.8\text{ V}$	1.66	1.8	1.94	V
		Active mode; AC current pulses with $I < 200\text{ mA}$, $t < 400\text{ ns}$ and $f < 20\text{ MHz}$	[2]			
		5 V card; current pulses of 40 nAs	4.65	-	5.35	V
		3 V card; current pulses of 24 nAs	2.76	-	3.24	V
		1.8 V card; current pulses of 15 nAs	1.62	-	1.98	V
$V_{ripple(p-p)}$	peak-to-peak ripple voltage	on V_{CC} ; $20\text{ kHz} < f < 200\text{ MHz}$	-	-	350	mV
I_{CC}	supply current	$V_{DD} > 2.7\text{ V}$				
		5 V card; $V_{CC} = 0\text{ V}$ to 5 V	-	-	-55	mA
		3 V card; $V_{CC} = 0\text{ V}$ to 3 V	-	-	-55	mA
		1.8 V card; $V_{CC} = 0\text{ V}$ to 1.8 V	-	-	-35	mA
		V_{CC} shorted to GND				
		5 V card or 3 V card	-	-90	-120	mA
	1.8 V card	-	-70	-90	mA	
SR	slew rate	rise or fall; maximum load capacitor $C_L = 300\text{ nF}$				
		5 V card	0.080	0.140	0.200	V/ μs
		3 V card	0.050	0.080	0.110	V/ μs
		1.8 V card	0.025	0.045	0.080	V/ μs

Table 18. Card drivers ...continued

$V_{DD} = 3.3\text{ V}$; $V_{DD(INTF)} = 1.5\text{ V}$; $f_{CLKIN} = 10\text{ MHz}$; $GND = 0\text{ V}$; $T_{amb} = 25\text{ °C}$; unless otherwise specified.

Symbol	Parameter	Conditions	Min	Typ	Max	Unit
Reset output to the card: pin RST						
$V_{o(inact)}$	inactive mode output voltage	no load	0	-	0.1	V
		$I_{o(inact)} = 1\text{ mA}$	0	-	0.3	V
$I_{o(inact)}$	inactive mode output current	at grounded pin RST	0	-	-1	mA
V_{OL}	LOW-level output voltage	$I_{OL} = 200\text{ }\mu\text{A}$	0	-	$0.15\text{ }V_{CC}$	V
V_{OH}	HIGH-level output voltage	$I_{OH} < -200\text{ }\mu\text{A}$	$V_{CC} - 0.5$	-	V_{CC}	V
t_r	rise time	$C_L = 30\text{ pF}$	-	-	0.1	μs
t_f	fall time	$C_L = 30\text{ pF}$	-	-	0.1	μs
Clock output to the card: pin CLK						
$V_{o(inact)}$	inactive mode output voltage	no load	0	-	0.1	V
		$I_{o(inact)} = 1\text{ mA}$	0	-	0.3	V
$I_{o(inact)}$	inactive mode output current	at grounded pin CLK	0	-	-1	mA
V_{OL}	LOW-level output voltage	$I_{OL} = 200\text{ }\mu\text{A}$	0	-	$0.15\text{ }V_{CC}$	V
V_{OH}	HIGH-level output voltage	$I_{OH} < -200\text{ }\mu\text{A}$	$V_{CC} - 0.5$	-	V_{CC}	V
t_r	rise time	$C_L = 30\text{ pF}$	-	-	8	ns
t_f	fall time	$C_L = 30\text{ pF}$	-	-	8	ns
f_{CLK}	frequency on pin CLK	operational	0	-	10	MHz
δ	clock duty cycle	$C_L = 30\text{ pF}$	45	-	55	%
SR	slew rate	rise and fall; $C_L = 30\text{ pF}$	0.2	-	-	V/ns
Data lines: pins I/O, C4 and C8						
$V_{o(inact)}$	inactive mode output voltage	no load	0	-	0.1	V
		$I_{o(inact)} = 1\text{ mA}$	-	-	0.3	V
$I_{o(inact)}$	inactive mode output current	at grounded pin I/O	[3]	-	-1	mA
V_{OL}	LOW-level output voltage	$I_{OL} = 1\text{ mA}$	0	-	$0.15\text{ }V_{CC}$	V
V_{OH}	HIGH-level output voltage	no DC load	$0.9V_{CC}$	-	$V_{CC} + 0.1$	V
		$I_{OH} < -20\text{ }\mu\text{A}$	$0.8V_{CC}$	-	$V_{CC} + 0.1$	V
		$I_{OH} < -40\text{ }\mu\text{A}$	$0.75V_{CC}$	-	$V_{CC} + 0.1$	V
V_{IL}	LOW-level input voltage		-0.3	-	$0.2\text{ }V_{CC}$	V
V_{IH}	HIGH-level input voltage		$0.6\text{ }V_{CC}$	-	V_{CC}	V
I_{IL}	LOW-level input current	at pin I/O; $V_{IL} = 0\text{ V}$	[3]			
		$V_{CC} = 5\text{ V}$	-	-	600	μA
		$V_{CC} = 3\text{ V}$	-	-	500	μA
I_{LIH}	HIGH-level input leakage current	at pin I/O; $V_{IH} = V_{CC}$	[3]	-	10	μA

Table 18. Card drivers ...continued

$V_{DD} = 3.3\text{ V}$; $V_{DD(INTF)} = 1.5\text{ V}$; $f_{CLKIN} = 10\text{ MHz}$; $GND = 0\text{ V}$; $T_{amb} = 25\text{ }^{\circ}\text{C}$; unless otherwise specified.

Symbol	Parameter	Conditions	Min	Typ	Max	Unit
I_{pu}	pull-up current	at pin I/O; $V_{OH} = 0.9V_{CC}$; $C_L = 30\text{ pF}$	[3] -1	-	-	mA
t_d	delay time	between edges on pin I/O and pin I/OUC; corresponds to width of active pull-up pulse	[3][4] -	500	650	ns
t_r	rise time	inputs; from $V_{IL(max)}$ to $V_{IH(min)}$	-	-	1.5	μs
t_R and t_F	IO rise and fall time	output transition time; from 10 % of V_{CC} to 90 % of V_{CC} ; $C_L < 30\text{ pF}$; no DC load	-	-	0.1	μs
C_i	input capacitance	on pin I/O	[3] -	-	10	pF
$R_{pu(int)}$	internal pull-up resistance	between pin I/O and V_{CC}	[3] 10	13.5	17	k Ω
f_{max}	maximum input clock frequency	on pin I/O	[3] -	-	500	kHz
Card presence input: pin PRES, active-HIGH when pin SPRES = LOW or active-LOW when pin SPRES = HIGH						
V_{IL}	LOW-level input voltage		-	-	$0.3V_{DD}$	V
V_{IH}	HIGH-level input voltage		$0.7V_{DD}$	-	-	V
I_{LIL}	LOW-level input leakage current	$V_I = 0.3V_{DD}$; pin SPRES = HIGH	0	-	5	μA
		$V_I = 0.3V_{DD}$; pin SPRES = LOW	10	-	40	μA
I_{LIH}	HIGH-level input leakage current	$V_I = 0.7V_{DD}$; pin SPRES = HIGH	-40	-	-10	μA
		$V_I = 0.7V_{DD}$; pin SPRES = LOW	-5	-	0	μA

- [1] Two ceramic multilayer capacitors of minimum 100 nF with low Equivalent Series Resistance (ESR) should be used in order to meet these specifications.
- [2] Output voltage towards the card, including ripple.
- [3] Pin I/O has an internal 15 k Ω pull-up resistor to V_{CC} .
- [4] Pin I/OUC has an internal 11 k Ω pull-up resistor to $V_{DD(INTF)}$.

Table 19. Sequencer and clock counter

$V_{DD} = 3.3\text{ V}$; $V_{DD(INTF)} = 1.5\text{ V}$; $f_{CLKIN} = 10\text{ MHz}$; $GND = 0\text{ V}$; $T_{amb} = 25\text{ }^{\circ}\text{C}$; unless otherwise specified.

Symbol	Parameter	Conditions	Min	Typ	Max	Unit
t_{act}	activation time	total sequence	-	-	135	μs
t_{deact}	deactivation time	total sequence	60	80	100	μs

Table 20. Interface signals to host controller

$V_{DD} = 3.3\text{ V}$; $V_{DD(INTF)} = 1.5\text{ V}$; $f_{CLKIN} = 10\text{ MHz}$; $GND = 0\text{ V}$; $T_{amb} = 25\text{ }^{\circ}\text{C}$; unless otherwise specified.

Symbol	Parameter	Conditions	Min	Typ	Max	Unit
Data line: pin I/OUC[1]						
V_{OL}	LOW-level output voltage	$I_{OL} = 1\text{ mA}$	0	-	0.3	V
V_{OH}	HIGH-level output voltage	no DC load	$0.9V_{DD(INTF)}$	-	$V_{DD(INTF)} + 0.2$	V
		$I_{OH} < -10\text{ }\mu\text{A}$	$0.75V_{DD(INTF)}$	-	$V_{DD(INTF)} + 0.2$	V
V_{IL}	LOW-level input voltage		-0.3	-	$0.25V_{DD(INTF)}$	V
V_{IH}	HIGH-level input voltage		$0.7V_{DD(INTF)}$	-	$V_{DD(INTF)} + 0.3$	V
I_{IL}	LOW-level input current	$V_{IL} = 0\text{ V}$	-	-	600	μA
I_{LIH}	HIGH-level input leakage current	$V_{IH} = V_{DD(INTF)}$	-	-	10	μA

Table 20. Interface signals to host controller ...continued

$V_{DD} = 3.3\text{ V}$; $V_{DD(INTF)} = 1.5\text{ V}$; $f_{CLKIN} = 10\text{ MHz}$; $GND = 0\text{ V}$; $T_{amb} = 25\text{ °C}$; unless otherwise specified.

Symbol	Parameter	Conditions	Min	Typ	Max	Unit
t_r	rise time	input; from $V_{IL(max)}$ to $V_{IH(min)}$	-	-	1	μs
t_{TLH}	clock rise time	output transition time; from 10 % to 90 % of $V_{DD(INTF)}$; $C_L < 30\text{ pF}$	-	-	0.1	μs
$R_{pu(int)}$	internal pull-up resistance	between pin I/OUC and pin V_{DDI}	[1] 11	15	19	$\text{k}\Omega$
Clock input: pin CLKIN						
f_{CLKIN}	frequency on pin CLKIN		0	-	25	MHz
V_{IL}	LOW-level input voltage	$V_{DD(INTF)} > 2\text{ V}$	0	-	$0.3V_{DD(INTF)}$	V
		$1.5\text{ V} < V_{DD(INTF)} < 2\text{ V}$	0	-	$0.15V_{DD(INTF)}$	V
V_{IH}	HIGH-level input voltage	$V_{DD(INTF)} > 2\text{ V}$	$0.7V_{DD(INTF)}$	-	$V_{DD(INTF)} + 0.3$	V
		$1.5\text{ V} < V_{DD(INTF)} < 2\text{ V}$	$0.85V_{DD(INTF)}$	-	$V_{DD(INTF)} + 0.3$	ns
t_r	rise time		-	-	$0.1 / f_{CLKIN}$	ns
t_f	fall time		-	-	$0.1 / f_{CLKIN}$	ns
Logic inputs: pins SAD0, SPRES and SDWN						
V_{IL}	LOW-level input voltage		-0.3	-	$0.3V_{DD(INTF)}$	V
V_{IH}	HIGH-level input voltage		$0.7V_{DD}$	-	$V_{DD(INTF)} + 0.3$	V
I_{LIL}	LOW-level input leakage current		-	-	± 1	μA
I_{LIH}	HIGH-level input leakage current		-	-	± 1	μA
C_i	input capacitance		-	-	10	pF
Interrupt line: pin INT; open-drain active-LOW output						
V_{OL}	LOW-level output voltage	$I_o = 2\text{ mA}$	-	-	0.3	V
I_{LH}	HIGH-level leakage current		-	-	10	μA
Serial data input/output: pin SDA; open-drain						
V_{IL}	LOW-level input voltage		-0.3	-	$0.3V_{DD}$	V
V_{IH}	HIGH-level input voltage		$0.7V_{DD}$	-	6.5	V
V_{OL1}	LOW-level output voltage	$I_{OL} = 3\text{ mA}$	-	-	0.3	V
I_{LH}	HIGH-level leakage current	input or output	-	-	1	μA
I_{LL}	LOW-level leakage current	depends on the pull-up resistance; input or output	-	-	1	μA
Serial clock input: pin SCL						
V_{IL}	LOW-level input voltage		-0.3	-	$0.3V_{DD}$	V
V_{IH}	HIGH-level input voltage		$0.7V_{DD}$	-	6.5	V
I_{LIH}	HIGH-level input leakage current		-	-	1	μA
I_{IL}	LOW-level input current	depends on the pull-up resistance	-	-	1	μA

Table 20. Interface signals to host controller ...continued

$V_{DD} = 3.3\text{ V}$; $V_{DD(INTF)} = 1.5\text{ V}$; $f_{CLKIN} = 10\text{ MHz}$; $GND = 0\text{ V}$; $T_{amb} = 25\text{ °C}$; unless otherwise specified.

Symbol	Parameter	Conditions	Min	Typ	Max	Unit
I²C-bus timing; see Figure 7						
f _{SCL}	SCL clock frequency		0	-	400	kHz
t _{BUF}	bus free time between a STOP and START condition		1.3	-	-	μs
t _{HD;STA}	hold time (repeated) START condition	hold time after which first clock pulse is generated	0.6	-	-	μs
t _{LOW}	LOW period of the SCL clock		1.3	-	-	μs
t _{HIGH}	HIGH period of the SCL clock		0.6	-	-	μs
t _{SU;STA}	set-up time for a repeated START condition		0.6	-	-	μs
t _{HD;DAT}	data hold time		[2] 0	-	-	ns
t _{SU;DAT}	data set-up time		100	-	-	ns
t _r	rise time of both SDA and SCL signals		-	-	300	ns
t _f	fall time of both SDA and SCL signals		-	-	300	ns
t _{SU;STO}	set-up time for STOP condition		0.6	-	-	μs

[1] Pin I/OUC has an internal 11 kΩ pull-up resistor to V_{DD(INTF)}.

[2] The hold time required (not greater than 300 ns) to bridge the undefined region of the falling edge of SCL must be internally provided by a transmitter.

Table 21. Protection and limitations

$V_{DD} = 3.3\text{ V}$; $V_{DD(INTF)} = 1.5\text{ V}$; $f_{CLKIN} = 10\text{ MHz}$; $GND = 0\text{ V}$; $T_{amb} = 25\text{ °C}$; unless otherwise specified.

Symbol	Parameter	Conditions	Min	Typ	Max	Unit
T _{amb}	ambient temperature		-40	-	+85	°C
T _{sd}	shutdown temperature	at die	-	150	-	°C
I _{Ilim}	input current limit	on pin I/O	[1] -15	-	+15	mA
I _{Olim}	output current limit	on pin I/O	[1] -15	-	+15	mA
		on pin CLK	-70	-	+70	mA
		shutdown current; on pin RST	-20	-	+20	mA
		shutdown current; on pin V _{CC}	-	-90	-	mA

[1] Pin I/O has an internal 15 kΩ pull-up resistor to V_{CC}.

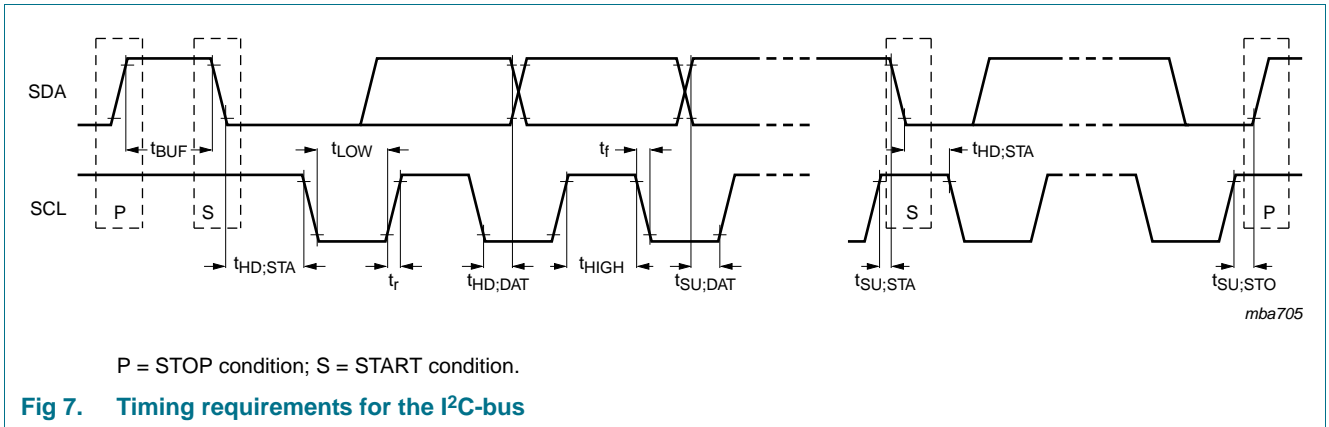

12. Application information

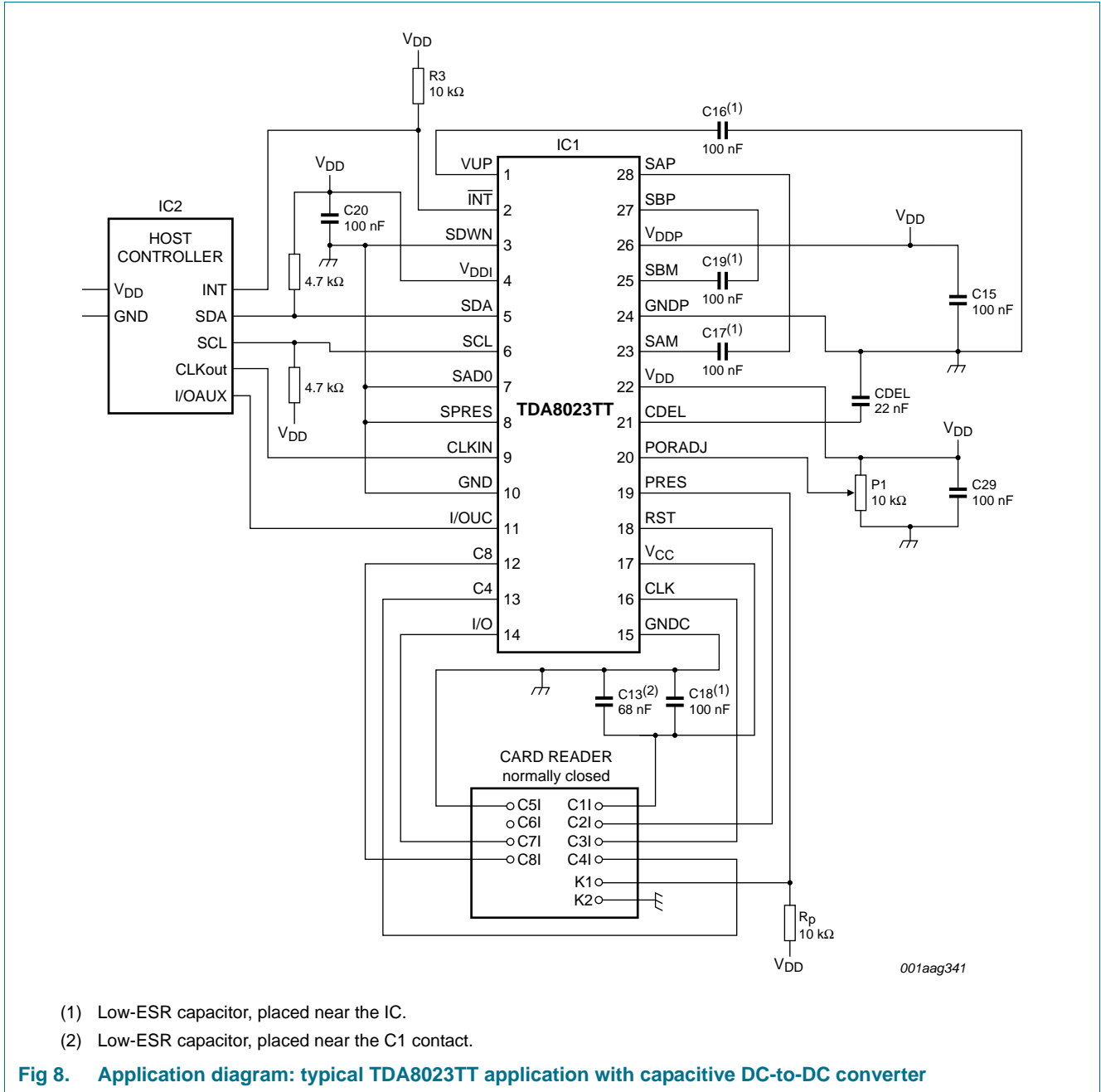

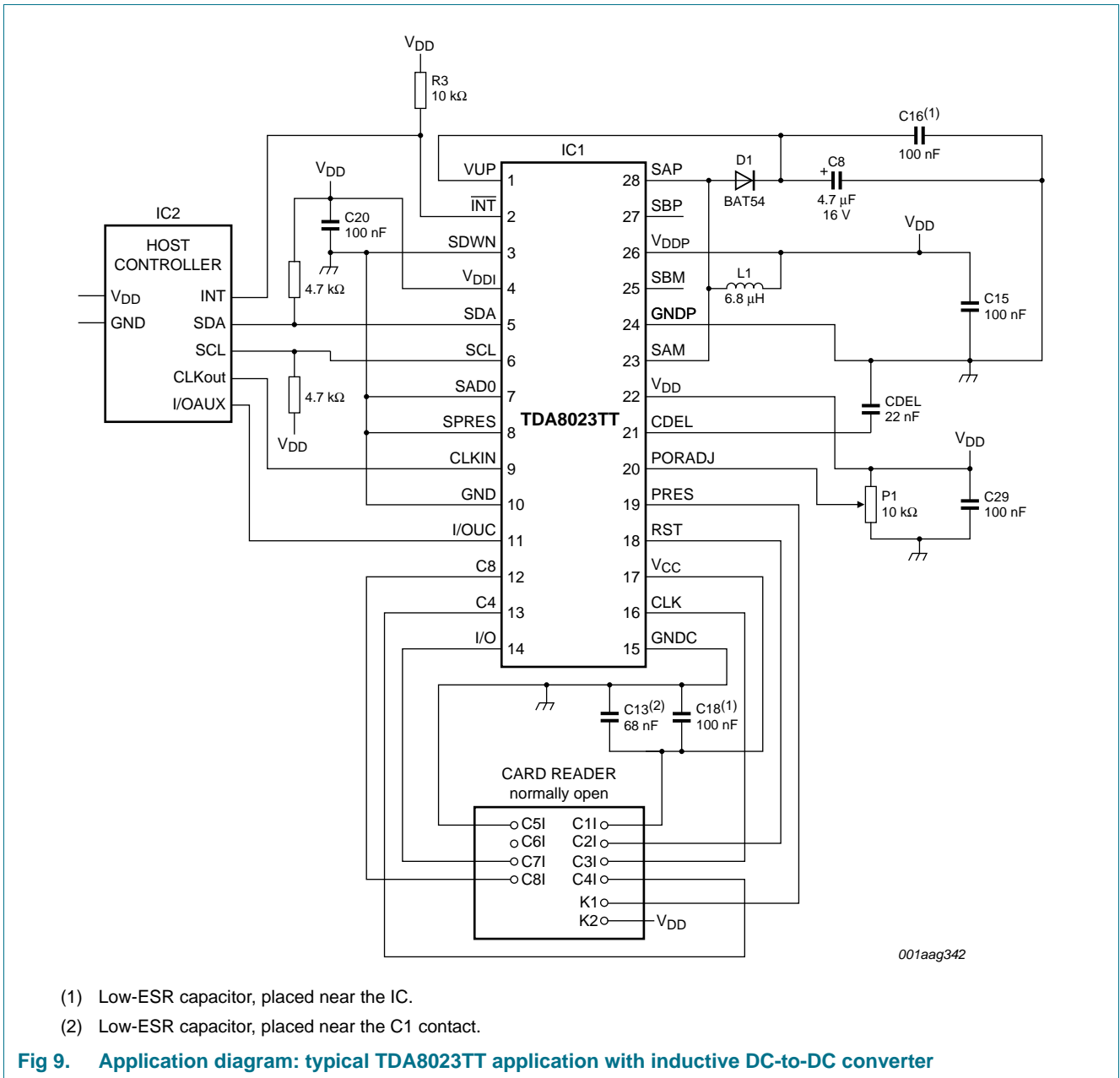

13. Package outline

TSSOP28: plastic thin shrink small outline package; 28 leads; body width 4.4 mm

SOT361-1

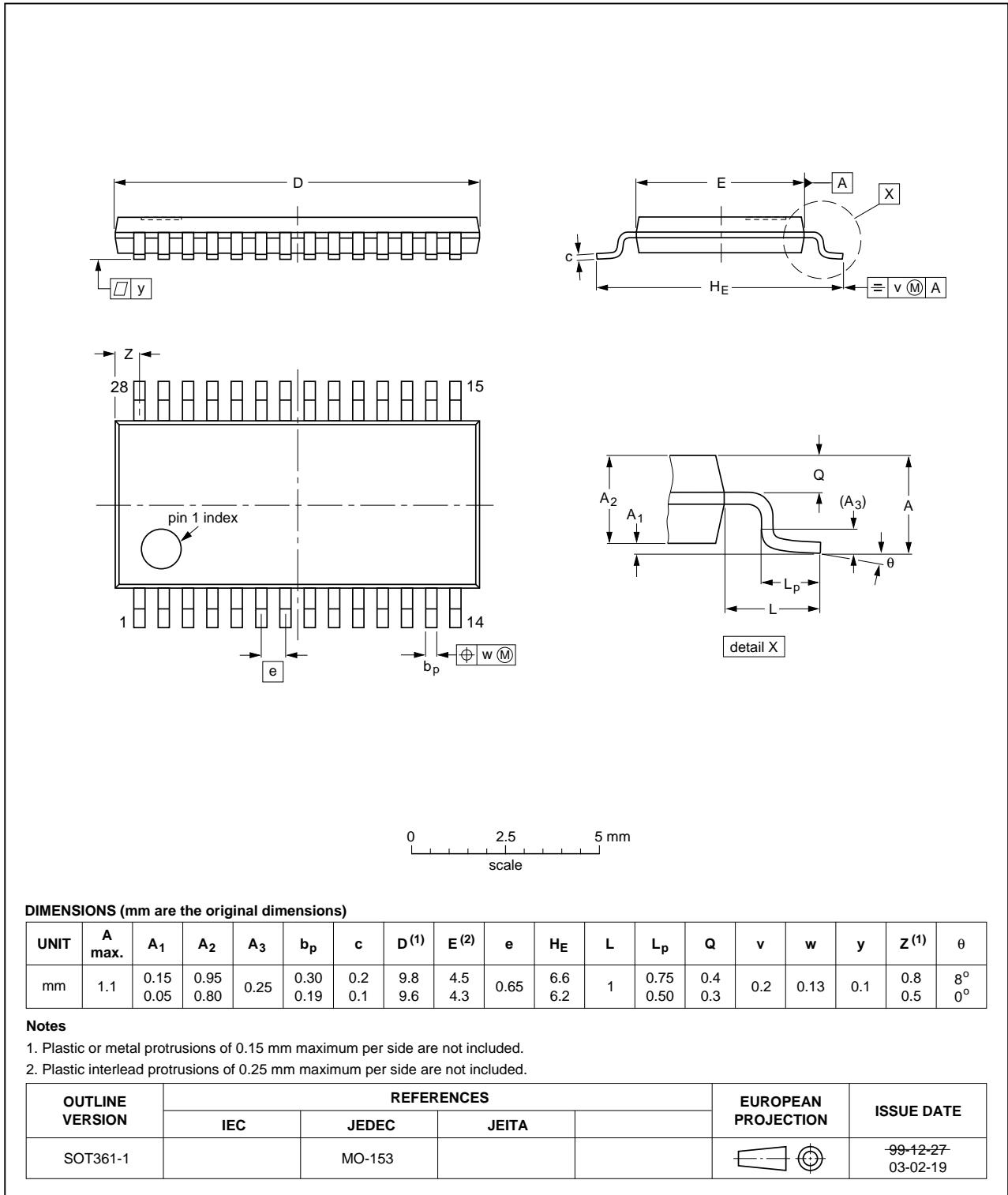

Fig 10. Package outline SOT361-1 (TSSOP28)

14. Soldering of SMD packages

This text provides a very brief insight into a complex technology. A more in-depth account of soldering ICs can be found in Application Note *AN10365 "Surface mount reflow soldering description"*.

14.1 Introduction to soldering

Soldering is one of the most common methods through which packages are attached to Printed Circuit Boards (PCBs), to form electrical circuits. The soldered joint provides both the mechanical and the electrical connection. There is no single soldering method that is ideal for all IC packages. Wave soldering is often preferred when through-hole and Surface Mount Devices (SMDs) are mixed on one printed wiring board; however, it is not suitable for fine pitch SMDs. Reflow soldering is ideal for the small pitches and high densities that come with increased miniaturization.

14.2 Wave and reflow soldering

Wave soldering is a joining technology in which the joints are made by solder coming from a standing wave of liquid solder. The wave soldering process is suitable for the following:

- Through-hole components
- Leaded or leadless SMDs, which are glued to the surface of the printed circuit board

Not all SMDs can be wave soldered. Packages with solder balls, and some leadless packages which have solder lands underneath the body, cannot be wave soldered. Also, leaded SMDs with leads having a pitch smaller than ~0.6 mm cannot be wave soldered, due to an increased probability of bridging.

The reflow soldering process involves applying solder paste to a board, followed by component placement and exposure to a temperature profile. Leaded packages, packages with solder balls, and leadless packages are all reflow solderable.

Key characteristics in both wave and reflow soldering are:

- Board specifications, including the board finish, solder masks and vias
- Package footprints, including solder thieves and orientation
- The moisture sensitivity level of the packages
- Package placement
- Inspection and repair
- Lead-free soldering versus SnPb soldering

14.3 Wave soldering

Key characteristics in wave soldering are:

- Process issues, such as application of adhesive and flux, clinching of leads, board transport, the solder wave parameters, and the time during which components are exposed to the wave
- Solder bath specifications, including temperature and impurities

14.4 Reflow soldering

Key characteristics in reflow soldering are:

- Lead-free versus SnPb soldering; note that a lead-free reflow process usually leads to higher minimum peak temperatures (see [Figure 11](#)) than a SnPb process, thus reducing the process window
- Solder paste printing issues including smearing, release, and adjusting the process window for a mix of large and small components on one board
- Reflow temperature profile; this profile includes preheat, reflow (in which the board is heated to the peak temperature) and cooling down. It is imperative that the peak temperature is high enough for the solder to make reliable solder joints (a solder paste characteristic). In addition, the peak temperature must be low enough that the packages and/or boards are not damaged. The peak temperature of the package depends on package thickness and volume and is classified in accordance with [Table 22](#) and [23](#)

Table 22. SnPb eutectic process (from J-STD-020D)

Package thickness (mm)	Package reflow temperature (°C)	
	Volume (mm ³)	
	< 350	≥ 350
< 2.5	235	220
≥ 2.5	220	220

Table 23. Lead-free process (from J-STD-020D)

Package thickness (mm)	Package reflow temperature (°C)		
	Volume (mm ³)		
	< 350	350 to 2000	> 2000
< 1.6	260	260	260
1.6 to 2.5	260	250	245
> 2.5	250	245	245

Moisture sensitivity precautions, as indicated on the packing, must be respected at all times.

Studies have shown that small packages reach higher temperatures during reflow soldering, see [Figure 11](#).

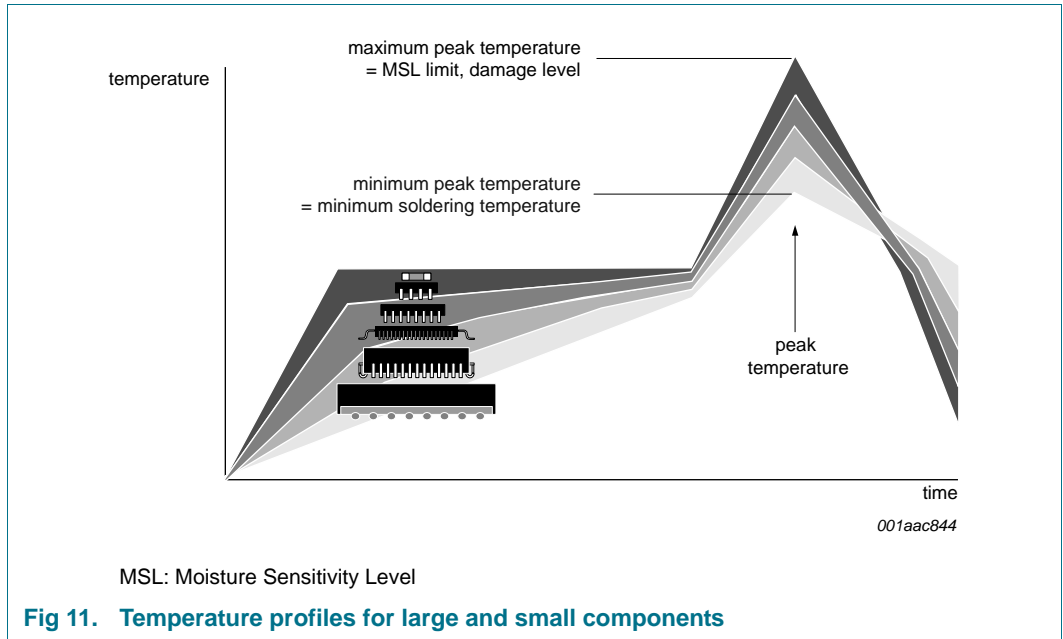

For further information on temperature profiles, refer to Application Note AN10365 “Surface mount reflow soldering description”.

15. Revision history

Table 24. Revision history

Document ID	Release date	Data sheet status	Change notice	Supersedes
TDA8023 v.2.0	20160624	Product data sheet	-	TDA8023_1
Modifications:	<ul style="list-style-type: none">• Table 1 “Quick reference data”: V_{CC} at 1.8 V updated• Table 18 “Card drivers”: V_{IL} V_{OL} V_{OH} updated according to EMVCo 4.3.• The format of this data sheet has been redesigned to comply with the new identity guidelines of NXP Semiconductors.• Legal texts have been adapted to the new company name where appropriate.			
TDA8023_1	20070716	Product data sheet	-	-

16. Legal information

16.1 Data sheet status

Document status ^{[1][2]}	Product status ^[3]	Definition
Objective [short] data sheet	Development	This document contains data from the objective specification for product development.
Preliminary [short] data sheet	Qualification	This document contains data from the preliminary specification.
Product [short] data sheet	Production	This document contains the product specification.

[1] Please consult the most recently issued document before initiating or completing a design.

[2] The term 'short data sheet' is explained in section "Definitions".

[3] The product status of device(s) described in this document may have changed since this document was published and may differ in case of multiple devices. The latest product status information is available on the Internet at URL <http://www.nxp.com>.

16.2 Definitions

Draft — The document is a draft version only. The content is still under internal review and subject to formal approval, which may result in modifications or additions. NXP Semiconductors does not give any representations or warranties as to the accuracy or completeness of information included herein and shall have no liability for the consequences of use of such information.

Short data sheet — A short data sheet is an extract from a full data sheet with the same product type number(s) and title. A short data sheet is intended for quick reference only and should not be relied upon to contain detailed and full information. For detailed and full information see the relevant full data sheet, which is available on request via the local NXP Semiconductors sales office. In case of any inconsistency or conflict with the short data sheet, the full data sheet shall prevail.

Product specification — The information and data provided in a Product data sheet shall define the specification of the product as agreed between NXP Semiconductors and its customer, unless NXP Semiconductors and customer have explicitly agreed otherwise in writing. In no event however, shall an agreement be valid in which the NXP Semiconductors product is deemed to offer functions and qualities beyond those described in the Product data sheet.

16.3 Disclaimers

Limited warranty and liability — Information in this document is believed to be accurate and reliable. However, NXP Semiconductors does not give any representations or warranties, expressed or implied, as to the accuracy or completeness of such information and shall have no liability for the consequences of use of such information. NXP Semiconductors takes no responsibility for the content in this document if provided by an information source outside of NXP Semiconductors.

In no event shall NXP Semiconductors be liable for any indirect, incidental, punitive, special or consequential damages (including - without limitation - lost profits, lost savings, business interruption, costs related to the removal or replacement of any products or rework charges) whether or not such damages are based on tort (including negligence), warranty, breach of contract or any other legal theory.

Notwithstanding any damages that customer might incur for any reason whatsoever, NXP Semiconductors' aggregate and cumulative liability towards customer for the products described herein shall be limited in accordance with the *Terms and conditions of commercial sale* of NXP Semiconductors.

Right to make changes — NXP Semiconductors reserves the right to make changes to information published in this document, including without limitation specifications and product descriptions, at any time and without notice. This document supersedes and replaces all information supplied prior to the publication hereof.

Suitability for use — NXP Semiconductors products are not designed, authorized or warranted to be suitable for use in life support, life-critical or safety-critical systems or equipment, nor in applications where failure or malfunction of an NXP Semiconductors product can reasonably be expected to result in personal injury, death or severe property or environmental damage. NXP Semiconductors and its suppliers accept no liability for inclusion and/or use of NXP Semiconductors products in such equipment or applications and therefore such inclusion and/or use is at the customer's own risk.

Applications — Applications that are described herein for any of these products are for illustrative purposes only. NXP Semiconductors makes no representation or warranty that such applications will be suitable for the specified use without further testing or modification.

Customers are responsible for the design and operation of their applications and products using NXP Semiconductors products, and NXP Semiconductors accepts no liability for any assistance with applications or customer product design. It is customer's sole responsibility to determine whether the NXP Semiconductors product is suitable and fit for the customer's applications and products planned, as well as for the planned application and use of customer's third party customer(s). Customers should provide appropriate design and operating safeguards to minimize the risks associated with their applications and products.

NXP Semiconductors does not accept any liability related to any default, damage, costs or problem which is based on any weakness or default in the customer's applications or products, or the application or use by customer's third party customer(s). Customer is responsible for doing all necessary testing for the customer's applications and products using NXP Semiconductors products in order to avoid a default of the applications and the products or of the application or use by customer's third party customer(s). NXP does not accept any liability in this respect.

Limiting values — Stress above one or more limiting values (as defined in the Absolute Maximum Ratings System of IEC 60134) will cause permanent damage to the device. Limiting values are stress ratings only and (proper) operation of the device at these or any other conditions above those given in the Recommended operating conditions section (if present) or the Characteristics sections of this document is not warranted. Constant or repeated exposure to limiting values will permanently and irreversibly affect the quality and reliability of the device.

Terms and conditions of commercial sale — NXP Semiconductors products are sold subject to the general terms and conditions of commercial sale, as published at <http://www.nxp.com/profile/terms>, unless otherwise agreed in a valid written individual agreement. In case an individual agreement is concluded only the terms and conditions of the respective agreement shall apply. NXP Semiconductors hereby expressly objects to applying the customer's general terms and conditions with regard to the purchase of NXP Semiconductors products by customer.

No offer to sell or license — Nothing in this document may be interpreted or construed as an offer to sell products that is open for acceptance or the grant, conveyance or implication of any license under any copyrights, patents or other industrial or intellectual property rights.

Export control — This document as well as the item(s) described herein may be subject to export control regulations. Export might require a prior authorization from competent authorities.

Non-automotive qualified products — Unless this data sheet expressly states that this specific NXP Semiconductors product is automotive qualified, the product is not suitable for automotive use. It is neither qualified nor tested in accordance with automotive testing or application requirements. NXP Semiconductors accepts no liability for inclusion and/or use of non-automotive qualified products in automotive equipment or applications.

In the event that customer uses the product for design-in and use in automotive applications to automotive specifications and standards, customer (a) shall use the product without NXP Semiconductors' warranty of the product for such automotive applications, use and specifications, and (b) whenever customer uses the product for automotive applications beyond NXP Semiconductors' specifications such use shall be solely at customer's

own risk, and (c) customer fully indemnifies NXP Semiconductors for any liability, damages or failed product claims resulting from customer design and use of the product for automotive applications beyond NXP Semiconductors' standard warranty and NXP Semiconductors' product specifications.

Translations — A non-English (translated) version of a document is for reference only. The English version shall prevail in case of any discrepancy between the translated and English versions.

16.4 Trademarks

Notice: All referenced brands, product names, service names and trademarks are the property of their respective owners.

I²C-bus — logo is a trademark of NXP B.V.

17. Contact information

For more information, please visit: <http://www.nxp.com>

For sales office addresses, please send an email to: salesaddresses@nxp.com

18. Contents

1	General description	1	16.4	Trademarks	32
2	Features and benefits	1	17	Contact information	32
3	Applications	2	18	Contents	33
4	Quick reference data	2			
5	Ordering information	3			
6	Block diagram	3			
7	Pinning information	4			
7.1	Pinning	4			
7.2	Pin description	5			
8	Functional description	6			
8.1	Power supplies	6			
8.2	Voltage supervisor	6			
8.2.1	Without external divider on pin PORADJ	6			
8.2.2	With external divider on pin PORADJ	7			
8.2.3	External capacitor on pin CDEL	7			
8.2.4	Shutdown mode	8			
8.3	I ² C-bus	8			
8.3.1	I ² C-bus protocol	8			
8.3.2	Bus conditions	8			
8.3.3	Data transfer	8			
8.3.4	Device addressing	9			
8.3.5	Registers	10			
8.4	DC-to-DC converter	12			
8.4.1	Capacitive configuration	12			
8.4.2	Inductive configuration	13			
8.5	V _{CC} buffer	13			
8.6	Sequencer and clock counter	13			
8.6.1	Activation sequence	13			
8.6.2	Deactivation sequence	15			
8.7	Protection	15			
9	Limiting values	16			
10	Thermal characteristics	16			
11	Characteristics	17			
12	Application information	24			
13	Package outline	26			
14	Soldering of SMD packages	27			
14.1	Introduction to soldering	27			
14.2	Wave and reflow soldering	27			
14.3	Wave soldering	27			
14.4	Reflow soldering	28			
15	Revision history	30			
16	Legal information	31			
16.1	Data sheet status	31			
16.2	Definitions	31			
16.3	Disclaimers	31			

Please be aware that important notices concerning this document and the product(s) described herein, have been included in section 'Legal information'.

© NXP Semiconductors N.V. 2016.

All rights reserved.

For more information, please visit: <http://www.nxp.com>

For sales office addresses, please send an email to: salesaddresses@nxp.com

Date of release: 24 June 2016

Document identifier: TDA8023



Компания «ЭлектроПласт» предлагает заключение долгосрочных отношений при поставках импортных электронных компонентов на взаимовыгодных условиях!

Наши преимущества:

- Оперативные поставки широкого спектра электронных компонентов отечественного и импортного производства напрямую от производителей и с крупнейших мировых складов;
- Поставка более 17-ти миллионов наименований электронных компонентов;
- Поставка сложных, дефицитных, либо снятых с производства позиций;
- Оперативные сроки поставки под заказ (от 5 рабочих дней);
- Экспресс доставка в любую точку России;
- Техническая поддержка проекта, помощь в подборе аналогов, поставка прототипов;
- Система менеджмента качества сертифицирована по Международному стандарту ISO 9001;
- Лицензия ФСБ на осуществление работ с использованием сведений, составляющих государственную тайну;
- Поставка специализированных компонентов (Xilinx, Altera, Analog Devices, Intersil, Interpoint, Microsemi, Aeroflex, Peregrine, Syfer, Eurofarad, Texas Instrument, Miteq, Cobham, E2V, MA-COM, Hittite, Mini-Circuits, General Dynamics и др.);

Помимо этого, одним из направлений компании «ЭлектроПласт» является направление «Источники питания». Мы предлагаем Вам помощь Конструкторского отдела:

- Подбор оптимального решения, техническое обоснование при выборе компонента;
- Подбор аналогов;
- Консультации по применению компонента;
- Поставка образцов и прототипов;
- Техническая поддержка проекта;
- Защита от снятия компонента с производства.



Как с нами связаться

Телефон: 8 (812) 309 58 32 (многоканальный)

Факс: 8 (812) 320-02-42

Электронная почта: org@eplast1.ru

Адрес: 198099, г. Санкт-Петербург, ул. Калинина, дом 2, корпус 4, литера А.