

HDSP-B0xE

18:88 and 88:88 0.56" Four Digit GaP HER
Seven Segment Display



Data Sheet



Description

The 18:88 and 88:88 0.56" Four Digit Seven Segment Displays have surface painted in neutral gray for enhanced on/off contrast. All devices are available in either common anode or common cathode configuration with untinted segments.

Features

- Excellent appearance
- Evenly illuminated segments
- Gray face for optimum on/off contrast
- Choice of colors: HER
- Choice of character size: 0.56 inch

Package Dimensions

88:88 0.56" Four Digit Display

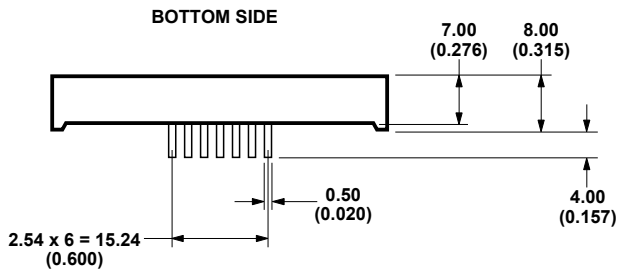
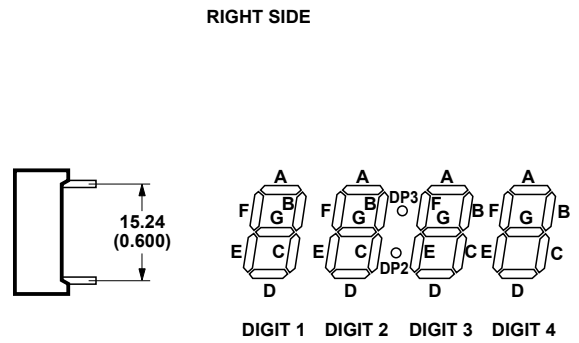
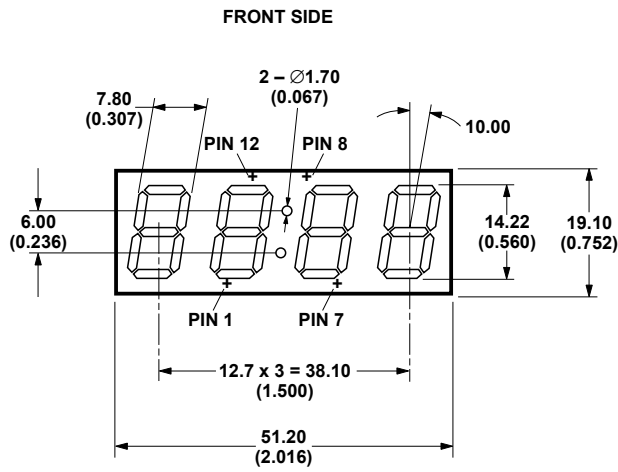

NOTE:
 ALL DIMENSIONS ARE IN MILLIMETERS (INCHES).
 UNLESS OTHERWISE STATED, TOLERANCES ARE ± 0.25 mm.

Package Dimensions

18:88 0.56" Four Digit Display

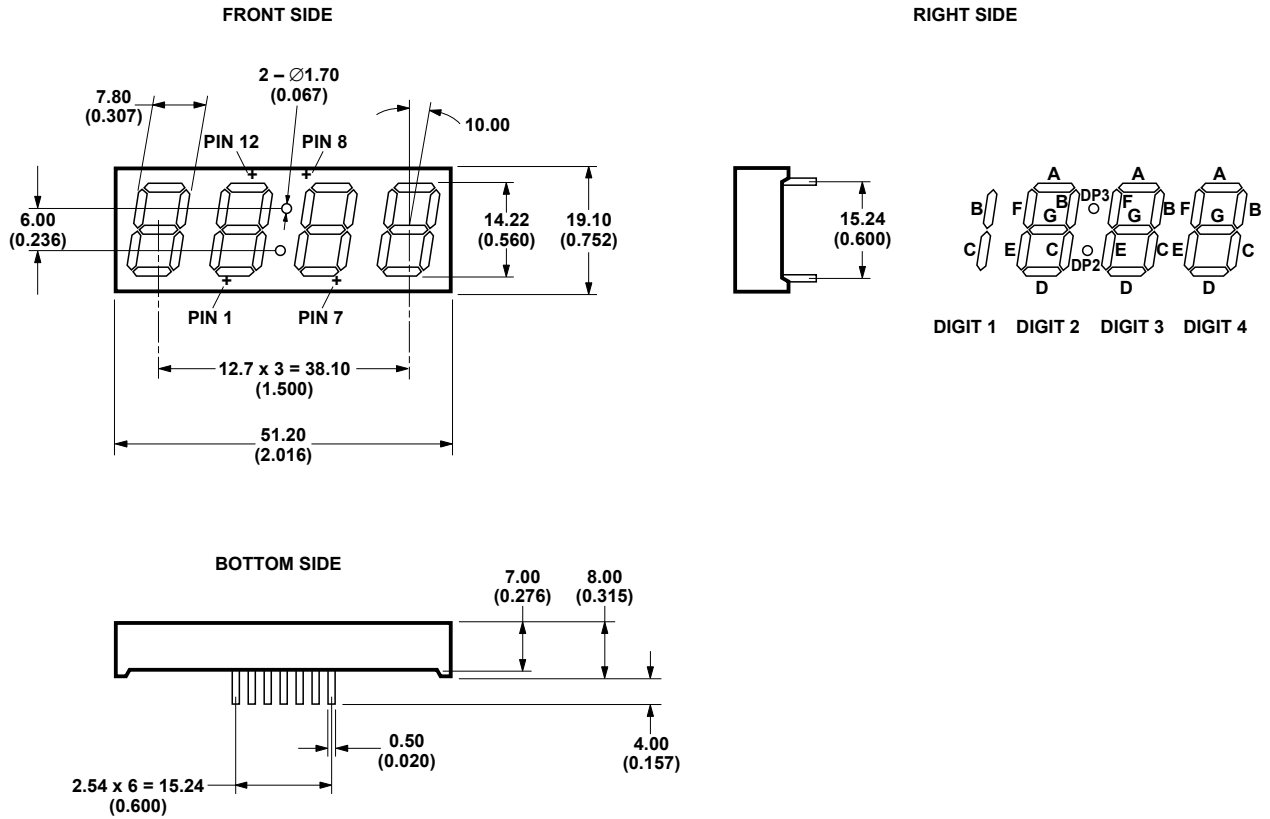

NOTE:
 ALL DIMENSIONS ARE IN MILLIMETERS (INCHES).
 UNLESS OTHERWISE STATED, TOLERANCES ARE ± 0.25 mm.

Pin Configuration

Pin	Function	
	HDSP-B01E/B03E	HDSP-B02E/B04E
1	Anode E	Cathode E
2	Anode D	Cathode D
3	Anode DP	Cathode DP
4	Anode C	Cathode C
5	Anode G	Cathode G
6	Digit 4 Common Cathode	Digit 4 Common Anode
7	Anode B	Cathode B
8	Digit 3 Common Cathode	Digit 3 Common Anode
9	Digit 2 Common Cathode	Digit 2 Common Anode
10	Anode F	Cathode F
11	Anode A	Cathode A
12	Digit 1 Common Cathode	Digit 1 Common Anode

Internal Circuit Diagram

HDSP-B01E (Common Cathode)

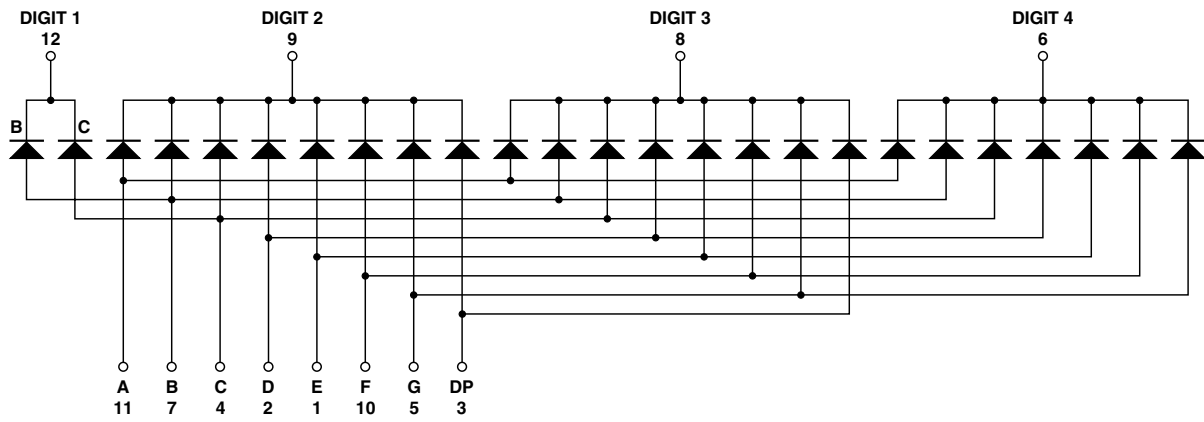

HDSP-B02E (Common Anode)

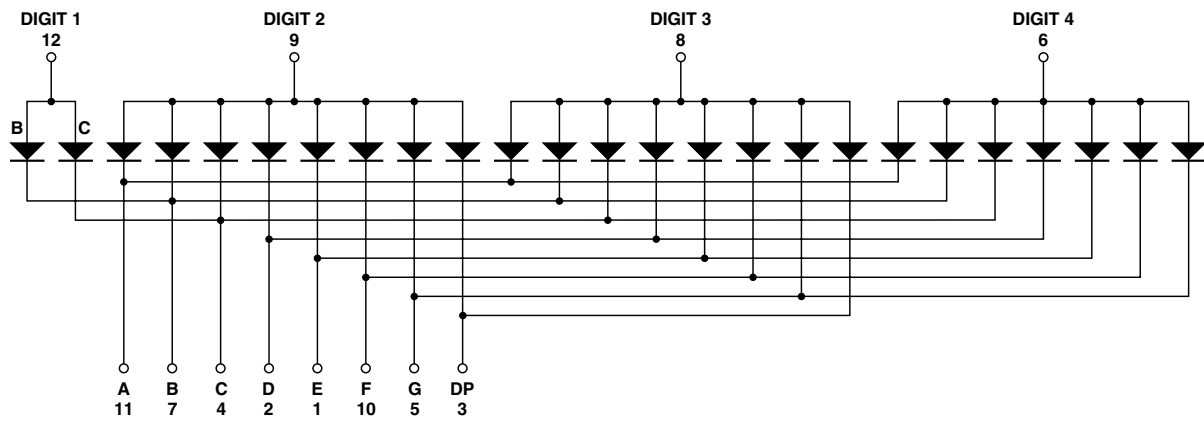

Internal Circuit Diagram

HDSP-B03E (Common Cathode)

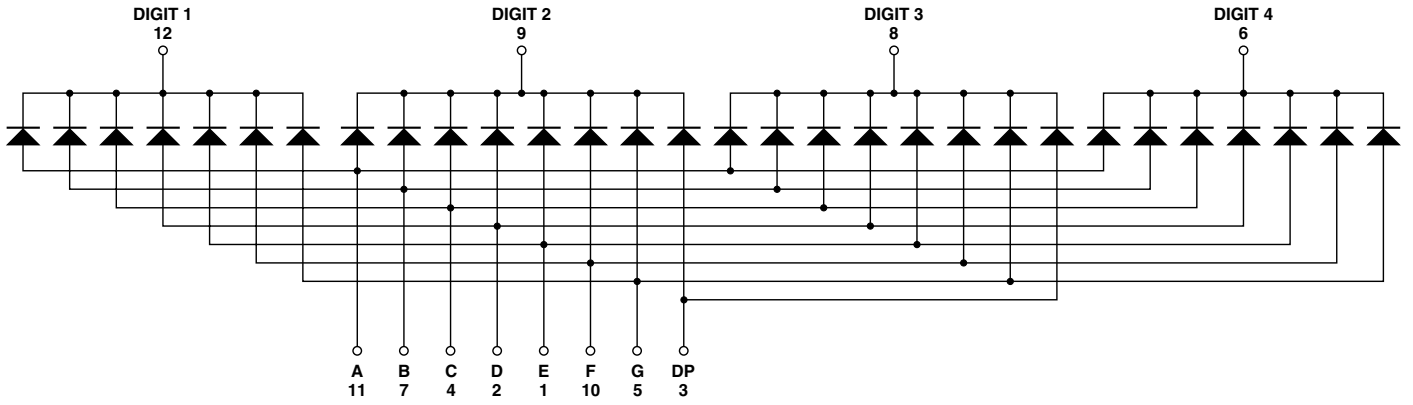

HDSP-B04E (Common Anode)

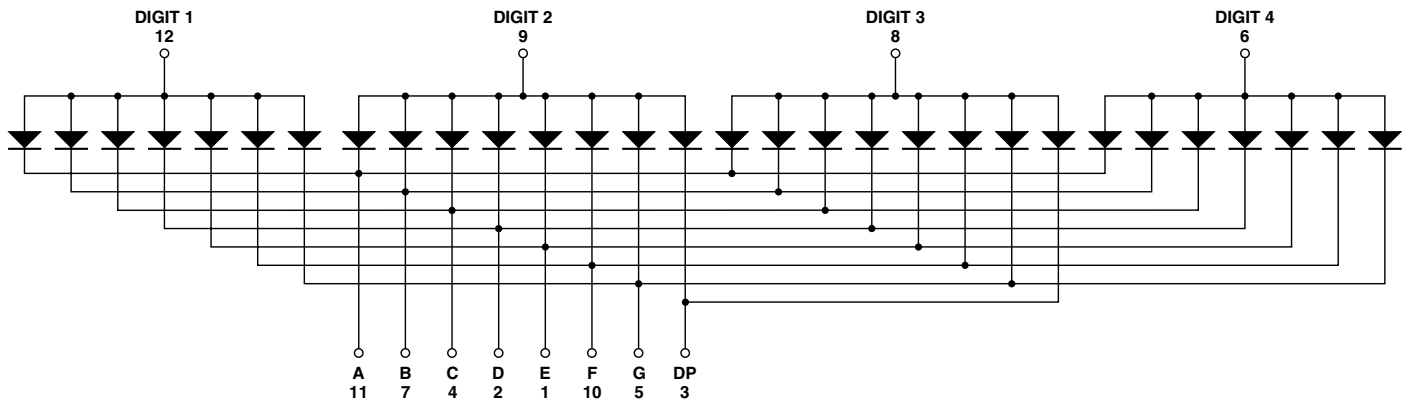

Devices

HDSP-	Description
B01E	88:88 0.56" HER 4 Digit, Untinted, Common Cathode, Display 18:88, Gray Color Surface
B02E	88:88 0.56" HER 4 Digit, Untinted, Common Anode, Display 18:88, Gray Color Surface
B03E	88:88 0.56" HER 4 Digit, Untinted, Common Cathode, Display 88:88, Gray Color Surface
B04E	88:88 0.56" HER 4 Digit, Untinted, Common Anode, Display 88:88, Gray Color Surface

Part Numbering System

5082 -X X X X-X X X X X
 HDSP-X X X X-X X X X X

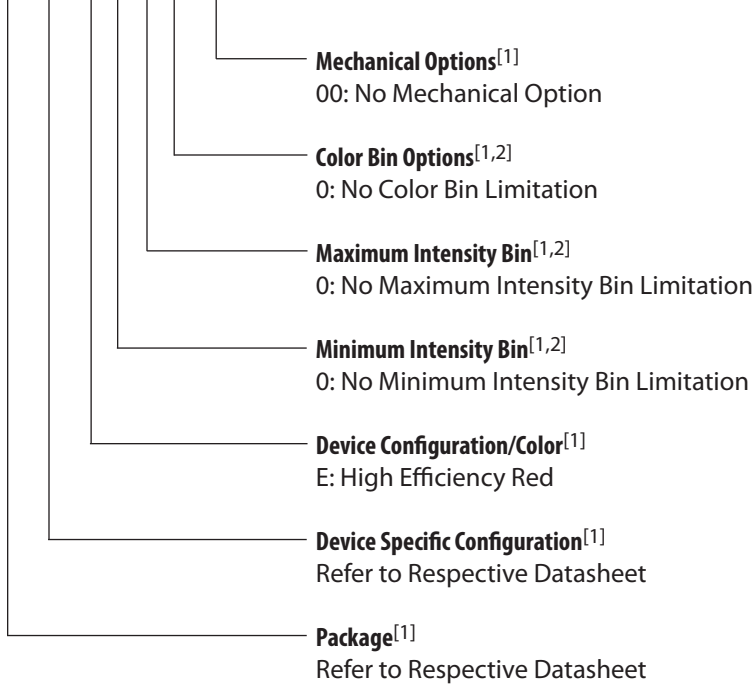

Notes:

1. For codes not listed in the figure above, please refer to the respective datasheet or contact your nearest Avago representative for details.
2. Bin options refer to shippable bins for a part number. Color and Intensity Bins are typically restricted to 1 bin per tube (exceptions may apply). Please refer to respective datasheet for specific bin limit information.

Absolute Maximum Ratings

Description	HER	Units
Average Power per Segment or DP	65	mW
Peak Forward Current per Segment or DP	100	mA
DC Forward Current per Segment or DP	25	mA
Operating Temperature Range	-40 to +105	°C
Storage Temperature Range	-40 to +105	°C
Reverse Voltage per Segment or DP	5	V
Wavesoldering Temperature for 3 seconds 1.59 mm below body	250	°C

Note:

1. Derate above 40°C at 0.33 mA/°C for HER.

Electrical/Optical Characteristics at T_A = 25°C

Device Series	Parameter	Symbol	Min.	Typ.	Max.	Units	Test Conditions
B01E B02E	Luminous Intensity/Segment (Digit Average)	I _V	3200	5500		μcd	I _F = 10 mA
B03E B04E							
	Forward Voltage/Segment or DP	V _F		2.05	2.60	V	I _F = 20 mA
	Peak Wavelength	λ _{PEAK}		632		nm	I _F = 20 mA
	Dominant Wavelength	λ _d		622		nm	I _F = 20 mA
	Luminous Intensity Matching Ratio	I _{V-M}			2:1		I _F = 10 mA
	Reverse Current	I _R			100	μA	V _R = 5 V

Notes:

1. Typical specification for reference only. Do not exceed absolute maximum ratings.
2. The dominant wavelength, λ_d, is derived from the CIE chromaticity diagram and is that single wavelength which defines the color of the device.

Intensity Bin Limits (Tolerance ± 10%)

Rank	Symbol	Condition	Min.	Max.	Unit
L	I _V	I _F = 10 mA	3200	5050	μcd
M	I _V	I _F = 10 mA	5050	8000	μcd

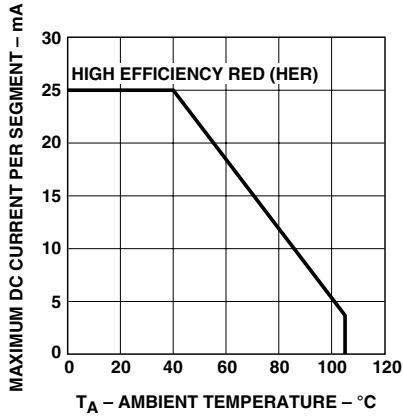

Figure 1. Maximum allowable average or DC current vs. ambient temperature.

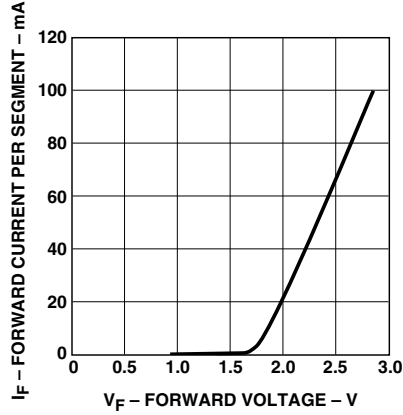

Figure 2. Forward current vs. forward voltage.

Contrast Enhancement

For information on contrast enhancement, please see Application Note 1015.

Soldering/Cleaning

Cleaning agents from the ketone family (acetone, methyl ethyl ketone, etc.) and from the chlorinated hydrocarbon family (methylene chloride, trichloroethylene, carbon tetrachloride, etc.) are not recommended for cleaning LED parts. All these various solvents attack or dissolve the encapsulating epoxies used to form the package of plastic LED parts.

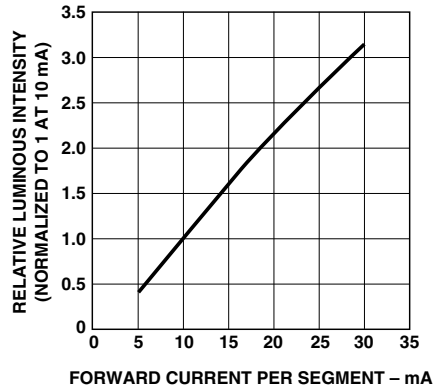

Figure 3. Relative luminous intensity vs. DC forward current.

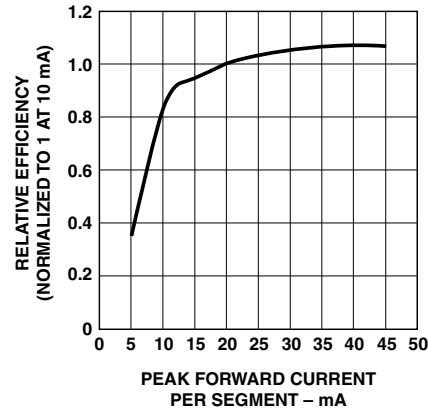

Figure 4. Relative efficiency (luminous intensity per unit current) vs. peak current.

For product information and a complete list of distributors, please go to our website: www.avagotech.com

Avago, Avago Technologies, and the A logo are trademarks of Avago Technologies Limited in the United States and other countries. Data subject to change. Copyright © 2006 Avago Technologies Limited. All rights reserved. Obsoletes 5988-3569EN AV02-0568EN - July 4, 2007

AVAGO
TECHNOLOGIES



Компания «ЭлектроПласт» предлагает заключение долгосрочных отношений при поставках импортных электронных компонентов на взаимовыгодных условиях!

Наши преимущества:

- Оперативные поставки широкого спектра электронных компонентов отечественного и импортного производства напрямую от производителей и с крупнейших мировых складов;
- Поставка более 17-ти миллионов наименований электронных компонентов;
- Поставка сложных, дефицитных, либо снятых с производства позиций;
- Оперативные сроки поставки под заказ (от 5 рабочих дней);
- Экспресс доставка в любую точку России;
- Техническая поддержка проекта, помощь в подборе аналогов, поставка прототипов;
- Система менеджмента качества сертифицирована по Международному стандарту ISO 9001;
- Лицензия ФСБ на осуществление работ с использованием сведений, составляющих государственную тайну;
- Поставка специализированных компонентов (Xilinx, Altera, Analog Devices, Intersil, Interpoint, Microsemi, Aeroflex, Peregrine, Syfer, Eurofarad, Texas Instrument, Miteq, Cobham, E2V, MA-COM, Hittite, Mini-Circuits, General Dynamics и др.);

Помимо этого, одним из направлений компании «ЭлектроПласт» является направление «Источники питания». Мы предлагаем Вам помощь Конструкторского отдела:

- Подбор оптимального решения, техническое обоснование при выборе компонента;
- Подбор аналогов;
- Консультации по применению компонента;
- Поставка образцов и прототипов;
- Техническая поддержка проекта;
- Защита от снятия компонента с производства.



Как с нами связаться

Телефон: 8 (812) 309 58 32 (многоканальный)

Факс: 8 (812) 320-02-42

Электронная почта: org@eplast1.ru

Адрес: 198099, г. Санкт-Петербург, ул. Калинина, дом 2, корпус 4, литера А.