



SANYO Semiconductors

DATA SHEET

An ON Semiconductor Company

Monolithic Digital IC

LB1973JA — Two-channel H-Bridge Driver

Overview

The LB1973JA is a two-channel H-bridge driver that supports for low saturation drive operation. It is optimal for H-bridge drive of stepping motors (AF and zoom) in portable equipment such as camera cell phones.

Features

- Two-channel H-bridge driver
- 2ch simultaneous connection is possible
- Parallel input interface
- 2 phase excitation, 1-2 phase excitation drive are possible
- The range of the operation voltage is wide.(1.8V to 7.5V)
- Built-in thermal protection

Specifications

Absolute Maximum Ratings at $T_a = 25^\circ\text{C}$

Parameter	Symbol	Conditions	Ratings	Unit
Maximum supply voltage	$V_{CC\ max}$		-0.3 to +8.0	V
Output voltage	$V_{OUT\ max}$		$-V_{SF}$ to $V_{CC}+V_{SF}$	V
Input voltage	$V_{IN\ max}$		-0.3 to +8.0	V
Spark killer Di order direction electric	$I_{SF\ max}$		1000	mA
Ground pin source current	I_{GND}	Per channel	1000	mA
Allowable power dissipation	$P_d\ max$	*Mounted on a board	800	mW
Operating temperature	T_{opr}		-20 to +85	$^\circ\text{C}$
Storage temperature	T_{stg}		-40 to +150	$^\circ\text{C}$

* Mounted on a Specified board : 114.3mm×76.1mm×1.6mm, glass epoxy

Caution 1) Absolute maximum ratings represent the value which cannot be exceeded for any length of time.

Caution 2) Even when the device is used within the range of absolute maximum ratings, as a result of continuous usage under high temperature, high current, high voltage, or drastic temperature change, the reliability of the IC may be degraded. Please contact us for the further details.

Allowable Operating Ratings at $T_a = 25^\circ\text{C}$

Parameter	Symbol	Conditions	Ratings	Unit
Supply voltage	V_{CC}		1.8 to 7.5	V
High-level input voltage	V_{IH}	$R_{IN} = 1\text{k}\Omega$	1.3 to 7.5	V
Low-level input voltage	V_{IL}	$R_{IN} = 1\text{k}\Omega$	-0.3 to +0.5	V

■ Any and all SANYO Semiconductor Co.,Ltd. products described or contained herein are, with regard to "standard application", intended for the use as general electronics equipment (home appliances, AV equipment, communication device, office equipment, industrial equipment etc.). The products mentioned herein shall not be intended for use for any "special application" (medical equipment whose purpose is to sustain life, aerospace instrument, nuclear control device, burning appliances, transportation machine, traffic signal system, safety equipment etc.) that shall require extremely high level of reliability and can directly threaten human lives in case of failure or malfunction of the product or may cause harm to human bodies, nor shall they grant any guarantee thereof. If you should intend to use our products for applications outside the standard applications of our customer who is considering such use and/or outside the scope of our intended standard applications, please consult with us prior to the intended use. If there is no consultation or inquiry before the intended use, our customer shall be solely responsible for the use.

■ Specifications of any and all SANYO Semiconductor Co.,Ltd. products described or contained herein stipulate the performance, characteristics, and functions of the described products in the independent state, and are not guarantees of the performance, characteristics, and functions of the described products as mounted in the customer's products or equipment. To verify symptoms and states that cannot be evaluated in an independent device, the customer should always evaluate and test devices mounted in the customer's products or equipment.

SANYO Semiconductor Co., Ltd.

<http://semicon.sanyo.com/en/network>

LB1973JA

Electrical Characteristics at $T_a = 25^\circ\text{C}$, $V_{CC} = 1.9\text{V}$

Parameter	Symbol	Conditions	Ratings			Unit
			min	typ	max	
Source current	I_{CCO1}	$V_{CC} = 1.9\text{V}, \text{IN1 to IN4} = \text{Low level}$		0.01	1	μA
	I_{CCO2}	$V_{CC} = 3\text{V}, \text{IN1 to IN4} = \text{Low level}$		0.01	1	μA
	I_{CC1}	$\text{IN1} = \text{High level}, \text{IN2 to IN4} = \text{Low level}$		18	25	mA
	I_{CC2}	$\text{IN1} = \text{High level}, \text{IN2 to IN4} = \text{Low level}, V_{CC} = 3\text{V}$		19	27.5	mA
Output saturation voltage1 (single connection)	V_{OUT11}	$I_{OUT} = 270\text{mA}, V_{CC} = 1.9\text{V to } 3.6\text{V}, T_a = -20 \text{ to } 85^\circ\text{C}$ $V_{OUT} = \text{Upper Tr and Under Tr}$ $\text{IN1} = \text{High level}, \text{IN2 to IN4} = \text{Low level}$ Supplementation: Standard similar as for IN2 to IN4 = High level		0.2	0.3	V
	V_{OUT12}	$I_{OUT} = 350\text{mA}, V_{CC} = 1.9\text{V to } 3.6\text{V}, T_a = -20 \text{ to } 85^\circ\text{C}$ $V_{OUT} = \text{Upper Tr and Under Tr}$ $\text{IN1} = \text{High level}, \text{IN2 to IN4} = \text{Low level}$ Supplementation: Standard similar as for IN2 to IN4 = High level		0.25	0.4	V
Output saturation voltage2 (parallel connection)	V_{OUT21}	$I_{OUT} = 270\text{mA}, V_{CC} = 1.9\text{V to } 3.6\text{V}, T_a = -20 \text{ to } 85^\circ\text{C}$ $V_{OUT} = \text{Upper Tr and Under Tr}$ $\text{OUT1-3}, \text{OUT2-4 short. IN1 and IN3} = \text{High level}, \text{IN2 and IN4} = \text{Low level}$ Supplementation: Standard similar as for IN2 and IN4 = High level		0.12	0.2	V
	V_{OUT22}	$I_{OUT} = 500\text{mA}, V_{CC} = 1.9\text{V to } 3.6\text{V}, T_a = -20 \text{ to } 85^\circ\text{C}$ $V_{OUT} = \text{Upper Tr and Under Tr}$ $\text{OUT1-3}, \text{OUT2-4 short. IN1 and IN3} = \text{High level}, \text{IN2 and IN4} = \text{Low level}$ Supplementation: Standard similar as for IN2 and IN4 = High level		0.2	0.35	V
Output electric current with the parasitic element	I_{PA}	$V_{IN} = 1.9 \text{ to } 3.6\text{V}, T_a = -20 \text{ to } 85^\circ\text{C} \quad *1$			9	mA
Input current	I_{IN}	$V_{IN} = 1.9\text{V}$		32	70	μA
Thermal shutdown operation temperature	T_{sd}	*2: Design guarantee		140		$^\circ\text{C}$
Temperature hysteresis width	ΔT	*2: Design guarantee		20		$^\circ\text{C}$
Spark killer Diode						
Reverse current	$I_S(\text{leak})$	$V_{CC-OUT} = 8\text{V}, V_{IN} = \text{Low level}$			10	μA
Forward voltage	V_{SF}	$I_{SF} = 400\text{mA}, V_{IN} = \text{Low level}$			1.7	V

*1: Output electric current with the parasitic element I_{PA} : The current value that the off ch(-free) output is pulled at the time of one side ch drive by a parasitic element

*2: Design guarantee value and does not measure

* VSF: The current order direction voltage true in a time

LB1973JA

Package Dimensions

unit : mm (typ)
3178B

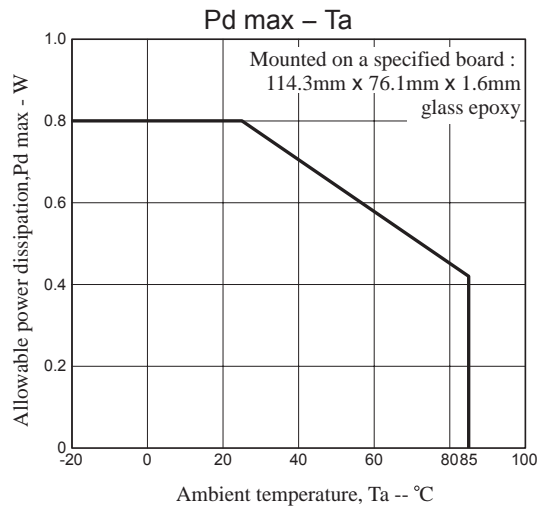
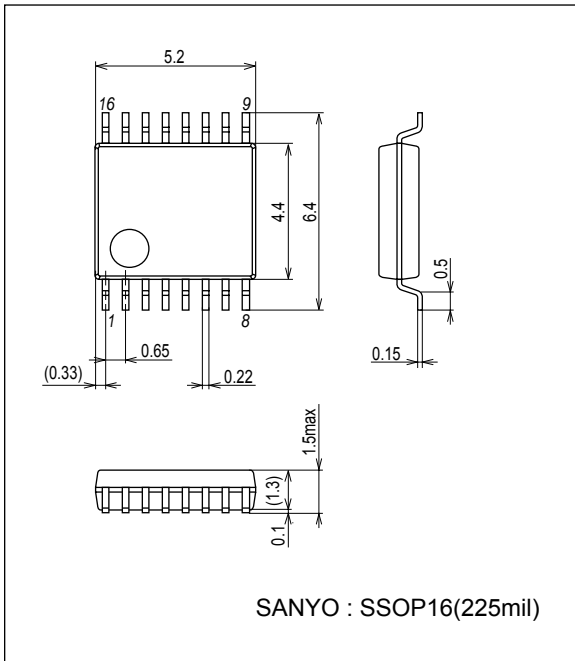

Pin Assignment

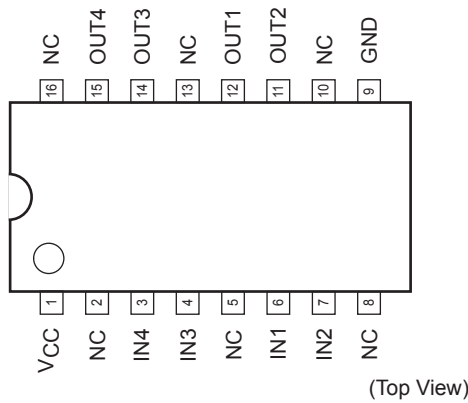

Truth Table

Input				Output				Mode
IN1	IN2	IN3	IN4	OUT1	OUT2	OUT3	OUT4	
Low	Low	Low	Low	Off	Off	Off	Off	Standby mode
High	Low	-	-	High	Low	-	-	Channel 1, forward
Low	High			Low	High			Channel 1, reverse
-	-	High	Low	-	-	High	Low	Channel 2, forward
		Low	High			Low	High	Channel 2, reverse
High	High	-	-	The logic output for the first high-level input is produced.				
-	-	High	High					

Stepping motor control example

(1) Timing chart for 2-phase drive

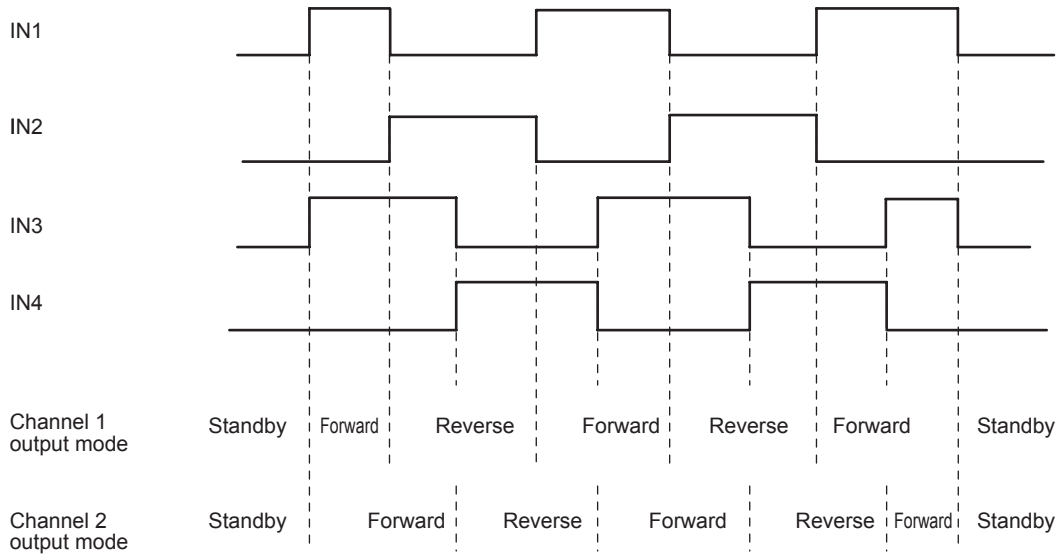

(2) Timing chart for 1-2 phase drive

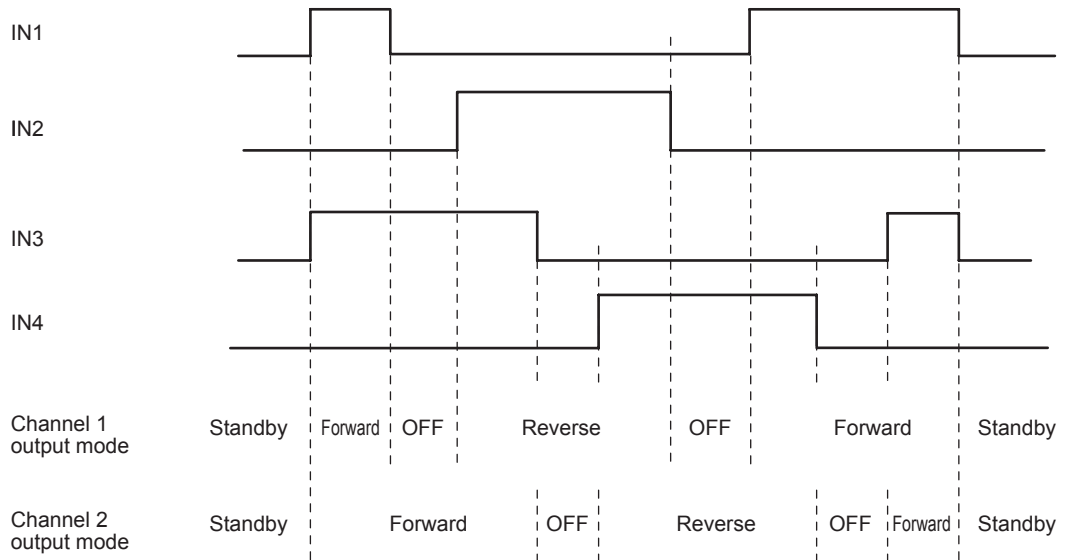

Block Diagram

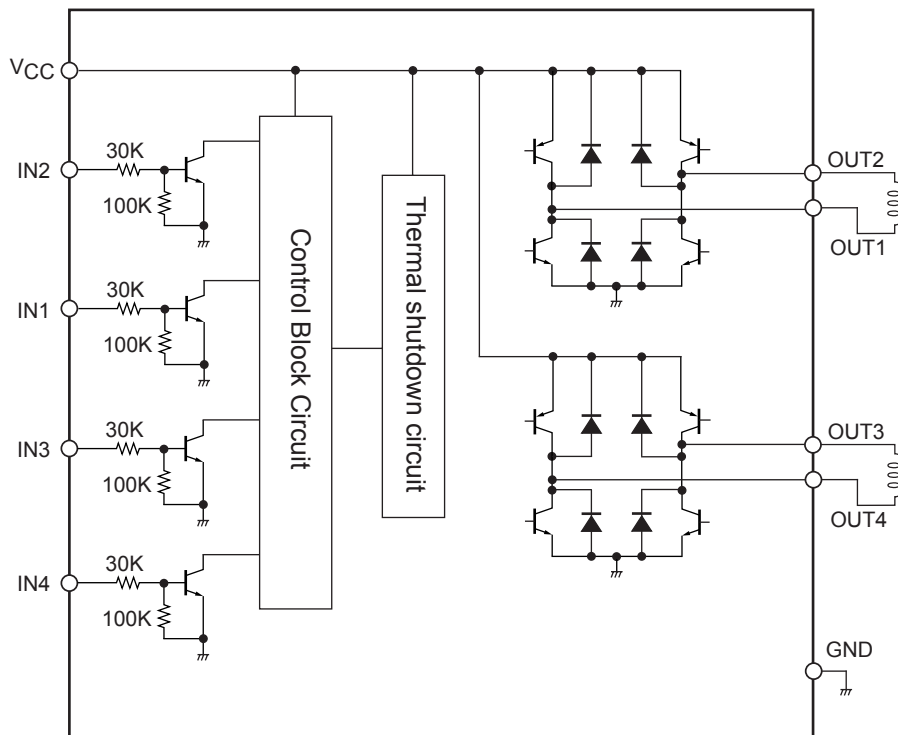

- SANYO Semiconductor Co.,Ltd. assumes no responsibility for equipment failures that result from using products at values that exceed, even momentarily, rated values (such as maximum ratings, operating condition ranges, or other parameters) listed in products specifications of any and all SANYO Semiconductor Co.,Ltd. products described or contained herein.
- SANYO Semiconductor Co.,Ltd. strives to supply high-quality high-reliability products, however, any and all semiconductor products fail or malfunction with some probability. It is possible that these probabilistic failures or malfunction could give rise to accidents or events that could endanger human lives, trouble that could give rise to smoke or fire, or accidents that could cause damage to other property. When designing equipment, adopt safety measures so that these kinds of accidents or events cannot occur. Such measures include but are not limited to protective circuits and error prevention circuits for safe design, redundant design, and structural design.
- In the event that any or all SANYO Semiconductor Co.,Ltd. products described or contained herein are controlled under any of applicable local export control laws and regulations, such products may require the export license from the authorities concerned in accordance with the above law.
- No part of this publication may be reproduced or transmitted in any form or by any means, electronic or mechanical, including photocopying and recording, or any information storage or retrieval system, or otherwise, without the prior written consent of SANYO Semiconductor Co.,Ltd.
- Any and all information described or contained herein are subject to change without notice due to product/technology improvement, etc. When designing equipment, refer to the "Delivery Specification" for the SANYO Semiconductor Co.,Ltd. product that you intend to use.
- Information (including circuit diagrams and circuit parameters) herein is for example only; it is not guaranteed for volume production.
- Upon using the technical information or products described herein, neither warranty nor license shall be granted with regard to intellectual property rights or any other rights of SANYO Semiconductor Co.,Ltd. or any third party. SANYO Semiconductor Co.,Ltd. shall not be liable for any claim or suits with regard to a third party's intellectual property rights which has resulted from the use of the technical information and products mentioned above.

This catalog provides information as of March, 2012. Specifications and information herein are subject to change without notice.



Компания «ЭлектроПласт» предлагает заключение долгосрочных отношений при поставках импортных электронных компонентов на взаимовыгодных условиях!

Наши преимущества:

- Оперативные поставки широкого спектра электронных компонентов отечественного и импортного производства напрямую от производителей и с крупнейших мировых складов;
- Поставка более 17-ти миллионов наименований электронных компонентов;
- Поставка сложных, дефицитных, либо снятых с производства позиций;
- Оперативные сроки поставки под заказ (от 5 рабочих дней);
- Экспресс доставка в любую точку России;
- Техническая поддержка проекта, помощь в подборе аналогов, поставка прототипов;
- Система менеджмента качества сертифицирована по Международному стандарту ISO 9001;
- Лицензия ФСБ на осуществление работ с использованием сведений, составляющих государственную тайну;
- Поставка специализированных компонентов (Xilinx, Altera, Analog Devices, Intersil, Interpoint, Microsemi, Aeroflex, Peregrine, Syfer, Eurofarad, Texas Instrument, Miteq, Cobham, E2V, MA-COM, Hittite, Mini-Circuits, General Dynamics и др.);

Помимо этого, одним из направлений компании «ЭлектроПласт» является направление «Источники питания». Мы предлагаем Вам помощь Конструкторского отдела:

- Подбор оптимального решения, техническое обоснование при выборе компонента;
- Подбор аналогов;
- Консультации по применению компонента;
- Поставка образцов и прототипов;
- Техническая поддержка проекта;
- Защита от снятия компонента с производства.



Как с нами связаться

Телефон: 8 (812) 309 58 32 (многоканальный)

Факс: 8 (812) 320-02-42

Электронная почта: org@eplast1.ru

Адрес: 198099, г. Санкт-Петербург, ул. Калинина, дом 2, корпус 4, литера А.