

Introducing Mezalok Connector

*(High Reliability Mezzanine
Connector)*

KEY FEATURES

60 and 114 positions

Mini-Box contact system provides 4 points of contact for ultra reliability

LCP plastic housings offer superior thermal stability and are low-outgassing

Compliant BGA board attach supports standard surface mount processing and excellent thermal stability

114 position footprint compatible to XMC footprint and all dimensional constraints

DESCRIPTION

Rugged surface mount mezzanine connector incorporating “super-redundant” Mini-Box contact system for separable interface.

Designed for 10mm and 12mm stack heights in both 60 and 114 positions.

APPLICATIONS

Stacking or mezzanine applications

114 position is designed to support VITA 61 XMC architecture as rugged alternative to VITA 42 XMC

60 position designed for custom architecture stacking applications

ELECTRICAL

Stacking or mezzanine applications

114 position is designed to support VITA 61 XMC architecture as rugged alternative to VITA 42 XMC

60 position designed for custom architecture stacking applications

MECHANICAL

500 mating cycles durability

Mating force: 0.30 lb. max. times number of contacts

-65°C to +125°C operating temperature

Shock and vibration per VITA 47 requirements

MATERIALS

Pin Assembly: LCP plastic housings, white in color

Socket Assembly: LCP plastic housings, white in color

Contacts: High Performance Copper Alloy, 50μ” Au in mating interface (Sn/Pb and SAC305 solder balls are available)

STANDARDS & SPECS

114 position conforms to requirement of VITA 61 (VITA 42 Alternate)

VITA 42 and VITA 61 are not intermateable, but are footprint and XMC architecture compatible

APPLICATION TOOLING

Product is installed via standard BGA surface mount processes.

ORDERING INFORMATION



4 pin contact

Part Number	Description
114 Position:	
2102060-1	Assembly, pin housing, tin-lead, 1.27 μ m gold
2102060-2	Assembly, pin housing, lead-free, 1.27 μ m gold
2102060-3	Assembly, pin housing, tin-lead, 0.76 μ m gold
2102060-4	Assembly, pin housing, lead-free, 0.76 μ m gold
2102061-1	Assembly, socket housing, tin-lead, 10 mm, 1.27 μ m gold
2102061-2	Assembly, socket housing, lead-free, 10 mm, 1.27 μ m gold
2102061-3	Assembly, socket housing, tin-lead, 12 mm, 1.27 μ m gold
2102061-4	Assembly, socket housing, lead-free, 12 mm, 1.27 μ m gold
2102061-5	Assembly, socket housing, tin-lead, 10 mm, 0.76 μ m gold
2102061-6	Assembly, socket housing, lead-free, 10 mm, 0.76 μ m gold
2102061-7	Assembly, socket housing, tin-lead, 12 mm, 0.76 μ m gold
2102061-8	Assembly, socket housing, lead-free, 12 mm, 0.76 μ m gold
2102061-9	Assembly, socket housing, tin-lead, 18 mm, 1.27 μ m gold
1-2102061-0	Assembly, socket housing, lead-free, 18 mm, 1.27 μ m gold
1-2102061-1	Assembly, socket housing, tin-lead, 18 mm, 0.76 μ m gold
1-2102061-2	Assembly, socket housing, lead-free, 18 mm, 0.76 μ m gold
60 Position:	
2102079-1	Assembly, pin housing, tin-lead, 1.27 μ m gold
2102079-2	Assembly, pin housing, lead-free, 1.27 μ m gold
2102079-3	Assembly, pin housing, tin-lead, 0.76 μ m gold
2102079-4	Assembly, pin housing, lead-free, 0.76 μ m gold
2102080-1	Assembly, socket housing, tin-lead, 10 mm, 1.27 μ m gold
2102080-2	Assembly, socket housing, lead-free, 10 mm, 1.27 μ m gold
2102080-3	Assembly, socket housing, tin-lead, 12 mm, 1.27 μ m gold
2102080-4	Assembly, socket housing, tin-lead, 12 mm, 1.27 μ m gold
2102080-5	Assembly, socket housing, tin-lead, 10 mm, 0.76 μ m gold
2102080-6	Assembly, socket housing, lead-free, 10 mm, 0.76 μ m gold
2102080-7	Assembly, socket housing, tin-lead, 12 mm, 0.76 μ m gold
2102080-8	Assembly, socket housing, lead-free, 12 mm, 0.76 μ m gold

Pin — 2102060

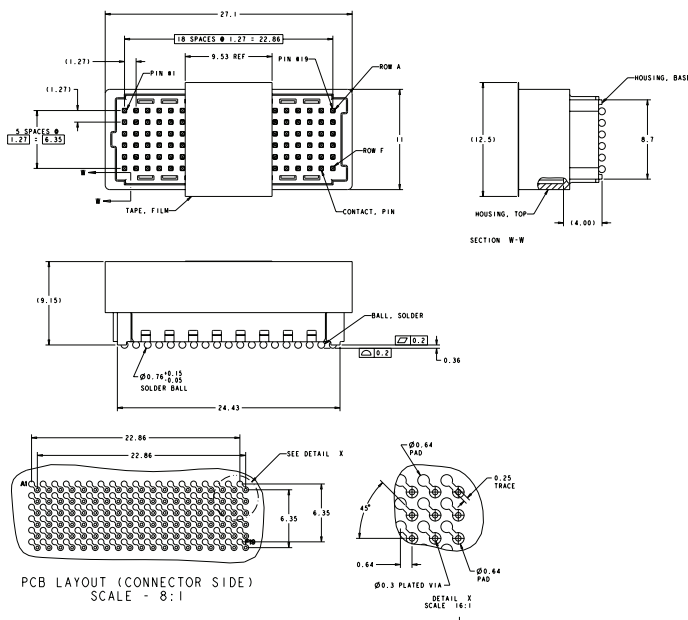

Socket — 2102061

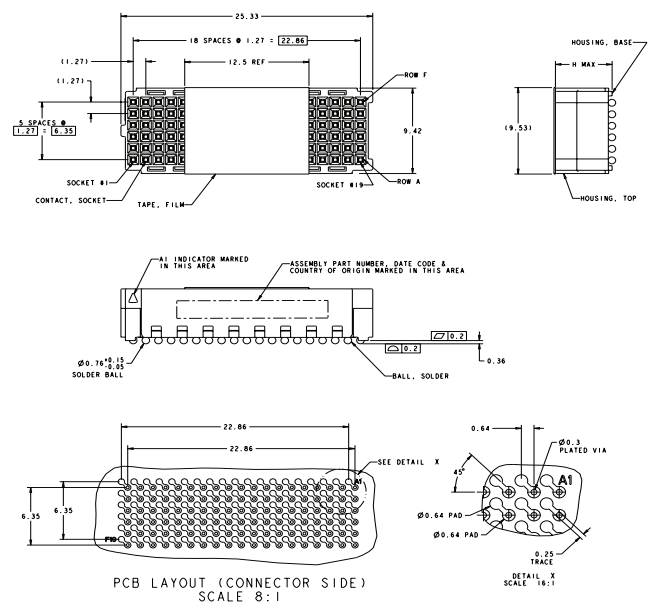

FOR MORE INFORMATION

Technical Support

Internet: www.tycoelectronics.com/ADM
E-mail: product.info@tycoelectronics.com

USA: +1 (800) 522-6752
Canada: +1 (905) 470-4425
Mexico: +52 (0) 55-1106-0814
C. America: +52 (0) 55-1106-0814
South America: +55 (0) 11-2103-6000
Germany: +49 (0) 6251-133-1999
Great Britain: +44 (0) 8706-080208
France: +33 (0) 1-3420-8686
Netherlands: +31 (0) 73-6246-999
China: +86 (0) 400-820-6015

Tyco Electronics Corporation
Harrisburg, PA

tycoelectronics.com

©2010 Tyco Electronics Corporation

2-1773457-3 — ADM — FP — 2.5M — 10/10
TE (logo) and Tyco Electronics are trademarks.

 **Tyco Electronics**
Our commitment. Your advantage.



Компания «ЭлектроПласт» предлагает заключение долгосрочных отношений при поставках импортных электронных компонентов на взаимовыгодных условиях!

Наши преимущества:

- Оперативные поставки широкого спектра электронных компонентов отечественного и импортного производства напрямую от производителей и с крупнейших мировых складов;
- Поставка более 17-ти миллионов наименований электронных компонентов;
- Поставка сложных, дефицитных, либо снятых с производства позиций;
- Оперативные сроки поставки под заказ (от 5 рабочих дней);
- Экспресс доставка в любую точку России;
- Техническая поддержка проекта, помощь в подборе аналогов, поставка прототипов;
- Система менеджмента качества сертифицирована по Международному стандарту ISO 9001;
- Лицензия ФСБ на осуществление работ с использованием сведений, составляющих государственную тайну;
- Поставка специализированных компонентов (Xilinx, Altera, Analog Devices, Intersil, Interpoint, Microsemi, Aeroflex, Peregrine, Syfer, Eurofarad, Texas Instrument, Miteq, Cobham, E2V, MA-COM, Hittite, Mini-Circuits, General Dynamics и др.);

Помимо этого, одним из направлений компании «ЭлектроПласт» является направление «Источники питания». Мы предлагаем Вам помощь Конструкторского отдела:

- Подбор оптимального решения, техническое обоснование при выборе компонента;
- Подбор аналогов;
- Консультации по применению компонента;
- Поставка образцов и прототипов;
- Техническая поддержка проекта;
- Защита от снятия компонента с производства.



Как с нами связаться

Телефон: 8 (812) 309 58 32 (многоканальный)

Факс: 8 (812) 320-02-42

Электронная почта: org@eplast1.ru

Адрес: 198099, г. Санкт-Петербург, ул. Калинина, дом 2, корпус 4, литера А.