

UNCONTROLLED DOCUMENT

PART NUMBER		REV.
LCM-X01602DXX/B		A
REV.	E.C.N. NUMBER AND REVISION COMMENTS	DATE
A	E.C.N. #10BRDR. & REDRAWN.	9-3-98

LCM-X	DXX	DESCRIPTION
STANDARD	S	SR STN, REFLECTIVE
		SF STN, TRANSFLECTIVE(W/ BACKLIGHT)
HIGH TEMP.	H	TR TN, REFLECTIVE
		TF TN, TRANSFLECTIVE(W/ BACKLIGHT)

CAUTION: STATIC SENSITIVE DEVICE  
FOLLOW PROPER E.S.D. HANDLING PROCEDURES  
WHEN WORKING WITH THIS PART.

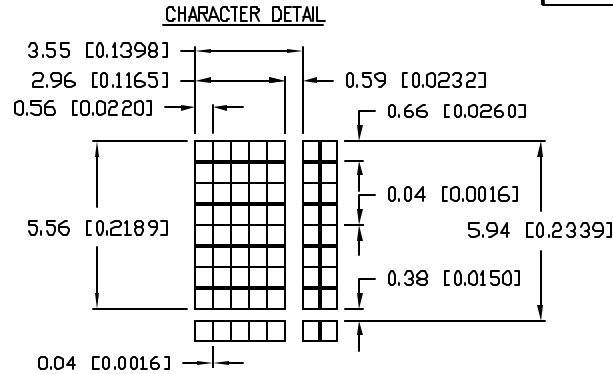

TYPE	DIM.	A	B
WITH BACKLIGHT		12.7	8.7
NO BACKLIGHT		8.8	4.8

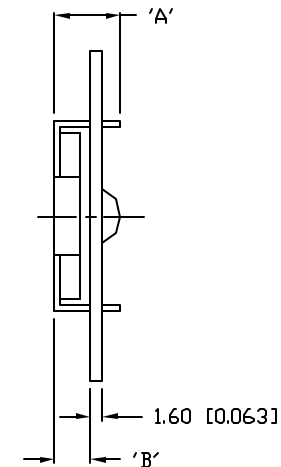
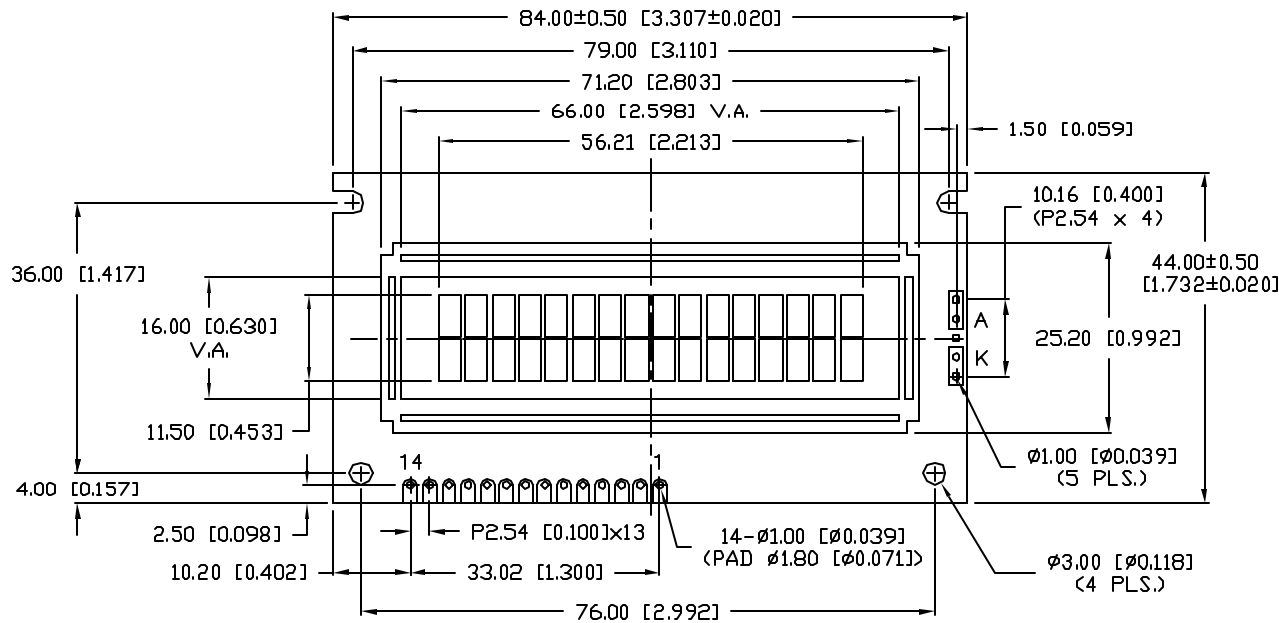

UNCONTROLLED DOCUMENT

\*UNLESS OTHERWISE SPECIFIED TOLERANCE IS ±0.25mm (±0.010")

REV. A	PART NUMBER LCM-X01602DXX/B	<p>CONFIDENTIAL INFORMATION</p> <p>THE INFORMATION CONTAINED IN THIS DOCUMENT IS THE PROPERTY OF LUMEX INC. EXCEPT AS SPECIFICALLY AUTHORIZED IN WRITING BY LUMEX INC., THE HOLDER OF THIS DOCUMENT SHALL KEEP ALL INFORMATION CONTAINED HEREIN CONFIDENTIAL AND SHALL PROTECT SAME IN WHOLE OR IN PART FROM DISCLOSURE AND DISSEMINATION TO ALL THIRD PARTIES.</p> <p>RELIABILITY NOTE</p> <p>OUR MANY YEARS OF EXPERIENCE DATA ACCUMULATION INDICATE THAT SOLDER HEAT IS A MAJOR CAUSE OF EARLY AND FUTURE FAILURE. PLEASE PAY ATTENTION TO YOUR SOLDERING PROCESS.</p>	<p><b>LUMEX</b> INCORPORATED</p> <p>290 E. HELLEN ROAD PALATINE, ILLINOIS 60067 PHONE: 1-847-359-2790 WEB: HTTP://WWW.LUMEX.COM</p>
5.56mm CHARACTER HEIGHT, 5 x 8 DOT MATRIX, 16 x 2 LCD MODULE, 1/16 DUTY, 1/5 BIAS.		<p>DRAWN BY: SA/BC</p>	<p>CHECKED BY:</p> <p>APPROVED BY:</p> <p>DATE: 4-28-98</p> <p>PAGE: 1 OF 2</p> <p>SCALE: N/A</p>

PART NUMBER		REV.
LCM-X01602DXX/B		A
REV.	E.C.N. NUMBER AND REVISION COMMENTS	DATE
	SEE PAGE #1./	

PIN CONFIGURATION			FUNCTION
PIN NO.	SYMBOL	LEVEL	FUNCTION
1	V <sub>SS</sub>	-	POWER SUPPLY GND (0V) 5V FOR LCD DRIVE
2	V <sub>DD</sub>	-	
3	V <sub>O</sub>	-	
4	RS	H/L	REGISTER SELECT SIGNAL H: DATA INPUT L: INSTRUCTION INPUT
5	R/W	H/L	H: DATA READ (MODULE-->MPU) L: DATA WRITE (MODULE<<--MPU)
6	E	H,H->L	ENABLE
7~14	DB0~DB7	H/L	DATA BUS-SOFTWARE SELECTABLE 4 OR 8 BIT MODE.

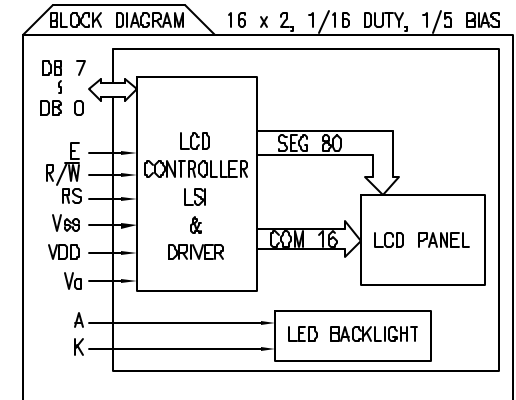
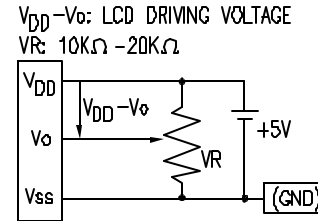

ELECTRICAL CHARACTERISTICS V<sub>DD</sub>=4.7V to 5.3V, T<sub>A</sub>=25°C

ITEM	SYMBOL	CONDITION	STANDARD VALUE			UNIT	
			MIN.	TYP.	MAX.		
SUPPLY VOLTAGE FOR LOGIC	V <sub>DD</sub> -V <sub>SS</sub>	-	-	5.0	-	V	
SUPPLY CURRENT FOR LOGIC	I <sub>DD</sub>	V <sub>DD</sub> =5V	-	2.0	3.0	mA	
INPUT VOLTAGE	HIGH	V <sub>IH</sub>	-	2.2	-	V <sub>DD</sub>	
	LOW	V <sub>IL</sub>	-	0	-	0.6	
OUTPUT VOLTAGE	HIGH	V <sub>OH</sub>	-	2.4	-	V	
	LOW	V <sub>OL</sub>	-	-	0.4	V	
*LED BACKLIGHT	VOLTAGE	V <sub>F</sub>	I <sub>F</sub> =160mA	-	4.2	4.6	V
	CURRENT	I <sub>F</sub>	-	-	160	-	mA
	POWER CONSUMPTION	P <sub>D</sub>	-	-	656	-	mW
	LUMINOUS	L	I <sub>F</sub> =160mA	70	-	-	cd/m <sup>2</sup>
	COLOR	-	-	-	-	-	nm

ABSOLUTE MAXIMUM RATINGS

ITEM	SYMBOL	TEST CONDITION	STANDARD VALUE		UNIT
SUPPLY VOLTAGE FOR LOGIC	V <sub>DD</sub> -V <sub>SS</sub>	T <sub>a</sub> =25°C	4.7	5.3	V
SUPPLY VOLTAGE FOR LCD DRIVE	V <sub>DD</sub> -V <sub>O</sub>	-	4.2@50°C	4.8@0°C	V
INPUT VOLTAGE	V <sub>I</sub>	T <sub>a</sub> =25°C	V <sub>SS</sub>	V <sub>DD</sub>	V
OPERATING TEMPERATURE	T <sub>opr</sub>	LCM-S	0	50	°C
		LCM-H	-20	70	°C
STORAGE TEMPERATURE	T <sub>stg</sub>	LCM-S	-20	70	°C
		LCM-H	-30	85	°C

\*ONLY APPLIES TO MODULES WITH BACKLIGHT

\*UNLESS OTHERWISE SPECIFIED TOLERANCE IS ±0.25mm (±0.010")

REV. A	PART NUMBER LCM-X01602DXX/B	<p>CONFIDENTIAL INFORMATION</p> <p>THE INFORMATION CONTAINED IN THIS DOCUMENT IS THE PROPERTY OF LUMEX INC. EXCEPT AS SPECIFICALLY AUTHORIZED IN WRITING BY LUMEX INC., THE HOLDER OF THIS DOCUMENT SHALL KEEP ALL INFORMATION CONTAINED HEREIN CONFIDENTIAL AND SHALL PROTECT SAME IN WHOLE OR IN PART FROM DISCLOSURE AND DISSEMINATION TO ALL THIRD PARTIES.</p> <p>RELIABILITY NOTE</p> <p>OUR MANY YEARS OF EXPERIENCE DATA ACCUMULATION INDICATE THAT SOLDER HEAT IS A MAJOR CAUSE OF EARLY AND FUTURE FAILURE. PLEASE PAY ATTENTION TO YOUR SOLDERING PROCESS.</p>	<p><b>LUMEX</b> INCORPORATED</p> <p>290 E. HELLEN ROAD PALATINE, ILLINOIS 60067 PHONE: 1-847-359-2790 WEB: HTTP://WWW.LUMEX.COM</p>
5.56mm CHARACTER HEIGHT, 5 x 8 DOT MATRIX, 16 x 2 LCD MODULE, 1/16 DUTY, 1/5 BIAS.		<p>DRAWN BY: SA/BC</p> <p>CHECKED BY:</p> <p>APPROVED BY:</p> <p>DATE: 4-28-98</p> <p>PAGE: 2 OF 2</p> <p>SCALE: N/A</p>	



Компания «ЭлектроПласт» предлагает заключение долгосрочных отношений при поставках импортных электронных компонентов на взаимовыгодных условиях!

Наши преимущества:

- Оперативные поставки широкого спектра электронных компонентов отечественного и импортного производства напрямую от производителей и с крупнейших мировых складов;
- Поставка более 17-ти миллионов наименований электронных компонентов;
- Поставка сложных, дефицитных, либо снятых с производства позиций;
- Оперативные сроки поставки под заказ (от 5 рабочих дней);
- Экспресс доставка в любую точку России;
- Техническая поддержка проекта, помощь в подборе аналогов, поставка прототипов;
- Система менеджмента качества сертифицирована по Международному стандарту ISO 9001;
- Лицензия ФСБ на осуществление работ с использованием сведений, составляющих государственную тайну;
- Поставка специализированных компонентов (Xilinx, Altera, Analog Devices, Intersil, Interpoint, Microsemi, Aeroflex, Peregrine, Syfer, Eurofarad, Texas Instrument, Miteq, Cobham, E2V, MA-COM, Hittite, Mini-Circuits, General Dynamics и др.);

Помимо этого, одним из направлений компании «ЭлектроПласт» является направление «Источники питания». Мы предлагаем Вам помощь Конструкторского отдела:

- Подбор оптимального решения, техническое обоснование при выборе компонента;
- Подбор аналогов;
- Консультации по применению компонента;
- Поставка образцов и прототипов;
- Техническая поддержка проекта;
- Защита от снятия компонента с производства.



#### Как с нами связаться

**Телефон:** 8 (812) 309 58 32 (многоканальный)

**Факс:** 8 (812) 320-02-42

**Электронная почта:** [org@eplast1.ru](mailto:org@eplast1.ru)

**Адрес:** 198099, г. Санкт-Петербург, ул. Калинина, дом 2, корпус 4, литера А.