

nRF8001

Single-chip *Bluetooth*[®] low energy solution

Product Specification 1.1

Key Features

- *Bluetooth* low energy peripheral device
- Stack features:
 - Low energy PHY layer
 - Low energy link layer slave
 - Low energy host for devices in the peripheral role
 - Proprietary Application Controller Interface (ACI)
- Hardware features:
 - 16 MHz crystal oscillator
 - Low power 32 kHz ± 250 ppm RC oscillator
 - 32.768 kHz crystal oscillator
 - DC/DC converter
 - Temperature sensor
 - Battery monitor
 - Direct Test Mode interface
- Ultra low power consumption
- Single 1.9-3.6V power supply
- Temperature range -40 – 85°C
- Compact 5×5 mm QFN32 package
- RoHS compliant

Applications

- Sport and fitness sensors
- Health care sensors
- Proximity
- Watches
- Personal User Interface Devices (PUID)
- Remote controls

Liability disclaimer

Nordic Semiconductor ASA reserves the right to make changes without further notice to the product to improve reliability, function or design. Nordic Semiconductor ASA does not assume any liability arising out of the application or use of any product or circuits described herein.

Life support applications

Nordic Semiconductor's products are not designed for use in life support appliances, devices, or systems where malfunction of these products can reasonably be expected to result in personal injury. Nordic Semiconductor ASA customers using or selling these products for use in such applications do so at their own risk and agree to fully indemnify Nordic Semiconductor ASA for any damages resulting from such improper use or sale.

Datasheet status	
Objective Product Specification	This product specification contains target specifications for product development.
Preliminary Product Specification	This product specification contains preliminary data; supplementary data may be published from Nordic Semiconductor ASA later.
Product Specification	This product specification contains final product specifications. Nordic Semiconductor ASA reserves the right to make changes at any time without notice in order to improve design and supply the best possible product.

Contact details

For your nearest dealer, please see www.nordicsemi.com

Main office:

Otto Nielsens veg 12
 7004 Trondheim
 Phone: +47 72 89 89 00
 Fax: +47 72 89 89 89
www.nordicsemi.com



RoHS statement

Nordic Semiconductor's products meet the requirements of Directive 2002/95/EC of the European Parliament and of the Council on the Restriction of Hazardous Substances (RoHS). Complete hazardous substance reports as well as material composition reports for all active Nordic Semiconductor products can be found on our website www.nordicsemi.com.

Revision History

Date	Version	Description
October 2012	1.1	<ul style="list-style-type: none">Fixed C/I values in Table 12. on page 36.Added section 7.1.4 on page 23.Updated Figure 28. on page 62 through Figure 32. on page 64.Updated figures in section 20.5 on page 66 to highlight location of GATT server and client.Added additional information about the command response event to each section in chapter 24 on page 95 and chapter 25 on page 132.Re-ordered the sections in chapter 24 on page 95 by OpCode.
January 17th 2012	1.0	<ul style="list-style-type: none">First release of the Product SpecificationFixed minor issues throughout the documentUpdated the schematics, Figure 21. on page 51 and Figure 22. on page 53

Contents

1	Introduction	8
1.1	Prerequisites	8
1.2	Writing conventions	8
1.3	Bluetooth specification releases	8
2	Bluetooth Qualification ID	9
	Part A: nRF8001 Physical description.....	10
3	Product overview	11
4	Bluetooth low energy features	12
4.1	Features.....	13
5	Physical product overview	14
5.1	Package and pin assignment.....	14
5.2	Pin functions	15
6	Analog and physical features	16
6.1	RF transceiver	16
6.2	On-chip oscillators	16
6.3	DC/DC converter	18
6.4	Temperature sensor	19
6.5	Battery monitor	20
6.6	Dynamic Window Limiting.....	20
6.7	Application latency	20
7	Interfaces	21
7.1	Application Controller Interface (ACI)	21
7.2	Active signal.....	28
7.3	Direct Test Mode interface.....	28
8	nRF8001 configuration	30
9	Data storage and memory retention.....	32
9.1	Permanent Storage.....	32
9.2	Volatile Storage	32
10	Absolute maximum ratings	33
11	Operating conditions	34
12	Electrical specifications	35
12.1	Digital I/O signal levels	35
12.2	Radio characteristics	35
12.3	Analog feature characteristics	36
12.4	Current consumption parameters	37
13	Dynamic current consumption	39
13.1	Current consumption - connection	39
13.2	Current consumption - advertising.....	41
13.3	Current consumption calculation examples	43
13.4	Recommendations for low power operation	45

14	External component requirements and recommendations	46
14.1	16 MHz crystal oscillator specification requirements	46
14.2	External 16 MHz clock	47
14.3	32.768 kHz crystal specification requirements	47
14.4	Antenna Matching and Balun	48
14.5	DC/DC Converter requirements	48
14.6	PCB layout and decoupling guidelines	48
15	Mechanical specifications	49
16	Ordering information	50
16.1	Package marking	50
16.2	Abbreviations	50
16.3	Product options	50
17	Reference circuitry	51
17.1	Schematic for nRF8001 with DC/DC converter enabled	51
17.2	Layout	52
17.3	Bill of Materials	52
17.4	Schematic for nRF8001 with DC/DC converter disabled	53
17.5	Layout	54
17.6	Bill of Materials	54
	Part B: The nRF8001 Application Controller Interface (ACI)	55
18	Operating principle	56
18.1	Packet structure	57
19	ACI packet types	58
19.1	System commands	58
19.2	Data commands	58
19.3	Events	58
20	Service pipes	59
20.1	Functional description	59
20.2	Defining Service pipes	60
20.3	Data transfer on a service pipe	60
20.4	Transmit service pipes	60
20.5	Receive service pipes	66
20.6	Service pipe availability	72
21	Flow control	74
21.1	System command buffering	74
21.2	Data command buffering	74
21.3	Flow control initialization	77
22	Operational modes	78
22.1	Overview of operational modes	78
22.2	Sleep mode	80
22.3	Setup mode	80
22.4	Active mode	83
22.5	Test mode	87
22.6	RF PHY testing	88

23	Protocol reference	89
23.1	Command and event overview	90
24	System commands	95
24.1	Test (0x01).....	95
24.2	Echo (0x02)	96
24.3	DtmCommand (0x03)	97
24.4	Sleep (0x04)	99
24.5	Wakeup (0x05)	100
24.6	Setup (0x06)	101
24.7	ReadDynamicData (0x07)	102
24.8	WriteDynamicData (0x08).....	103
24.9	GetDeviceVersion (0x09).....	105
24.10	GetDeviceAddress (0x0A)	106
24.11	GetBatteryLevel (0x0B)	107
24.12	GetTemperature (0x0C).....	108
24.13	RadioReset (0x0E)	109
24.14	Connect (0x0F)	110
24.15	Bond (0x10)	112
24.16	Disconnect (0x11).....	114
24.17	SetTxPower (0x12).....	115
24.18	ChangeTimingRequest (0x13).....	116
24.19	OpenRemotePipe (0x14)	119
24.20	SetApplLatency (0x19)	121
24.21	SetKey (0x1A).....	123
24.22	OpenAdvPipe (0x1B)	125
24.23	Broadcast (0x1C).....	127
24.24	BondSecurityRequest (0x1D)	128
24.25	DirectedConnect (0x1E)	129
24.26	CloseRemotePipe (0x1F)	130
25	Data commands	132
25.1	SetLocalData (0x0D)	132
25.2	SendData (0x15).....	134
25.3	SendDataAck (0x16).....	135
25.4	RequestData (0x17).....	136
25.5	SendDataNack (0x18)	137
26	System Events	138
26.1	DeviceStartedEvent (0x81).....	138
26.2	EchoEvent (0x82)	139
26.3	HardwareErrorEvent (0x83).....	140
26.4	CommandResponseEvent (0x84).....	141
26.5	ConnectedEvent (0x85)	142
26.6	DisconnectedEvent (0x86).....	144
26.7	BondStatusEvent (0x87).....	145
26.8	PipeStatusEvent (0x88)	147
26.9	TimingEvent (0x89).....	150
26.10	DisplayKeyEvent (0x8E).....	151

26.11	KeyRequestEvent (0x8F).....	152
27	Data Events	153
27.1	DataCreditEvent (0x8A).....	153
27.2	PipeErrorEvent (0x8D).....	154
27.3	DataReceivedEvent (0x8C)	155
27.4	DataAckEvent (0x8B)	156
28	Appendix	157
28.1	ACI Status Codes	157
28.2	Bonding Status Codes	158
28.3	Error Codes	159
29	Glossary	160

1 Introduction

nRF8001 is a *Bluetooth*[®] low energy solution designed for operation in the peripheral role. By integrating a *Bluetooth* low energy compliant radio (PHY), slave mode link controller and host, nRF8001 offers you an easy way to add *Bluetooth* low energy connectivity to your application.

nRF8001 offers a serial interface (ACI) for configuration and control from your microcontroller. This microcontroller will in the remainder of this document be referred to as the application controller.

This document is divided into two parts:

- **Part A** defines the nRF8001 hardware and electrical specifications as well as operating procedures.
- **Part B** describes the Application Controller Interface (ACI); the logical interface between the nRF8001 and your application

1.1 Prerequisites

To fully understand this document a good knowledge of electronic and software engineering is required.

Knowledge of *Bluetooth* specification, Ver. 4.0, Volumes 1, 3, 4 and 6 is required to operate nRF8001 correctly and to understand the terminology used within this document.

1.2 Writing conventions

This product specification follows a set of typographic rules to ensure that the document is consistent and easy to read. The following writing conventions are used:

- Command and event names, bit state conditions, and register names are written in *Courier*.
- Pin names and pin signal conditions are written in **Courier New bold**.
- Placeholders for parameters are written in *italic regular text font*. For example, a syntax description of `Connect` will be written as: `Connect(TimeOut, AdvInterval)`.
- Fixed parameters are written in regular text font. For example, a syntax description of `Connect` will be written as: `Connect(0x00F0, Interval)`.
- Cross references are [underlined and highlighted in blue](#).

1.3 *Bluetooth* specification releases

This document is valid based on *Bluetooth* specification core v4.0 for a low energy device operating in the peripheral role.

2 **Bluetooth Qualification ID**

nRF8001 is listed as an EP-QDL on the Qualified listings page of the *Bluetooth* Special Interest Group website (<https://www.bluetooth.org/tpg/listings.cfm>).

For details on the design qualifications, please refer to the following qualification IDs:

- B019756: EP-QDL containing core PICS.
- B017566: RF PHY Component QDL containing layout and schematics for the EP-QDL reference design.

Part A: nRF8001 Physical description

This section defines the physical features of nRF8001 and its electrical/mechanical specifications. It also defines the nRF8001 hardware, specifications and provides information on operating procedures.

3 Product overview

nRF8001's main physical features are the *Bluetooth* low energy PHY and the *Bluetooth* low energy stack that handles the link controller and host stack. It also includes additional analog sub-systems needed for the *Bluetooth* low energy operation, such as power management and several oscillator options.

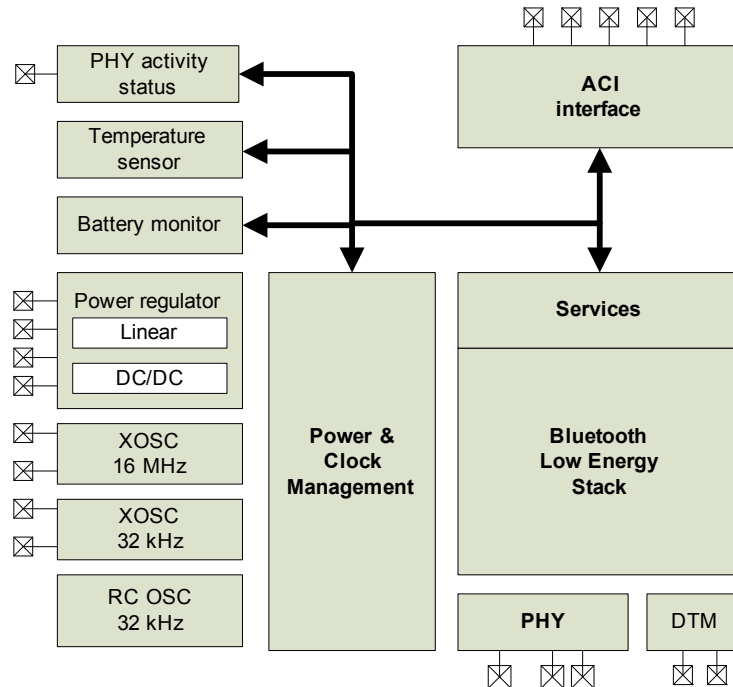

Figure 1. nRF8001 block diagram

nRF8001 has on-chip non-volatile memory for storing service configurations. This on-chip storage lets you select and combine the necessary services for your application, reducing the requirements on your application controller for handling all real-time operations related to the *Bluetooth* low energy communication protocol.

nRF8001 includes a power supply voltage monitor and a temperature sensor that further reduces the requirements to the application controller. These features are accessible through the Application Controller Interface (ACI).

nRF8001 also offers an optional output signal that is activated before the radio becomes active. This timing signal enables you to control the peak current drain of your application, avoiding overload of your power supply (for most applications this is usually a small battery). You can also use this timing signal to control the application circuitry, avoiding noise interference when the nRF8001 radio is operating.

A separate serial interface (UART) gives you access to the *Bluetooth* low energy Direct Test Mode (DTM). This interface is used to control the *Bluetooth* low energy radio (RF PHY) and is supported by commercially available *Bluetooth* test equipment used for *Bluetooth* qualification. This serial interface also enables you to test radio performance and to optimize your antenna.

4 Bluetooth low energy features

nRF8001 includes *Bluetooth* low energy protocols and profiles (see [Figure 2.](#)) that are defined in the *Bluetooth* specification 4.0 in the following volumes:

- Volume 2 Part D : Error Codes
- Volume 3: Core System Package Package [Host Volume]
 - Part A: Logical Link Control and Protocol
 - Part C: Generic Access Profile (GAP)
 - Part F: Attribute Protocol (ATT)
 - Part G: Generic Attribute Profile (GATT)
 - Part H: Security Manager (SM)
- Volume 6: Core System Package [Low Energy Controller Volume]

nRF8001 supports the peripheral role as defined in the *Bluetooth* low energy specification, Volume 3, Part C, 2.2.2.3 Peripheral Role. All mandatory features for a device operating in the peripheral role are supported. In addition to the mandatory features, a subset of optional features are available for use. Access to these features is specified in Part B of this document. Detailed information of the *Bluetooth* low energy features supported in nRF8001 can be found in the Bluetooth design listings as specified in [chapter 2 on page 9.](#)

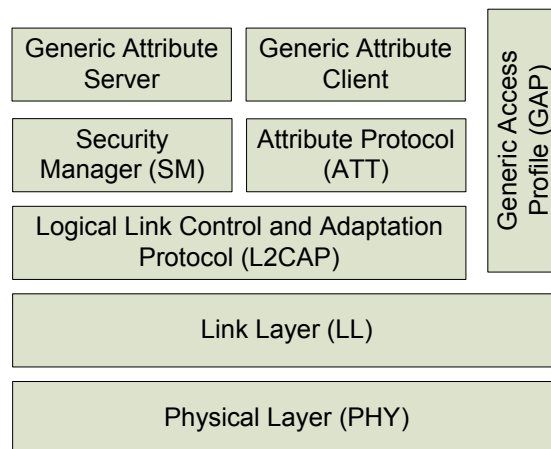

Figure 2. Bluetooth low energy layers implemented in nRF8001

4.1 Features

General nRF8001

- Radio features
 - *Bluetooth* low energy RF transceiver
 - Ultra low peak current consumption <14mA
 - Common Tx/Rx terminals
 - Low current for connection oriented profiles, typically 2µA
 - Ultra low current for connection-less oriented profiles, typically 500nA
- Auxiliary features
 - Integrated low frequency reference oscillator
 - Power management
 - Battery monitor
 - Temperature monitor
 - DC-DC converter that reduces current by up to 20% if enabled
 - Integrated 16 MHz crystal oscillator
 - OTP for customer configuration
- Interfaces
 - UART Test Interface for Direct Test Mode
 - Application Controller Interface (ACI)
 - Radio Active signal

nRF8001 *Bluetooth* low energy

- *Bluetooth* low energy stack
 - All layers up to GATT included in core software stack
- Link Layer Features
 - Slave role
 - Control PDUs in the slave role
 - 27 byte MTU
 - Encryption
- L2CAP
 - 27 byte MTU
 - Slave connection update
 - Attribute Channel
 - Security Channel
- General Access Profile (GAP) features
 - Discoverable modes
 - Dedicated bonding
 - GAP attributes
- Attribute Protocol
 - Mandatory client protocol
 - Mandatory server protocol
- Security Manager
 - Generation of keys for encryption
 - Just works security
 - Passkey entry
- Generic Attribute Profile (GATT)
 - Mandatory client profile features
 - Mandatory server profile features
- Direct Test Mode (DTM)
 - DTM for RF qualification

5 Physical product overview

This section describes the physical properties of nRF8001.

5.1 Package and pin assignment

nRF8001 is available in a 5x5 mm QFN32 package. The backplate of the QFN32 capsule must be grounded to the application PCB in order to achieve optimal performance. The physical dimensions of nRF8001 are presented in [chapter 15 on page 49](#).

[Figure 3](#) shows the pin assignment for nRF8001 and [Table 1. on page 15](#) describes the pin functionality.

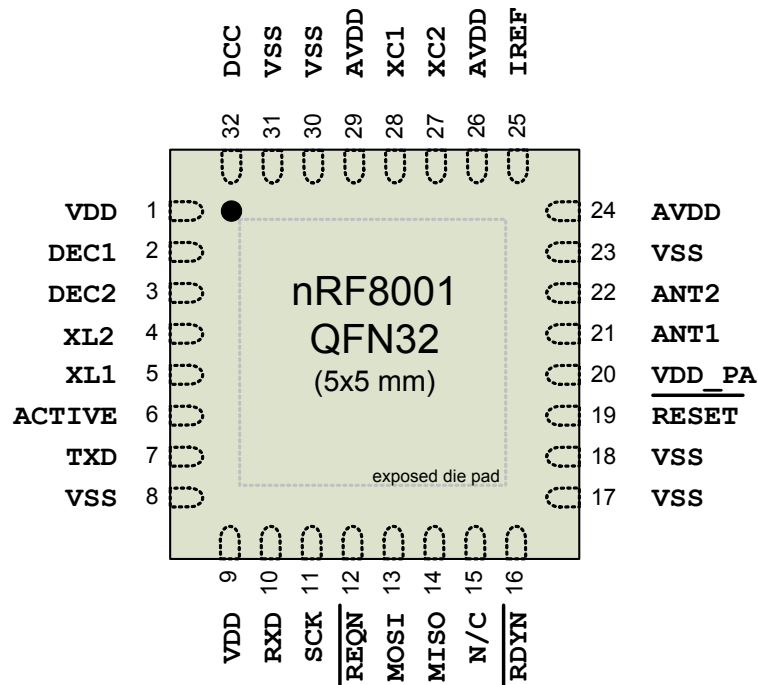

Figure 3. nRF8001 pin assignment (top view)

5.2 Pin functions

Pin	Pin name	Pin function	Description
1	VDD	Power	Power supply (1.9 – 3.6V)
2	DEC1	Power	Regulated power supply output for decoupling purposes only. Connect 100nF capacitor to ground
3	DEC2	Power	Regulated power supply output for decoupling purposes only. Connect 33nF capacitor to ground
4	XL2	Analog output	Connect to 32.768 kHz crystal oscillator. If internal RC oscillator is enabled, this pin shall not be connected.
5	XL1	Analog input	Connect to 32.768 kHz crystal oscillator or external 32.768 kHz clock reference. If internal RC oscillator is enabled, this pin shall not be connected. If using a digital clock, this pin must be defined when entering sleep mode.
6	ACTIVE	Digital output	Device RF front end activity indicator
7	TXD	Digital output	UART (transmit) for <i>Bluetooth</i> low energy Direct Test Interface
8	VSS	Power	Ground (0V)
9	VDD	Power	Power supply (1.9 – 3.6V)
10	RXD	Digital input	UART (receive) for <i>Bluetooth</i> low energy Direct Test Interface
11	SCK	Digital input	ACI clock input. Must be in a defined state at all times.
12	REQN	Digital input	ACI request pin (handshaking, active low). Must be in a defined state at all times.
13	MOSI	Digital input	ACI Master Out Slave In. Must be in a defined state at all times.
14	MISO	Digital output	ACI Master In Slave Out
15	N/C	Digital input	Not connected
16	RDYN	Digital output	ACI device ready indication (handshaking, active low)
17	VSS	Power	Ground (0V)
18	VSS	Power	Ground (0V)
19	RESET	Digital input	Reset (active low)
20	VDD_PA	Power output	Regulated power supply output for on-chip RF Power amplifier
21	ANT1	RF	Differential antenna connection (TX and RX)
22	ANT2	RF	Differential antenna connection (TX and RX)
23	VSS	Power	Ground (0V)
24	AVDD	Power	Analog power supply (1.9 – 3.6V DC)
25	IREF	Analog output	Current reference terminal. Connect 22 kΩ 1% resistor to ground
26	AVDD	Power	Analog power Supply (1.9 – 3.6V)
27	XC2	Analog output	Connection for 16 MHz crystal oscillator. Leave unconnected if not in use.
28	XC1	Analog input	Connection for 16 MHz crystal or external 16 MHz reference
29	AVDD	Power	Analog power supply (1.9 – 3.6V DC)
30	VSS	Power	Ground (0V)
31	VSS	Power	Ground (0V)
32	DCC	Power	Pulse Width Modulated (PWM) driver for the external LC filter if the DC/DC converter is enabled. If the DC/DC converter is disabled this pin shall be not connected.
Exposed die pad	VSS	Power	Ground (0V)

Table 1. nRF8001 pin functions

6 Analog and physical features

This chapter describes the analog and physical features of nRF8001.

The following analog features are included in nRF8001:

- *Bluetooth* low energy RF transceiver
- Three on-chip reference oscillators
- DC/DC converter for extended battery life with coin-cell batteries
- Temperature sensor
- Battery monitor

6.1 RF transceiver

nRF8001 includes an integrated RF transceiver which is compliant with the *Bluetooth* low energy specification Volume 6, Part A. The RF transceiver requires the following external components to operate:

- 16 MHz crystal
- Resistor for setting internal bias currents
- Balun to match an antenna to the receiver/ transmitter pins of nRF8001

6.1.1 Enabling the RF transceiver

All RF transceiver functionality and operation is controlled through the ACI. Configuring the GAP parameters and entering a mode of operation through the ACI enables the transceiver to send advertisement events and connect to a peer device. Data transfer is initiated after the negotiated *Bluetooth* low energy setup procedures have been completed.

6.2 On-chip oscillators

nRF8001 includes three integrated oscillators:

- Low power amplitude regulated 16 MHz crystal oscillator
- Ultra low power amplitude regulated 32.768 kHz crystal oscillator
- Ultra low power 32.768 kHz RC oscillator with ± 250 ppm frequency accuracy

The 16 MHz crystal oscillator provides the reference frequency for the RF transceiver. The two low frequency 32.768 kHz oscillators provide the protocol timing. Only one low frequency reference can be used at any one time. The choice of which reference to use depends on your application and will affect the design cost and current consumption. The low-frequency crystal oscillator clock can be driven by either a 32.768 kHz crystal oscillator or a 32.768 kHz external clock source.

6.2.1 Enabling the oscillators

The 16 MHz crystal oscillator is automatically enabled when nRF8001 requires it. The 32.768 kHz oscillator is automatically enabled when nRF8001 is in a connection or advertising state. Both the 32.768 kHz and the 16 MHz reference sources and oscillator settings are set through the ACI, see [Part B, section 22.3 on page 80](#).

6.2.2 16 MHz crystal oscillator

The 16 MHz crystal oscillator is designed for use with an AT-cut quartz crystal in parallel resonant mode. To achieve correct oscillation frequency, the load capacitance must match the specification in the crystal

datasheet. [Figure 4.](#) shows how the crystal is connected to the 16 MHz crystal oscillator.

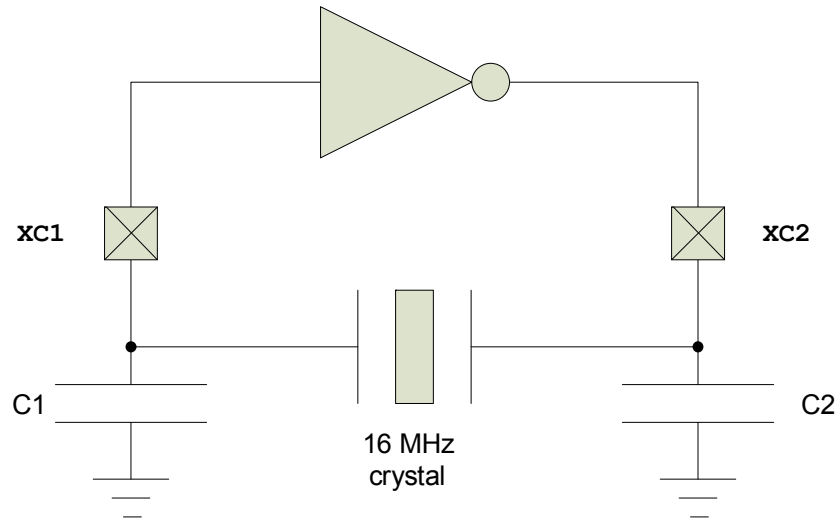

Figure 4. Circuit diagram of the nRF8001 16 MHz crystal oscillator

The load capacitance is the total capacitance seen by the crystal across its terminals and is given by:

$$C_{load} = \frac{(C1' \times C2')}{(C1' + C2')}$$

$$C1' = C1 + C_{pcb1} + C_{pin}$$

$$C2' = C2 + C_{pcb2} + C_{pin}$$

|

C1 and C2 are ceramic SMD capacitors connected between each crystal terminal and ground. C_{pcb1} and C_{pcb2} are stray capacitances on the PCB. C_{pin} is the pin input capacitance on the **xc1** and **xc2** pins, typically 1 pF. The load capacitance C1 and C2 should be of the same value.

6.2.3 External 16 MHz clock

nRF8001 may be used with an external 16 MHz reference applied to the **xc1** pin instead of a 16 MHz crystal. An input amplitude of 0.8 V peak-to-peak or higher is recommended to achieve low current consumption. Keep the maximum voltage level so that all peak voltages are under the recommended maximum operating conditions as specified in [chapter 11 on page 34](#). The external signal must have an accuracy of 40 ppm or better. The **xc1** pin loads the external application's crystal oscillator with approximately 1 pF in addition to PCB routing. Do not connect the **xc2** pin.

6.2.4 32.768 kHz crystal oscillator

The 32.768 kHz crystal oscillator is designed for use with a quartz crystal in parallel resonant mode. To achieve correct oscillation frequency, the load capacitance must match the specification in the crystal datasheet. [Figure 5. on page 18](#) shows how the crystal is connected to the 32.768 kHz crystal oscillator.

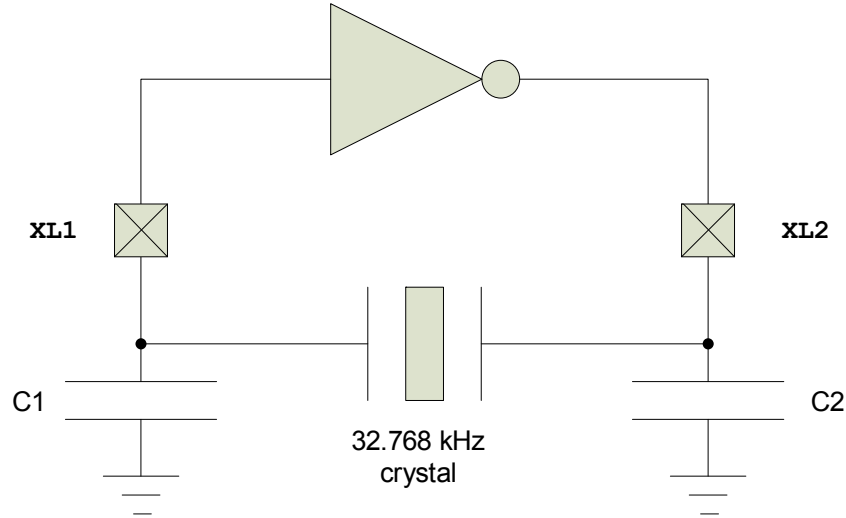

Figure 5. Circuit diagram of the nRF8001 32.768 kHz crystal oscillator

The load capacitance is the total capacitance seen by the crystal across its terminals and is given by:

$$C_{load} = \frac{(C1' \times C2')}{(C1' + C2')}$$

$$C1' = C1 + C_{pcb1} + C_{pin}$$

$$C2' = C2 + C_{pcb2} + C_{pin}$$

C1 and C2 are ceramic SMD capacitors connected between **xc1** and **xc2** and ground. C_{pcb1} and C_{pcb2} are stray capacitances on the PCB. C_{pin} is the input capacitance on the **xc1** and **xc2** pins, typically 1pF. C1 and C2 should be of the same value.

6.2.5 32.768 kHz RC oscillator

The nRF8001 32.768 kHz RC low frequency oscillator may be used as an alternative to the 32.768 kHz crystal oscillator. It has a frequency accuracy of ± 250 ppm in a stable temperature environment. The 32.768 kHz RC oscillator does not require external components.

6.2.6 External 32.768 kHz clock

nRF8001 may be used with an external 32.768 kHz clock applied to the **xl1** pin. The application controller sets the reference signal configuration. It can be a rail-to-rail signal or an analog signal. An analog input signal must have an amplitude of 0.2 V peak-to-peak or greater. Keep the maximum and minimum voltage levels so that all peak voltages are under recommended maximum operating conditions as specified in [chapter 11 on page 34](#). If the external source is derived from the application controller's crystal oscillator, the **xl1** pin will load the application's crystal oscillator with approximately 3pF in addition to PCB routing.

6.3 DC/DC converter

nRF8001 incorporates linear supply voltage regulators and an optional step-down DC/DC converter. The internal linear regulators are always enabled. When enabled, the step-down DC/DC converter transforms

the battery voltage to a lower internal voltage with minimal power loss. The converted voltage is then fed to the input of the linear regulators.

This feature is particularly useful for applications using battery technologies with higher nominal cell voltages. The reduction in supply voltage level from a high voltage to a low voltage reduces the peak power drain from the battery. Used with a 3 V coin cell battery, the peak current drawn from the battery is reduced by approximately 20%.

The DC/DC converter is functional only when operating from the internal 32.768 kHz RC oscillator (see [section 6.2.5 on page 18](#)) or from an external 32.768 kHz digital rail-to-rail clock (see [section 6.2.6 on page 18](#)).

[Figure 6](#) illustrates the peak current reduction in percentage (%) using the values for I_{RX_DC} and I_{TX_DC} in [Table 15](#) on page 37.

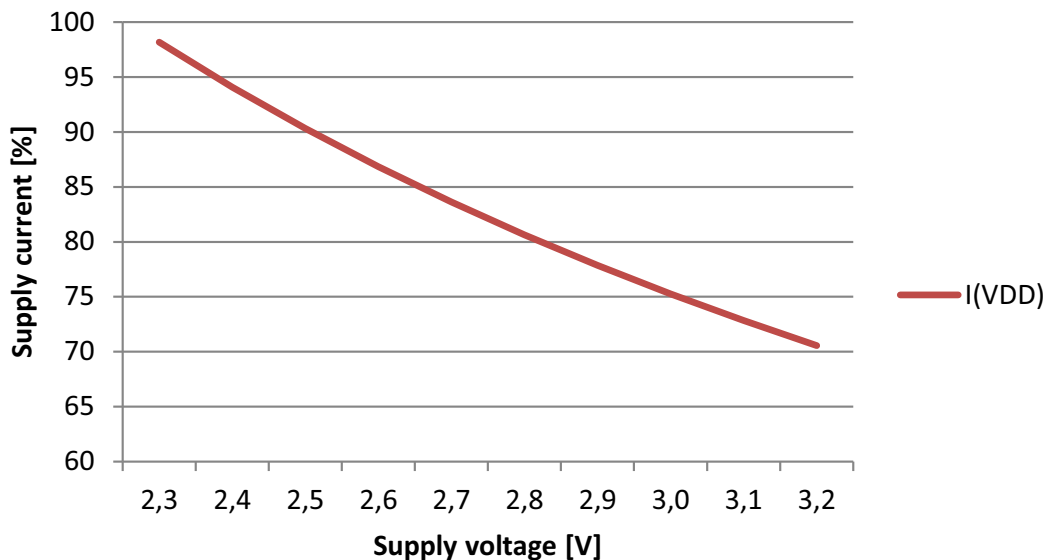

Figure 6. Relative current consumption over supply voltage with DC/DC converter enabled

Note: Three external discrete components are required in order to use the step-down converter. See [chapter 17 on page 51](#) for details on schematics, layout and BOM for the two power supply alternatives.

6.3.1 Enabling the DC/DC converter

You can enable the DC/DC converter through nRFGo Studio, see [Part B, section 22.3 on page 80](#).

6.4 Temperature sensor

nRF8001 incorporates an integrated temperature sensor. The temperature sensor reports the silicon temperature. The temperature sensor's electrical specifications are defined in [chapter 12 on page 35](#).

6.4.1 Enabling the temperature sensor

The temperature sensor is enabled through the ACI protocol, see [Part B, section 24 on page 95](#). When nRF8001 receives an ACI command initiating the temperature reading it will enable the temperature sensor and start the internal measurement procedure. Upon completion, nRF8001 returns an ACI event reporting the current temperature reading.

6.5 Battery monitor

nRF8001 incorporates an integrated battery monitor. The battery monitor reports the supply voltage (VDD) connected to nRF8001 supply pins. The battery monitor's electrical specifications are defined in [chapter 12 on page 35](#).

6.5.1 Enabling the battery monitor

The battery monitor sensor is enabled through the ACI protocol see [Part B, section 24 on page 95](#). When nRF8001 receives an ACI command initiating the battery reading it will enable the battery monitor and start the internal measurement procedure. Upon completion, the nRF8001 returns an ACI event reporting the current battery monitor reading.

6.6 Dynamic Window Limiting

Dynamic Window Limiting reduces the average current consumption by reducing the window widening of the receiver, see *Bluetooth* Specification, Ver. 4.0, Vol. 6, Part B, section 4.5.7. Dynamic Window Limiting is an optional feature that can be enabled or disabled using nRFgo Studio (see [section 22.3 on page 80](#) for more information on nRFgo Studio). Enabling this feature reduces the overall system ppm to an average of 20 ppm.

Note: Under conditions that cause a major disruption to either the local or peer low-frequency clock, the connection may become unstable and terminate.

6.7 Application latency

Application Latency is an optional feature that subrates the slave latency so that nRF8001 listens for the central device's packets at the subrated connection interval. When nRF8001 is in a connection, Application Latency can be enabled or disabled in real time (see Part B, [section 24.23 on page 127](#)). When it is enabled, it is used with Slave Latency, see *Bluetooth* Specification, Ver. 4.0, Vol. 6, Part B, section 4.5.1.

When Application Latency is enabled, nRF8001 does not turn on its transmitter and acknowledge an empty received packet. This saves nRF8001 current by returning to a low current mode, it also reduces the application latency between a central device and a peripheral device. If the received packet is empty but the MD (More Data) bit in the header is set to 1 then nRF8001 acknowledges the empty packet and listens in the same event for the data indicated by the MD bit.

The average current consumption of the link is significantly reduced compared to a regular continuous connection. But, the application latency of data both for the central and peripheral is significantly lower than for a connection using slave latency only.

7 Interfaces

This chapter defines the physical interfaces for nRF8001:

- Application Controller Interface (ACI)
- Active signal
- *Bluetooth* low energy Direct Test Interface

7.1 Application Controller Interface (ACI)

The Application Controller Interface (ACI) enables an application controller to communicate with nRF8001. The ACI consists of a physical transport which is described in this chapter and a logical interface which is described in Part B of this product specification.

7.1.1 Physical description

The physical ACI interface on nRF8001 consists of five pins. All ACI data exchanges use a standard SPI interface, with nRF8001 using a mode 0 slave interface to the application controller.

However, nRF8001 does not behave as a pure SPI slave device; nRF8001 can receive new data over-the-air at any time or be busy processing a connection event or new data. Consequently, the traditional CSN signal used to initiate an SPI transaction is replaced by two active low hand-shake signals; RDYN and REQN.

These hand shake signals allow nRF8001 to notify the application controller when it has received new data over-the-air and also to hold new data exchanges initiated by the application controller until it is ready to accept and process them. The ACI connections are shown in [Figure 7](#).

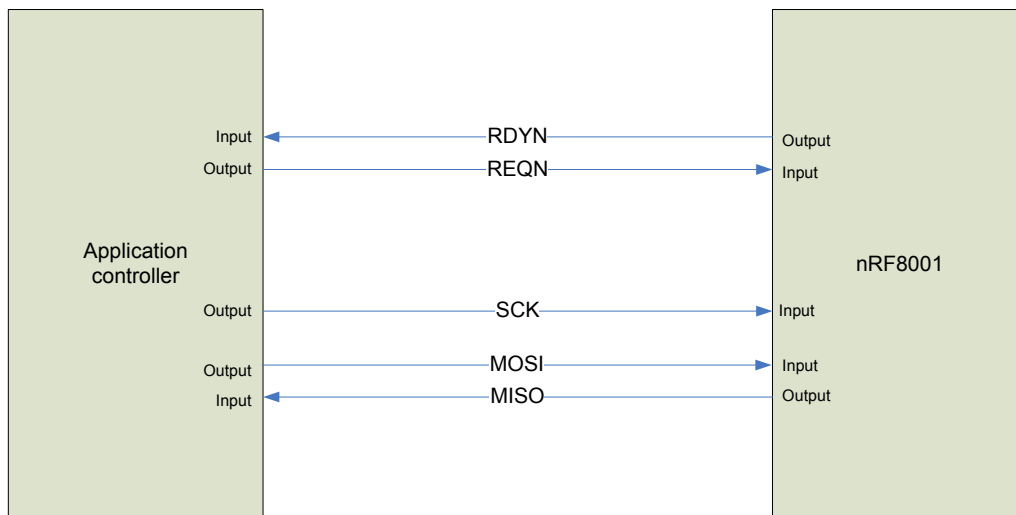

Figure 7. ACI interface between application controller and nRF8001

The data exchanges on the ACI interface are split into two types:

- Commands – Exchanges that are initiated by the application controller, including data that is sent from the application controller to nRF8001.

- Events – Exchanges that are initiated by nRF8001, including data that is sent from nRF8001 to the application controller.

If nRF8001 has event data ready for the application controller when the processor requests a command exchange, the command and event will be combined in a full duplex exchange. nRF8001 sends out the event data at the same time as it receives command data. To accommodate this, the application controller must always monitor the incoming data when issuing a command.

7.1.2 SPI mode

The ACI transport layer uses the SPI in the following mode (SPI mode 0):

Type	Value
Data order	Least significant bit first
Clock polarity	Zero (base value for the clock is zero)
Clock phase	Zero (data is read on the clock's rising edge)

Table 2. SPI signal description

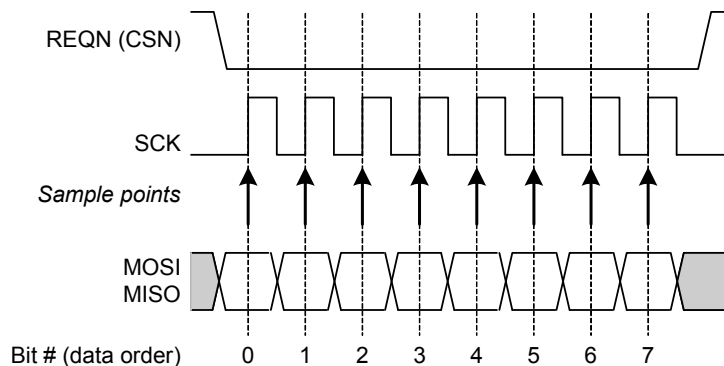

Figure 8. SPI mode 0 description

7.1.3 ACI connections

The required I/O pins needed on the application controller and nRF8001 for the ACI interface are listed in [Table 3](#).

Signal	Application controller	nRF8001	Description
MISO	Input	Output	SPI: Master In Slave Out
MOSI	Output	Input	SPI: Master Out Slave In
SCK	Output	Input	SPI: Serial data Clock
REQN	Output	Input	application controller to nRF8001 handshake signal
RDYN	Input	Output	nRF8001 to application controller handshake signal

Table 3. ACI I/O signals for an application controller and nRF8001

7.1.3.1 RDYn line

The application controller must, at all times, have the RDYn line configured as input with pull-up drivers. At power on reset and wake up from sleep scenarios, the RDYn level is valid after 62 ms from reset or wake up.

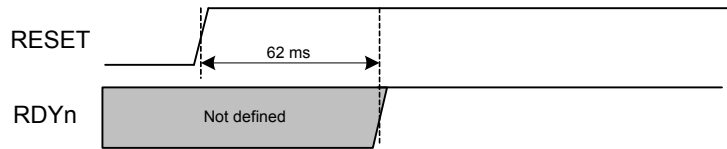

Figure 9. RDYn line functionality

Note: The supply rise time is not included in the power up sequence shown in [Figure 9](#).

7.1.4 ACI command exchange

[Figure 10](#) shows the signaling in an ACI command sent from the application controller to nRF8001.

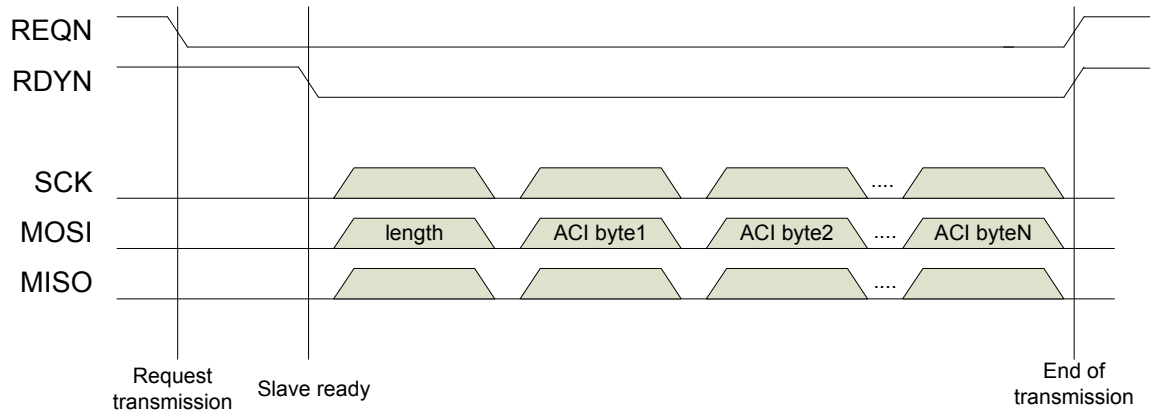

Figure 10. Data exchange from an application controller to nRF8001

The following procedure is performed when the application controller sends a command to nRF8001:

1. The application controller requests the right to send data by setting the **REQN** pin to ground.
2. nRF8001 sets the **RDYN** pin to ground when it is ready to receive data.
3. The application controller starts sending data on the **MOSI** pin:
 - Byte 1 (length byte) from the application controller defines the length of the message.
 - Byte 2 (ACI byte1) is the first byte of the ACI data.
 - Byte N is the last byte of the ACI data.
 - The application controller sets the **REQN** pin high to terminate the data transaction.

Note: The maximum length of a command packet is 32 bytes, including the length byte.

7.1.5 ACI event exchange

[Figure 11](#) shows the signaling in an ACI event exchange from nRF8001 to the application controller.

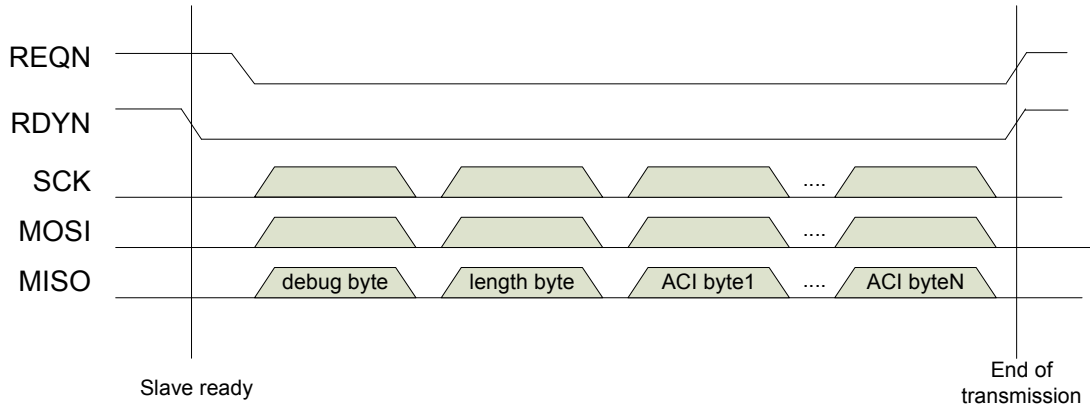

Figure 11. Receiving an ACI event from nRF8001

The application controller receives the ACI event by performing the following procedure:

1. nRF8001 sets the **RDYN** pin to ground.
2. The application controller sets the **REQN** pin to ground and starts sending the data from the **MISO** pin.
 - Byte 1 (debug byte) from nRF8001 is an internal debug byte and the application controller discards it.
 - Byte 2 (length byte) from nRF8001 defines the length of the message.
 - Byte 3 (ACI byte1) is the first byte of the ACI data.
 - Byte N is the last byte of the ACI data.
3. The application controller sets the **REQN** pin high to close the event.

Note: The maximum length of an event packet is 31 bytes, including the length byte.

7.1.6 ACI full-duplex transaction

nRF8001 is capable of receiving an ACI command simultaneously as it sends an ACI event to the application controller.

The application controller shall always read the length byte from nRF8001 and check if the length is greater than 0. If the length is greater than 0 the data on the MISO line shall be read as described in [section 7.1.5](#).

An ACI event received from the nRF8001 processor is never a reply to a command being simultaneously transmitted. For all commands, the corresponding event will always be received in a subsequent ACI transaction.

7.1.7 SPI timing

The signaling and timing of each byte transaction for the nRF8001 SPI interface are shown in [Figure 12.](#) and [Figure 13. on page 27.](#) Critical timing parameters are listed in [Table 4. on page 27](#)

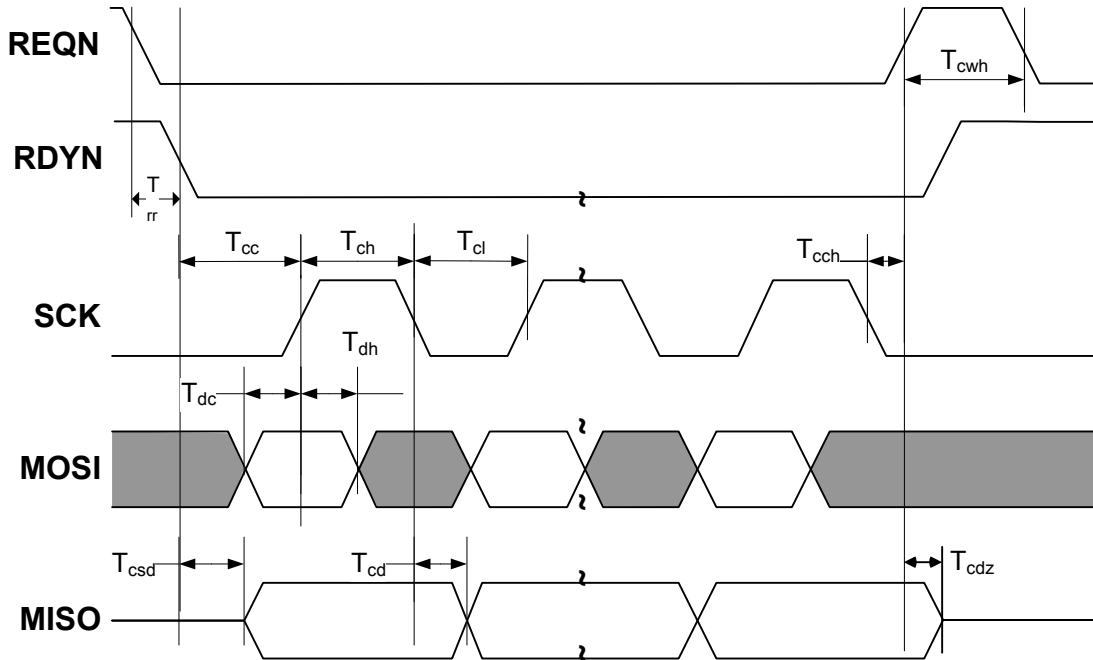

Figure 12. Application controller initiated packet SPI timing

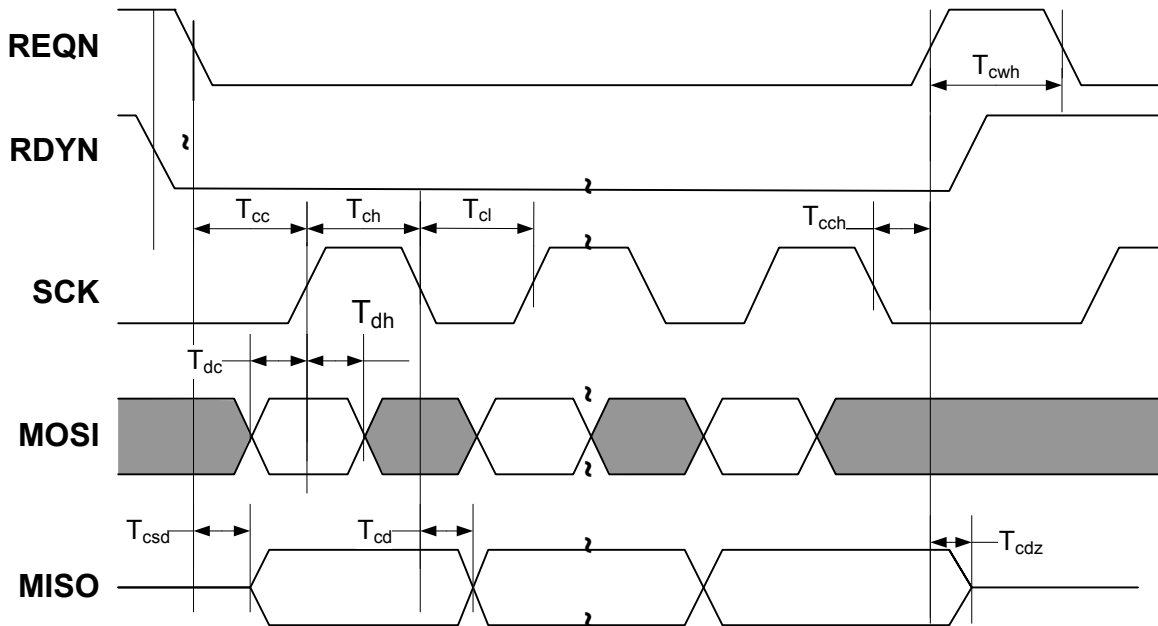

Figure 13. nRF8001 initiated packet SPI timing

Symbol	Description	Notes	Min	Max	Unit
T_{dc}	Data to SCK setup		15		ns
T_{dh}	SCK to Data Hold		5		ns
T_{csd}	REQN/RDYN to Data Valid			100	ns
T_{cd}	SCK to Data Valid		12	100	ns
T_{cl}	SCK Low time		40		ns
T_{ch}	SCK High time		40	20000	ns
T_{rr}	nRF8001 response time from REQN to RDYN	1	40		ns
F_{sck}	SCK frequency		0	3	MHz
T_r, T_f	REQN, SCK and MOSI rise time/fall time			15	ns
T_{cc}	REQN/RDYN to SCK setup		20		ns
T_{cch}	SCK to REQN hold		10		ns
T_{cwh}	REQN inactive time		250		ns
T_{cdz}	REQN to output high-Z			100	ns

1. The maximum response timing will be controlled by the radio event. If the REQN is activated at the start of a radio event, the RDYN response will be delayed until after the radio event is finished (plus typical response time).

Table 4. SPI timing parameters

Note: $C_{LOAD}=25$ pF, input transition to REQN, SCK and MOSI is in the range 5-15 ns. Rise and fall times are defined as the time when the signal is between 10-90 % of VDD.

7.2 Active signal

The active signal is an information signal provided by nRF8001. It indicates that the nRF8001 radio is active. The active signal can be used for the following purposes:

- As a trigger for the application controller to collect new sensor data (this must be completed before the radio becomes active see [Figure 14.](#)).
- To limit activity in the application controller to maintain minimum peak current load on the battery.
- To limit noise from the application affecting the radio transmissions by separating in the time domain the radio transmissions and application controller activity.

Its polarity can be configured active high or active low. When the active signal is asserted, nRF8001 will drain peak currents as described in [chapter 13 on page 39](#). The active signal can be configured to assert up to 20 ms before the nRF8001 radio is switched on, see [Figure 14](#). Jitter on this signal is $\pm 312.5 \mu\text{s}$ and the signal may occur early by up to 0.1% of the interval length, as a result of a 32 KHz oscillator drift.

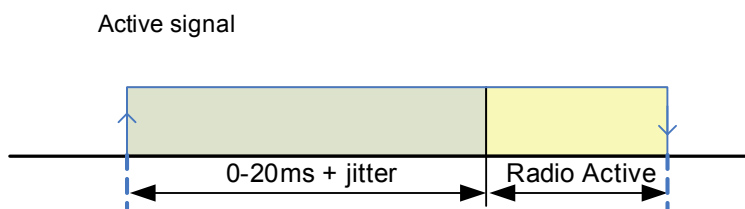

Figure 14. Active signal

Active signal is unavailable for advertising or connection intervals less than 30 ms regardless of prior configuration. If the active signal is enabled and the connection interval or advertising interval is below 30 ms, the active signal is automatically disabled. If a subsequent connection update increases the interval ≥ 30 ms, the active signal will automatically be re-enabled without a need for reconfiguration.

When both Slave Latency and the Active Signal are enabled, the Active signal will be present on every event to indicate that the processor is still active and consuming current.

7.3 Direct Test Mode interface

The Direct Test Mode (DTM) enables testing of the RF parameters of a *Bluetooth* low energy radio design. All *Bluetooth* low energy end products must include access to the DTM UART interface for end-product qualification testing of the RF transceiver layer.

The DTM has two modes of operation; the transmit test mode and the receive test mode. In transmit test mode, nRF8001 generates a predefined set of test packets. In receive test mode, nRF8001 counts the number of test packets received from a dedicated RF transceiver tester.

The nRFGo Studio enables RF transceiver testing using the DTM. For more information, visit www.nordicsemi.com. The *Bluetooth* low energy Direct Test Mode implemented in nRF8001 is described in the *Bluetooth* Specification, Ver. 4.0, Vol. 6, Part F.

7.3.1 Direct Test Mode interface characteristics

The DTM UART interface features:

- 2-wire UART interface (TXD/RXD)
- Baud rate: 19200
- Number of data bits: 8
- No parity
- 1 stop bit
- No flow control (meaning no RTS/CTS)

7.3.2 Functional description

The DTM is activated using the Application Controller Interface (ACI). When active, the nRF8001 *Bluetooth* low energy radio is controlled by 2-byte commands on the 2-wire UART interface (pins **TXD** and **RXD**) or alternatively, over the ACI. See the *Bluetooth* Specification, Ver 4.0, Vol 6, part F, for command word format and options.

When the DTM is active, the nRF8001 stack features are disabled. To exit test mode and return to normal operation, the ACI command Test(ExitTestMode) or a device reset can be used.

8 nRF8001 configuration

nRF8001's hardware and protocol parameters are configured through the nRFgo Studio (**nRF8001 Configuration** menu option), see Part B, [Section 22.3 on page 80](#). These parameters may be written to non-volatile memory and are permanently stored through all power modes, see [chapter 9 on page 32](#). These parameters are available from the Hardware Settings and the GAP Settings tabs in nRFgo Studio. Once programmed, the parameters set the circuit to a default state on power up or reset. The available configuration parameters that you can set are listed in [Table 5](#).

Hardware settings	Description	Default
32 KHz clock source	32.768 kHz reference source: <ul style="list-style-type: none"> Internal RC oscillator External crystal External digital clock External analog source 	Internal RC
32 KHz clock accuracy	32.768 kHz accuracy if using external source: <ul style="list-style-type: none"> 251 ppm to 500 ppm 151 ppm to 250 ppm 101 ppm to 150 ppm 76 ppm to 100 ppm 51 ppm to 75 ppm 31 ppm to 50 ppm 21 ppm to 30 ppm 0 ppm to 20 ppm If the default internal RC is used, this is set automatically to 151 to 250 ppm.	151 to 250 ppm
16 MHz clock source	Sets the input reference source and the start time of the internal 16 MHz reference clock: <ul style="list-style-type: none"> Digital source (500 us) Crystal source (1.5 ms) 	Crystal source
Initial TX power	Output power setting of PA: <ul style="list-style-type: none"> -18 dBm -12 dBm -6 dBm 0 dBm <p>Note: This parameter may also be changed in Active mode.</p>	0 dBm
DC/DC converter	Enables the DC/DC converter <p>Note: This cannot be enabled if the 32 KHz clock source is set to "External crystal".</p>	Disabled
Active signal	Sets active signal timing requirements: <ul style="list-style-type: none"> Enable/Disable 0 to 20 ms before event start <ul style="list-style-type: none"> Resolution = 312.5 us Polarity <ul style="list-style-type: none"> 0 positive 1 negative 	Disable

Hardware settings	Description	Default
Timing parameters	Preferred slave connection parameters for L2CAP connection update command: <ul style="list-style-type: none"> • Set maximum connection interval • Set minimum connection interval • Set slave latency • Set connection supervision timeout 	Min = User defined Max = User defined Latency = 0 Timeout = User defined
Minimum encryption key size	Minimum size of encryption key length acceptable for the application. Range is between 7 and 16 bytes.	7
Maximum encryption key size	Maximum size of encryption key length acceptable for the application. Range is between 7 and 16 bytes.	16
Security - Authentication requirement	Sets the authentication level required for transfer of security keys for nRF8001 (that is, it will not accept bonding below the required authentication level). <ul style="list-style-type: none"> • JUST WORKS • PASSKEY (MITM) 	Just works
Security - IO capability	Sets the IO capability <ul style="list-style-type: none"> • NONE • DISPLAY ONLY • KEYBOARD ONLY • DISPLAY YESNO • KEYBOARD/DISPLAY 	None
Bond timeout value	Timeout from entering bonding mode to receiving a pairing request from the peer device. <ul style="list-style-type: none"> • Resolution: second • Range: 0..65535 sec 	600 seconds
Security request delay timer	Delay time before sending security request packet when connecting to a bonded service. <ul style="list-style-type: none"> • Resolution: second • Range: 0..255 sec 	0 seconds
Dynamic Window Limiting	Enables the Dynamic Window Limiting feature	Disabled

Table 5. Configurable parameters set through nRFgo Studio

9 Data storage and memory retention

Data stored in nRF8001 is either stored in volatile or non-volatile memory, depending on the type of data. In this document, data is differentiated into two categories; static and dynamic data.

Static data:

nRF8001 can be configured through the ACI to hold hardware and protocol parameters, see [Part B, section 22.3 on page 80](#). Setup data can be written to non-volatile memory for permanent storage or to volatile memory during application development. Once programmed in non-volatile memory, the parameters set the circuit to the defined default state on power up or reset.

Dynamic data:

During normal runtime operation, your nRF8001 application will contain the Attributes and acquire information about peer devices and the services they offer. Your application may also establish a bonded relationship with a peer device. The information your application acquires as a result of normal runtime operation, is stored in nRF8001 volatile memory as dynamic data.

9.1 Permanent Storage

nRF8001 includes one time programmable Non-Volatile Memory (NVM). The hardware device setup and pipe setup as defined in [Part B, section 22.3 on page 80](#) are programmed into the NVM memory for permanent storage. Once information has been stored in NVM, it cannot be changed.

The nRFgo Studio configuration tool offers two setup file alternatives. One file will store the setup in NVM, the other will store the setup in volatile memory. For application development, setup storage in volatile memory will allow adjustments without discarding the device.

Note: Setup storage in volatile memory will be lost when the device is reset or power cycled.

9.2 Volatile Storage

Dynamic data is stored in RAM and will be lost if nRF8001 is power cycled or reset. Typical data stored in RAM includes profile client information, bonding addresses and keys.

Dynamic data may be read out of nRF8001 and stored in the application controller. Upon power cycling and attempting to re-enter a connection with a previously established relationship to a peer device, the data is written back into nRF8001 from the external application controller. This procedure is defined in [Part B, section 22.4.6 on page 86](#).

10 Absolute maximum ratings

Maximum ratings are the extreme limits to which nRF8001 can be exposed without permanently damaging it. Exposure to absolute maximum ratings for prolonged periods of time may affect nRF8001's reliability. [Table 6](#) specifies the absolute maximum ratings for nRF8001.

Parameter	Minimum	Maximum	Unit
Supply voltages			
VDD	-0.3	+3.6	V
VSS		0	V
I/O pin voltage			
V _{IO}	-0.3	VDD+0.3V	V
Temperatures			
Storage temperature	-40	+125	°C

Table 6. Absolute maximum ratings

Attention!

<p>Observe precaution for handling Electrostatic Sensitive Device.</p> <p>HBM (Human Body Model): Class 2</p>	
---	---

11 Operating conditions

The operating conditions are the physical parameters that nRF8001 can operate within. The operating conditions for nRF8001 are defined in [Table 7](#).

Symbol	Parameter (condition)	Notes	Min	Nominal	Max	Units
VDD	Supply voltage		1.9	3.0	3.6	V
VDD _{DC}	Supply voltage with DC/DC converter enabled		2.3	3.0	3.6	V
t _{R_VDD}	Supply rise time (0V to 1.9V)		1μs		50ms	μs and ms
T _A	Operating temperature		-40		+85	°C

Table 7. Operating conditions

12 Electrical specifications

This chapter contains electrical specifications for signal levels, radio parameters and, current consumption. The test levels referenced are defined in [Table 8](#).

Test level	Description
I	By design (simulation, calculation, specification limit)
II	Prototype verification @ EOC
III	Verified @ EOC in accordance with JEDEC47 (3 lots x 10 samples)
IV	100% test @ NOC

Table 8. Test level definitions

12.1 Digital I/O signal levels

The digital I/O signal levels are defined [Table 9](#). The operating conditions are: VDD = 3.0V, T_A = -40°C to +85°C (unless otherwise noted).

Symbol	Parameter (condition)	Test level	Min	Nom	Max	Unit
V _{IH}	Input high voltage	I	0.7×VDD		VDD	V
V _{IL}	Input low voltage	I	VSS		0.3×VDD	V
V _{OH}	Output high voltage (I _{OH} = 0.5 mA)	II	VDD-0.3			V
V _{OL}	Output low voltage (I _{OL} = 0.5 mA)	II			0.3	V

Table 9. Digital inputs/outputs

12.2 Radio characteristics

nRF8001 electrical characterization is defined in [Table 12](#). The operating conditions are: VDD = 3.0V, T_A = -40°C to +85°C (unless otherwise noted).

Symbol	Parameter (condition)	Test level	Notes	Min	Nom	Max	Unit
f _{OP}	Frequency operating range	I		2402		2480	MHz
f _{XTAL}	Crystal frequency	I			16		MHz
Δf	Frequency deviation	I			250		kHz
R _{GFSK}	On air data rate	I			1		Mbps
PLL _{RES}	RF channel spacing	I			2		MHz

Table 10. Radio general electrical characteristics

Symbol	Parameter (condition)	Test level	Notes	Min	Nom	Max	Unit
P _{RF}	Maximum output power	I	1		0	4	dBm
P ₋₆	Output power setting				-6		dBm
P ₋₁₂	Output power setting				-12		dBm
P ₋₁₈	Output power setting				-18		dBm
BW _{20dB}	20dB signal bandwidth	I			670		kHz
P _{RF1.1}	1st adjacent channel power	I			TBD		
P _{RF2.1}	2nd adjacent channel power	I			TBD		

1. Antenna load impedance = $15\Omega + j88$

Table 11. Radio transmitter electrical characteristics

Symbol	Parameter (condition)	Test level	Notes	Min	Nom	Max	Unit
P _{RX max}	Maximum input signal strength at PER $\leq 30.8\%$	I			0		dBm
P _{sens IT}	Receiver sensitivity: ideal transmitter	I			-87		dBm
P _{sens DT}	Receiver sensitivity: dirty transmitter	I	1		-86		dBm
P _{sens DC}	Receiver Sensitivity DC/DC Converter Enabled: dirty transmitter	I			-85		dBm
C/I _{CO}	Co-channel rejection	I			13		dB
C/I _{1st}	Adjacent channel selectivity: 1 MHz offset	I	1.		7		dB
C/I _{2nd}	Adjacent channel selectivity: 2 MHz offset	I	1.		-23		dB
C/I _{3+n}	Adjacent channel selectivity: (3+n) MHz offset [n=0,1,2...]	I	1.		-51		dB
C/I _{Image}	Image frequency rejection	I	1. and 2		-26		dB
P _{IM}	IMD performance (P _{in} =64 dBm)	I	1.		-38		dBm

1. As defined in Bluetooth V4.0 Volume 6: Core System Package [Low Energy Controller Volume].

2. Image frequency = $f_{RX} + 4$ MHz.

Table 12. Radio receiver electrical characteristics

12.3 Analog feature characteristics

Symbol	Parameter (condition)	Test level	Notes	Min	Nom	Max	Unit
T _{range}	Temperature Sensor Range	I		-40		85	C
T _{acc}	Temperature Sensor Accuracy	I		-2		2	C
B _{range}	Battery Monitor Range	I		1.9		3.6	V
B _{acc}	Battery Monitor Accuracy	I		-0.05		0.05	V

Table 13. Analog feature electrical characteristics

12.4 Current consumption parameters

The nRF8001 static current consumption is defined in [Table 14.](#) and [Table 15.](#) The dynamic current consumption is defined in [Figure 15. on page 38.](#)

The operating conditions are: VDD = 3.0V, T_A = -40°C to +85°C. The numbers in the column called **Reference to figures 17 and 19** in [Table 14.](#) and [Table 15.](#) refer to the numbers found in [Figure 17. on page 39](#) and [Figure 19. on page 41.](#)

Symbol	Parameter (condition)	Test level	Reference to figures 17 and 19	Min	Nom	Max	Unit
I _{RX}	Peak current, receiver active	I	2		14.6		mA
I _{TX}	Peak current, transmitter active	I	3		12.7		mA
I _{TFS}	Peak current when switching between receive and transmit	I	3		7		mA
I _{MCU_HOST}	Peak current for host processing	I	6		5		mA
I _{MCU_LL}	Peak current for LL processing	I	1 and 5		3.5		mA
I _{Standby}	Standby current,	I	1		1.6		mA
I _{idle}	Current drain between connection/ advertising events ACI = active mode, 32 kHz Osc active	I			2		μA
I _{sleep}	Current drain, connection-less state ACI = sleep mode	I			0.5		μA

Table 14. Current consumption for static values when DC/DC not active

Symbol	Parameter (condition)	Test level	Reference to figures 17 and 18	Min	Nom	Max	Unit
I _{RX_DC}	Peak current, receiver active	I	2		11.1		mA
I _{TX_DC}	Peak current, transmitter active		3		9.7		mA
I _{TFS_DC}	Peak current when switching between receive and transmit		3		7		mA
I _{MCU_HOST_DC}	Peak current for host processing	I	6		5		mA
I _{MCU_LL_DC}	Peak current for LL processing	I	1 and 5		3.6		mA
I _{Standby_DC}	Standby current	I	1		2.0		mA
I _{idle}	Current drain between connection/ advertising events ACI = active mode, 32 kHz Osc active	I			2		μA
I _{sleep}	Current drain, connection-less state ACI = sleep mode, with memory retention	I			0.5		μA

Table 15. Current consumption for static values when DC/DC converter active

Figure 15. shows the current consumption in RX and TX mode over the full temperature sensor range.

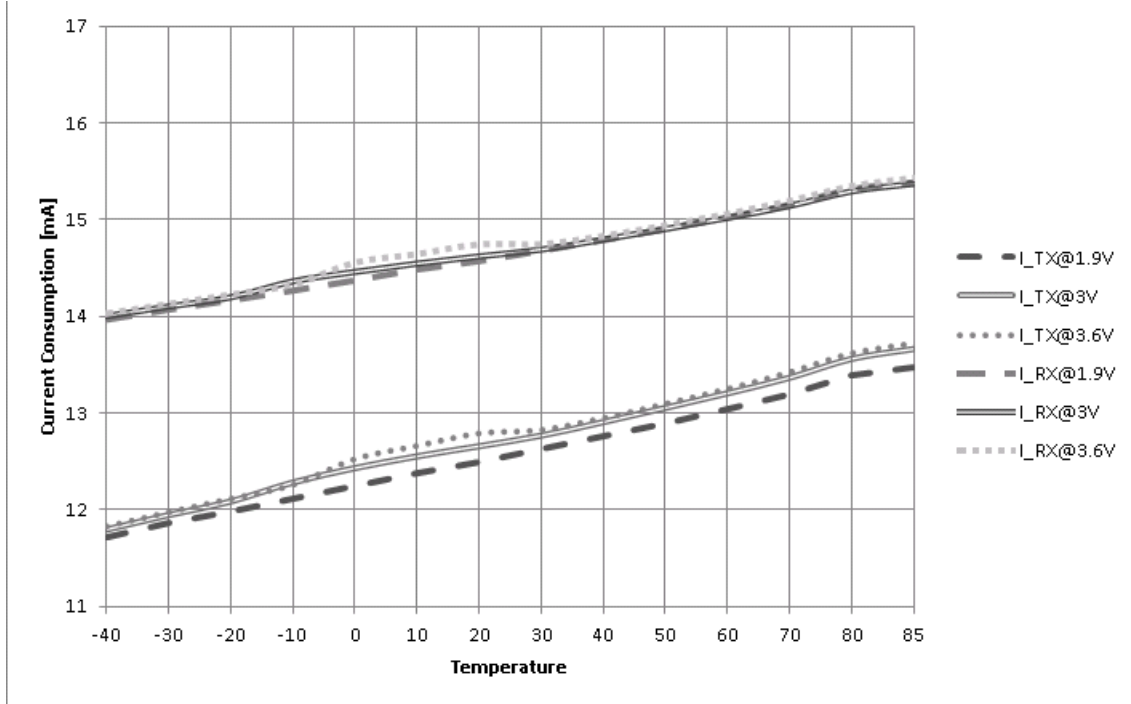

Figure 15. RX and TX current consumption with DC/DC converter not active

Figure 16. shows the current consumption in I_{idle} mode with the 32 kHz Oscillator active and in I_{sleep} mode over the full temperature sensor range..

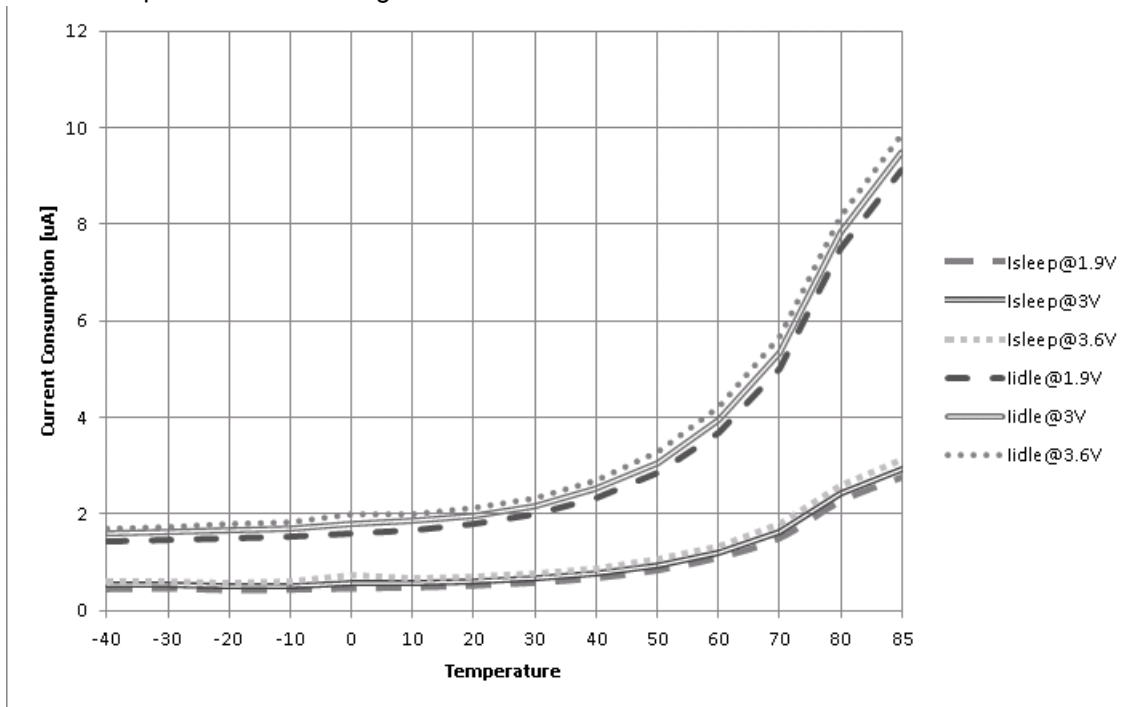

Figure 16. Current consumption in idle and Isleep with DC/DC converter not active

13 Dynamic current consumption

To predict battery lifetime, it is important to understand how the hardware and *Bluetooth* low energy protocol parameters influence the overall power consumption.

The connection and advertising events consist of a sequence of radio transmissions, each of which has individual current drain. The average power consumption of an event is calculated by integrating the current drain over the duration of the event.

Peak current consumption data is found in [section 12.4 on page 37](#).

13.1 Current consumption - connection

[Figure 17](#) illustrates the principle of current drain over time for a typical *Bluetooth* low energy device that is connected. The maximum peak-current drain occurs when the receiver is active ($I_{\text{peak_RX}}$).

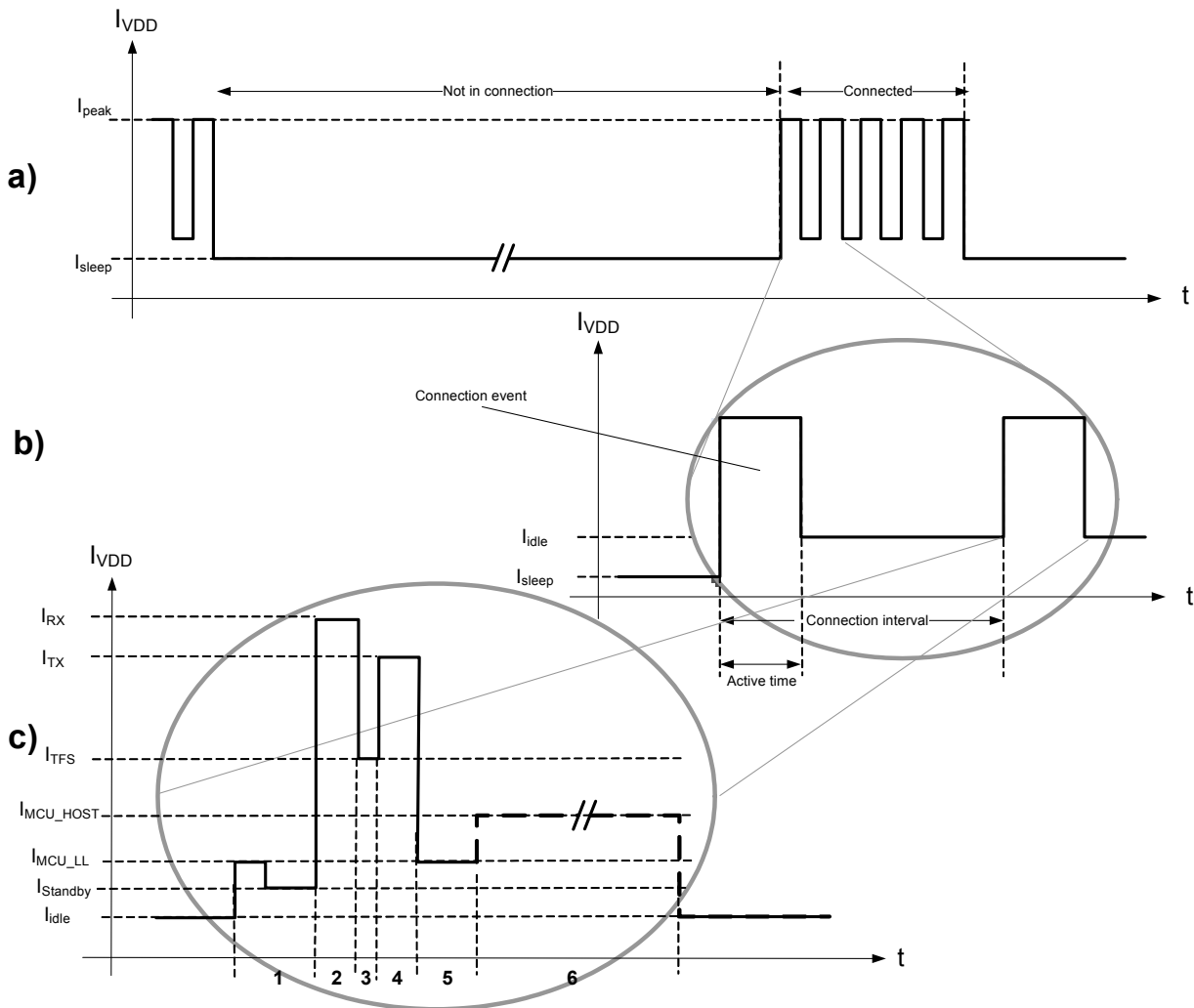

Figure 17. Current consumption over time for a typical nRF8001 connection event

Segment a) of [Figure 17](#) shows a typical scenario. A connection is defined as a physical radio connection between two *Bluetooth* low energy devices. This may consist of several connection events at a given

connection interval. The communication time is defined as the time that the *Bluetooth* low energy devices maintain the physical radio connection. It consists of one or more connection events separated in time by the connection interval. I_{sleep} is defined as the current consumption between communication intervals.

Segment b) of [Figure 17. on page 39](#) illustrates the periodicity of the connection interval. The average current drain of each connection event depends on the link parameter settings and ACI activity. I_{idle} is defined as the current drain between connection events.

Segment c) of [Figure 17. on page 39](#) illustrates a typical current drain profile for a connection event. Each connection event consists of the following states and operations (the numbers below correspond to the numbers displayed in segment c) of [Figure 17. on page 39](#)):

1. Radio pre-processing period
2. Active radio receive time
3. Radio Inter Frame Space (T_{IFS})
4. Active transmit time
5. Link layer post processing period
6. Data post processing period, enabled only if data has been received

[Figure 18.](#) shows the average current consumption (with and without the DC/DC converter enabled) as a function of the length of the connection interval.

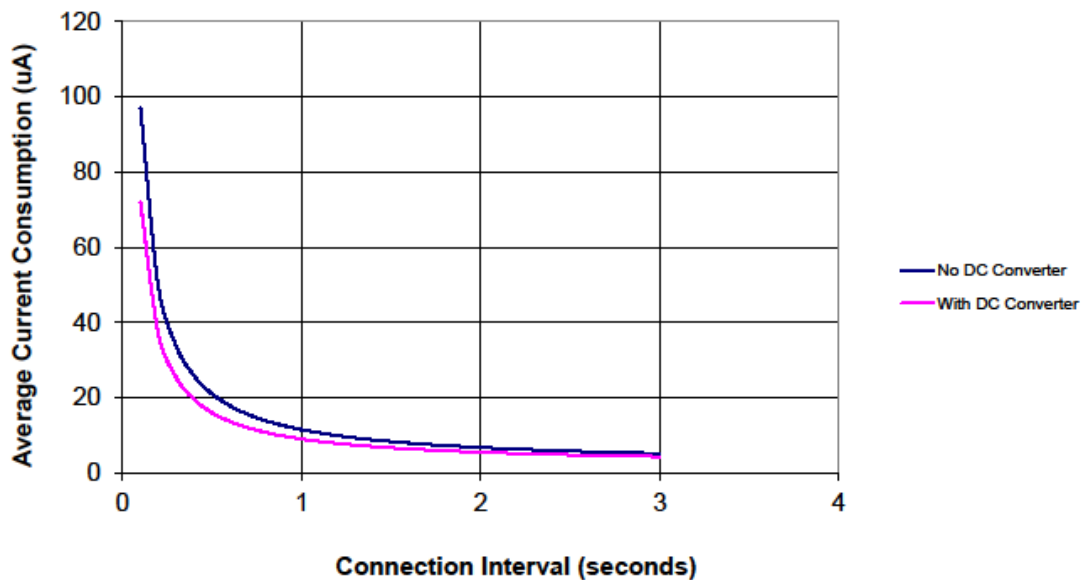

Figure 18. Graph showing average current consumption as a function of connection interval length

13.2 Current consumption - advertising

Figure 19 illustrates the principle of current drain over time for a typical *Bluetooth* low energy device that is advertising.

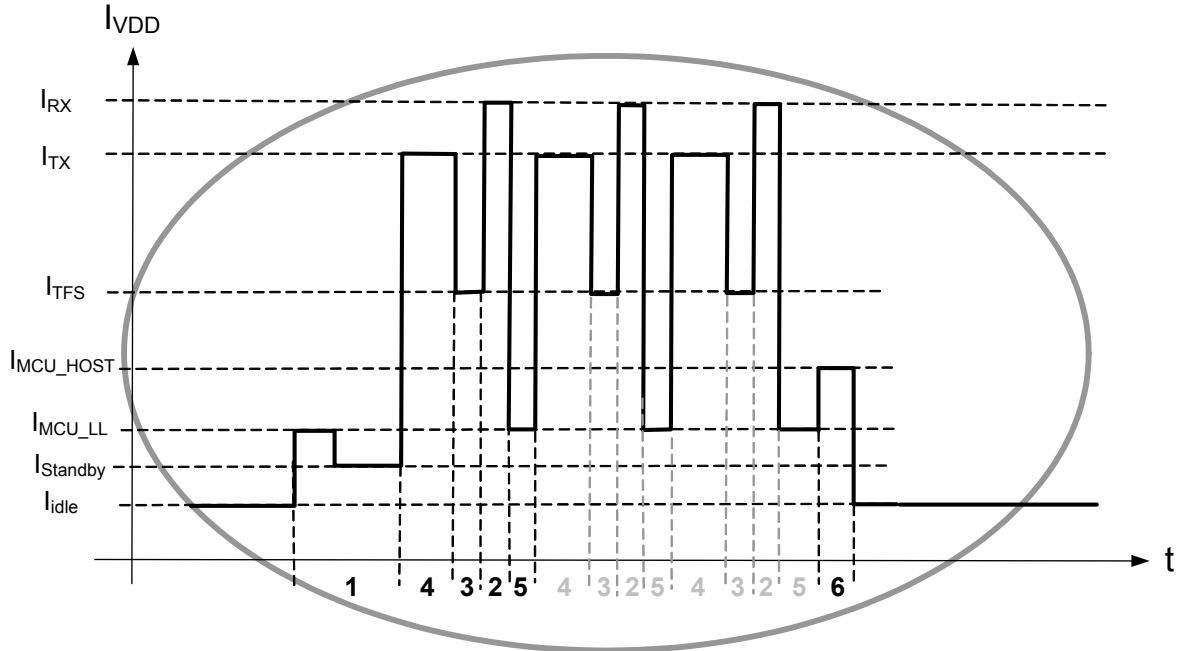

Figure 19. Current consumption over time for a typical nRF8001 advertising event

Each advertising event consists of the following states and operations (the numbers below correspond to the numbers displayed in [Figure 19. on page 41](#)):

1. Radio pre-processing period
2. Active radio receive time
3. Radio Inter Frame Space (T_{IFS})
4. Active transmit time
5. Link layer post processing period
6. Data post processing period, enabled only if data has been received

[Figure 20.](#) shows the average current consumption (with and without the DC/DC converter enabled) as a function of the length of the advertisement interval.

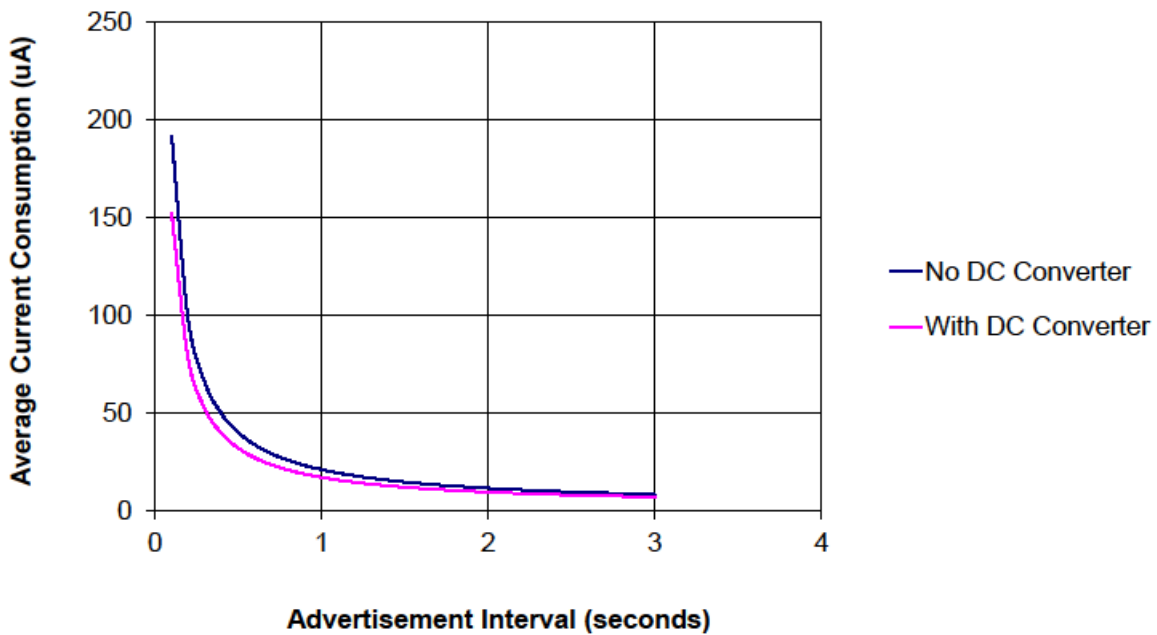

Figure 20. Graph showing average current consumption as a function of advertisement interval length

13.3 Current consumption calculation examples

You can calculate the average current consumption using the nRFgo Studio Current Consumption Calculator. For more information on nRFgo Studio, visit www.nordicsemi.com.

A set of typical profile scenario examples are presented below for different use cases based on typical profile scenarios. The current consumption values are calculated by the nRFgo Studio Current Consumption Calculator.

13.3.1 Estimated lifetime for proximity profile

The proximity profile typically has the following connection parameters:

- A 100% connection model, that is, the proximity tag is nearly always connected.
- 1 second connection interval.
- Zero data for 99% of the time, data is only sent if a condition is met, 4 bytes.
- Peripheral device is a server and initiates alerts upon receiving write commands.
- Pipe used: RX pipe.
- No encryption used.
- Total system sleep clock accuracy +/- 300ppm.
- 220 mAh coin cell battery.

	DC/DC converter disabled	DC/DC converter enabled	Unit
Average current consumption	16.5	13.5	µA
Calculated battery lifetime	18	22	months

Table 16. Average current consumption and battery lifetime with and without the DC/DC converter enabled for proximity profile

13.3.2 Estimated lifetime for heart rate profile

The heart rate profile typically has the following connection parameters:

- 1 hour per day connected.
- 1 second connection interval when connected.
- Data indicated every second, 4 bytes.
- Peripheral device is a server and indicates data.
- Pipe used: TX-Ack pipe.
- No encryption used.
- Total system sleep clock accuracy +/- 300 ppm.
- 220 mAh coin cell battery.

	DC/DC converter disabled	DC/DC converter enabled	Unit
Average current consumption	3.3	2.7	μA
Calculated battery lifetime	7.5	9	years

Table 17. Average current consumption and battery lifetime with and without the DC/DC converter enabled for heart rate profile

13.4 Recommendations for low power operation

Obtaining low power operation and long battery lifetime is a compromise between cost and performance. Here are some recommendations for obtaining suitable battery lifetimes:

- Use a reference source derived from an external high accuracy 32 kHz crystal source instead of the internal 32 kHz RC oscillator. Improving the total timing accuracy within the system can significantly reduce power consumption. This is a direct trade off of the cost of the 32.768 KHz crystal.
- Set Preferred Peripheral Connection Parameters for the application. The peer device operating in the central role defines the connection parameters to use for that connection. However, the peripheral device may request the peer device to change these to battery favorable parameters. Connection Interval and Slave Latency are important parameters in achieving suitable battery lifetime. These parameters are set by the ACI when nRF8001 is in the Setup mode as defined in [Part B section 22.3 on page 80](#)
- Using the DC/DC converter reduces the active peak currents as defined in [Table 15. on page 37](#) by approximately 20%. Additional external components are required when the DC/DC converter is enabled.
- Using the application latency feature (see [section 6.7 on page 20](#)) can reduce average current consumption if an application is running profiles that mainly consist of zero data but, that still require a low latency link from the central device to the peripheral device.
- Enabling the Dynamic Window Limiting feature reduces the average current consumption on a link.

14 External component requirements and recommendations

The tables in this chapter specify the crystal parameters that are required for nRF8001 to function and meet the *Bluetooth* low energy specification. [Table 18](#) specifies the requirements for the 16 MHz crystal. [Table 19 on page 47](#) specifies the requirements for the 32.768 kHz crystal.

14.1 16 MHz crystal oscillator specification requirements

The 16 MHz crystal oscillator is designed to be used with an AT-cut quartz crystal in parallel resonant mode. To achieve correct oscillation frequency it is very important that the load capacitance matches the specification in the crystal datasheet. The load capacitance C_L , as specified in the crystal datasheet, is the total capacitance seen by the crystal across its terminals:

$$C_{LOAD} = \frac{C_1' \cdot C_2'}{C_1' + C_2'}$$

$$C_1' = C_1 + C_{PCB1} + C_{PIN}$$

$$C_2' = C_2 + C_{PCB2} + C_{PIN}$$

C_1 and C_2 are ceramic SMD capacitors connected between each crystal terminal and VSS, C_{PCB1} and C_{PCB2} are stray capacitances on the PCB, while C_{PIN} is the input capacitance on nRF8001's **XC1** and **XC2** pins (typically 5pF). C_1 and C_2 should be of the same value, or as close as possible.

To ensure a functional radio link the frequency accuracy must be ± 40 ppm or better. The initial tolerance of the crystal, drift over temperature, aging and frequency pulling due to incorrect load capacitance must all be taken into account. For reliable operation the crystal parameters must comply with the specifications in [Table 18](#).

Symbol	Parameter (condition)	Notes	Min	Nom	Max	Units
F_{XO16}	16 MHz crystal frequency			16		MHz
Δf	Tolerance	1			± 40	ppm
C_L	Load capacitance		6	9	16	pF
C_0	Equivalent parallel capacitance			3	7	pF
L_S	Equivalent series inductance	2		30	50	mH
ESR	Equivalent series resistance			50	100	Ω
P_D	Drive level				100	μW

1. Frequency offset at 25 °C, temperature drift, aging and crystal loading
2. Startup time from power down is dependant on the L_S parameter

Table 18. 16 MHz crystal oscillator specifications

It is recommended to use a crystal with lower than maximum ESR if the load capacitance and/or shunt capacitance is high. This will give faster start-up and lower current consumption.

The start-up time is typically less than 1 ms for a crystal with 9 pF load capacitance and an ESR specification of 50 Ω . This value is valid for crystals in a 3.2 x 2.5 mm can. If you use the smallest crystal cans (like 2.0 x 2.5 mm), pay particular attention to the startup time of the crystal. These crystals have a longer startup than crystals in larger cans. To make sure the startup time < 1.5 ms use a crystal for load capacitance of 6pF. A low load capacitance will reduce both startup time and current consumption. For more details regarding how to measure the startup of a specific crystal, please see the nAN24-13 application note.

14.2 External 16 MHz clock

The nRF8001 may be used with an external 16 MHz clock applied to the **XC1** pin. An input amplitude of 0.8V peak-to-peak or higher is recommended to achieve low current consumption and a good signal-to-noise ratio. The DC level is not important as long as the applied signal never rises above **VDD** or drops below **VSS**. The **XC1** pin will load the microcontrollers crystal with approximately 5pF in addition to PCB routing. **XC2** shall not be connected.

Note: A frequency accuracy of ± 40 ppm or better is required to get a functional radio link.

14.3 32.768 kHz crystal specification requirements

For reliable operation the 32.768 kHz crystal load capacitance, shunt capacitance, Equivalent Series Resistance (ESR) and drive level must comply with the specifications listed in [Table 19](#).

Symbol	Parameter (condition)	Notes	Min	Nom	Max	Units
F_{XO32}	32.768 kHz crystal frequency			32.768		kHz
Δf	Tolerance	1	0		500	ppm
C_L	Load capacitance			9	12.5	pF
C_0	Equivalent parallel capacitance			1	2	pF
ESR	Equivalent series resistance			50	80	k Ω
P_D	Drive level				1	μ W

1. Frequency accuracy including tolerance at 25 °C, temperature drift, aging and crystal loading

Table 19. 32.768 kHz crystal specification

To achieve correct oscillation frequency it is important that the load capacitance matches the specification in the crystal datasheet. The load capacitance is the total capacitance seen by the crystal across its terminals:

$$C_L = \frac{C'_1 \cdot C'_2}{C'_1 + C'_2}$$

$$C'_1 = C_1 + C_{PCB1} + C_{PIN}$$

$$C'_2 = C_2 + C_{PCB2} + C_{PIN}$$

C1 and C2 are ceramic SMD capacitors connected between each crystal terminal and VSS, CPCB1 and CPCB2 are stray capacitances on the PCB, while CPIN is the input capacitance on the P0.0 and P0.1 pins of the nRF8001 (typically 3pF when configured as crystal pins). C1 and C2 should be of the same value, or as close as possible. It is recommended to use a crystal with lower than maximum ESR if the load capacitance and/or shunt capacitance is high. This will give faster start-up and lower current consumption.

The start-up time is typically less than 0.5s for a crystal with 9pF load capacitance, 1pF shunt capacitance and an ESR of 50 k Ω .

14.4 Antenna Matching and Balun

The **ANT1** and **ANT2** pins provide a balanced RF connection to the antenna. The pins must have a DC path to **VDD_PA**, either through an RF choke or through the center point in a balanced dipole antenna. A load impedance at **ANT1** and **ANT2** of $15\ \Omega + j88\ \Omega$ is recommended for maximum output. A load impedance of $50\ \Omega$ can be obtained by fitting a simple matching network between the load and the **ANT1** and **ANT2** pins. A recommended matching network for $50\ \Omega$ load impedance is described in [chapter 17 on page 51](#).

14.5 DC/DC Converter requirements

The DC/DC converter requires three external components, two inductors and one decoupling capacitor, see [Figure 21. on page 51](#). The inductors should have a low serial resistance ($<1.0\ \Omega$) and must have a maximum DC current rating of at least 50 mA. The capacitors should have low serial resistance.

14.6 PCB layout and decoupling guidelines

A well designed PCB is necessary to achieve good RF performance. A poor layout can lead to loss of performance or functionality. A fully qualified RF-layout for nRF8001 and its surrounding components, including matching networks, can be downloaded from www.nordicsemi.com.

A PCB with a minimum of two layers including a ground plane is recommended for optimum performance. The nRF8002 DC supply voltage should be decoupled as close as possible to the VDD pins with high performance RF capacitors. See the schematics layout in [chapter 17 on page 51](#) for recommended decoupling capacitor values. The nRF8001 supply voltage should be filtered and routed separately from the supply voltages of any digital circuitry.

Long power supply lines on the PCB should be avoided. All device grounds, VDD connections, and VDD bypass capacitors must be connected as close as possible to the nRF8001 IC. For a PCB with a top-side RF ground plane, the VSS pins should be connected directly to the ground plane. For a PCB with a bottom ground plane, the best technique is to have via holes as close as possible to the VSS pads. A minimum of one via hole should be used for each VSS pin.

Full swing digital data or control signals should not be routed close to the crystal or the power supply lines.

15 Mechanical specifications

nRF8001 is packaged in a QFN32 5×5×0.85 mm, 0.5 mm pitch.

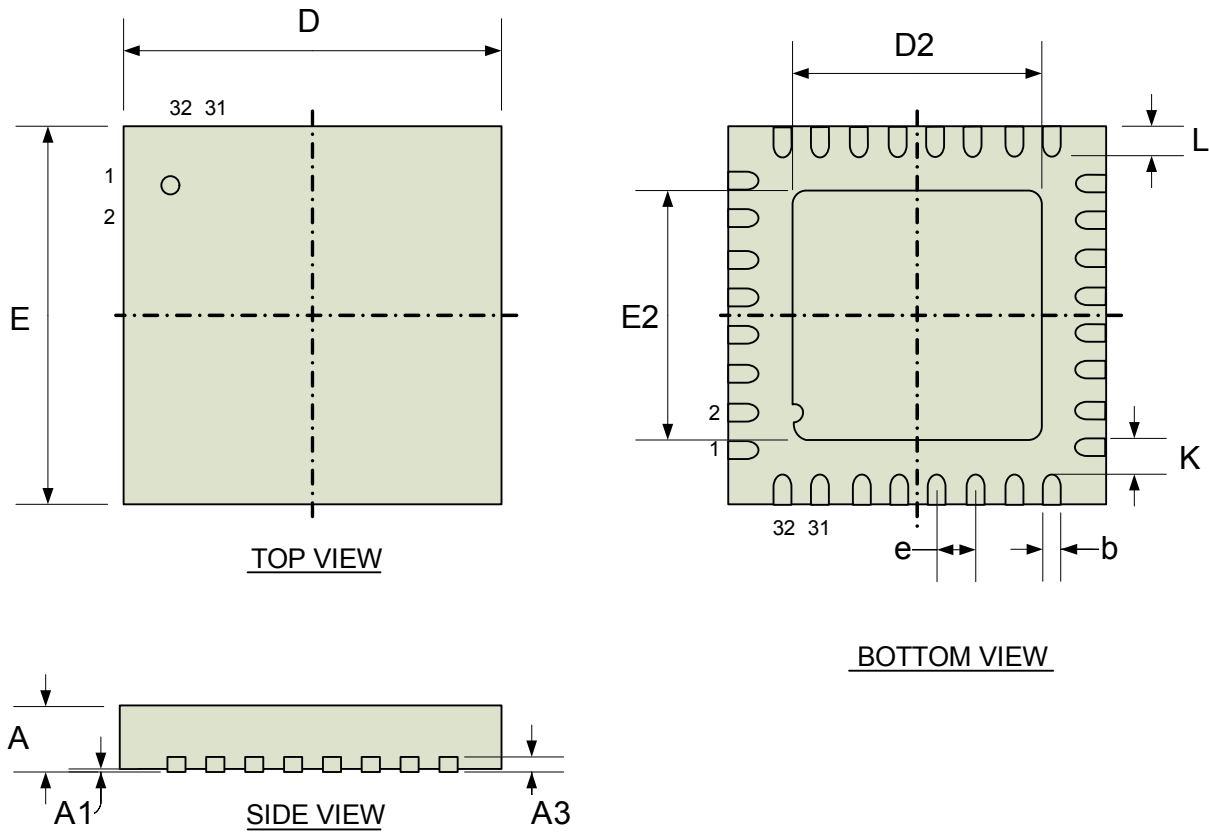

Package	A	A1	A3	b	D, E	D2, E2	e	K	L	
QFN32	0.80	0.00		0.18	4.9	3.50		0.20	0.35	Min
	0.85	0.02	0.20	0.25	5.0	3.60	0.5		0.40	Nom
	0.90	0.05		0.30	5.1	3.70			0.45	Max

Table 20. QFN32 dimensions in mm

16 Ordering information

16.1 Package marking

N	R	F		D	X
8	0	0	1		
Y	Y	W	W	L	L

16.2 Abbreviations

Abbreviation	Definition
8001	Product number
D	Build Code, that is, unique code for production sites, package type and test platform
X	"X" grade, that is, Engineering Samples (optional)
YY	Two-digit year number
WW	Two-digit week number
LL	Two-letter wafer-lot number code

Table 21. Abbreviations

16.3 Product options

16.3.1 RF silicon

Ordering code	Package	Container	MOQ ¹
nRF8001-R2Q32-R	5x5 mm 32-pin QFN, lead free (green)	13" Reel	4000
nRF8001-R2Q32-R7	5x5 mm 32-pin QFN, lead free (green)	7" Reel	1500
nRF8001-R2Q32-T	5x5 mm 32-pin QFN, lead free (green)	Tray	490

1. Minimum Order Quantity

Table 22. nRF8001 RF silicon options

16.3.2 Development tools

Type Number	Description
nRF8001-DK	nRF8001 Development Kit
nRF6700	nRFgo Starter Kit

Table 23. nRF8001 solution options

17 Reference circuitry

17.1 Schematic for nRF8001 with DC/DC converter enabled

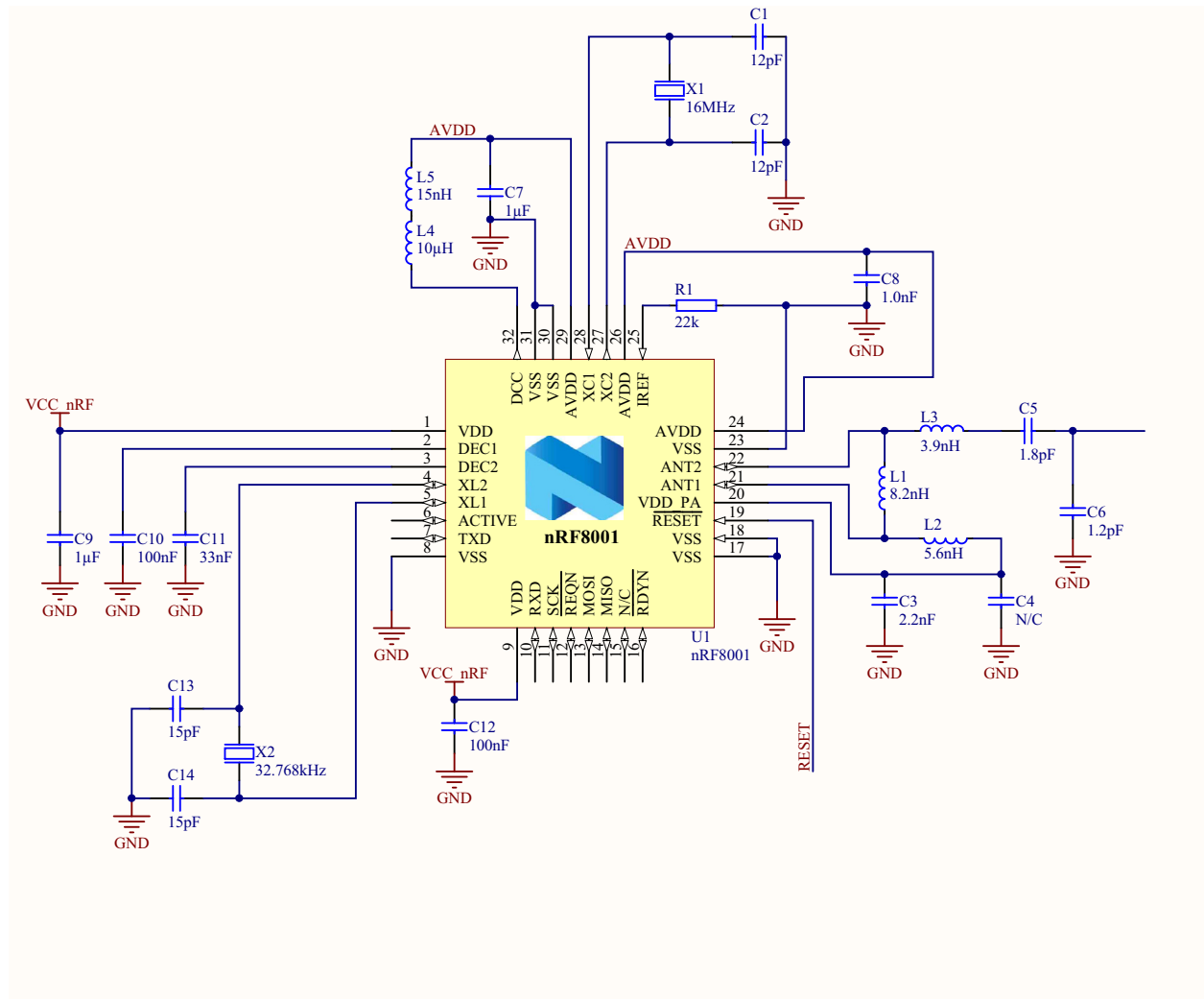
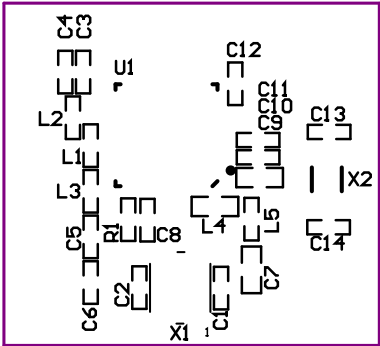
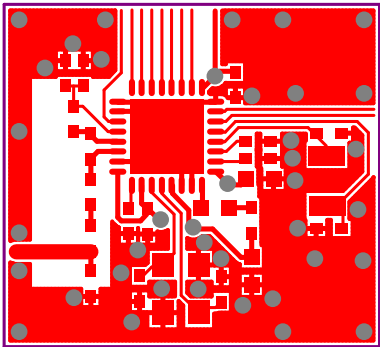
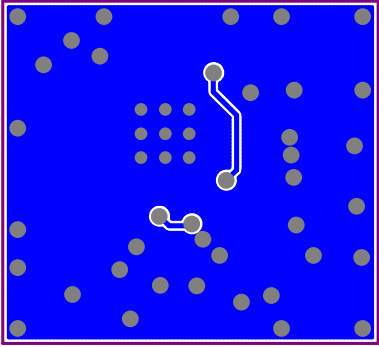

Figure 21. nRF8001 schematic, with DC/DC converter enabled

17.2 Layout

	<p>No components on bottom layer</p>
<p>Top silk screen</p>	
	
<p>Top view</p>	<p>Bottom view</p>

17.3 Bill of Materials

Designator	Value	Footprint	Comment
C1, C2	12 pF	0402	NP0 +/- 2%
C13, C14	15 pF	0402	NP0 +/- 2%
C3	2.2 nF	0402	X7R +/- 10%
C4	NA	0402	Not mounted
C5	1.8 pF	0402	NP0 +/- 0.1 pF
C6	1.2 pF	0402	NP0 +/- 0.1 pF
C7, C9	1.0 μF	0603	X7R +/- 10%
C8	1.0 nF	0402	X7R +/- 10%
C10, C12	100 nF	0402	X7R +/- 10%
C11	33 nF	0402	X7R +/- 10%
L1	8.2 nH	0402	High frequency chip inductor +/- 5%
L2	5.6 nH	0402	High frequency chip inductor +/- 5%
L3	3.9 nH	0402	High frequency chip inductor +/- 5%
L4	10 μH	0603	Chip inductor, I _{DC,min} = 50mA, +/-20%
L5	15 nH	0402	High frequency chip inductor +/- 10%
R1	22 kΩ	0402	+/- 1%
U1	nRF8001	QFN32	QFN32 5×5 mm package
X1	16 MHz	3.2 × 2.5 mm	SMD-3225, 16 MHz, CL=9pF, +/-40 ppm
X2	32.768 kHz	3.2 × 1.5 mm	SMD-3215, 32.768kHz, CI=9pF, ±20 ppm
PCB substrate	FR4 laminate	18.4 × 16.7 mm	2 layer, thickness 1.6 mm

Table 24. Bill of materials, with DC/DC converter enabled

17.4 Schematic for nRF8001 with DC/DC converter disabled

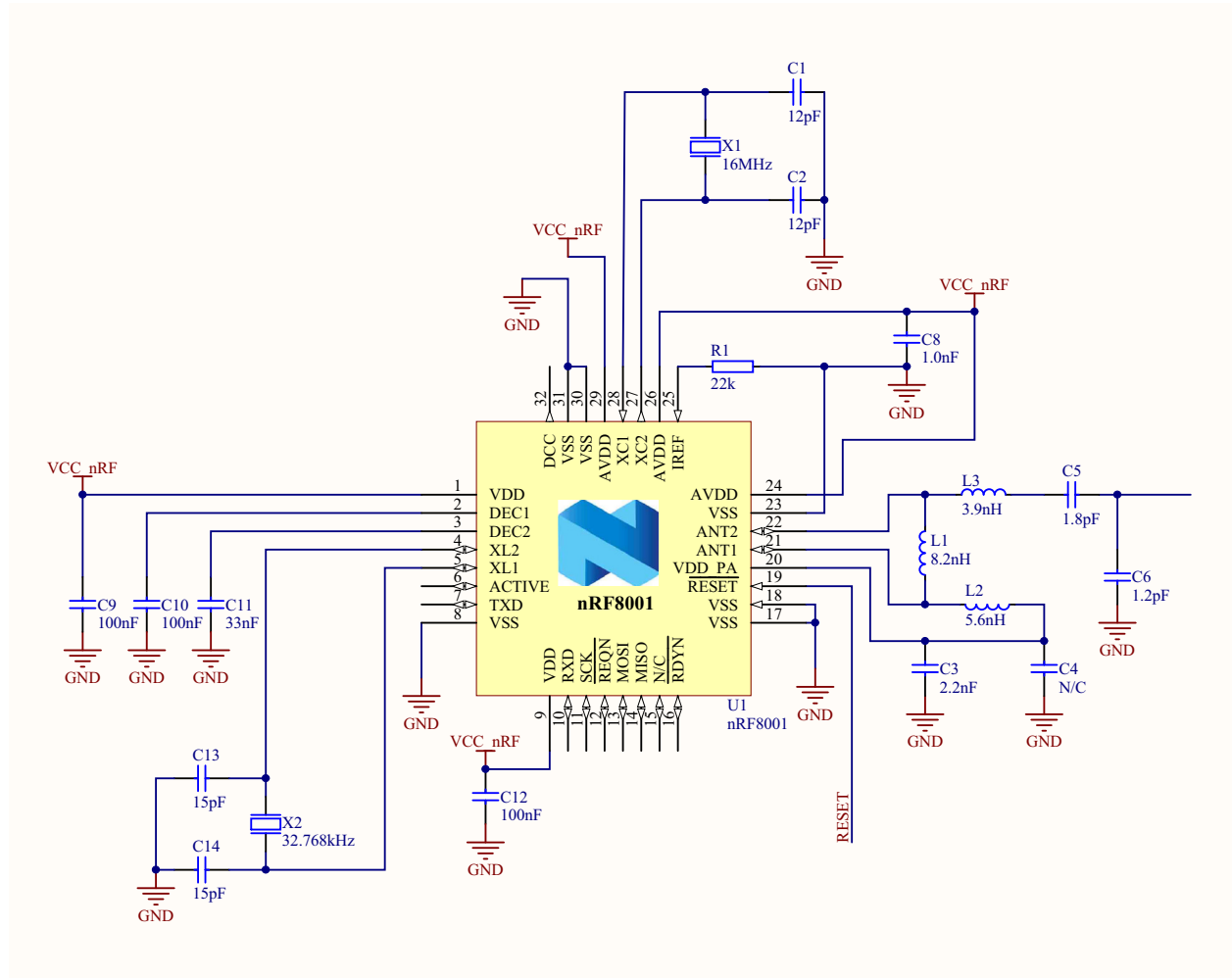
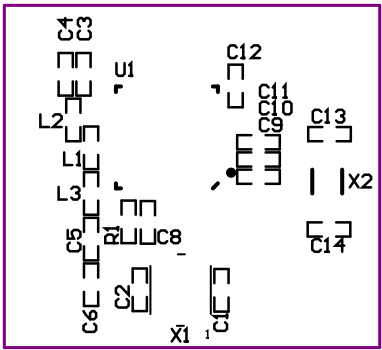
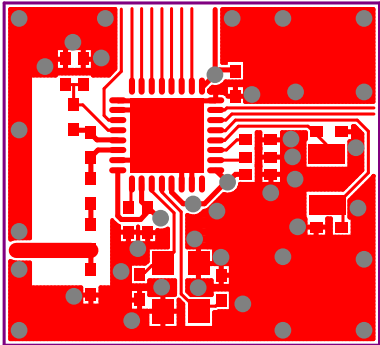
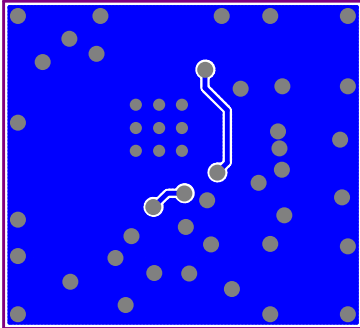

Figure 22. nRF8001 schematic, without DC/DC converter enabled

17.5 Layout

	<p>No components on bottom layer</p>
<p>Top silk screen</p>	
	
<p>Top view</p>	<p>Bottom view</p>

17.6 Bill of Materials

Designator	Value	Footprint	Comment
C1, C2	12 pF	0402	NP0 +/- 2%
C13, C14	15 pF	0402	NP0 +/- 2%
C3	2.2 nF	0402	X7R +/- 10%
C4	NA	0402	Not mounted
C5	1.8 pF	0402	NP0 ±0.1 pF
C6	1.2 pF	0402	NP0 ±0.1 pF
C8	1.0 nF	0402	X7R +/- 10%
C9, C10, C12	100 nF	0402	X7R +/- 10%
C11	33 nF	0402	X7R +/- 10%
L1	8.2 nH	0402	High frequency chip inductor +/- 5%
L2	5.6 nH	0402	High frequency chip inductor +/- 5%
L3	3.9 nH	0402	High frequency chip inductor +/- 5%
R1	22 kΩ	0402	+/- 1%
U1	nRF8001	QFN32	QFN32 5×5 mm package
X1	16 MHz	3.2 × 2.5 mm	SMD-3225, 16 MHz, CL=9pF, +/-40 ppm
X2	32.768 kHz	3.2 × 1.5 mm	SMD-3215, 32.768kHz, CI=9pF, ±20 ppm
PCB substrate	FR4 laminate	18.4 × 16.7 mm	2 layer, thickness 1.6 mm

Table 25. Bill of materials, without DC/DC converter enabled

Part B: The nRF8001 Application Controller Interface (ACI)

The Application Controller Interface (ACI) is a bidirectional serial interface that enables generic application controllers to set up and operate nRF8001. [Figure 23.](#) illustrates how nRF8001 uses the ACI to logically connect to the application controller.

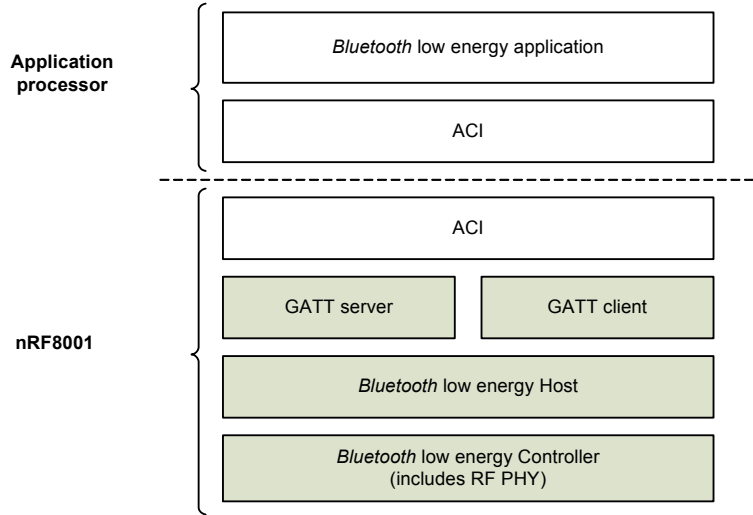

Figure 23. nRF8001 ACI connectivity

18 Operating principle

Figure 24. illustrates the operating principle of the ACI in a typical application.

ACI information traffic is bidirectional; control is exerted by the application controller and nRF8001 responds to ACI commands. nRF8001 may also independently send information to the application controller and all information between the two devices is structured in variable length packets.

Information packets sent from the application controller to nRF8001 are called commands. Commands are classified into two categories; system commands and data commands:

- System commands are commands used for nRF8001 configuration and for operation mode control.
- Data commands are commands that either aim to transfer, or receive, application data when nRF8001 is in a connected state with a peer device.

Information packets sent from nRF8001 to the application controller are called events. Events are classified into two categories; system events and data events.

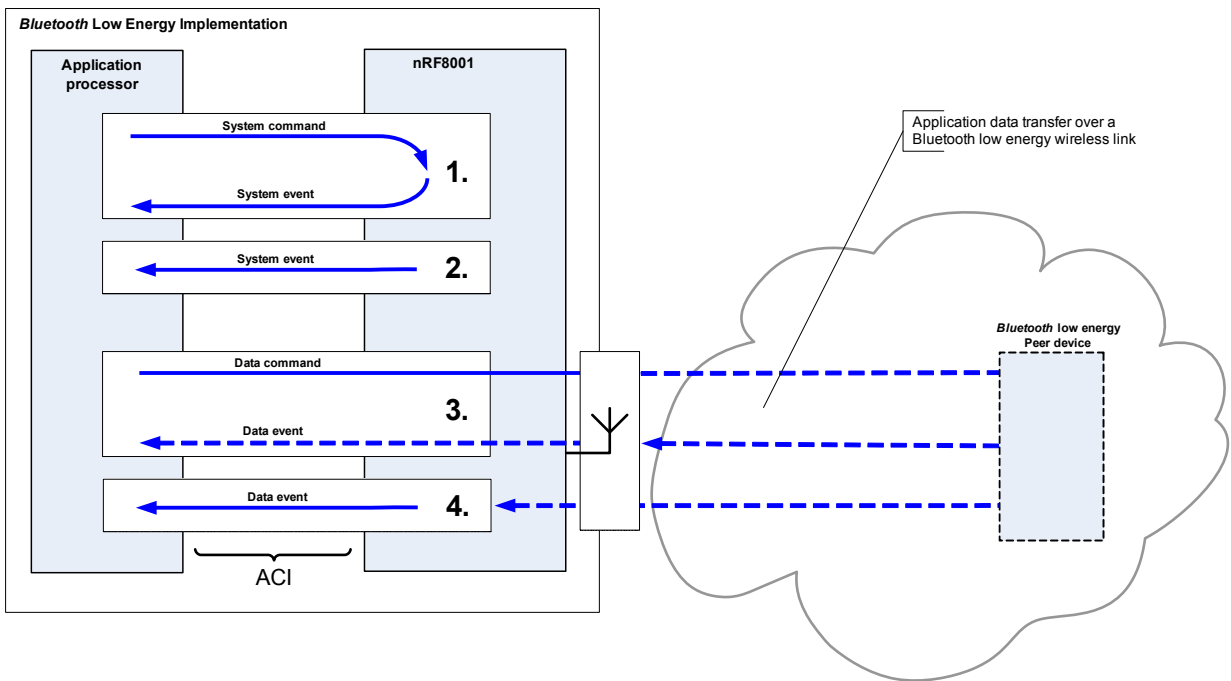

Figure 24. ACI operating principle

Information exchange can be divided into four typical scenarios as illustrated in [Figure 24. on page 56](#)

1. System command – System event
The application controller sends a system command and receives acknowledgment from nRF8001 in the form of an event.
2. System event
nRF8001 sends an event to the application controller triggered by a predefined condition.
3. Data command – Data event
The application controller sends a data command requesting application data transfer or reception. Data is returned in the form of a Data event if the transaction is successful.
4. Data event
nRF8001 sends an event packet to the application controller. This is triggered by a data packet transfer by the peer device or a predefined condition related to application data transfer.

18.1 Packet structure

ACI information traffic is organized in packets. Each packet consists of a 2 byte header field followed by a variable length packet payload.

The byte ordering follows the Little Endian format (Least significant byte transmitted first). In this part of the document capitalized letters as in MSB (Most Significant Byte) indicate bytes.

Text data is transmitted leftmost character first.

For information on bit ordering and description of the ACI physical transport, see [Part A, section 7.1 on page 21](#)

[Figure 25.](#) illustrates the ACI packet.

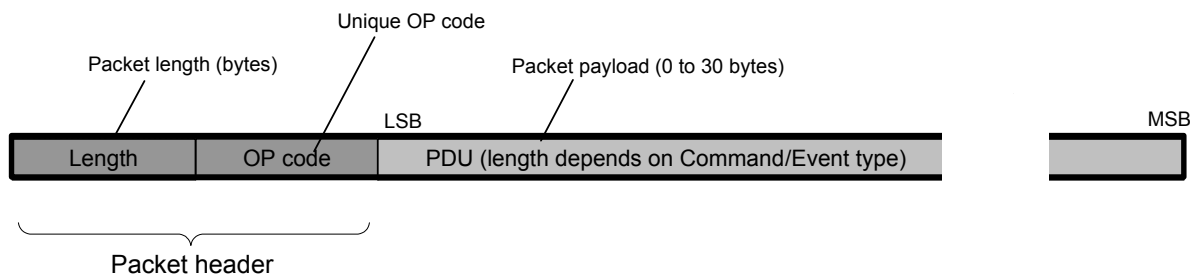

Figure 25. ACI packet structure

The packet header consists of two bytes. The first byte represents the total packet length of the packet (excluding the length field) in bytes. The opcode field contains the unique OP code for the specific command/event.

The PDU length is determined by the ACI packet type. Some ACI packets may have a variable length PDU (Protocol Data Unit) depending on the parameter options for the specific ACI packet.

19 ACI packet types

This chapter defines the packet types sent or received on the ACI.

19.1 System commands

System commands are commands sent by the application controller to nRF8001. These commands control nRF8001 configuration, operating mode and behavior.

19.2 Data commands

Data commands are commands sent by the application controller to nRF8001. Data commands are used when application data traffic exchange between nRF8001 and a peer device is required. Application data is stored in the peer device (remote GATT server), or in nRF8001 (local GATT server).

Data commands initiate data transfer between nRF8001 and the peer device:

- When nRF8001 is acting as a GATT server it can either:
 - Initiate transfer of local application data to the peer device.
 - Receive application data sent from the peer device.
- When nRF8001 is acting as a GATT client it can either:
 - Send application data to the peer device.
 - Request application data to be transmitted from the peer device.
 - Receive application data from the peer device in the form of a **Handle Value Indication** or **Handle Value Notification** message.

Note: The timing of radio traffic is controlled by the *Bluetooth* low energy radio and is thus only indirectly tied to the timing of data commands. For example; data transmission will only occur during the short periodic time slots in a connection interval when the radio is active. Likewise, reception of data will only occur during a connection event if the peer device is able to respond.

19.3 Events

Events are messages sent from nRF8001 to the application controller. Events can be either response events or asynchronous events depending on the triggering factor for the event:

- Response events are direct acknowledgment responses to a command (for example, `CommandResponseEvent`).
- Asynchronous events are messages to the application controller indicating that a condition has occurred. For example, a `DisconnectedEvent` is generated when the RF link has been lost. This may be the result of the peer device moving out of range or having lost power. Similarly receiving data from a peer device will generate a `DataReceivedEvent`. This means that these events have no regular or predictable time relationship to an ACI command.

20 Service pipes

A key activity in a *Bluetooth* low energy application is accessing and exchanging specific application data contained in the Server setup and/or the Client. Application data can be stored locally (stored in the nRF8001) and remotely (stored in the peer device).

20.1 Functional description

In nRF8001, the concept of service pipes¹ is used to simplify access to service characteristics in a Client and/or Server. A service pipe may be considered a data transfer pipe to (or from) a specific characteristic in a Server or Client.

Service pipes point to a specific Characteristic declaration in a Service, for example, the Temperature Characteristic declaration in a Thermometer Service. The value of this Characteristic is transmitted (or received) through the Pipe. Once you have programmed the service pipes configuration into nRF8001, they are static for the lifetime of the application. The type and number of service pipes you need to define is dependant on your application profile requirements. When the application is active, only the application data of interest is sent through the defined service pipes.

The service pipe setup also defines the following:

- Direction of data transfer
 - This is either transmit or receive. A transmit pipe carries data from the application controller to a peer device. A receive pipe carries data from a peer device to the application controller.
- Server location
 - The characteristics value may either be located on the nRF8001 server or on the peer device.
- Acknowledgment requirements
 - The service pipes can be set to require acknowledgment from the peer device that transfers are successful and data is correctly received. A peer device may also require an acknowledgment to be sent from the nRF8001 application controller.
- Auto Acknowledgment
 - The peer device may require an acknowledgment from nRF8001, it is automatically executed by nRF8001 without involving the application controller.
- Link Authentication
 - A connection is authenticated by an encrypted link using LTK (Long Term Key).
- Broadcast
 - Data may be sent in the advertisement packets as defined in *Bluetooth* Specification, Ver. 4.0, Vol. 3, Part C, section 9.1.1. Data may only be sent in connectable advertisement packets or un-connectable advertisement packets using the AD type Service Data, see *Bluetooth* Specification, Ver. 4.0 Vol. 3 Part C section 11.
- Request initiation
 - There are two alternatives for transferring data between nRF8001 and a peer device. Data may either be transmitted from the peer device, or be received by nRF8001 upon it requesting the peer device to send data.

Acknowledgment and Request are service pipe features that you can enable once the characteristics value location and direction of data transfer are defined.

Each service pipe is assigned its unique service pipe number. When application data is sent to (or received from) a service server, the application software uses the service pipe number to map a pipe to a GATT Characteristic UUID and the service pipe features. A Characteristic is always associated with a specific Service UUID.

1. Service pipe is a concept specific for the nRF8001 ACI - it is not a *Bluetooth* concept.

Multiple service pipes can be assigned to a specific characteristic value depending on the application. The transmit and receive service pipes are described in [section 20.4 on page 60](#) and [section 20.5 on page 66](#).

[Figure 26. on page 60](#) illustrates how different service pipes can be assigned to two separate characteristics. Both service pipe 1 and 2 will access the same data, but with different pipe features. Service pipe 3 is linked to a separate characteristics value and has a different feature.

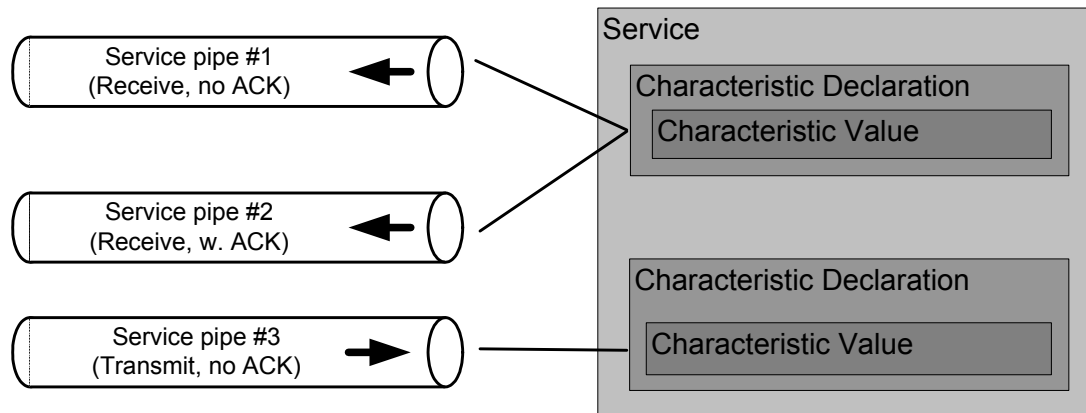

Figure 26. Service pipes assigned to characteristics under a service

20.2 Defining Service pipes

You need to define the services in the local GATT server and the service pipes associated to a remote or local GATT server according to your application requirements and then program them into nRF8001.

nRFgo Studio is a software program that lets you construct the nRF8001 GATT server and define the peer GATT server characteristics required for your application. This program is available on the Nordic Semiconductor website (www.nordicsemi.com) and is used for nRF8001 configuration. nRFgo Studio features predefined services that automatically define and set up the required service pipes.

Once you have defined the service pipes and device setup in nRFgo Studio, the service pipe configuration can be exported and downloaded into nRF8001 using the ACI command `Setup`.

20.3 Data transfer on a service pipe

In normal operating mode, application data transfer is controlled by data commands. The data commands reference the defined service pipes when sending and receiving data. For example, the command `SendData(4, 0xF5)` will send 0xF5 through service pipe number 4. The service pipe number is used to identify the specific Characteristic declaration associated with the transmitted/received data.

To transmit or receive data on a service pipe, the service pipe must be open and the nRF8001 in the connected state. For service pipes associated with a remote GATT server, Service Discovery is automatically executed in order to connect the service pipes.

20.4 Transmit service pipes

Transmit pipes enable the transfer of application data to a peer device. A transmit pipe is associated with a Characteristic declaration and a Characteristic Property defined in the service pipe configuration.

When acknowledgment is enabled, a transmit is acknowledged by the peer device. A `DataAckEvent` is generated by nRF8001 upon receiving the acknowledgment.

[Table 24.](#) lists the available transmit pipe configurations and their functional description.

Characteristic location	Transmit pipe feature		Functional description	Characteristic Property ¹
	Ack	Request		
Local	No	No	<ul style="list-style-type: none"> Update Server and notify Client (Peer device). Notification contains the new Characteristics Value. 	Notify
Local	Yes	No	<ul style="list-style-type: none"> Update Server and send an indication of the update to the Client (Peer device). Peer device acknowledges a successful reception of the indication. nRF8001 generates <code>DataAckEvent</code> 	Indicate
Remote	No	No	<ul style="list-style-type: none"> Transmit data to Server (Peer device). Peer device does not acknowledge data reception.² 	Write without Response
Remote	Yes	No	<ul style="list-style-type: none"> Transmit data to Server (Peer device). Peer device acknowledges a successful data reception. nRF8001 generates <code>DataAckEvent</code>.² 	Write
Local	No	No	<ul style="list-style-type: none"> Broadcast the data using advertising packets. This may be sent on un-connectable and connectable advertisement packets. 	n/a

1. *Bluetooth* specification version 4.0, Vol. 3, Part G, Chapter 4.2

2. Data sent on a remote pipe with acknowledgment followed by data sent on a remote pipe with no acknowledgment may lead to the loss of the `DataAckEvent` generated for the remote pipe with acknowledgment.

Table 26. Transmit pipe feature combinations

20.4.1 Opening a transmit pipe

Transmit pipes and transmit pipes with acknowledge on the local GATT server require opening prior to use. Opening is initiated by the peer device. To open and close the pipes, the peer device writes to the Client Configuration Characteristic Descriptor. For a Transmit Pipe, the peer device sets the Notification bit to open. For a Transmit Pipe with acknowledge, the peer device uses the Indication bit to open and close it, see table 3.11 in the *Bluetooth* specification version 4.0, Vol. 3, Part G, section 3.3.3. Once opened by the peer, the pipe(s) will be listed in the `OpenPipes` bitmap returned by the `PipesStatusEvent`.

[Figure 27. on page 62](#) shows the sequence of events required to open local transmit pipes and local transmit pipes with acknowledge.

SERVICE PIPE – TX or TX-ACK
(Local Store)

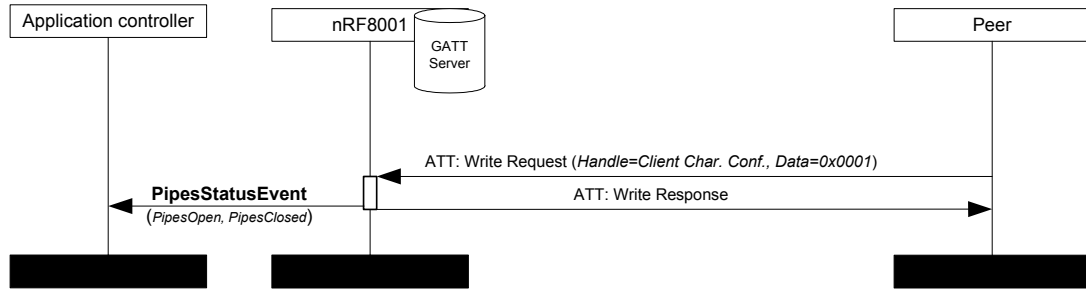

Figure 27. Transmit pipe opening; local data storage

20.4.2 Data transfer on a transmit pipe

Figure 28. through Figure 31. on page 64 shows the successful transfer of data on transmit pipes with and without the acknowledgment feature enabled and with data stored locally and remotely.

SERVICE PIPE - "TX"
(Local Store)

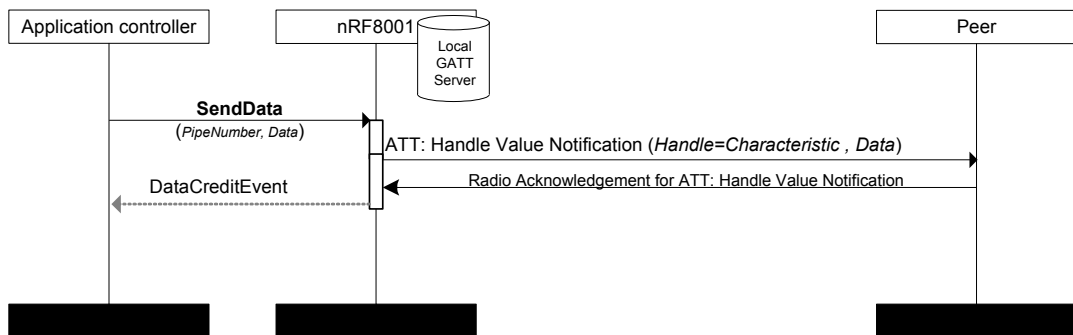

Figure 28. Data transfer on a transmit pipe; data stored locally

SERVICE PIPE - "TX-ACK"
(Local store)

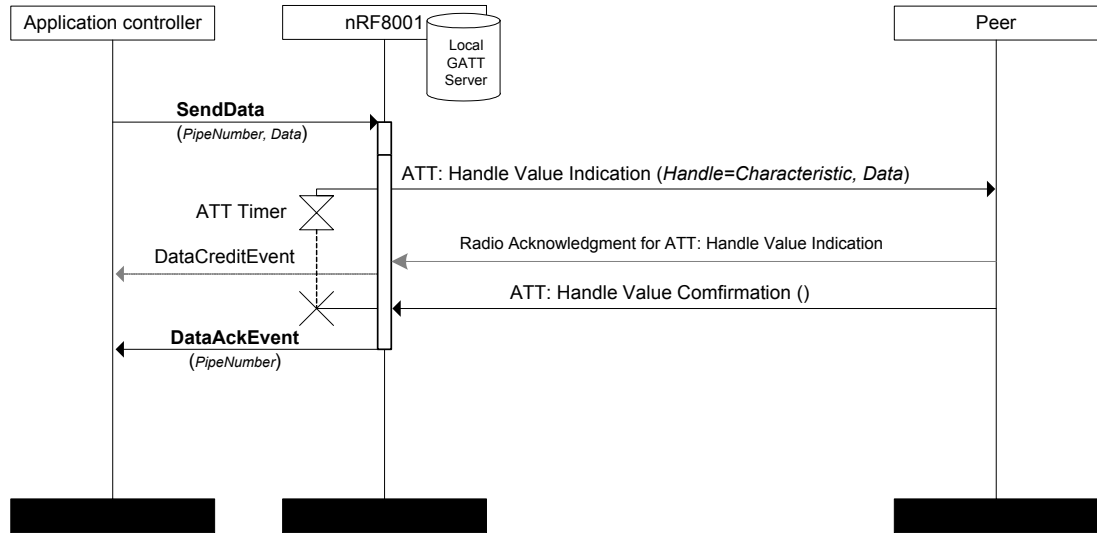

Figure 29. Data transfer on a transmit pipe; acknowledgment enabled and data stored locally

SERVICE PIPE - "TX"
(Remote Store)

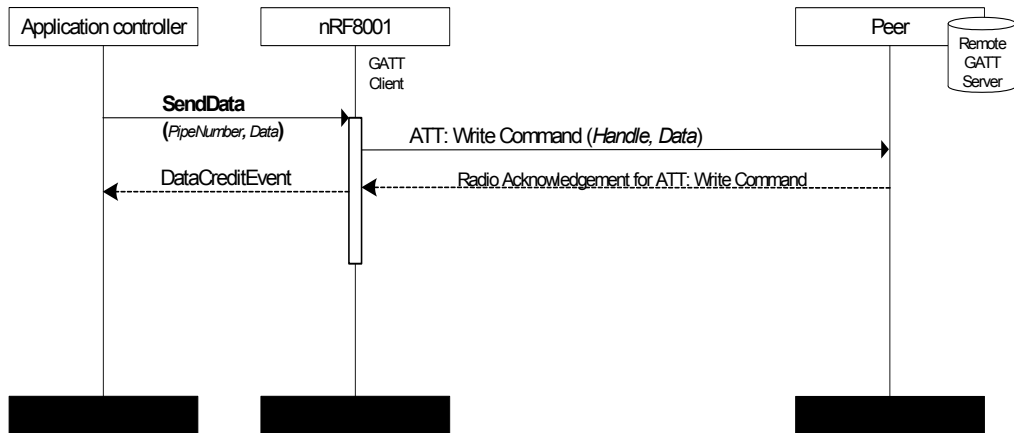

Figure 30. Data transfer on a transmit pipe; data stored remotely

SERVICE PIPE - "TX"
(Remote Store)

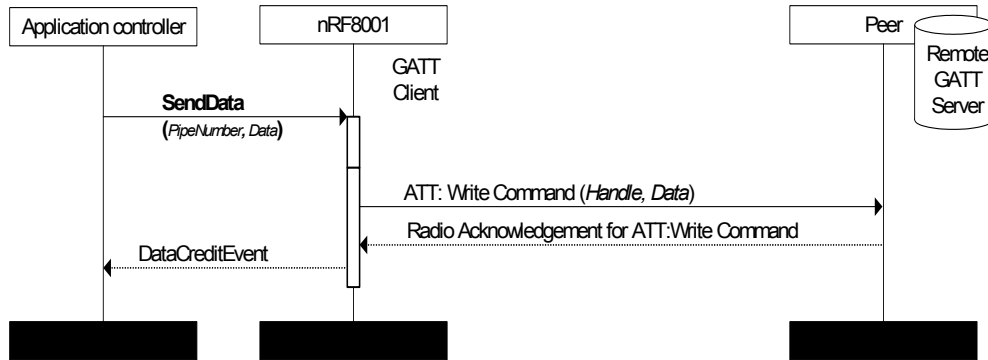

Figure 31. Data transfer on a transmit pipe; acknowledgment enabled and data stored remotely

SERVICE PIPE - "BROADCAST"
(Local Store)

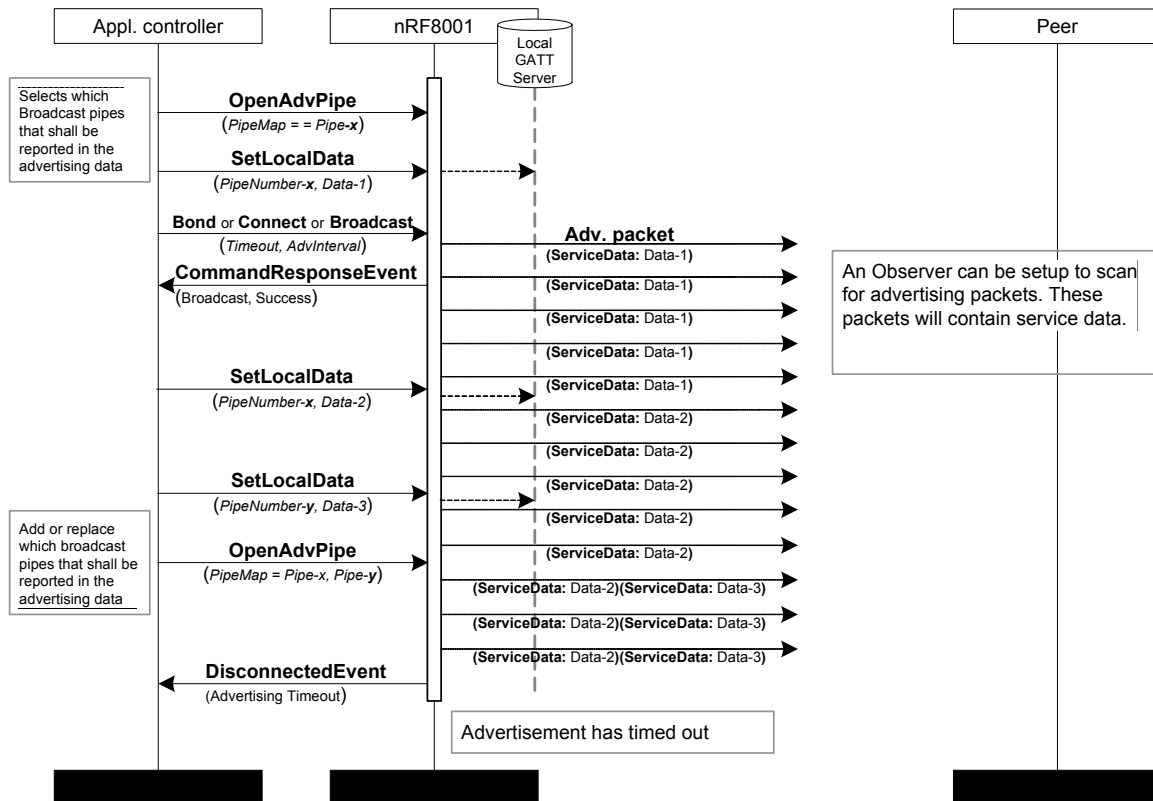

Figure 32. Broadcasting data on a service pipe; data stored locally

20.4.3 Error events

Two events can be issued and returned to the application controller in the case of data transfer failure:

- If the failure is caused by loss of connection, a `DisconnectedEvent` is issued and returned to the application controller.
- If the failure is related to the data transfer, a `PipeErrorEvent` is issued and returned to the application controller.

20.5 Receive service pipes

Receive pipes enable the reception of application data from a peer device. A receive pipe is associated with a Characteristic declaration defined in the service pipe setup. When application data is received from the peer, nRF8001 sends a `DataReceivedEvent` to the application controller.

Acknowledgment and auto acknowledgment may be enabled for receive pipes. When acknowledgment is enabled, the application controller should send an acknowledgment for the `DataReceivedEvent` with the `SendDataAck`. If auto acknowledgment is enabled then nRF8001 will automatically send an acknowledgement to the peer device.

The Request feature must be enabled if nRF8001 is to initiate the data transfer through a Read Request to the remote device.

[Table 25](#) lists the available receive pipe configurations and their functional description. [Figure 33 on page 68](#) and [Figure 35 on page 69](#) show the MSCs applicable for the available feature settings.

Data location	Receive pipe feature		Functional description	Characteristic Property ¹
	Ack	Request		
Local	No	No	<ul style="list-style-type: none"> Receive updates to Server from peer device nRF8001 generates <code>DataReceivedEvent</code> containing the received data. 	Write without response
Local	Yes	No	<ul style="list-style-type: none"> Receive updates to Server from peer device. nRF8001 generates a <code>DataReceivedEvent</code> containing the received data. The application controller acknowledges the Write Request by sending a <code>SendDataAck</code> to nRF8001, this will issue a Write Response to be sent to the peer device. 	Write
Local	Auto	No	<ul style="list-style-type: none"> Receive updates to Server from peer device. nRF8001 generates a <code>DataReceivedEvent</code> containing the received data. nRF8001 will automatically respond to the peer with a Write Response. 	Write
Remote	No	No	<ul style="list-style-type: none"> Receive notification from Server (peer device). Upon receiving the indication, nRF8001 generates a <code>DataReceivedEvent</code> containing the received data. 	Notify
Remote	Yes	No	<ul style="list-style-type: none"> Receive indication from Server (peer device). Upon receiving the indication, nRF8001 generates a <code>DataReceivedEvent</code> containing the updated value. The application controller acknowledges the indication by sending a <code>SendDataAck</code> to nRF8001, this will issue a Handle Value Confirmation to be sent to the peer device. 	Indicate

Data location	Receive pipe feature		Functional description	Characteristic Property ¹
	Ack	Request		
Remote	Auto	No	<ul style="list-style-type: none"> Receive indication from Server (peer device). Upon receiving the indication, nRF8001 generates a <code>DataReceivedEvent</code> containing the updated value. nRF8001 will automatically respond to the peer with a Handle Value Confirmation. 	Indicate
Remote	No	Yes	<ul style="list-style-type: none"> nRF8001 sends a Read Request to the Server (peer device) Peer device responds, returning the requested data. Upon receiving the data, nRF8001 generates a <code>DataReceivedEvent</code>. 	Read

1. *Bluetooth* specification Ver. 4.0, Vol. 3, Part G, Chapter 4.2

Table 27. Receive pipe feature combinations

20.5.1 Opening a receive pipe

Remote receive pipes and remote receive pipes with acknowledge require opening prior to use. Opening is initiated by the application controller (see [section 24.19 on page 119](#) for information on the `OpenRemotePipe` command). Once opened by the application controller, the pipe(s) will be listed in the `OpenPipes` bitmap returned by the `PipesStatusEvent`.

[Figure 33.](#) shows the sequence of events required to open a remote receive pipe.

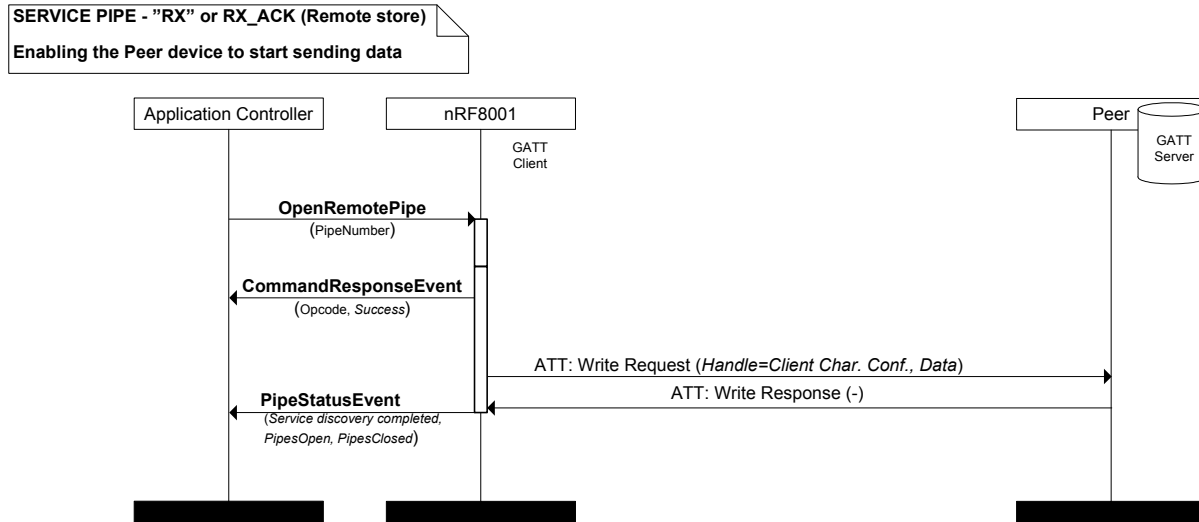

Figure 33. Receive pipe opening; data stored remotely

20.5.2 Closing a receive pipe

Remote receive pipes and remote receive pipes with acknowledge that have been opened may be closed (see [section 24.20 on page 121](#)). Once closed by the application controller, the pipe(s) will be listed in the `ClosePipes` bitmap returned by the `PipesStatusEvent`.

[Figure 34. on page 69](#) shows the sequence of events required to close a remote receive pipe.

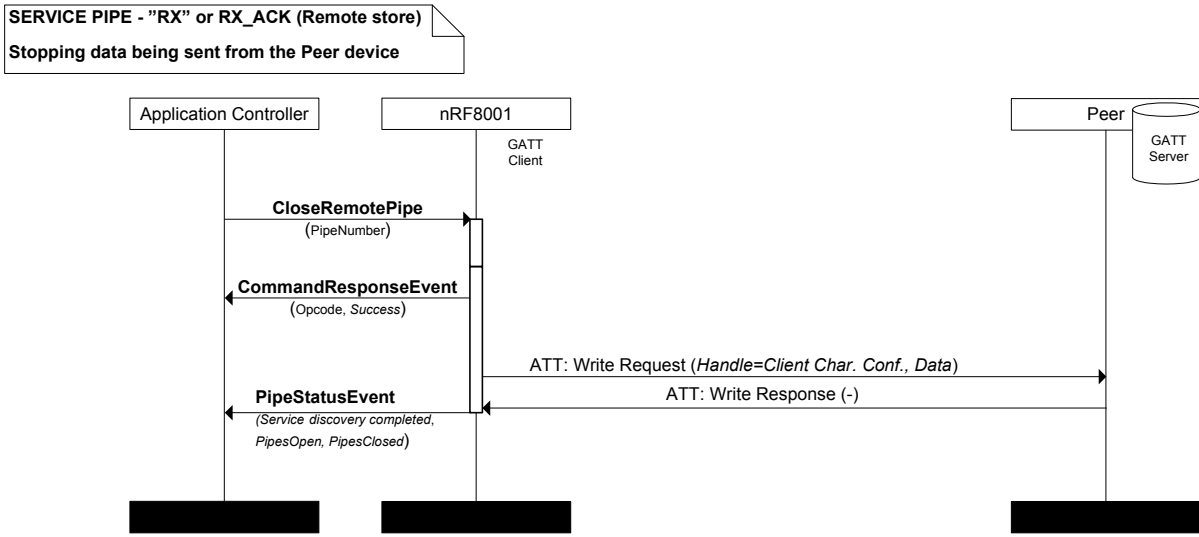

Figure 34. Receive pipe closing; data stored remotely

20.5.3 Data transfer on a receive pipe

The figures in this section show the successful transfer of data on receive pipes with and without the acknowledgment feature enabled and with data stored locally and remotely.

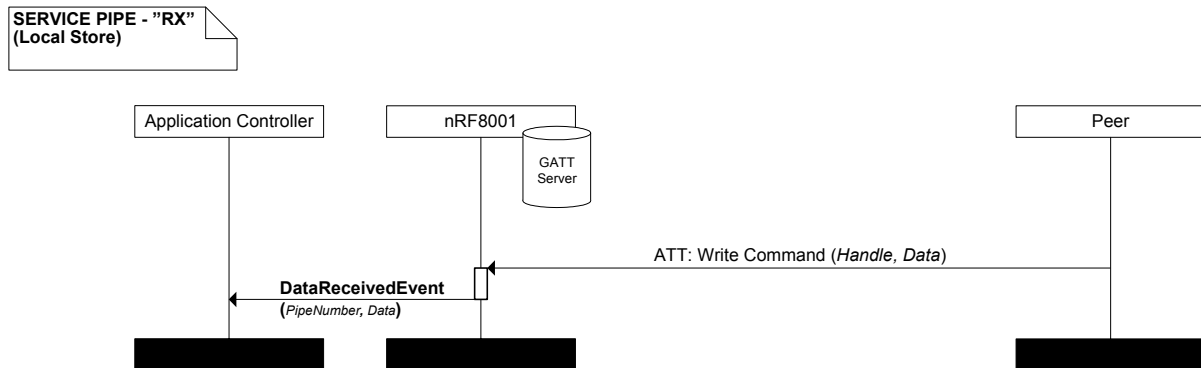

Figure 35. Data transfer on a receive pipe; data stored locally

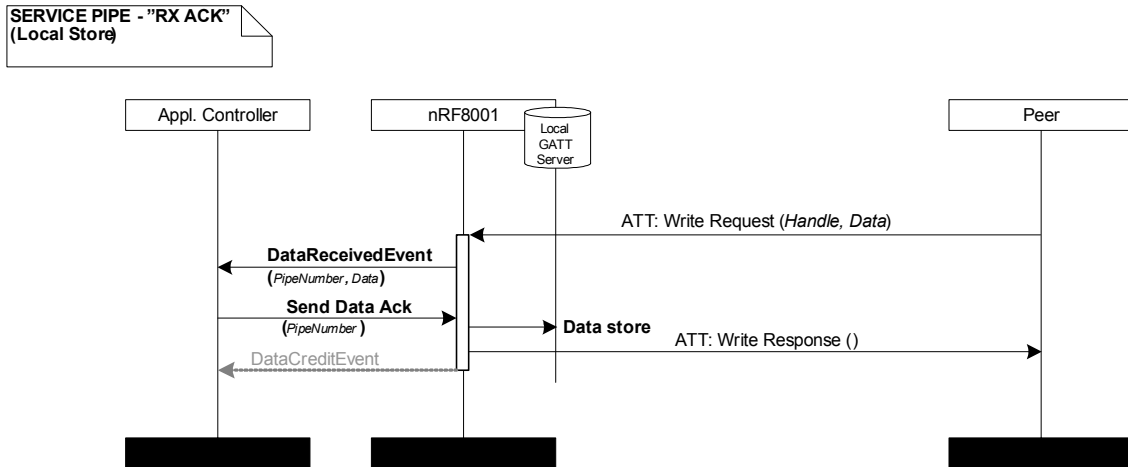

Figure 36. Data transfer on a receive pipe; acknowledgment enabled and data stored locally

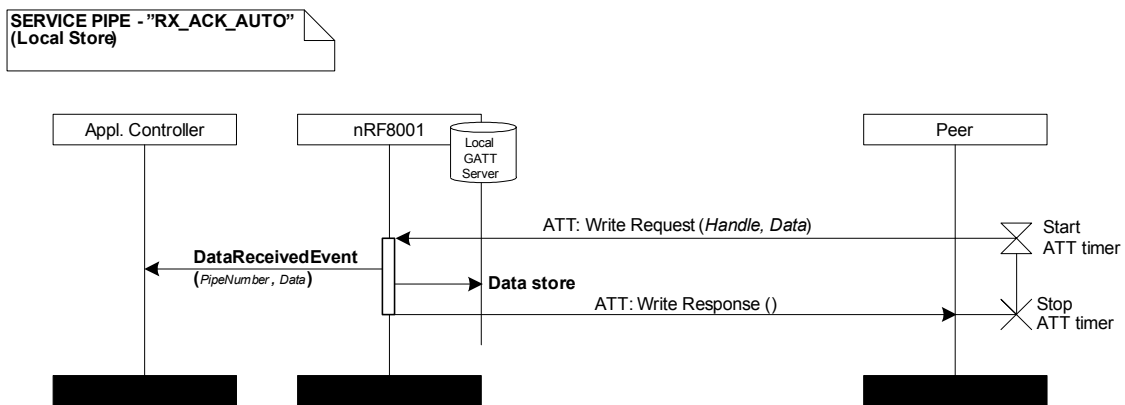

Figure 37. Data transfer on a receive pipe; auto acknowledgment enabled and data stored locally

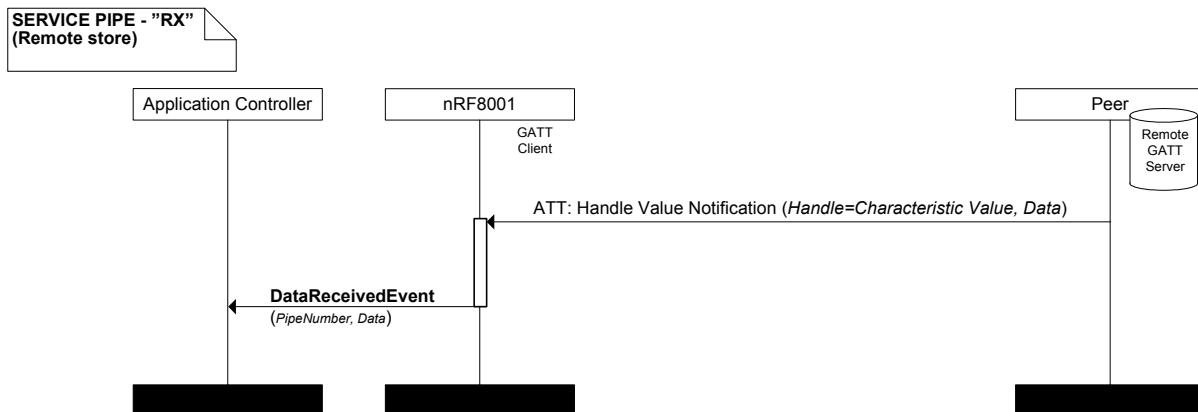

Figure 38. Data transfer on a receive pipe; data stored remotely

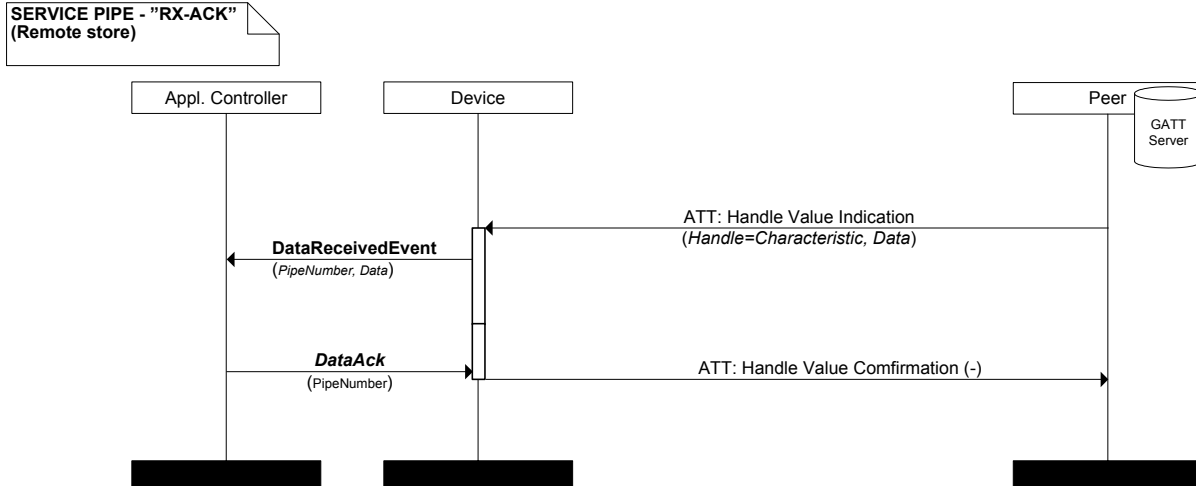

Figure 39. Data transfer on a receive pipe; acknowledgment enabled and data stored remotely

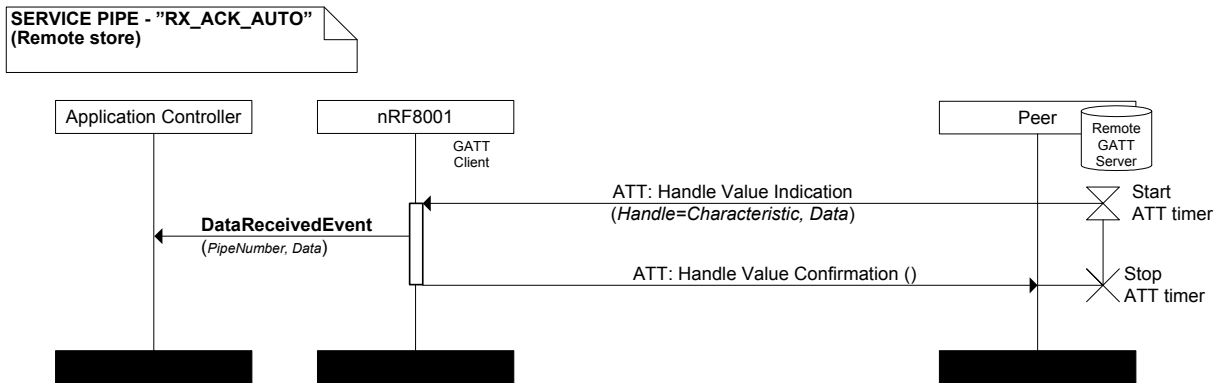

Figure 40. Data transfer on a receive pipe; auto acknowledgment enabled and data stored remotely

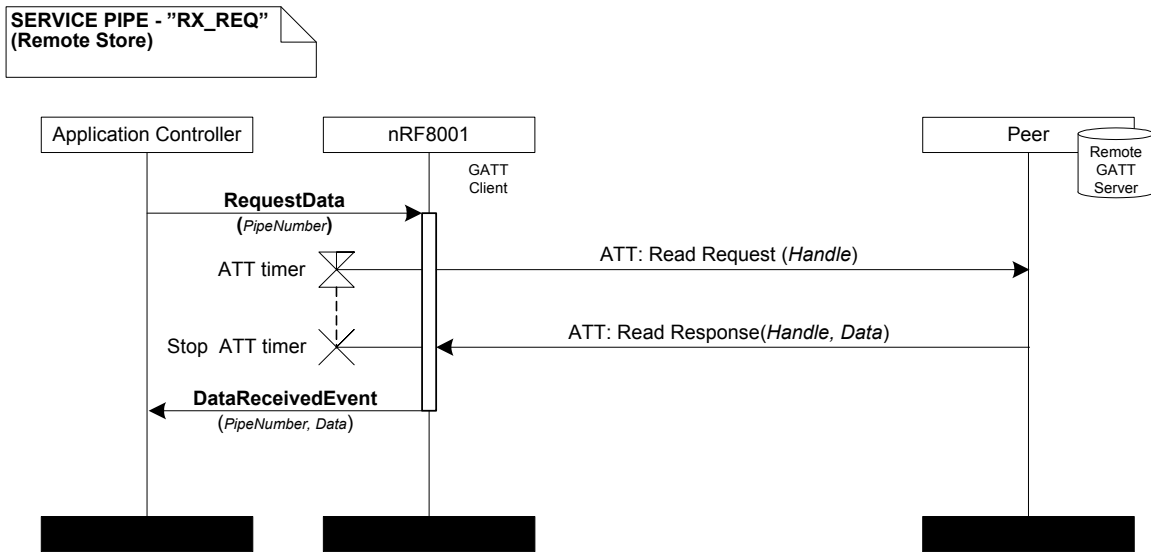

Figure 41. Data transfer on a receive pipe after data request received, data stored remotely

20.5.4 Error events

No error event is ever generated on a receive pipe. In the event of connection loss, a `DisconnectedEvent` is issued and returned to the application controller.

20.6 Service pipe availability

A service pipe to a remote server needs to associate the pipe number to the UUID of a Characteristic, Handle of a Characteristic, and the property of the same Characteristic. This operation is performed in the Service Discovery procedure (see [Section 22.4.2 on page 84](#)). Once the Service Discovery procedure is successfully completed, nRF8001 maps the relationship.

Service pipes need to be listed as available by nRF8001 before data transfer can take place. The pipe availability status is reported to the application controller in the `PipeStatusEvent`.

The `PipeStatusEvent` returns two pipe lists in the form of bitmaps:

- Pipes Open Bitmap: Open pipes where data can be received (or transmitted) without further action.
- Pipes Closed Bitmap: Closed pipes where data can be received only after nRF8001 application controller has instructed the GATT server (peer device) to send data (See [Table 26. on page 65](#)).

The receive pipes identified in the Pipes Closed Bitmap require opening by the application controller using the `OpenRemotePipe` command. The `OpenRemotePipe` command configures the peer device to transmit data on the receive pipe. The opened pipe is then listed in the Pipes Open Bitmap in the following `PipeStatusEvent`.

Transmit pipes that require opening by the peer device (see [Table 26. on page 65](#)) will appear in the Pipes Open Bitmap when nRF8001 has received the instruction from the peer device. A new `PipeStatusEvent` will occur whenever there is a change in the pipe availability status.

21 Flow control

ACI commands received by nRF8001 are executed using the First In, First Out (FIFO) principle. System and Data commands differ in the flow control scheme they enforce:

- System commands must be confirmed as executed by nRF8001 before a new system command can be issued by the application controller. This implies that no system command can be sent before receiving an event from nRF8001 confirming the execution of the previous command.
- Data commands can be queued in a data command buffer pending execution. The application controller must ensure that the number of issued data commands does not overflow the data command buffer.

21.1 System command buffering

Only one System Command can be outstanding at any moment in time before the application controller is allowed to send another one. When the pending system command has executed, nRF8001 issues an event or a sequence of events. See the command descriptions in [chapter 23 on page 89](#) for details.

The application controller must receive an event confirming the execution of the command before sending the next system command.

The response event for a command is sent from nRF8001 within 2 seconds of receiving the command from the application controller.

21.2 Data command buffering

The data command buffer size of nRF8001 is returned in the `DeviceStartedEvent`. The buffer size value represents the maximum number of data commands that may be queued by nRF8001, and is represented by a number of credits granted by nRF8001 to the application controller.

These credits are available for use only after receiving the `ConnectedEvent`. When the `ConnectedEvent` is received, set the number of credits available for use as the value received in "Data Credit Available" in the `DeviceStartedEvent`.

When a data command has been executed on nRF8001, a buffer location is released. Upon release of one or more buffer locations, nRF8001 sends a `DataCreditEvent` to the application controller. The `DataCreditEvent` contains the number of freed buffer locations, called credits. The application controller must keep track of the number of available credits at any time. No assumptions can be made by the application controller as to the timing of credit allowance, as a single `DataCreditEvent` may grant more than one credit. Submitting a data command will subtract one credit from the number of available credits. [Figure 42. on page 75](#) illustrates the flow control and the data credit principle.

If the application controller tries to send a data command when no credit is available, nRF8001 will respond with a `PipeErrorEvent` with its status code set to `ACI_STATUS_ERROR_CREDIT_NOT_AVAILABLE`.

Please note that further restrictions apply related to ATT (Attribute Protocol) flow control, please refer to the *Bluetooth* Specification, Ver. 4.0, Vol. 3, Part F, section 3.3 for details.

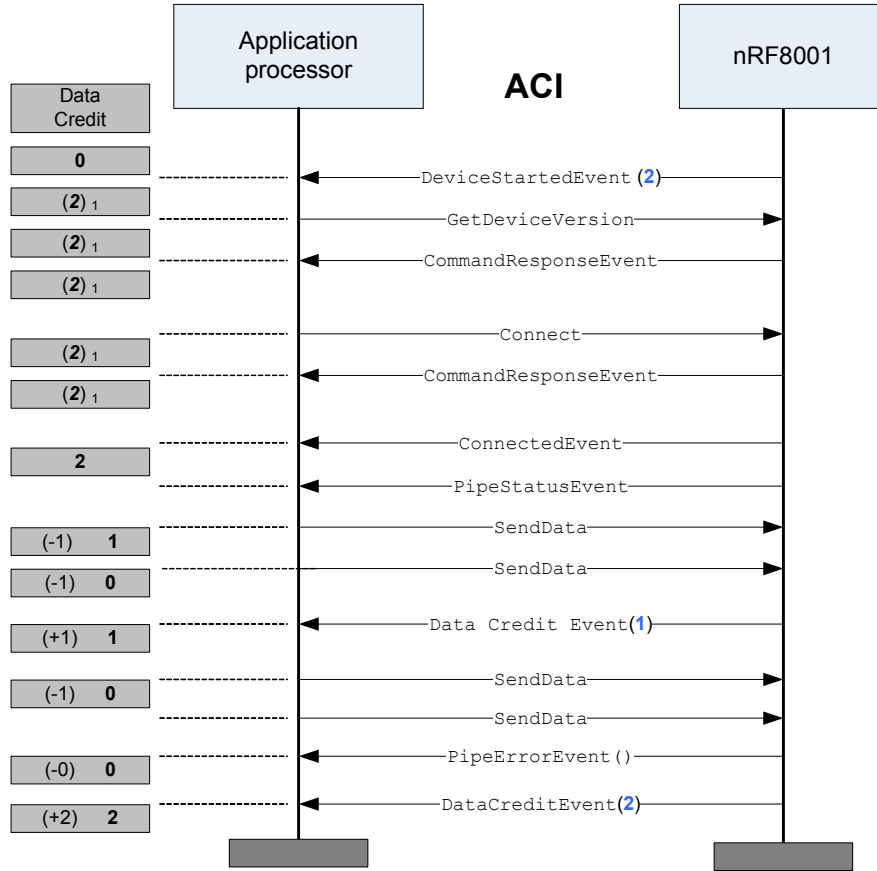

1 : Credits may only be used while connected (after the Connected event)

Figure 42. Flow control example

If no credit event is received within 180 seconds after issuing a data command, then the application controller should issue the disconnect command to recover from this error condition². [Table 28](#) lists relevant ACI commands/events and lists their effect on the data command buffer memory.

ACI Command/Event	Effect on command buffer memory
DeviceStartedEvent	Data service pipes disconnected: No credits can be used
PipeStatusEvent	Data service pipes are connected and in open state: Credits can be used for the service pipes identified as open
DisconnectedEvent	Data pipes disconnected: No credits can be used
DataAckEvent	No effect on buffer memory status
DataCreditEvent (n)	Returns <i>n</i> buffer memory credits to the application controller
DataReceivedEvent	No effect on buffer memory status
SendData	Uses ONE available credit
SendDataAck	Uses ONE available credit
SendDataNack	Uses ONE available credit
RequestData	Uses ONE available credit
OpenRemotePipe	No effect on buffer memory status

Table 28. ACI commands and events affecting command buffer memory credits

2. Data sent over a *Bluetooth* LE link can be No Acknowledged by the peer *Bluetooth* radio infinitely, that is, when data is sent using *SendData/RequestData/SendDataAck*. This is seen on the ACI as a missing Data Credit Event for a *SendData/RequestData/SendDataAck*. The application can disconnect to recover from this condition.

21.3 Flow control initialization

Before ACI commands are issued to nRF8001, the following conditions apply:

- No commands must be sent before the `DeviceStartedEvent` has been received by the application controller.
- Service pipes must be confirmed as open before data commands are issued. No data command shall be sent from the application controller before receiving the first `PipeStatusEvent` containing at least one open pipe.

22 Operational modes

nRF8001 has four modes of operation; Sleep, Setup, Active and Test. The application controller controls the nRF8001 operating modes by means of the ACI commands: *Sleep*, *Wakeup*, *Setup* and *Test*.

Discovered Services and bonding information are retained in all modes except Setup and Test since entering these mode will clear all dynamic data. To flush dynamic data requires a power reset of nRF8001.

22.1 Overview of operational modes

The following is a description of the nRF8001 operational modes:

- **Sleep mode**
 - Power saving mode; all functionality is stopped
 - Stored configuration settings are retained in memory
 - Dynamic data (like bonding information) is stored in memory
- **Setup mode**
 - nRF8001 configuration and setup:
 - GAP configuration
 - GATT service and GATT client configuration
 - Hardware configuration
 - Default operating mode entered upon reset unless setup is stored in NVM
 - All dynamic data is cleared
- **Active mode**
 - Mode used for runtime operation
 - Active mode controls three levels of activity:
 - Connected; nRF8001 is connected to a peer device, data transfer
 - Advertising; nRF8001 is advertising/trying to connect
 - Standby; No radio activity, Idle state
 - Completing the setup sequence puts nRF8001 in active mode
 - Establish a connection with a *Bluetooth* low energy central device
 - Establish a bonded relationship with a *Bluetooth* low energy central device
 - Send and receive data using service pipes
 - Save or restore dynamic data like bonding and pipe status
- **Test mode**
 - Two test features are available: RF PHY and ACI physical connection
 - Direct RF PHY Direct Test Mode (DTM)³ for qualification, test and evaluation of RF PHY layer performance
 - ACI physical connectivity test
 - All dynamic data is cleared

3. *Bluetooth* Specification, Ver. 4.0, Vol. 3, Part F, 'Direct Test Mode'

nRF8001 mode dependencies are illustrated in the state machine chart in [Figure 43](#).

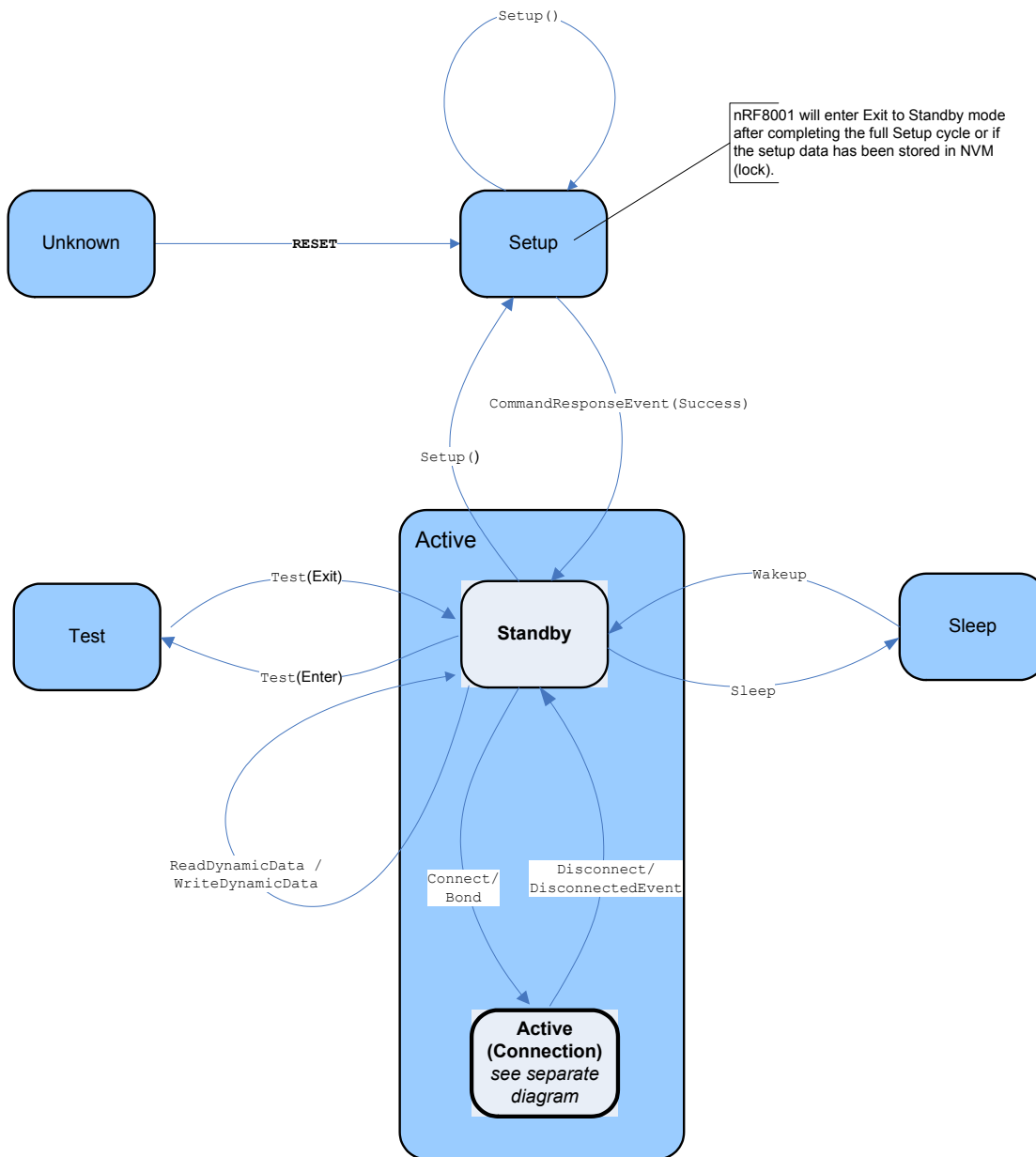

Figure 43. State Machine: Transition between operational modes⁴

Each mode has an associated set of ACI commands and events. An overview of the ACI commands and events applicable to the operational modes is listed in [Table 29. on page 86](#).

4. The state diagram illustrates the normal mode transitions for nRF8001. Note that all possible transitions are not depicted in the figure. For example; it is possible to enter Setup mode from Test mode. See [section 23.1 on page 90](#) and the protocol reference description of the ACI commands `Setup`, `Sleep` and `Test` for details.

22.2 Sleep mode

Sleep mode is used to preserve battery power when nRF8001 is not in a connection or actively broadcasting. Before entering Sleep mode, all connections must be terminated. When in sleep mode, all active connections are disconnected and no features are available. All configuration settings are retained in memory while in Sleep mode. No reconfiguration is required in order to resume normal operation.

The ACI command `Sleep` initiates Sleep mode. Upon receiving the ACI command `WakeUp`, nRF8001 is brought back to Standby mode.

22.3 Setup mode

Setup mode is used for uploading configuration and setup data generated in nRFgo Studio into nRF8001 volatile or non-volatile memory. Once written into non-volatile memory, the configuration is locked and can not be reprogrammed.

nRFgo Studio gives you the option of writing configuration and setup data to volatile and non-volatile memory. This option is intended for use in the application development phase and enables multiple re-writes without having to discard a device upon configuration data updates. Configuration data written to volatile memory will be lost upon reset or power cycling.

nRF8001 setup involves configuration of the following:

- GAP settings
- GATT services
- Hardware settings

Use nRFgo Studio to set up configuration settings. Once you have completed the configuration setup, the configuration can be exported from nRFgo Studio in the form of a set of ACI `Setup` commands. The setup procedure of nRF8001 must be completed before nRF8001 can be used to send or receive data.

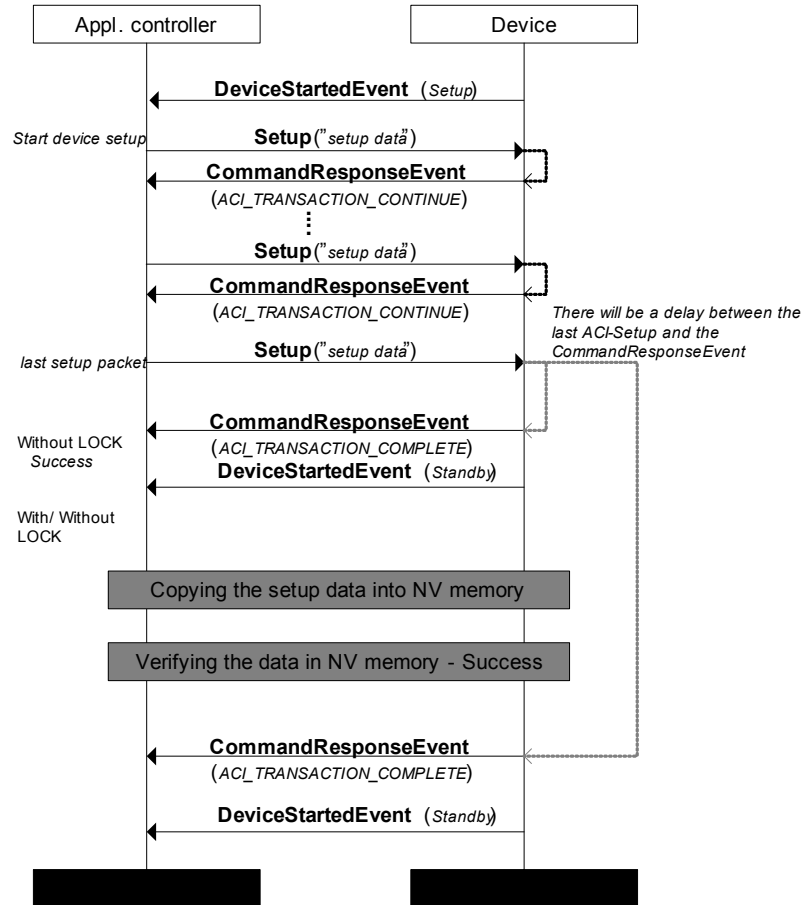

Figure 44. Setup procedure MSC

Note: It takes significantly longer to write to non-volatile memory than to volatile memory. For example, writing 1616 bytes of configuration to volatile memory takes approximately 50 ms, and to non-volatile memory it takes approximately 1.6 seconds.

22.3.1 GAP settings

The GAP settings defines the nRF8001 behaviour in normal operating mode (Active mode) and defines *Bluetooth* low energy specific parameters, such as (but not limited to):

- Device name
- Advertisement packet format and content
- Encryption requirement and key size

22.3.2 GATT services

GATT services represent the configuration of services (and the characteristics grouped under them)⁵ supported by nRF8001 when it acts as a server, and which services to create service pipes to on a peer device, when acting as a client. When implementing a *Bluetooth* low energy profile, the required services are specified in the profile specification.

5. *Bluetooth* specification, Ver. 4.0, Vol. 3, Part G (GATT), Sect. 2.6 and Sect. 3

Setup of GATT services involves configuration of the following:

- Local Services (Server), relevant remote services (Client)
- Applicable service pipes

22.3.2.1 UUID configuration and format

All services and characteristics are identified by a 128 bit Universally Unique Identifier (UUID). Service and Characteristic UUIDs are either defined by the *Bluetooth* SIG or you may define your own.

The UUID's associated with the adopted *Bluetooth* services are listed in the Assigned Numbers document. This document can be downloaded from the *Bluetooth* SIG website: https://www.bluetooth.org/Technical/AssignedNumbers/service_discovery.htm. The format of the *Bluetooth* SIG UUIDs is illustrated in [Figure 45](#).

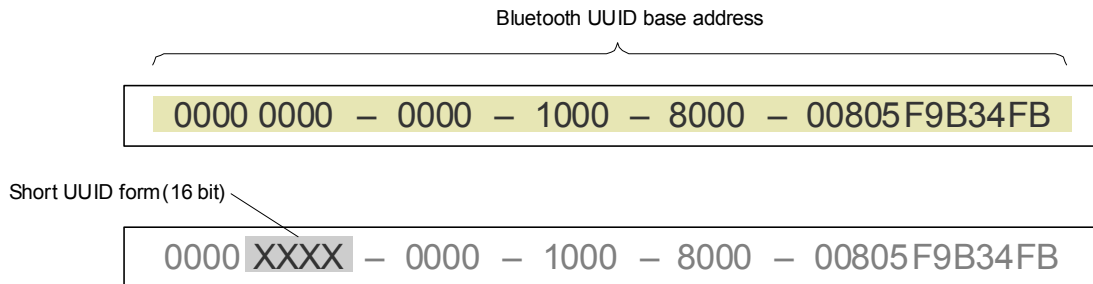

Figure 45. *Bluetooth* UUID format and organisation (Big Endian format)

The characters represented by bytes 13 and 14 are the short form UUID (16 bits rather than the full 128 bit version) which is used to identify the various *Bluetooth* services and characteristics.

If your application requires proprietary services or characteristics, it will use UUIDs that are outside the *Bluetooth* UUID address space.

It is your responsibility to ensure that any proprietary UUIDs you have defined are unique. Visit the International Telecommunication Union (ITU) website for details on the procedure for how to register your own UUIDs: <http://www.itu.int/ITU-T/asn1/uuid.html>.

nRF8001 supports storage of 5 vendor specific 128-bit base UUID that you can specify to any value. Each of the 5 base UUIDs can be further expanded to 65536 UUIDs by changing the 16 bits of the short form UUID, see [Figure 46](#).

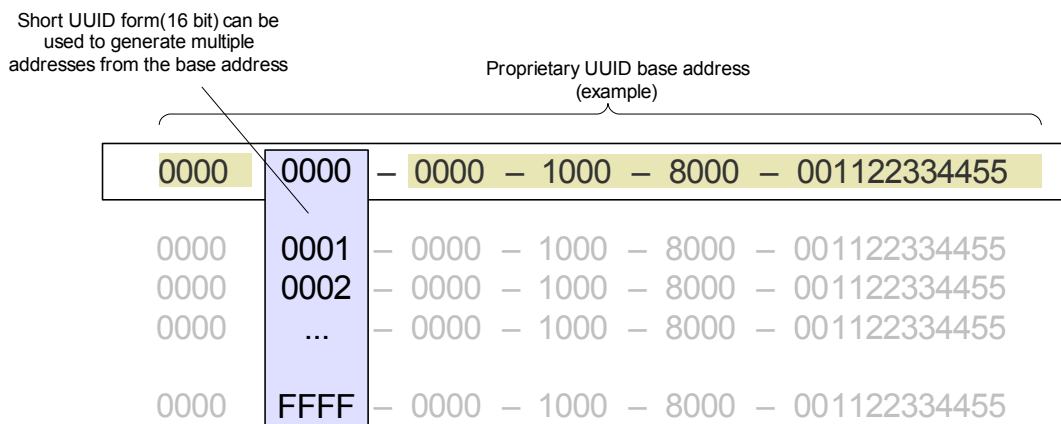

Figure 46. *nRF8001* UUID format and organization

22.3.3 Hardware settings

Hardware settings represent the configuration of proprietary hardware specific parameters, such as:

- Clock sources and settings
- Radio settings
- nRF8001 hardware feature activation and settings (Active signal, antenna EIRP, DC/DC converter and so on)

22.4 Active mode

Active mode handles run time operation and application data exchange. Completing nRF8001 setup is required prior to entering Active mode.

nRF8001 enters Active mode upon completion of the setup procedure, wakeup from sleep mode or directly from reset if the device configuration is stored in Non-Volatile Memory (NVM). nRF8001 exits Active mode upon receiving the ACI commands *Test*, *Setup* or *Sleep*.

Active mode enables the following operations and procedures to be initiated:

- Advertisement including service discovery upon connection establishment
- Bonding
- Sending application data through a transmit service pipe
- Receiving application data through a receive service pipe
- Saving and restoring dynamic data like bonding and pipe connection status

The Active mode state machine diagram is shown in [Figure 47. on page 83](#).

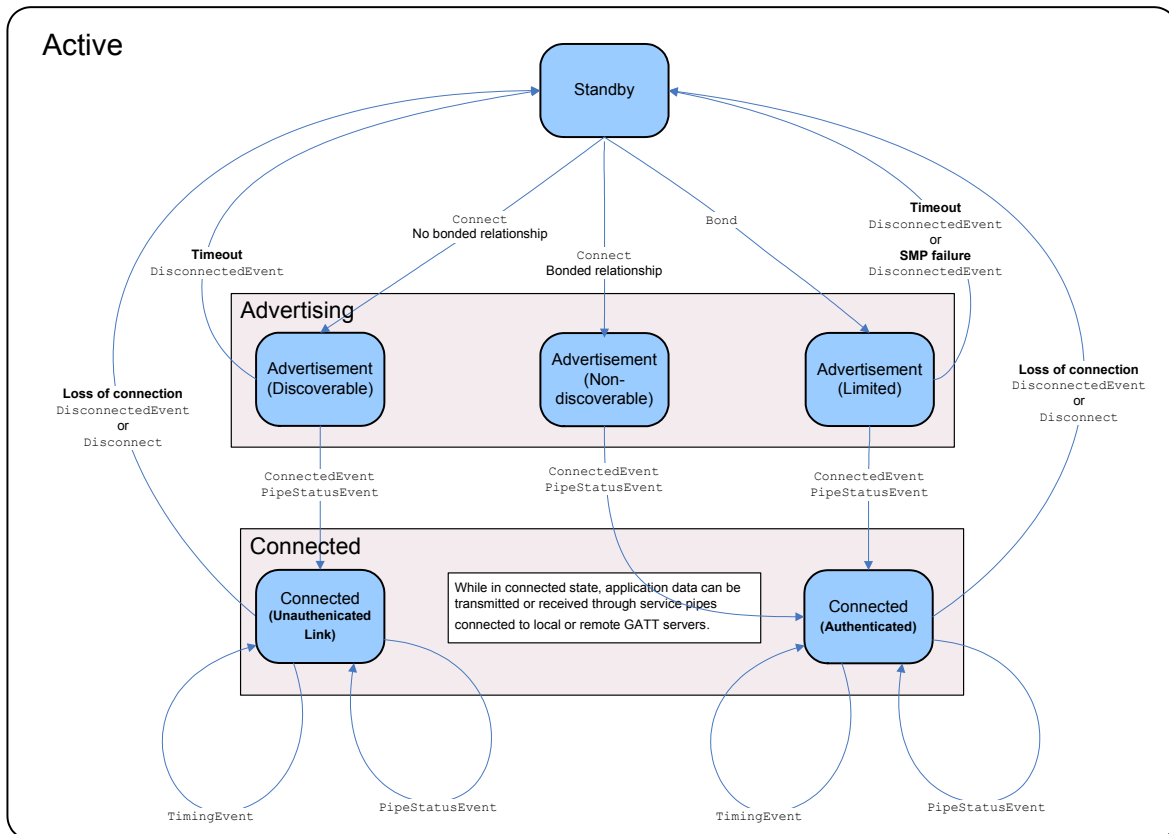

Figure 47. Active mode operation state machine

When in active mode, nRF8001 will start advertising in order to establish a connection to a peer device in the central role upon receiving the ACI commands Connect or Bond. A successful connection results in a transition to the connected state.

Once connected, the nRF8001 initiates the service discovery procedure when required, see [section 22.4.2 on page 84](#) for details.

A timeout value is set for advertising. nRF8001 advertises until a connection has been established, or until the timeout value is exceeded. If nRF8001 successfully connects to a peer device, nRF8001 will remain connected even after the timeout expires.

22.4.1 Advertising and Connection Establishment

While in Active mode, nRF8001 may be set to the following advertising modes;

- General Discoverable mode⁶ (Connect when not bonding)
- Limited Discoverable mode⁷ (Bond)
- Non-Discoverable mode⁸ (Connect when bonded)

In the case of a successful connection establishment, nRF8001 generates a `ConnectedEvent` followed by one or more `PipeStatusEvents`. nRF8001 will remain connected unless disconnected by the peer or by the application controller. The connection may also be lost as a result of the nRF8001 or peer device moving out of range or due to a protocol timeout or failure.

Upon advertisement timeout or connection loss, nRF8001 will return to Standby mode until a new `Bond` or `Connect` command is issued by the application controller.

22.4.2 Service Discovery

The service discovery procedure is initiated automatically upon connection establishment. The discovery procedure discovers the remote services on the peer device that have been defined through the setup procedure, see [section 22.3 on page 80](#). This procedure is required in order to establish the mapping between the pipe number and the remote characteristic attribute. The nRF8001 service discovery procedure activates the following GATT procedures:

- Discover Primary Services by Service UUID⁹
- Discover All Characteristics of a Service¹⁰
- Discover All Characteristic Descriptors¹¹
- Enabling the Service Changed characteristic¹²

Upon execution of the service discovery procedure, a `ConnectedEvent` is generated followed by a `PipeStatusEvent`, returning the service pipe availability status. Multiple `PipeStatusEvents` may result as the pipe availability status is updated during the service discovery procedure.

6. *Bluetooth* specification, Ver. 4, Vol. 3, Part C (GAP), Sect. 9.2.4., General Discoverable Mode

7. *Bluetooth* specification, Ver. 4, Vol. 3, Part C (GAP), Sect. 9.2.3., Limited Discoverable Mode

8. *Bluetooth* specification, Ver. 4, Vol. 3, Part C (GAP), Sect. 9.2.2., Non-Discoverable Mode

9. *Bluetooth* specification, Ver. 4, Vol. 3, Part G (GATT), Sect. 4.4.2., Discover Primary Service by Service UUID

10. *Bluetooth* specification, Ver. 4, Vol. 3, Part G (GATT), Sect. 4.6.1., Discover All Characteristics of a Service

11. *Bluetooth* specification, Ver. 4, Vol. 3, Part G (GATT), Sect. 4.7.1, Discover All Characteristics Descriptors.

12. *Bluetooth* specification, Ver. 4, Vol. 3, Part G (GATT), Sect. 7.1, Service Changed

To minimize power consumption, the nRF8001 service discovery procedure is only executed when the existing pipe mapping is outdated or non-existent. The following conditions will initiate the nRF8001 service discovery procedure:

- the services on the peer device are unknown (that is, when connecting to a new device)
- the nRF8001 is re-connecting to a non-bonded device that contains the **Service Changed** characteristic¹³
- services change while in a connection
- services have changed since last connection (only applicable for a bonded device)

The following applies to the lifetime of service discovery association:

- When bonded, the service discovery information is stored in nRF8001 until the bond is deleted.
- Any existing bond can be deleted by issuing a new `Bond` command or by the peer device.
- If the peer device is not bonded and contains the Service Changed characteristic, the existing service discovery association is lost upon connection loss.
- Upon power loss, Reset or Setup, the service discovery association is lost.

The service discovery association, bonding status and other dynamic data stored in volatile memory can be extracted from nRF8001 using the ACI command `ReadDynamicData`. When stored in the application controller, the same data can be reinstated at any time using the `WriteDynamicData` command.

22.4.3 Sending application data to a peer device

You can send application data using transmit service pipes as defined in [section 20.4 on page 60](#). The application data is sent to a peer device using the command `SendData(Data, ServicePipeNo)`. The application data is transmitted to the peer device at the next available connection event.

If the service pipe is set with acknowledgment, the application controller receives a `DataAckEvent` after a successful data transmission.

22.4.4 Receiving application data from a peer device

You can receive application data using receive service pipes as defined in [section 20.5 on page 66](#). Data is sent on the peer devices initiative. When nRF8001 receives data from a peer device, it will generate a `DataReceivedEvent(Data, ServicePipeNo)`.

You may request the transfer of data stored on the peer device by sending a `RequestData(ServicePipeNo)` command. Upon receiving the requested data from the peer device, nRF8001 generates a `DataReceivedEvent(Data, ServicePipeNo)`.

22.4.5 Bonding

Bonding is the process of exchanging and storing security keys and identity information with a peer device. Bonding is required if the application requires authentication.

The ACI command `Bond` initiates the **Bonding** procedure¹³ with a peer device as described in the *Bluetooth* low energy GAP specification.

When nRF8001 is set to bond using IO capabilities to obtain Man In The Middle (MITM) protection then a `DisplayPasskeyEvent` or a `KeyRequestEvent` is generated.

If the application controller receives a `KeyRequestEvent` it must respond with a `SetKey` command.

13. *Bluetooth* specification, Ver. 4.0, Vol. 3, Part C, Sect. 9.4, Bondable Mode

Once bonded, nRF8001 will generate a `ConnectedEvent` followed by a `BondStatusEvent` and one or more `PipeStatusEvent(s)`.

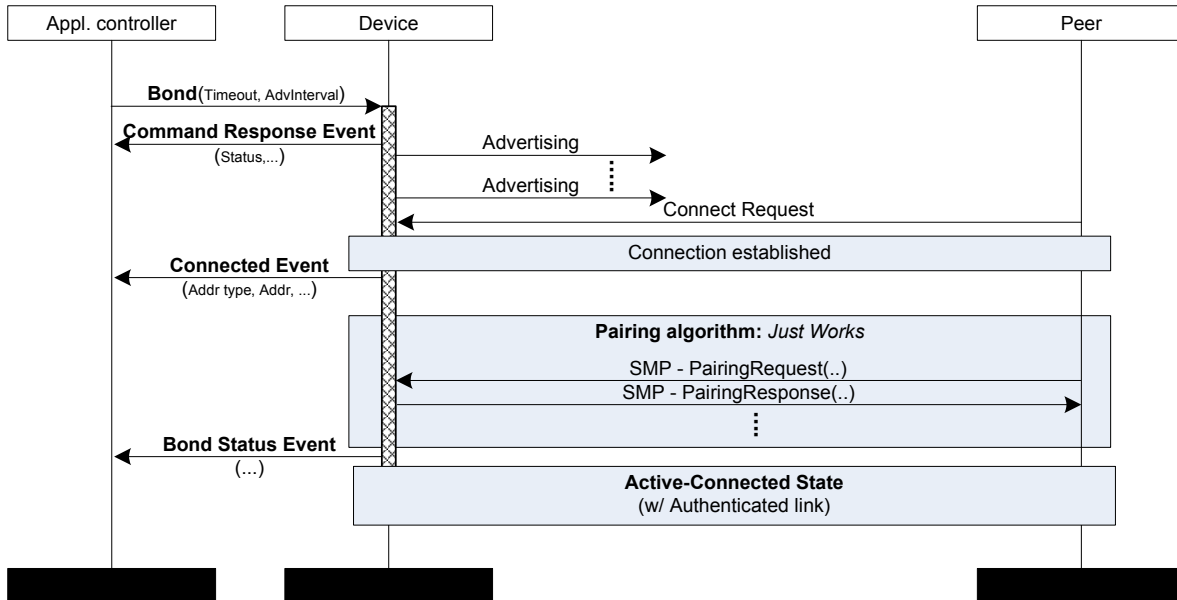

Figure 48. Bonding procedure MSC

Table 29. defines ACI Events and Commands that may be sent in the bonding procedure depending on the local and peer IO capability settings.

IO Capability		ACI Events and Command
nRF8001	Peer device	
None	None	Pairing using Just Work No ACI Events/ Commands involved.
DisplayOnly or Display YesNo	DisplayOnly	Pairing Failed (Only capable of doing Just Work)
	Display YesNo	
	Keyboard	DisplayKeyEvent
	Display & Keyboard	
Keyboard	DisplayOnly	KeyRequestEvent/ SetKey command
	Keyboard	
	Display YesNo	
	Display & Keyboard	
Display & Keyboard	DisplayOnly	KeyRequestEvent/ SetKey command
	Display YesNo	
	Display & Keyboard	
	Keyboard	DisplayKeyEvent

Table 29. Events and Commands sent during bonding procedure

22.4.6 Saving and restoring dynamic data

During normal runtime operation, your nRF8001 application will contain the Attributes and acquire information about peer devices and the services they offer. Your application may also establish a bonded relationship with a peer device. The information your application acquires as a result of normal runtime operation, is stored in nRF8001 as dynamic data. This information is stored in volatile memory and will be

lost if the device is reset or disconnected from the supply voltage, or if the data is overwritten with new dynamic data using the `WriteDynamicData` procedure.

For applications that disconnect the power supply between periods of activity, dynamic data may be stored in the application controller and retrieved when the power supply is restored. This will enable the application to remember the bonding relationship and the pipe availability status valid at the time when the dynamic data was stored.

The ACI command `ReadDynamicData` will extract the dynamic data from nRF8001 for storage in the application controller. After power cycling, the ACI command `WriteDynamicData` can be used to reinstate the stored dynamic data in nRF8001. Note that nRF8001 must contain a valid setup before you read- or write dynamic data to volatile memory.

22.5 Test mode

Test mode is used to test the ACI physical connection and the RF PHY layer of nRF8001.

The ACI command `Test` is used to initiate and exit Test mode.

In test mode, the following test features can be enabled:

- RF PHY testing (*Bluetooth* low energy Direct Test Mode)
- ACI loopback test

While in Test mode, all active connections are disconnected and no device features are available other than the specified test functionality. All nRF8001 dynamic data is lost when entering Test mode.

[Figure 49. on page 87](#) illustrates the test related interfaces and data exchange packets applicable for test mode.

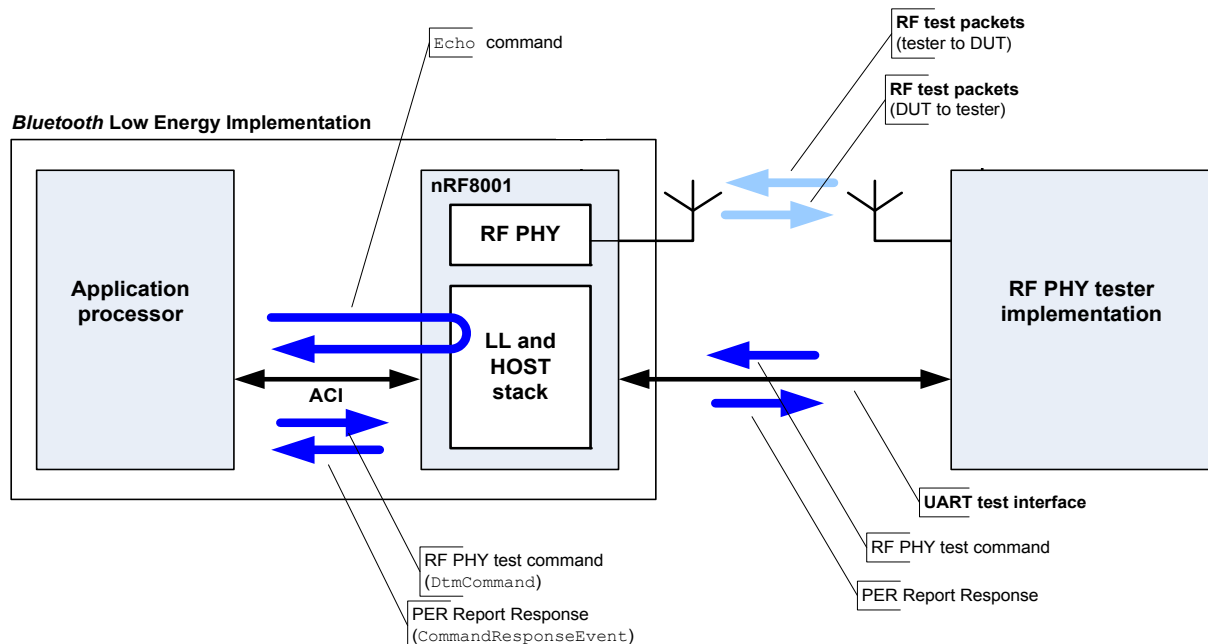

Figure 49. Test interfaces and data exchange in test mode

22.6 RF PHY testing

RF PHY testing can be performed using the UART interface command format as specified in Bluetooth Specification, v. 4.0, Volume 6, Part F, Direct Test Mode. Alternatively, DTM commands can be sent over the ACI using the command `DtmCommand`.

When in Test mode, the RF PHY Direct test mode UART interface is active and can be connected to a validated *Bluetooth* low energy RF PHY tester or to a proprietary RF test system. A proprietary RF tester must implement the Direct Test Mode commands and responses in the defined format¹⁴.

The UART test interface pins and electrical characteristics are described in [Part A, section 5.2 on page 15](#) and [section 7.3 on page 28](#).

22.6.1 Transmitter constant carrier operation

The DTM can also be used to initiate a constant unmodulated carrier mode on the specified RF channel. When initiated, this mode enables easy antenna and matching network tuning.

To initiate the constant carrier mode, the `PKT`¹⁴ field in the LSByte of the DTM command must be set to binary value 11.

22.6.2 ACI loopback test

The ACI command `Echo` is used to test the physical connection of the ACI. Upon receiving the `Echo` command, nRF8001 returns an `EchoEvent` containing the identical content of the `Echo` command to the application controller.

¹⁴. *Bluetooth* specification, Ver. 4.0, Vol. 6, Part F, Section 3.3, 'Commands and Events'

23 Protocol reference

Figure 50. illustrates the required setup and decision process required prior to application data transfer.

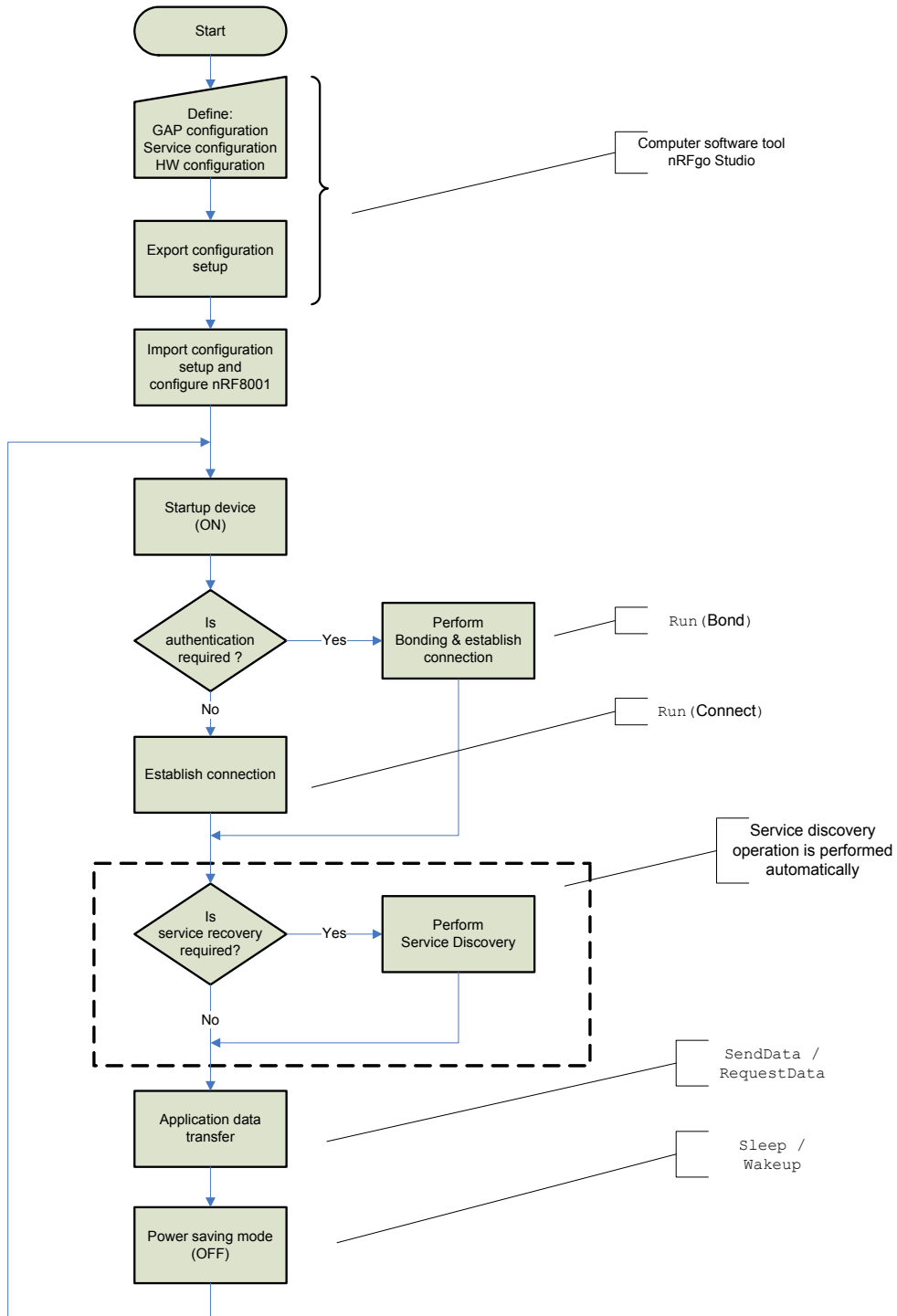

Figure 50. Normal configuration and connection establishment procedure (example)

23.1 Command and event overview

[Table 28](#) shows how the pipe types map to the *Bluetooth* Attribute protocol (see *Bluetooth* Specification, Ver. 4.0, Vol 3, part F).

Pipe type	Local Pipe Action (Characteristic on device)	Remote Pipe Action (Characteristic on peer)
ACI_TX_BROADCAST	Advertisement data	None Allowed
ACI_TX	HV (Handle Value) Notification Sent	Write Command Sent
ACI_TX_ACK	HV Indication Sent	Write Request Sent
ACI_RX	Write Command Received	HV Notification Received
ACI_RX_ACK ^[1]	Write Request received, Deferred Write Response	HV Indication Received
ACI_RX_REQ	Not Allowed	Read Request Sent
ACI_SET	ATTDB value updated	Not Allowed
ACI_RX_ACK_AUTO ^[2]	Write Request received, Immediate Write Response	HV Indication Received, HV Confirmation sent

Table 30. Pipe mapping to ATT

The following table lists the system commands and events that are available and their operating mode dependency:

Packet	Link to relevant section	OP code	Operating mode				
			Setup	Stand by	Active	Sleep	Test
System commands							
Test	Section 24.1 on page 95	0x01	X	X			X
Echo	Section 24.2 on page 96	0x02					X
DtmCommand	Section 24.3 on page 97	0x03					X
Sleep	Section 24.4 on page 99	0x04		X			
WakeUp	Section 24.5 on page 100	0x05				X	
Setup	Section 24.6 on page 101	0x06	X	X			
ReadDynamicData	Section 24.7 on page 102	0x07		X			
WriteDynamicData	Section 24.8 on page 103	0x08		X			
GetDeviceVersion	Section 24.9 on page 105	0x09	X	X	X		X
GetDeviceAddress	Section 24.10 on page 106	0x0A	X	X	X		X
GetBatteryLevel	Section 24.11 on page 107	0x0B	X	X	X		X
GetTemperature	Section 24.12 on page 108	0x0C	X	X	X		X
RadioReset	Section 24.13 on page 109	0x0E		X	X		
Connect	Section 24.14 on page 110	0x0F		X			
Bond	Section 24.15 on page 112	0x10		X			
Disconnect	Section 24.16 on page 114	0x11			X		
SetTxPower	Section 24.17 on page 115	0x12		X	X		
ChangeTimingRequest	Section 24.18 on page 116	0x13			X ¹		
OpenRemotePipe	Section 24.19 on page 119	0x14			X ²		
SetApplicationLatency	Section 24.20 on page 121	0x19			X ²		
SetKey	Section 24.21 on page 123	0x1A			X ³		
OpenAdvPipe	Section 24.22 on page 125	0x1B		X	X		
Broadcast	Section 24.23 on page 127	0x1C		X			
BondSecRequest	Section 24.24 on page 128	0x1D			X ⁴		
DirectedConnect	Section 24.25 on page 129	0x1E		X			

Packet	Link to relevant section	OP code	Operating mode				
			Setup	Stand by	Active	Sleep	Test
CloseRemotePipe	Section 24.26 on page 130	0x1F			X ⁵		
System events							
DeviceStartedEvent	Section 26.1 on page 138	0x81	X	X	X		
EchoEvent	Section 26.2 on page 139	0x82					
HardwareErrorEvent	Section 26.3 on page 140	0x83	X				
CommandResponseEvent	Section 26.4 on page 141	0x84	X	X			
ConnectedEvent	Section 26.5 on page 142	0x85			X		
DisconnectedEvent	Section 26.6 on page 144	0x86			X		
BondStatusEvent	Section 26.7 on page 145	0x87			X		
PipeStatusEvent	Section 26.8 on page 147	0x88			X		
TimingEvent	Section 26.9 on page 150	0x89			X		
DisplayKeyEvent	Section 26.10 on page 151	0x8E			X ⁴ .		
KeyRequestEvent	Section 26.11 on page 152	0x8F			X ⁴ .		

1. Only available after a ConnectedEvent
2. Only available after a ConnectedEvent and the applicable pipe is listed in the PipesClosed bitmap returned in the PipeStatusEvent
3. Valid only as a response to a KeyRequestEvent.
4. Is only generated after a ConnectedEvent while in bonding mode.
5. Only available after the OpenRemotePipe command has been successfully completed.

Table 31. System command/System event operating mode dependency

The following table lists the data commands and events available and their operating mode dependency:

Packet	Link to relevant section	OP code	Operating mode				
			Setup	Standby	Active	Sleep	Test
Data commands							
SetLocalData	Section 25.1 on page 132	0x0D		X	X		
SendData	Section 25.2 on page 134	0x15			X ¹		
SendDataAck	Section 25.3 on page 135	0x16			X ²		
RequestData	Section 25.4 on page 136	0x17			X ²		
SendDataNack	Section 25.5 on page 137	0x18			X ² .		
Data events							
DataCreditEvent	Section 27.1 on page 153	0x8A			X		
DataAckEvent	Section 27.4 on page 156	0x8B			X		
DataReceivedEvent	Section 27.3 on page 155	0x8C			X		
PipeErrorEvent	Section 27.2 on page 154	0x8D		X	X		

1. Only available after a ConnectedEvent and the applicable pipe is listed in the PipesOpen bitmap returned in the PipeStatusEvent
2. Only available after a ConnectedEvent and as a response to a DataReceivedEvent

Table 32. Data command/Data event operating mode dependency

Command	Header		Parameter	Relevant Events
	OP code	length		
Test	0x01	2	• TestFeature (1)	DeviceStartedEvent
Sleep	0x04	1		
GetDeviceVersion	0x09	1		CommandResponseEvent
Echo	0x02	1..30	• Data (0..29)	EchoEvent
Wakeup	0x05	1		DeviceStartedEvent CommandResponseEvent
GetBatteryLevel	0x0B	1		CommandResponseEvent
GetTemperature	0x0C	1		CommandResponseEvent
Setup	0x06	2..31	• SetupData (1..30)	CommandResponseEvent DeviceStartedEvent
SetTxPower	0x12	2	• RadioTransmitPowerLevel (1)	CommandResponseEvent
GetDeviceAddress	0x0A	1		CommandResponseEvent
Connect	0x0F	5	• Timeout (2) • AdvInterval (2)	Successful connection: CommandResponseEvent ConnectedEvent PipeStatusEvent (s) Failed Connection: CommandResponseEvent DisconnectedEvent
Bond	0x10	5	• Timeout (2) • AdvInterval (2)	Successful connection: CommandResponseEvent ConnectedEvent BondStatusEvent Failed Connection: CommandResponseEvent ConnectedEvent (opt) DisconnectedEvent
Disconnect	0x11	2	• Reason (1)	CommandResponseEvent DisconnectedEvent
ChangeTimingRequest	0x13	1/9	• IntervalMin (2) • IntervalMax (2) • SlaveLatency (2) • Timeput (2)	Successful timing change: CommandResponseEvent TimingEvent Failed Connection: CommandResponseEvent DisconnectedEvent
OpenRemotePipe	0x14	2	• ServicePipeNumber (1)	Successful opening: CommandResponseEvent PipeStatusEvent Failed opening: CommandResponseEvent PipeErrorEvent

Command	Header		Parameter	Relevant Events
	OP code	length		
DtmCommand	0x03	3	• DtmCommand (2)	CommandResponseEvent
ReadDynamicData	0x07	1	•	CommandResponseEvent
WriteDynamicData	0x08	3..29	• Sequence Number (1) • SetupData (1..27)	CommandResponseEvent
RadioReset	0x0E	1		CommandResponseEvent
SetApplicationLatency	0x19	4	• Latency mode • Latency number	CommandResponseEvent
SetKey	0x1A	2 or 8	• Key type • Key (0 or 6 bytes)	CommandResponseEvent
OpenAdvPipe	0x1B	9	• Adv Service Data Pipes	CommandResponseEvent
BondSecRequest	0x1D	1		CommandResponseEvent
DirectedConnect	0x1E	1		CommandResponseEvent

Table 33. System commands format overview

Command	Header		Parameter	Relevant Events
	OP code	length		
SendData	0x15	2..22	<ul style="list-style-type: none"> ServicePipeNumber (1) Data (1..20) 	Successful transfer: DataCreditEvent (DataAckEvent) ¹ Failed transfer: DataCreditEvent PipeErrorEvent
RequestData	0x17	2	<ul style="list-style-type: none"> ServicePipeNumber (1) 	Successful reception: DataReceivedEvent Failed transfer: PipeErrorEvent
SetLocalData	0x0D	3..22	<ul style="list-style-type: none"> ServicePipeNumber (1) Data (1..20) 	CommandResponseEvent
SendDataAck	0x16	2	<ul style="list-style-type: none"> ServicePipeNumber (1) 	DataCreditEvent
SendDataNack	0x18	3	<ul style="list-style-type: none"> ServicePipeNumber (1) Error code 	DataCreditEvent

1. In case of the acknowledge feature being enabled on the service pipe

Table 34. Data commands format overview

24 System commands

System commands are commands used for nRF8001 configuration, operation mode control and runtime operations.

24.1 Test (0x01)

Test enables (or disables) the nRF8001 test mode.

24.1.1 Functional description

When in test mode, Direct Test Mode is enabled and ready to receive test commands as specified in the *Bluetooth* Specification, Ver. 4.0, Vol. 6, Part F, 'Direct Test Mode'. The physical test interface can be UART or ACI. Refer to [section 22.5 on page 87](#) and [section 25 on page 132](#) for details. The ACI physical interface may be tested using the command `Echo` (see [section 24.10 on page 106](#)). Upon entering and exiting Test mode, nRF8001 is reset. See the operating mode during which this command can be used in [Table 31. on page 91](#). The command will return a command response event with status `ACI_STATUS_ERROR_DEVICE_STATE_INVALID` when it is used in the incorrect mode.

24.1.2 Message format

Message field/parameter	Value size (bytes)	Data value	Description
Header			
Length	1	2	Packet length
Command	1	0x01	Test
Content			
<i>TestFeature</i>	1		Test feature to activate

Table 35. ACI message structure for Test

24.1.3 Accepted values

Parameter	Data value	Description
<i>TestFeature</i>	0x01	Enable DTM over UART interface
	0x02	Enable DTM over ACI
	0xFF	Exit test mode

Table 36. Accepted values for parameters, Test

24.1.4 Returned events

A `DeviceStartedEvent` is returned indicating that nRF8001 has entered or exited test mode. A `CommandResponseEvent` will result in case of failing to enter or exit Test mode.

24.1.5 Bluetooth low energy procedures used

This command invokes the *Bluetooth* low energy direct test mode functionality for further details, see *Bluetooth* Specification, v4.0, Volume 6, Part F, Direct Test Mode.

24.2 Echo (0x02)

Echo (0x0E) tests the nRF8001 ACI transport layer.

24.2.1 Functional description

Upon receiving an `Echo` command, nRF8001 returns an `EchoEvent` containing the identical command packet data to the application controller.

The reception of a loopback packet confirms a working ACI transport layer.

See the operating mode during which this command can be used in [Table 31. on page 91](#). The command will return a command response event with status `ACI_STATUS_ERROR_DEVICE_STATE_INVALID` when it is used in the incorrect mode.

24.2.2 Message format

Message field/parameter	Value size (bytes)	Data value	Description
Header			
Length	1	1..30	Packet length
Command	1	0x02	Echo
Content			
Data	0..29		Any data

Table 37. ACI message format for Echo

24.2.3 Accepted values

Any value from 0..29 bytes is accepted for this command.

24.2.4 Returned events

This command returns an `EchoEvent`.

24.2.5 *Bluetooth* low energy procedures used

None

24.3 DtmCommand (0x03)

DtmCommand sends a Direct Test Mode command to the radio module through the ACI interface.

24.3.1 Functional description

This command allows DTM control through the ACI, as an alternative to the UART interface. The specified DTM operation is invoked and DTM events are returned in the format of a `CommandResponseEvent`.

See the operating mode during which this command can be used in [Table 31. on page 91](#). The command will return a command response event with status `ACI_STATUS_ERROR_DEVICE_STATE_INVALID` when it is used in the incorrect mode.

24.3.2 Message format

Message field/parameter	Value size (bytes)	Data value	Description
Header			
Length	1	3	Packet length
Command	1	0x03	DtmCommand
Content			
DtmCommand	2		Direct Test Mode command (MSB/LSB)

Table 38. ACI message structure for DtmCommand

24.3.3 Accepted values

Parameter	Data value	Description
<i>DtmCommand</i>	Refer to <i>Bluetooth</i> Specification, v. 4.0, Volume 6, Part F, Direct Test Mode, Sect.3.3.2 for a comprehensive list of valid DTM commands.	2 byte DTM command (MSB/LSB) specifying the radio test operation. For transmitter tests, the vendor specific payload (PKT = 11) is implemented as a continuous unmodulated carrier signal at the specified frequency

Table 39. Accepted values for parameters, DtmCommand

24.3.4 Returned events

This command returns a `CommandResponseEvent`.

Data returned in the `CommandResponseEvent` are:

- Command code: `DtmCommand`
- Status:
 - Success / Status code
- Response data (provided Status = Success):
 - DTM Event (2 bytes, MSB/LSB)¹⁵

15. Refer to *Bluetooth* Specification, v. 4.0, Volume 6, Part F, Direct Test Mode, Sect.3.4, 'Events', for description of DTM event format and content

24.3.5 *Bluetooth* low energy procedures used

This command invokes the following *Bluetooth* low energy functionality:

- *Bluetooth* Specification, v. 4.0, Volume 6, Part F, Direct Test

24.4 Sleep (0x04)

Sleep activates the nRF8001 Sleep mode.

24.4.1 Functional description

When in Sleep mode, all active connections are disconnected and no device features are available. Sleep mode should be used whenever possible in order to preserve battery power.

nRF8001 will remain in Sleep mode until receiving the `WakeUp` command.

See the operating mode during which this command can be used in [Table 31. on page 91](#). The command will return a command response event with status `ACI_STATUS_ERROR_DEVICE_STATE_INVALID` when it is used in the incorrect mode.

24.4.2 Message format

Message field/parameter	Value size (bytes)	Data value	Description
Header			
Length	1	1	Packet length
Command	1	0x04	Sleep

Table 40. ACI message structure for Sleep

24.4.3 Accepted values

None

24.4.4 Returned events

None

24.4.5 Bluetooth low energy procedures used

None

24.5 Wakeup (0x05)

Wakeup wakes up nRF8001 from Sleep mode.

24.5.1 Functional description

Upon receiving the `Wakeup` command, nRF8001 is set to Standby mode.

See the operating mode during which this command can be used in [Table 31. on page 91](#). The command will return a command response event with status `ACI_STATUS_ERROR_DEVICE_STATE_INVALID` when it is used in the incorrect mode.

24.5.2 Message format

Message field/parameter	Value size (bytes)	Data value	Description
Header			
Length	1	1	Packet length
Command	1	0x05	Wakeup

Table 41. ACI message structure for Wakeup

24.5.3 Accepted values

None

24.5.4 Returned events

This command returns a `DeviceStartedEvent`. It is then followed by a `CommandResponseEvent`.

Data returned in the `DeviceStartedEvent` is:

- Operating mode: Standby

Data returned in the `CommandResponseEvent` is:

- Command code: `Wakeup`
- Status: Success
- Response data: None

24.5.5 Bluetooth low energy procedures used

None

24.6 Setup (0x06)

Setup uploads the configuration bit pattern generated by nRFGo Studio.

24.6.1 Functional description

Setup is performed by issuing a consecutive series of `Setup` commands. The number and contents of the `Setup` commands required are defined by the nRFGo Studio output.

See the operating mode during which this command can be used in [Table 31. on page 91](#). The command will return a command response event with status `ACI_STATUS_ERROR_DEVICE_STATE_INVALID` when it is used in the incorrect mode.

24.6.2 Message format

Message field/ parameter	Value size (bytes)	Data value	Description
Header			
Length	1	1..31	
Command	1	0x06	Setup
Content			
SetupData	1..30		nRF8001 configuration data exported from nRFGo Studio

Table 42. ACI message structure for Setup

24.6.3 Accepted values

The `Setup` command accepts a configuration bit pattern generated by nRFGo Studio.

24.6.4 Returned events

This command returns a `CommandResponseEvent` followed by a `DeviceStartedEvent` upon completion of the complete `Setup` sequence. Data returned in the `CommandResponseEvent` is:

- Command code: `Setup`
- Status:
 - Status code
 - Transaction continue
 - Transaction complete
 - (Error)
- Response data: None

After the final `Setup` command has been received, nRF8001 will switch to Standby state and execute the new device settings. Upon switching to Standby state, a `DeviceStartedEvent` is generated.

24.6.5 Bluetooth low energy procedures used

None

24.7 ReadDynamicData (0x07)

ReadDynamicData extracts nRF8001 dynamic data for storage in the application controller.

24.7.1 Functional description

This command reads the dynamic data from the nRF8001 volatile memory. The retrieved data can be stored in the application controller while power is disconnected from the nRF8001. The dynamic data is read out as a consecutive series of read dynamic data packets. The read cycle is repeated until all dynamic data has been retrieved.

When power is re-applied to nRF8001, the dynamic data can be reinstated by using the WriteDynamicData command. Once the dynamic data has been reinstated, the device status is restored to the same status valid at the time of performing the ReadDynamicData commands.

See the operating mode during which this command can be used in [Table 31. on page 91](#). The command will return a command response event with status ACI_STATUS_ERROR_DEVICE_STATE_INVALID when it is used in the incorrect mode.

24.7.2 Message format

Message field/parameter	Value size (bytes)	Data value	Description
Header			
Length	1	1	Packet length
Command	1	0x07	ReadDynamicData

Table 43. ACI message structure for ReadDynamicData

24.7.3 Accepted values

None

24.7.4 Returned events

This command returns a `CommandResponseEvent`.

Data returned in the `CommandResponseEvent` is:

- Command code: `ReadDynamicData`
- Status:
 - Continue transaction / Transaction complete / Failure (See [section 28.1 on page 157](#) for details)
- Response data:
 - Sequence number (1 byte): Sequence number of the dynamic data packet. Dynamic data must be restored in the order set by the sequence number.
 - Dynamic data (1..27 bytes): Dynamic data

24.7.5 Bluetooth low energy procedures used

None

24.8 WriteDynamicData (0x08)

WriteDynamicData restores dynamic data to nRF8001 volatile memory.

24.8.1 Functional description

This command writes previously saved dynamic data back to the nRF8001 volatile memory. The dynamic data is written in a consecutive series of WriteDynamicData commands. The write cycle must be repeated until all dynamic data has been written to the nRF8001 volatile memory.

Once the dynamic data has been reinstated, the device status is restored to the same status valid at the time of performing the ReadDynamicData commands. For the device to be functional after restoring dynamic data, device setup¹⁶ must have been performed before restoring unless static data is stored in non-volatile memory¹⁷.

See the operating mode during which this command can be used in [Table 31. on page 91](#). The command will return a command response event with status ACI_STATUS_ERROR_DEVICE_STATE_INVALID when it is used in the incorrect mode.

24.8.2 Message format

Message field/parameter	Value size (bytes)	Data value	Description
Header			
Length	1	2..30	Packet length
Command	1	0x08	WriteDynamicData
Content			
SequenceNumber	1		Data packet sequence number. Data must be written in the same sequence as they were read using the ReadDynamicData command
SetupData	1..27		1..27 bytes of dynamic data extracted using the ReadDynamicData command

Table 44.ACI message structure for WriteDynamicData

24.8.3 Accepted values

None

24.8.4 Returned events

This command returns a CommandResponseEvent.

Data returned in the CommandResponseEvent is:

- Command code: WriteDynamicData
- Status:
 - Transaction continue
 - Transaction complete
 - (Error; see [section 28.1 on page 157](#) for details)
- Response data: None

16. Refer to [section 22.3 on page 80](#)

17. Refer to nRFGo Studio; Setup-lock enabled

24.8.5 *Bluetooth low energy procedures used*

None

24.9 GetDeviceVersion (0x09)

GetDeviceVersion requests nRF8001 version information.

24.9.1 Functional description

This command returns the nRF8001 version and configuration information. The information returned in the `CommandResponseEvent` may be requested by Nordic Semiconductor technical support when this is required.

See the operating mode during which this command can be used in [Table 31. on page 91](#). The command will return a command response event with status `ACI_STATUS_ERROR_DEVICE_STATE_INVALID` when it is used in the incorrect mode.

24.9.2 Message format

Message field/parameter	Value size (bytes)	Data value	Description
Header			
Length	1	1	Packet length
Command	1	0x09	GetDeviceVersion

Table 45. ACI message structure for GetDeviceVersion

24.9.3 Accepted values

None

24.9.4 Returned events

This command returns a `CommandResponseEvent`. Data returned in the event is:

- Command code: `GetDeviceVersion`
- Status: Success
- Response data:
 - Configuration ID (2 bytes); nRF8001 configuration identifier (LSB/MSB). This number can be used to trace the nRF8001 HW and FW versions.
 - ACI protocol version (1 byte); nRF8001 ACI version¹⁸
 - Current setup format (1 bytes); Format identifier of the nRF8001 configuration setup data
 - Setup ID¹⁹ (4 bytes); Setup ID for the application configuration
 - Configuration status (1 byte); bit 0: 1=Setup locked (NVM); 0=Setup open (VM)

24.9.5 Bluetooth low energy procedures used

None

18. The ACI protocol version is mapped to a specific and documented set of ACI commands, ACI events and ACI error and status codes. The version is incremented in the event of additional commands, events and codes being added to the nRF8001 design. The ACI version is backwards compatible with earlier versions.

19. You can set the Setup ID upon creating a configuration setup in nRFgo Studio. The Setup ID can then be used to identify a specific configuration setup and provide traceability for your design.

24.10 GetDeviceAddress (0x0A)

GetDeviceAddress returns the address of the nRF8001 device.

See the operating mode during which this command can be used in [Table 31. on page 91](#). The command will return a command response event with status `ACI_STATUS_ERROR_DEVICE_STATE_INVALID` when it is used in the incorrect mode.

24.10.1 Message format

Message field/parameter	Value size (bytes)	Data value	Description
Header			
Length	1	1	Packet length
Command	1	0x0A	GetDeviceAddress

Table 46. ACI message structure for GetDeviceAddress

24.10.2 Accepted values

None

24.10.3 Returned events

This command returns a `CommandResponseEvent`. Data returned in the event is:

- Command code: `GetDeviceAddress`
- Status: Success / status code
- Response data:
 - Device address (6 byte) : Device address (Byte order LSB to MSB)
 - Address type (1 byte) :
 - 0x01 : Public address
 - 0x02 : Random static address
 - 0x03 : Random Private - Resolvable
 - 0x04 : Random Private - Unresolvable

24.10.4 *Bluetooth* low energy procedures used

None

24.11 GetBatteryLevel (0x0B)

GetBatteryLevel measures the battery supply voltage level.

24.11.1 Functional description

Upon receiving the `GetBatteryLevel` command, the supply voltage level is sampled and reported as a 2 byte number.

See the operating mode during which this command can be used in [Table 31. on page 91](#). The command will return a command response event with status `ACI_STATUS_ERROR_DEVICE_STATE_INVALID` when it is used in the incorrect mode.

24.11.2 Message format

Message field/parameter	Value size (bytes)	Data value	Description
Header			
Length	1	1	Packet length
Command	1	0x0B	<code>GetBatteryLevel</code>

Table 47. ACI message structure for `GetBatteryLevel`

24.11.3 Accepted values

None

24.11.4 Returned events

This command returns a `CommandResponseEvent`.

Data returned in the `CommandResponseEvent` is:

- Command code: `GetBatteryLevel`
- Status: Success
- Response data: Supply voltage level (2 bytes, LSB/MSB). Analog voltage is calculated by multiplying the binary number by 3.52mV .

24.11.5 Bluetooth low energy procedures used

None

24.12 GetTemperature (0x0C)

GetTemperature (0x13) measures the ambient temperature.

24.12.1 Functional description

Upon receiving the `GetTemperature` command, the temperature is measured and reported as a 2 byte number.

See the operating mode during which this command can be used in [Table 31. on page 91](#). The command will return a command response event with status `ACI_STATUS_ERROR_DEVICE_STATE_INVALID` when it is used in the incorrect mode.

24.12.2 Message format

Message field/parameter	Value size (bytes)	Data value	Description
Header			
Length	1	1	Packet length
Command	1	0x0C	<code>GetTemperature</code>

Table 48. ACI message structure for `GetTemperature`

24.12.3 Accepted values

None

24.12.4 Returned events

This command returns a `CommandResponseEvent`.

Data returned in the `CommandResponseEvent` is:

- Command code: `GetTemperature`
- Status: Success
- Response data: Temperature level (2 bytes, 2's complement format, LSB/MSB). Ambient temperature in degrees Celcius is calculated by dividing the binary number by 4. For example, the value 0x000A represents 2.5 °C.

24.12.5 Bluetooth low energy procedures used

None

24.13 RadioReset (0x0E)

RadioReset resets the radio transceiver and forcibly terminates any active connection or advertisement.

24.13.1 Functional description

This command resets the radio transceiver and returns nRF8001 to Standby mode. All dynamic data is retained in memory after execution of the `RadioReset` command. Executing `RadioReset` while in a connection forcibly terminates the connection and returns nRF8001 to Standby mode without generating a `DisconnectedEvent`.

See the operating mode during which this command can be used in [Table 31. on page 91](#). The command will return a command response event with status `ACI_STATUS_ERROR_DEVICE_STATE_INVALID` when it is used in the incorrect mode.

24.13.2 Message format

Message field/parameter	Value size (bytes)	Data value	Description
Header			
Length	1	5	Packet length
Command	1	0x0E	RadioReset

Table 49. ACI message structure for RadioReset

24.13.3 Accepted values

None

24.13.4 Returned events

This command returns a `CommandResponseEvent`.

Data returned in the `CommandResponseEvent` is:

- Command code: `RadioReset`
- Status: Success / Status code
- Response data: None

24.13.5 Bluetooth low energy procedures used

None

24.14 Connect (0x0F)

Connect starts advertising and establishes a connection with a peer device

24.14.1 Functional description

nRF8001 configuration must be completed before issuing this command.

See the operating mode during which this command can be used in [Table 31. on page 91](#). The command will return a command response event with status `ACI_STATUS_ERROR_DEVICE_STATE_INVALID` when it is used in the incorrect mode.

24.14.2 Message format

Message field/parameter	Value size (bytes)	Data value	Description
Header			
Length	1	5	Packet length
Command	1	0x0F	Connect
Content			
Timeout	2		Advertisement time duration in seconds. Upon timeout, nRF8001 stops advertising and exits to Standby mode.
AdvInterval	2		Advertisement interval setting

Table 50. ACI message structure for Connect

24.14.3 Accepted values

Parameter	Data value	Description
<i>Timeout</i>	0x0000	Infinite advertisement, no timeout If required, the <code>RadioReset</code> command will abort the continuous advertisement and return nRF8001 to Standby mode
	1-16383 (0x3FFF)	Valid timeout range in seconds
<i>AdvInterval</i>	32 - 16384 (0x0020 to 0x4000)	Advertising interval set in periods of 0.625 msec

Table 51. Accepted values for parameters, Connect

24.14.4 Returned events

This command returns a series of events in a specific order. The order depends on the outcome of the connection establishment procedure.

In the case of a successful connection establishment, the event order is:

1. `CommandResponseEvent`
2. `ConnectedEvent`
3. `PipeStatusEvent(s)`²⁰

In the case of a failed connection establishment, the event order is:

²⁰. Multiple `PipeStatusEvents` may result depending on the pipe characteristics and the service discovery activity initiated by the peer device.

1. `CommandResponseEvent`
2. `DisconnectedEvent`

Data returned in the `CommandResponseEvent` is:

- Command code: `Connect`
- Status: `Success` / Status code
- Response data: `None`

24.14.5 Bluetooth low energy procedures used

This command starts the following GAP procedures:

- General Discoverable Mode²¹
- Non-Discoverable Mode²²
- Undirected Connectable Mode²³
- Non-Bondable Mode²⁴

21. *Bluetooth* specification, Ver. 4, Vol. 3, Part C (GAP), Sect. 9.2.4

22. *Bluetooth* specification, Ver. 4, Vol. 3, Part C (GAP), Sect. 9.2.2

23. *Bluetooth* specification, Ver. 4, Vol. 3, Part C (GAP), Sect. 9.3.4

24. *Bluetooth* specification, Ver. 4, Vol. 3, Part C (GAP), Sect. 9.4.2

24.15 Bond (0x10)

Bond starts advertising with the intent of setting up a trusted relationship with a peer device

24.15.1 Functional description

nRF8001 configuration must be completed before this command is issued.

See the operating mode during which this command can be used in [Table 31. on page 91](#). The command will return a command response event with status `ACI_STATUS_ERROR_DEVICE_STATE_INVALID` when it is used in the incorrect mode.

24.15.2 Message format

Message field/parameter	Value size (bytes)	Data value	Description
Header			
Length	1	5	Packet length
Command	1	0x10	Bond
Content			
Timeout	2		Advertisement time duration. Upon timeout, nRF8001 stops advertising and exits to Standby mode.
AdvInterval	2		Advertisement interval setting

Table 52. ACI message structure for Bond

24.15.3 Accepted values

Parameter	Data value	Description
<i>Timeout</i>	1-180 (0x0001 – 0x00B4)	Valid advertisement timeout range in seconds
<i>AdvInterval</i>	0x0020 to 0x4000	Advertising interval set in periods of 0.625 msec (LSB/MSB)

Table 53. Accepted values for parameters, Bond

24.15.4 Returned events

This command returns a series of events in a specific order. The order depends on the outcome of the connection establishment and bonding procedure.

In the case of a successful bonding, the event order is:

- `CommandResponseEvent`
- `ConnectedEvent`
- `BondStatusEvent`

In the case of a failed connection establishment or bonding procedure, the event order is:

- `CommandResponseEvent`
- `ConnectedEvent` (Optional)
- `DisconnectedEvent`

Data returned in the `CommandResponseEvent` is:

- Command code: Bond
- Status: Success / Error code
- Response data: None

24.15.5 Bluetooth low energy procedures used

This command starts the following GAP procedures:

- Limited Discoverable Mode²⁵
- Bondable Mode²⁶

25. *Bluetooth* specification, Ver. 4, Vol. 3, Part C (GAP), Sect. 9.2.3

26. *Bluetooth* specification, Ver. 4, Vol. 3, Part C (GAP), Sect. 9.4.3

24.16 Disconnect (0x11)

Disconnect terminates the connection with the peer device.

See the operating mode during which this command can be used in [Table 31. on page 91](#). The command will return a command response event with status `ACI_STATUS_ERROR_DEVICE_STATE_INVALID` when it is used in the incorrect mode.

24.16.1 Message format

Message field/parameter	Value size (bytes)	Data value	Description
Header			
Length	1	2	Packet length
Command	1	0x11	Disconnect
Content			
Reason	1		Reason for connection termination request

Table 54. ACI message structure for Disconnect

24.16.2 Accepted values

Parameter	Data value	Description
<i>Reason</i>	0x01	Request termination of the connection with the peer device with the reason "Remote user terminated connection"
	0x02	Request termination of the link with the peer device with the reason "Unacceptable connection timing"

Table 55. Accepted values for parameters, Disconnect

24.16.3 Returned events

This command returns a `CommandResponseEvent`. It is then followed by a `DisconnectedEvent`.

Data returned in the `CommandResponseEvent` is:

- Command code: `Disconnect`
- Status: Success / Error code
- Response data: None

24.16.4 Bluetooth low energy procedures used

This command starts the following GAP procedures:

- Terminate Connection procedure²⁷

²⁷. Bluetooth specification, Ver. 4, Vol. 3, Part C (GAP), Sect. 9.3.10

24.17 SetTxPower (0x12)

SetTxPower sets the output power level of the *Bluetooth* low energy radio.

See the operating mode during which this command can be used in [Table 31. on page 91](#). The command will return a command response event with status `ACI_STATUS_ERROR_DEVICE_STATE_INVALID` when it is used in the incorrect mode.

24.17.1 Functional description

This command is used to change the radio transmitter output power setting in runtime operation and overwrites the the transmit power setting set in the configuration settings. The transmit power setting set by the `SetTxPower` command will be used for all radio transmissions until set to a different value. In the event of device reset or power cycling, nRF8001 will reset the transmit power to the original configuration data setting. The `ReadDynamicData` command will extract the the transmit power setting set by the `SetTxPower` command as part of the dynamic data.

24.17.2 Message format

Message field/parameter	Value size (bytes)	Data value	Description
Header			
Length	1	2	Packet length
Command	1	0x12	<code>SetTxPower</code>
Content			
RadioTransmitPowerLevel	1		Device output power setting. Radio output power is set to the default value if <code>SetTxPower</code> command is not issued.

Table 56. ACI message structure for `SetTxPower`

24.17.3 Accepted values

Parameter	Data value	Description
<code>RadioTransmitPowerLevel</code>	0x00	-18 dBm
	0x01	-12dBm
	0x02	-6 dBm
	0x03	0 dBm (Default value)

Table 57. Accepted values for parameters, `SetTxPower`

24.17.4 Returned events

This command returns a `CommandResponseEvent`. Data returned in the event is:

- Command code: `SetTxPower`
- Status: Success / Error code
- Response data: None

24.17.5 *Bluetooth* low energy procedures used

None

24.18 ChangeTimingRequest (0x13)

ChangeTimingRequest initiates the connection parameter update procedure.

24.18.1 Functional description

This command is used to request the peer device to change the connection timing. The command can be given both with or without the timing parameters specified.

If the command is given without any timing parameters included, the timing request will use the timing values specified in nRFgo Studio as part of the device configuration setup. If the command is sent with timing parameters included, the timing request will use the timing parameters specified in the `ChangeTimingRequest` command when it sends the request to the peer device. All 4 timing parameters must be specified in the command. That is, the length field can only be 1 or 9.

See the operating mode during which this command can be used in [Table 31. on page 91](#). The command will return a command response event with status `ACI_STATUS_ERROR_DEVICE_STATE_INVALID` when it is used in the incorrect mode.

24.18.2 Message format

Message field/parameter	Value size (bytes)	Data value	Description
Header			
Length	1	1 or 9	
Command	1	0x13	ChangeTimingRequest
Content			
<i>Interval Min</i>	2	Interval Min	Minimum value for the connection event interval (LSB/MSB)
<i>Interval Max</i>	2	Interval Max	Maximum value for the connection event interval (LSB/MSB)
<i>Slave latency</i>	2	Slave latency	Slave latency setting (LSB/MSB)
<i>Timeout</i>	2	Timeout	Timeout value for the connection (LSB/MSB)

Table 58. ACI message structure for ChangeTimingRequest

24.18.3 Accepted values

Parameter	Data value	Description
<i>Interval Min</i>	6..3200	Minimum interval = data value multiplied by 1,25ms
<i>Interval Max</i>	6..3200	Maximum interval = data value multiplied by 1,25ms
<i>Slave latency</i>	0..1000 (0x0000 - 0x03E8)	The number of consecutive connection events that the slave is not required to respond
<i>Timeout</i>	10..3200	Timeout = data value multiplied by 10ms

Table 59. Accepted values for parameters, ChangeTimingRequest

24.18.4 Returned events

Events are returned in the following order:

1. Command response event.
2. Timing event.

The application controller should examine the Timing Event against the requested timing to verify that the link timing was changed successfully.

Data returned in the `CommandResponseEvent` is:

- Command code: `ChangeTimingRequest`
- Status: Success / Status code
- Response data: None

Figure 51. illustrates the communication scenarios for the `ChangeTimeRequest` command.

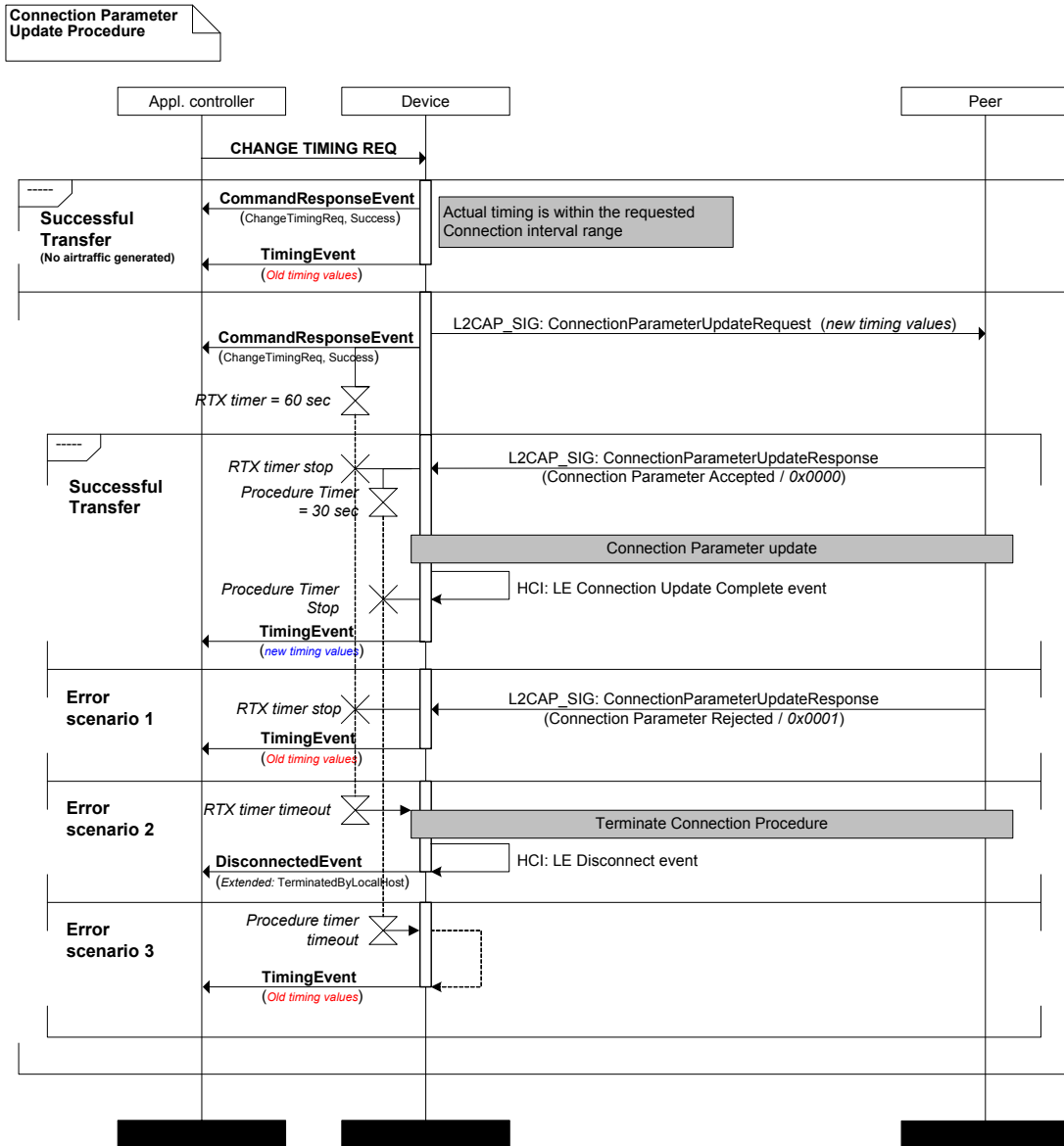

Figure 51. `ChangeTimingRequest` MSC

24.18.5 Bluetooth low energy procedures used

The following GAP procedures are used to change connection timing:

- Connection Parameter Update Procedure²⁸

²⁸ Bluetooth specification Ver 4.0, Vol. 3, Part C (GAP), Sect. 9.3.9

24.19 OpenRemotePipe (0x14)

OpenRemotePipe opens a remote receive pipe from a peer device for data transfer.

24.19.1 Functional description

This command is used to open service pipes.

The Receive (Remote) pipe and the Receive with acknowledgment (Remote) pipe types are closed by default. Data cannot be received from the peer device on these service pipes unless the pipes are opened using the `OpenRemotePipe` command.

This command can be used only after the service discovery procedure has successfully completed and resulted in a `ConnectedEvent` and `PipeStatusEvent`(s). The `PipeStatusEvent` will return a bitmap identifying the service pipes that needs opening before data transfer can take place. Only service pipes identified in the `PipesClosed` can be opened using this command.

See the operating mode during which this command can be used in [Table 31. on page 91](#). The command will return a command response event with status `ACI_STATUS_ERROR_DEVICE_STATE_INVALID` when it is used in the incorrect mode.

24.19.2 Message format

Message field/parameter	Value size (bytes)	Data value	Description
Header			
Length	1	2	Packet length
Command	1	0x14	<code>OpenRemotePipe</code>
Content			
ServicePipeNumber	1		ID of the service pipe to open.

Table 60. ACI message structure for `OpenRemotePipe`

24.19.3 Accepted values

Parameter	Data value	Description
<code>ServicePipeNumber</code>	1..62	Must be one of the service pipes listed in the <code>ClosedPipes</code> bitmap returned in the <code>PipeStatusEvent</code>

Table 61. Accepted values for parameters, `OpenRemotePipe`

24.19.4 Returned events

This command returns a `CommandResponseEvent`. It is then followed by a `PipeStatusEvent` reporting the result of the procedure and an updated pipe bitmap identifying the service pipes available for data transfer.

In case of a failed procedure execution, a `PipeErrorEvent` is returned instead of the `PipeStatusEvent`.

Data returned in the `CommandResponseEvent` is:

- Command code: `OpenRemotePipe`

-
- Status: Success / Status code
 - Response data:

See [Figure 33. on page 68](#) for an MSC illustrating the use of the `OpenRemotePipe` command.

24.19.5 Bluetooth low energy procedures used

This command uses the following GATT procedures²⁹:

- Write Characteristic Value (CCCD configuration)
- Characteristic Value Notification (pipe without acknowledgment feature)
- Characteristic Value Indication (pipe with acknowledgment feature)

²⁹. *Bluetooth* specification Ver 4.0, Vol. 3, Part G, Chapter 4.2

24.20 SetApplLatency (0x19)

SetApplLatency sets the application latency. It is only usable if the connection is using slave latency.

24.20.1 Functional Description

SetApplLatency subrates the slave latency. nRF8001 will listen on each subrated interval and only acknowledge the received packet from the central device if it has its MD (More Data) bit set to 1 or contains data.

See the operating mode during which this command can be used in [Table 31. on page 91](#). The command will return a command response event with status `ACI_STATUS_ERROR_DEVICE_STATE_INVALID` when it is used in the incorrect mode.

24.20.2 Message Format

Message field/ parameter	Value size (bytes)	Data value	Description
Header			
Length	1	4	Packet Length
Command	1	0x19	SetApplLatency
Content			
<i>ApplLatencyMode</i>	1		Enable/ Disables the application latency feature
<i>Latency</i>	2		Number of consecutive connection events that nRF8001 does not listen for the master.

Table 62. ACI message structure for SetApplLatency

24.20.3 Accepted values

Parameter	Data value	Description
<i>ApplLatencyMode</i>	0x00	Application Latency Disabled (Default value on connection)
	0x01	Application Latency Enabled
<i>Latency</i>	0 .. (<i>Slave Latency</i> -1)	The number of consecutive connection events that nRF8001 does not listen for the master. This value must be seen in conjunction with the <i>Slave latency</i> . Application Latency is disabled if it is set to a number higher or equal to the <i>Slave latency</i> number (see also Table 58. on page 116).

Table 63. Accepted values for parameters, *ApplLatencyMode*

24.20.4 Returned events

This command returns a `CommandResponseEvent`. Data returned in the event is:

- Command code: `SetApplLatency`

- Status: Success / Error code
- Response data: None

24.20.5 Bluetooth low energy procedures used

This command uses subsections of the controller specification as defined in:

- *Bluetooth* Specification, v. 4.0, Volume 6, Part B Section 4.5.1 Connection events
- *Bluetooth* Specification, v. 4.0, Volume 6, Part B Section 4.5.6 Closing connection events

24.21 SetKey (0x1A)

SetKey sets the passkey that is used in the pairing procedure. This command should be sent after a Key Request event has been received.

24.21.1 Functional Description

SetKey command is used only if the security I/O settings (see [section 22.4.5 on page 85](#)) are set to indicate to the peer device that MITM security is required. If MITM is not required then I/O settings should be set so that the security level is Just Works security.

See the operating mode during which this command can be used in [Table 31. on page 91](#). The command will return a command response event with status `ACI_STATUS_ERROR_DEVICE_STATE_INVALID` when it is used in the incorrect mode.

24.21.2 Message Format

Message field/ parameter	Value size (bytes)	Data value	Description
Header			
Length	1	2, 8, or 18	Packet Length
Command	1	0x1A	SetKey
Content			
KeyType	1		Which key to set
Key	0 or 6		The key to be used in the on-going pairing process

Table 64. ACI message structure for SetKey

24.21.3 Accepted values

Parameter	Data value	Description
KeyType	0x00	Invalid key: Reject key request
	0x01	Passkey, 6 byte
Key		If KeyType == 0x00 N/A (field not present)
		If KeyType == 0x01 Fixed 6 byte ASCII string representing the passkey (no NULL termination, '0'-'9' digits only) Examples: "000123", "999999"

Table 65. Accepted values for parameters, SetKey

24.21.4 Returned events

This command returns a `CommandResponseEvent`. Data returned in the event is:

- Command code: `SetKey`
 - Status: Success / Error code
- Response data: None

24.21.5 Bluetooth low energy procedures used

This command uses the following GAP procedures:

- *Bluetooth* Specification, v. 4.0, Vol 3, Part C, Chapter 10

24.22 OpenAdvPipe (0x1B)

OpenAdvPipe sets the pipes that are used for advertising data.

24.22.1 Functional Description

OpenAdvPipe command configures the advertisements pipes that broadcast data. The pipes start advertising data when enabled either through the Bond command (see [section 24.15 on page 112](#)), Connect command (see [section 24.18 on page 116](#)) or, the Broadcast command (see [section 24.23 on page 127](#)). The data that is sent in the advertisement packets is set by using the SetLocalData command, (see [section 25.1 on page 132](#)). Multiple pipes may be enabled simultaneously. Device configuration must be completed before sending this command.

See [chapter 26.8 on page 147](#) for an example of a pipe bitmap.

See the operating mode during which this command can be used in [Table 31. on page 91](#). The command will return a command response event with status `ACI_STATUS_ERROR_DEVICE_STATE_INVALID` when it is used in the incorrect mode.

24.22.2 Message Format

Message field/ parameter	Value size (bytes)	Data value	Description
Header			
Length	1	9	Packet Length
Command	1	0x1B	OpenAdvPipe
Content			
AdvServiceDataPipes	8		Bitmap of pipes to be placed in advertisement Service Data fields

Table 66. ACI message structure for OpenAdvPipe

24.22.3 Accepted values

Parameter	Data value	Description
AdvServiceDataPipes	0000000000000000 - FFFFFFFFFFFFFF7F	Pipe bitmap where '1' indicates that the corresponding Broadcast pipe data is to be placed in AD Service Data fields. See section 26.8.1 on page 147 for the pipe bitmap.

Table 67. Accepted values for parameters, AdvServiceDataPipes

24.22.4 Returned events

This command returns a `CommandResponseEvent`. Data returned in the event is:

- Command code: OpenAdvPipe
- Status: Success / Error code
- Response data: None

24.22.5 Bluetooth low energy procedures used

None

24.23 Broadcast (0x1C)

Broadcast enables a pipe to start sending advertisement data on non-connectable advertisement packets.

24.23.1 Functional Description

Broadcast command starts nRF8001 advertising using non-connectable advertisement packets. The type of advertisement packet used is defined in the device configuration by using the nRFGo Studio setup tool. Any broadcast pipe that is enabled will have its local data sent in the advertisement packet.

See the operating mode during which this command can be used in [Table 31. on page 91](#). The command will return a command response event with status `ACI_STATUS_ERROR_DEVICE_STATE_INVALID` when it is used in the incorrect mode.

24.23.2 Message Format

Message field/ parameter	Value size (bytes)	Data value	Description
Header			
Length	1	5	
Command	1	0x1C	Broadcast
Content			
<i>Timeout</i>	2		Time, in seconds, to advertise before exiting to Standby mode
<i>AdvInterval</i>	2		Advertising interval timing to be used

Table 68. ACI message structure for Broadcast

24.23.3 Accepted values

Parameter	Data value	Description
<i>Timeout</i>	0x0000	Infinite; continuous advertising.
	0x0001 ... 0x3FFF	Valid timeout range in second (1..16383)
<i>AdvInterval</i>	0x0020 ... 0x4000	Advertising interval set in periods of 0.625 msec. Valid range from 0x0020 to 0x4000

Table 69. Accepted values for parameters, Broadcast

24.23.4 Returned events

This command returns a `CommandResponseEvent`. Data returned in the event is:

- Command code: `Broadcast`
- Status: Success / Error code
- Response data: None

24.23.5 Bluetooth low energy procedures used

This command uses the following GAP procedures

- *Bluetooth* Specification, v. 4.0, Vol 3, Part C, Chapter 9.1

24.24 BondSecurityRequest (0x1D)

BondSecurityRequest command sends the Security Manager Protocol (SMP) Security Request Command.

24.24.1 Functional Description

BondSecurityRequest command allows the application controller to initiate and send the SMP Security Request Command as described in the Bluetooth Security Manager protocol.

The request can be initiated by the application controller under the following conditions:

- nRF8001 is in Bond mode (see [section 24.15 on page 112](#))
- After a connection has been established
- A security procedure has not been initiated by the peer device

If a security procedure has already been initiated by the peer device then the BondSecurityRequest command is flushed from nRF8001.

See the operating mode during which this command can be used in [Table 31. on page 91](#). The command will return a command response event with status `ACI_STATUS_ERROR_DEVICE_STATE_INVALID` when it is used in the incorrect mode.

24.24.2 Message Format

Message field/ parameter	Value size (bytes)	Data value	Description
Header			
Length	1	1	
Command	1	0x1D	BondSecRequest
Content			

Table 70. ACI message structure for BondSecurityRequest

24.24.3 Accepted values

None

24.24.4 Returned events

This command returns a `CommandResponseEvent`. Data returned in the event is:

- Command code: `BondSecRequest`
- Status: Success / Error code
- Response data: None

24.24.5 Bluetooth low energy procedures used

This command initiates the following SM procedure:

- *Bluetooth* Specification, v. 4.0, Vol 3, Part H, Chapter 2.4.6

24.25 DirectedConnect (0x1E)

DirectedConnect command initiates Directed Advertisement (see Bluetooth Specification, Ver. 4.0, Vol 6, section 4.4.2.4) in nRF8001.

24.25.1 Functional Description

DirectedConnect commands can be used only when bonded with the peer device. nRF8001 will advertise using directed advertisement packets for a fixed period of 1.28 seconds. Device configuration must be completed before running the Directed Connect command.

See the operating mode during which this command can be used in [Table 31. on page 91](#). The command will return a command response event with status `ACI_STATUS_ERROR_DEVICE_STATE_INVALID` when it is used in the incorrect mode.

24.25.2 Message Format

Message field/ parameter	Value size (bytes)	Data value	Description
Header			
Length	1	1	
Command	1	0x1E	DirectedConnect
Content			

Table 71. ACI message structure for DirectedConnect

24.25.3 Accepted values

None

24.25.4 Returned events

This command returns a `CommandResponseEvent`. Data returned in the event is:

- Command code: `DirectedConnect`
- Status: Success / Error code
- Response data: None

24.25.5 Bluetooth low energy procedures used

This command uses the following GAP procedure:

- *Bluetooth* Specification, v. 4.0, Vol 3, Part C, Sect. 9.3.3

24.26 CloseRemotePipe (0x1F)

CloseRemotePipe closes a remote receive pipe (with or without acknowledgement) from a peer device.

24.26.1 Functional description

This command is used to close service pipes which have been opened by the OpenRemotePipe command.

This command can be used only after the OpenRemotePipe command has been successfully completed. Once the pipe has been closed, it will be listed in the PipeClosed bitmap.

See the operating mode during which this command can be used in [Table 31. on page 91](#). The command will return a command response event with status `ACI_STATUS_ERROR_DEVICE_STATE_INVALID` when it is used in the incorrect mode.

24.26.2 Message format

Message field/parameter	Value size (bytes)	Data value	Description
Header			
Length	1	2	Packet length
Command	1	0x1F	CloseRemotePipe
Content			
ServicePipeNumber	1		ID of the service pipe to close.

Table 72. ACI message structure for CloseRemotePipe

24.26.3 Accepted values

Parameter	Data value	Description
<i>ServicePipeNumber</i>	1..62	Must be one of the service pipes listed in the OpenPipes bitmap returned in the PipeStatusEvent

Table 73. Accepted values for parameters, CloseRemotePipe

24.26.4 Returned events

This command returns a `CommandResponseEvent`. It is then followed by a `PipeStatusEvent` reporting the result of the procedure and an updated pipe bitmap identifying the service pipes available for data transfer.

In case of a failed procedure execution, a `PipeErrorEvent` is returned instead of the `PipeStatusEvent`.

Data returned in the `CommandResponseEvent` is:

- Command code: `CloseRemotePipe`
- Status: Success / Status code
- Response data:

See [section 20.5.2 on page 68](#) for an MSC illustrating the use of the `CloseRemotePipe` command.

24.26.5 Bluetooth low energy procedures used

This command uses the following GATT procedures³⁰:

- Write Characteristic Value (CCCD configuration)
- Characteristic Value Notification (pipe without acknowledgment feature)
- Characteristic Value Indication (pipe with acknowledgment feature)

³⁰. *Bluetooth* specification Ver 4.0, Vol. 3, Part G, Chapter 4.2

25 Data commands

Data commands are commands that either aim to transfer, or receive, application data when nRF8001 is in a connected state with a peer device.

25.1 SetLocalData (0x0D)

SetLocalData sets a local Characteristic Value or Characteristic Descriptor.

25.1.1 Functional description

The SetLocalData command is used to set data stored in the local server (Server) through the associated service pipe. For local transmit pipes, this command does not trigger a Handle Value Notification or Handle Value Indication to the peer device.

See the operating mode during which this command can be used in [Table 32. on page 91](#). The command will return a Command Response Event with status ACI_STATUS_ERROR_DEVICE_STATE_INVALID when it is used in the incorrect mode.

25.1.2 Message format

Message field/parameter	Value size (bytes)	Data value	Description
Header			
Length	1	2..22	Packet length
Command	1	0x0D	SetLocalData
Content			
ServicePipeNumber	1		ID of the service transmit pipe through which the data is set
Data	0..20		Application data

Table 74. ACI message structure for SetLocalData

25.1.3 Accepted values

Parameter	Data value	Description
ServicePipeNumber	1..62	One of the available ServicePipeNumbers identified in the PipeStatusEvent
Data		The data payload size must not exceed the maximum length defined in the local server (Server) (Limited to a maximum of 20 bytes in length)

Table 75. Accepted values for parameters, SetLocalData

25.1.4 Returned events

This command returns a `CommandResponseEvent`. Data returned in the event is:

- Command code: `SetLocalData`
- Status: Success / Status code
- Response data: None

25.1.5 *Bluetooth low energy procedures used*

None

25.2 SendData (0x15)

SendData sends data to a peer device through a transmit service pipe.

See the operating mode during which this command can be used in [Table 32. on page 91](#). The command will return a Command Response Event with status ACI_STATUS_ERROR_DEVICE_STATE_INVALID when it is used in the incorrect mode.

25.2.1 Message format

Message field/parameter	Value size (bytes)	Data value	Description
Header			
Length	1	2..22	Packet length
Command	1	0x15	SendData
Content			
ServicePipeNumber	1		ID of the service transmit pipe through which data is sent
Data	1..20		Application data

Table 76. ACI message structure for SendData

25.2.2 Accepted values

Parameter	Data value	Description
ServicePipeNumber	1..62	Must be a pipe listed in the OpenPipes bitmap returned in the PipeStatusEvent
Data	-	The data payload size must not exceed the maximum length defined in nRFgo Studio in the local service configuration (1..20 bytes)

Table 77. Accepted values for parameters, SendData

25.2.3 Returned events

This command returns the DataCreditEvent. When using a transmit pipe with acknowledgment, this command returns a DataAckEvent and a DataCreditEvent. A PipeErrorEvent will occur if the transmission fails.

25.2.4 Bluetooth low energy procedures used

This command uses the following GATT procedures³¹:

- Notifications (TX pipe, Local)
- Indications (TX pipe, Local, Ack)
- Read Characteristic Value / Read Using Characteristic UUID (TX pipe, Local, Ack)
- Write Without Response (Tx pipe, Remote)
- Write Characteristic Value (Tx pipe, Remote, Ack)
- Read Characteristic Value (RX pipe, Remote, Req)

31. Bluetooth specification Ver. 4.0, Vol. 3, Part G, Chapter 4.2

25.3 SendDataAck (0x16)

SendDataAck confirms reception of data from a peer device.

25.3.1 Functional description

This command is used in conjunction with the `DataReceivedEvent`. When data is received on a receive pipe with the acknowledgment feature enabled, the application controller shall respond with a `SendDataAck` command. When nRF8001 receives the `SendDataAck` command, a confirmation is sent to the peer device. This confirmation will be either Handle Value Confirmation if the data is stored locally or Write Response if data is stored remotely. See [section 20.4 on page 60](#) and [section 20.5 on page 66](#) for MSCs illustrating data transfer with acknowledgment.

See the operating mode during which this command can be used in [Table 32. on page 91](#). The command will return a Command Response Event with status `ACI_STATUS_ERROR_DEVICE_STATE_INVALID` when it is used in the incorrect mode.

25.3.2 Message format

Message field/parameter	Value size (bytes)	Data value	Description
Header			
Length	1	2	Packet length
Command	1	0x16	<code>SendDataAck</code>
Content			
ServicePipeNumber	1		Number of the service pipe on which the acknowledge is to be sent

Table 78. ACI message structure for `SendDataAck`

25.3.3 Accepted values

Parameter	Data value	Description
<code>ServicePipeNumber</code>	1..62	Must a pipe listed in the OpenPipes bitmap returned in the <code>PipeStatusEvent</code>

Table 79. Accepted values for parameters, `SendDataAck`

25.3.4 Returned events

None

25.3.5 Bluetooth low energy procedures used

This command uses the following GATT procedures³²:

- Characteristic Value Indication
- Write Response
- Handle Value Confirmation

32. Bluetooth specification Ver. 4.0, Vol. 3, Part G, Chapter 4.2

25.4 RequestData (0x17)

RequestData requests data from a peer device through a service receive pipe.

See the operating mode during which this command can be used in [Table 32. on page 91](#). The command will return a Command Response Event with status `ACI_STATUS_ERROR_DEVICE_STATE_INVALID` when it is used in the incorrect mode.

25.4.1 Message format

Message field/parameter	Value size (bytes)	Data value	Description
Header			
Length	1	2	Packet length
Command	1	0x17	RequestData
Content			
ServicePipeNumber	1		Service Pipe Number of the service receive pipe to request data from

Table 80. ACI message structure for RequestData (0xA4)

25.4.2 Accepted values

Parameter	Data value	Description
ServicePipeNumber	1..62	Must be a pipe listed in the OpenPipes bitmap returned in the PipeStatusEvent

Table 81. Accepted values for parameters, RequestData

25.4.3 Returned events

This command returns `DataReceivedEvent` upon reception of the requested data. Alternatively a `PipeErrorEvent` is returned in case of transmission failure.

25.4.4 Bluetooth low energy procedures used

The following GATT procedures are used to receive data from a remote device³³:

- Read Characteristic Value

33. Bluetooth specification Ver. 4.0, Vol. 3, Part G, Chapter 4.2

25.5 SendDataNack (0x18)

SendDataNack negatively acknowledges (nacks) reception of data from a peer device.

25.5.1 Functional Description

SendDataNack can be used after receiving a DataReceivedEvent. When data is received on a pipe that requires an acknowledgement, the application controller may nack the data. When nRF8001 receives the SendDataNack command it will send an attribute protocol error response to the peer device.

See the operating mode during which this command can be used in [Table 32. on page 91](#). The command will return a Command Response Event with status ACI_STATUS_ERROR_DEVICE_STATE_INVALID when it is used in the incorrect mode.

25.5.2 Message Format

Message field/ parameter	Value size (bytes)	Data value	Description
Header			
Length	1	3	
Command	1	0x18	SendDataNack
Content			
<i>PipeNumber</i>	1		On which pipe the data is negatively acknowledged.
<i>ErrorCode</i>	1		Attribute protocol error code to be sent to the peer device.

Table 82. ACI message for structure for SendDataNack

25.5.3 Accepted values

Parameter	Data value	Description
<i>PipeNumber</i>	1..62	Valid pipe number in the range 1..62
<i>ErrorCode</i>	0x80..0xFF	Error Code

Table 83. Accepted values for parameters, SendDataNack

25.5.4 Returned events

This command returns a DataCreditEvent.

25.5.5 Bluetooth low energy procedures used

- *Bluetooth* Specification, v. 4.0, Vol 3, Part F, Sect. 3.4.1

26 System Events

System events are event packets that have been triggered by a predefined condition and are sent by nRF8001 to the application controller.

26.1 DeviceStartedEvent (0x81)

DeviceStartedEvent indicates reset recovery or a state change.

26.1.1 Functional description

This event is sent from nRF8001 to the external application controller when nRF8001 is reset or changing operating mode.

26.1.2 Message format

Message field/parameter	Value size (bytes)	Data value	Description
Header			
Length	1	4	Packet length
Event	1	0x81	DeviceStartedEvent
Content			
OperatingMode	1		Current device mode
HWEError	1		Cause of the restart
DataCreditAvailable	1		Available buffers

Table 84. ACI message structure for DeviceStartedEvent

26.1.3 Returned values

Parameter	Data value	Description
<i>OperatingMode</i>	0x01	Test
	0x02	Setup
	0x03	Standby
<i>HWEError</i>	0x00	No error
	0x01	Fatal error
<i>DataCreditAvailable</i>	00	Number of DataCommand buffers available

Table 85. Accepted values for parameters, DeviceStartedEvent

26.1.4 Bluetooth low energy procedures used

None

26.2 EchoEvent (0x82)

EchoEvent returns a copy of the Echo ACI message.

26.2.1 Functional description

This event returns an identical copy of the PDU sent using the `Echo` command in Test mode.

26.2.2 Message format

Message field/ parameter	Value size (bytes)	Data value	Description
Header			
Length	1	1..30	Packet length
Event	1	0x82	EchoEvent
Content			
EchoMessage	0..29		Echo data

Table 86. ACI message structure for EchoEvent

26.2.3 Returned values

Parameter	Data value	Description
<i>EchoMessage</i>	-	Message identical to the <i>Data</i> parameter content of the last <code>Echo</code> command

Table 87. Accepted values for parameters, EchoEvent

26.2.4 Bluetooth low energy procedures used

None

26.3 HardwareErrorEvent (0x83)

DebugInfoEvent returns hardware error debug information.

26.3.1 Functional description

This event is sent from nRF8001 to the external application controller to provide debug information. In case of firmware failure this event follows the `DeviceStartedEvent`.

26.3.2 Message format

Message field/ parameter	Value size (bytes)	Data value	Description
Header			
Length	1	25	Packet length
Event	1	0x83	HardwareErrorEvent
Content			
LineNumber	2		Code line where firmware failed
FileName	22		Name of the firmware file where the error occurred.

Table 88. ACI message structure for HardwareError Event

26.3.3 Returned values

Parameter	Data value	Description
LineNumber		Code line where the firmware failed
FileName		Zero-terminated string

Table 89. Accepted values for parameters, HardwareErrorEvent

26.3.4 Bluetooth low energy procedures used

None

26.4 CommandResponseEvent (0x84)

CommandResponseEvent confirms reception or execution of an ACI command.

26.4.1 Functional description

This event is sent from nRF8001 to the external application controller in response to ACI commands.

26.4.2 Message format

Message field/parameter	Value size (bytes)	Data value	Description
Header			
Length	1	3..30	Packet length
Event	1	0x84	CommandResponseEvent
Content			
CommandOpCode	1		OP code of the command to which the event responds
Status	1		Status of the command execution
ResponseData	0..27		Command-specific data

Table 90. ACI message structure for CommandResponseEvent

26.4.3 Returned values

Parameter	Data value	Description
<i>CommandOpCode</i>		Command OP code
<i>Status</i>	0x00	Success
	0x01 - 0xFF	Status code. See section 28.1 on page 157 for a comprehensive list of status codes.
<i>ResponseData</i>		See the specific ACI command description for a list of return parameters associated with the command.

Table 91. Returned values for CommandResponseEvent

26.4.4 Bluetooth low energy procedures used

None

26.5 ConnectedEvent (0x85)

ConnectedEvent indicates that a connection has been established with a peer device

26.5.1 Functional description

This event is sent from nRF8001 to the external application controller upon connection establishment with a peer device.

26.5.2 Message format

Message field/parameter	Value size (bytes)	Data value	Description
Header			
Length	1	15	Packet length
Event	1	0x85	ConnectedEvent
Content			
<i>AddressType</i>	1		Peer Address Type
<i>PeerAddress</i>	6		Peer Device Address
<i>ConnectionInterval</i>	2		Connection Interval setting (LSB/MSB)
<i>SlaveLatency</i>	2		Slave latency setting (LSB/MSB)
<i>SupervisionTimeout</i>	2		Supervision timeout period (LSB/MSB)
<i>MasterClockAccuracy</i>	1		Master (peer device) clock accuracy

Table 92. ACI message structure for ConnectedEvent

26.5.3 Returned values

Parameter	Data value	Description
<i>AddressType</i>	0x01	Public address
	0x02	Random Static Address
	0x03	Random Private Address (Resolvable)
	0x04	Random Private Address (Un-resolvable)
<i>ConnectionInterval</i>	-	Connection interval set in periods of 1.25 ms
<i>SlaveLatency</i>	0..1000 (0x0000 - 0x03E8)	The number of consecutive connection events that the slave is not required to respond
<i>SupervisionTimeout</i>	-	Supervision timeout in seconds when multiplied with 10ms
<i>MasterClockAccuracy</i>	0x00	500 ppm
	0x01	250 ppm
	0x02	150 ppm
	0x03	100 ppm
	0x04	75 ppm
	0x05	50 ppm
	0x06	30 ppm
	0x07	20 ppm

Table 93. Returned values for ConnectedEvent

26.5.4 ***Bluetooth low energy procedures used***

None

26.6 DisconnectedEvent (0x86)

DisconnectedEvent indicates the loss of a connection.

26.6.1 Functional description

This event is sent from nRF8001 to the external application controller to notify the application controller that connection with the peer device has been lost.

26.6.2 Message format

Message field/ parameter	Value size (bytes)	Data value	Description
Header			
Length	1	3	Packet length
Event	1	0x86	DisconnectedEvent
Content			
<i>AciStatus</i>	1		Reason for disconnection (Local Host origin)
<i>BtLeStatus</i>	1		Reason for disconnection, <i>Bluetooth</i> error code (Origin not related to local Host)

Table 94. ACI message structure for DisconnectedEvent

26.6.3 Returned values

Parameter	Data value	Description
<i>AciStatus</i>	0x03	Check the <i>Bluetooth</i> low energy status code; <i>BtLeStatus</i>
	0x93	Timeout while advertising, unable to establish connection
	0x8D	Bond required to proceed with connection
<i>BtLeStatus</i>	0x00	n/a
	0x01..0xFF	See the <i>Bluetooth</i> specification, v. 4.0, Volume 2, Part D, Error Code Description for a complete list of error codes

Table 95. Returned values for DisconnectedEvent

26.6.4 Bluetooth low energy procedures used

None

26.7 BondStatusEvent (0x87)

BondStatusEvent returns the bonding procedure execution status

26.7.1 Functional description

This event is sent from nRF8001 to the application controller upon successful execution of the bonding procedure. In case of a failed bonding procedure, a `DisconnectedEvent` will result instead of a `BondStatusEvent`.

26.7.2 Message format

Message field/parameter	Value size (bytes)	Data value	Description
Header			
Length	1	7	Packet length
Event	1	0x87	<code>BondStatusEvent</code>
Content			
<i>BondStatusCode</i>	1		Bond Status code
<i>BondStatusSource</i>	1		Bond Status source
<i>BondStatus-SecMode1</i>	1		LE security mode 1
<i>BondStatus-SecMode2</i>	1		LE security mode 2
<i>BondStatus-KeyExchSlave</i>	1		Keys exchanged (slave)
<i>BondStatus-KeyExchMaster</i>	1		Keys exchanged (master)

Table 96. ACI message structure for `BondStatusEvent`

26.7.3 Returned values

Parameter	Data value	Description
<i>BondStatusCode</i>	0x00	Bond succeeded
	0x01..0xFF	Bond Failed, see section 28.2 on page 158 for more information
<i>BondStatusSource</i>	0x01	Status code generated locally
	0x02	Status code generated by the remote peer
<i>BondStatus-SecMode1</i>	-	Levels supported in LE Security Mode 1 <ul style="list-style-type: none"> • bit0: level 1 • bit1: level 2 • bit2: level 3 • bit3..7: <i>reserved</i>
<i>BondStatus-SecMode2</i>	-	Levels supported in LE Security Mode 2 <ul style="list-style-type: none"> • bit0: level 1 • bit1: level 2 • bit2..7: <i>reserved</i>
<i>BondStatus-KeyExchSlave</i>	-	Keys exchanged (slave distributed keys) <ul style="list-style-type: none"> • bit0: LTK using Encryption Information command • bit1: EDIV and Rand using Master Identification command • bit2: IRK using Identity Information command • bit3: Public device or static random address using Identity Address Information command • bit4: CSRK using Signing Information command • bit5..7: <i>reserved</i>
<i>BondStatus-KeyExchMaster</i>	-	Keys exchanged (master distributed keys) <ul style="list-style-type: none"> • bit0: LTK using Encryption Information command • bit1: EDIV and Rand using Master Identification command • bit2: IRK using Identity Information command • bit3: Public device or static random address using Identity Address Information command • bit4: CSRK using Signing Information command • bit5..7: <i>reserved</i>

Table 97. Returned values for *BondStatusEvent*

26.7.4 Bluetooth low energy procedures used

None

26.8 PipeStatusEvent (0x88)

PipeStatusEvent lists the pipe connection and availability status

26.8.1 Functional description

This event is sent from nRF8001 to the external application controller whenever there is a change in service pipe availability status.

The `PipeStatusEvent` returns two pipe lists in the form of two 64-bit bitmaps:

- **PipesOpen:** Available service pipes on which data can be received (or transmitted) without further action.
- **PipesClosed:** Service pipes on which data can be received only after nRF8001 has instructed the Client (peer device) to send data. These service pipes are opened using the `OpenRemotePipe` command.

See [section 20.6 on page 72](#) for a functional description on pipe availability.

Each bit in the bitmaps corresponds to a service pipe. For the PipesOpen bitmap, a bit is set to '1' indicates that the service pipe is available, when set to '0' it is unavailable. For the PipesClosed bitmap, a bit is set to '1' indicates that the service pipe requires opening, when set to '0' no action is required.

The service pipes are counted from the first byte starting with the least significant bit.

The following two examples show a bitmap for an open pipe and a closed pipe respectively, see [Table 98. on page 148](#) for an example of a bitmap returned:

- If **PipesOpen bitmap = 0xFEFF0D0000000800** then the nRF8001 service discovery procedure execution has not completed and the following service pipes are open; Pipes 1 through 16, 18, 19 and 51.
- If **PipesClosed bitmap = 0x0000821100100000** then service pipes 17, 23, 24, 28 and 44 require opening.

Table 98. shows an example of a bitmap returned by a `PipeStatusEvent..`

Bitmap bytes	Byte 1								Byte 2							
Service pipe number	7	6	5	4	3	2	1	0	15	14	13	12	11	10	9	8
PipesOpen (bits)	1	1	1	1	1	1	1	0	1	1	1	1	1	1	1	1
PipesOpen (byte values)	0xFE								0xFF							
PipesClosed (bits)	0	0	0	0	0	0	0	0	0	0	0	0	0	0	0	0
PipesClosed (byte values)	0x00								0x00							
Bitmap bytes	Byte 3								Byte 4							
Service pipe number	23	22	21	20	19	18	17	16	31	30	29	28	27	26	25	24
PipesOpen (bits)	0	0	0	0	1	1	0	1	0	0	0	0	0	0	0	0
PipesOpen (byte values)	0x0D								0x00							
PipesClosed (bits)	1	0	0	0	0	0	1	0	0	0	0	1	0	0	0	1
PipesClosed (byte values)	0x82								0x11							
Bitmap bytes	Byte 5								Byte 6							
Service pipe number	39	38	37	36	35	34	33	32	47	46	45	44	43	42	41	40
PipesOpen (bits)	0	0	0	0	0	0	0	0	0	0	0	0	0	0	0	0
PipesOpen (byte values)	0x00								0x00							
PipesClosed (bits)	0	0	0	0	0	0	0	0	0	0	0	1	0	0	0	0
PipesClosed (byte values)	0x00								0x10							
Bitmap bytes	Byte 7								Byte 8							
Service pipe number	55	54	53	52	51	50	49	48	63	62	61	60	59	58	57	56
PipesOpen (bits)	0	0	0	0	1	0	0	0	0	0	0	0	0	0	0	0
PipesOpen (byte values)	0x08								0x00							
PipesClosed (bits)	0	0	0	0	0	0	0	0	0	0	0	0	0	0	0	0
PipesClosed (byte values)	0x00								0x00							

Table 98. Bitmap returned by `PipeStatusEvent` (Example)

26.8.2 Message format

Message field/parameter	Value size (bytes)	Data value	Description
Header			
Length	1	17	Packet length
Event	1	0x88	<code>PipeStatusEvent</code>
Content			
PipesOpen	8		Bitmap of open service pipes, 1...62
PipesClosed	8		Bitmap of service pipes that will require opening (<code>OpenRemotePipe</code>) before they are operational, 1...62

Table 99. ACI message structure for `PipeStatusEvent`

26.8.3 Returned values

Parameter	Data value	Description
<i>PipesOpen</i>	-	<p>Bitmap where each of the bits 1 to 62 represents the service pipes with the number 1 to 62. Bit 63 is not in use. A "1" means that the corresponding pipe is open, while a "0" means that the pipe is unavailable.</p> <p>Bit 0 in the first byte contains the nRF8001 service discovery procedure execution status:</p> <ul style="list-style-type: none"> • When set to 1, the nRF8001 initiated service discovery procedure has completed. • When set to 0, the nRF8001 initiated service discovery has not yet completed¹.
<i>PipesClosed</i>	-	<p>Bitmap where each of the bits 1 to 62 represents the service pipes with the number 1 to 62. Bit 63 is not in use. A "1" means that the corresponding pipe requires opening, while a "0" means that no action is required. Bit 0 in the first byte contains is always set to "0"</p>

1. If service discovery is not required for nRF8001 (based on the existing service configuration), Bit 0 in the first bitmap byte is set to 1.

Table 100. Returned values for PipeStatusEvent

26.8.4 Bluetooth low energy procedures used

None

26.9 TimingEvent (0x89)

TimingEvent returns the current connection timing information upon change of parameters.

26.9.1 Functional description

This event is sent from nRF8001 to the external application controller when nRF8001 connects to a peer device or when the connection parameters are updated by a device in the central role.

26.9.2 Message format

Message field/parameter	Value size (bytes)	Data value	Description
Header			
Length	1	7	Packet length
Event	1	0x89	TimingEvent
Content			
<i>ConnectionInterval</i>	2		Connection interval for the actual connection (MSB first)
<i>SlaveLatency</i>	2		Slave latency setting (LSB/MSB)
<i>SupervisionTimeout</i>	2		Supervision timeout for the connection (multiple of 10 ms)

Table 101. ACI message structure for TimingEvent

26.9.3 Returned values

Parameter	Data value	Description
<i>ConnectionInterval</i>	6..3200	Connection interval = data value multiplied by 1,25ms
<i>SlaveLatency</i>	0..1000 (0x0000 - 0x03E8)	The number of consecutive connection events that the slave is not required to respond
<i>SupervisionTimeout</i>	10..3200	Timeout = data value multiplied by 10ms

Table 102. Returned values for TimingEvent

26.9.4 Bluetooth low energy procedures used

None

26.10 DisplayKeyEvent (0x8E)

DisplayKeyEvent requests the application controller to display the 6 digit passkey.

26.10.1 Functional Description

DisplayKeyEvent is used as part of the pairing procedure. If Man In The Middle (MITM) security and applicable IO capabilities for the peripheral application as defined in [Table 5. on page 31](#) are set then this event is generated. Device configuration must be completed before DisplayKeyEvent is available.

26.10.2 Message Format

Message field/ parameter	Value size (bytes)	Data value	Description
Header			
Length	1	7	
Command	1	0x8E	DisplaykeyEvent
Content			
<i>Passkey</i>	6		The passkey to be displayed

Table 103. ACI message structure for DisplayKeyEvent

26.10.3 Accepted values

Parameter	Data value	Description
<i>Passkey</i>		A fixed 6 byte ASCII string representing the passkey (no NULL termination, '0'-'9' digits only) The number has to be padded with zeroes if shorter than six digits. Examples: "000123", "999999", "000000"

Table 104. Accepted values for parameters, DisplayKeyEvent

26.10.4 Returned events

None

26.10.5 Bluetooth low energy procedures used

This command uses the following GAP procedure:

- *Bluetooth* Specification, v. 4.0, Vol 3, Part C, Sect. 10

26.11 KeyRequestEvent (0x8F)

KeyRequestEvent requests the application controller to enter the passkey.

26.11.1 Functional Description

KeyRequestEvent is used as part of the pairing procedure. If MITM security and applicable IO capabilities for the peripheral application as defined in [Table 5. on page 31](#) are set then this event is generated. Device configuration must be completed before KeyRequestEvent is available.

The application controller must send the SetKey command (see [section 24.21 on page 123](#)) after receiving this event. The SetKey command must be sent from the application controller to nRF8001 within 30 seconds of the KeyRequestEvent being received. When the SetKey command is not sent within 30 seconds the bonding will fail and the link will be terminated.

26.11.2 Message Format

Message field/ parameter	Value size (bytes)	Data value	Description
Header			
Length	1	2	
Command	1	0x8F	KeyRequestEvent
Content			
Key Type	1		Which key is requested

Table 105. ACI message structure for KeyRequestEvent

26.11.3 Accepted values

Parameter	Data value	Description
KeyType	0x01	Passkey requested

Table 106. Accepted values for parameters, KeyRequestEvent

26.11.4 Returned events

None

26.11.5 Bluetooth low energy procedures used

This command uses the following GAP procedure:

- *Bluetooth* Specification, v. 4.0, Vol 3, Part C, Sect. 10

27 Data Events

Data events are information packets related to application data transfer sent from nRF8001 to the application controller.

27.1 DataCreditEvent (0x8A)

DataCreditEvent returns data command buffer credits.

27.1.1 Functional description

This returns the number of data command buffer locations (credits) freed as a result of successful data command execution(s).

27.1.2 Message format

Message field/parameter	Value size (bytes)	Data value	Description
Header			
Length	1	2	Packet length
Event	1	0x8A	DataCreditEvent
Content			
DataCredits	1		Returned credits

Table 107. ACI message structure for DataCreditEvent

27.1.3 Returned values

Parameter	Data value	Description
DataCredits		The number of data credits returned to the application controller.

Table 108. Returned values for DataCreditEvent

27.1.4 Bluetooth low energy procedures used

None

27.2 PipeErrorEvent (0x8D)

PipeErrorEvent reports a pipe transmission failure/error.

27.2.1 Functional description

This event is sent from nRF8001 to the external application controller in the case of transmission failure.

27.2.2 Message format

Message field/parameter	Value size (bytes)	Data value	Description
Header			
Length	1	3..30	Packet length
Event	1	0x8D	PipeErrorEvent
Content			
<i>ServicePipeNo</i>	1		Pipe number of the pipe of which the error occurred
<i>ErrorCode</i>	1		Status error code
<i>ErrorData</i>	0..27		Optional error data

Table 109. ACI message structure for PipeErrorEvent

27.2.3 Returned values

Parameter	Data value	Description
<i>ServicePipeNo</i>	1..62	Refers to a valid pipe number listed in the OpenPipes/ClosedPipes bitmaps returned in the PipeStatusEvent
<i>ErrorCode</i>	0x01 – 0xFF	Status error code. See chapter 28 on page 157 for a comprehensive list of error codes.
<i>ErrorData</i>	-	Optional error data, 0 to 27 bytes depending on error code.

Table 110. Returned values for parameters, PipeErrorEvent

27.2.4 Bluetooth low energy procedures used

None

27.3 DataReceivedEvent (0x8C)

DataReceivedEvent indicates that data has been received from the peer device

27.3.1 Functional description

This event is sent from nRF8001 to the external application controller when new data is received on a receive service pipe.

27.3.2 Message format

Message field/parameter	Value size (bytes)	Data value	Description
Header			
Length	1	2..22	Packet length
Event	1	0x8C	DataReceivedEvent
Content			
ServicePipeNo	1		ID of the service pipe through which data is received
Data	0..20		Application data

Table 111. ACI message structure for DataReceivedEvent

27.3.3 Returned values

Parameter	Data value	Description
<i>ServicePipeNo</i>	1..62	Refers to a valid pipe number listed in the OpenPipes bitmap returned in the PipeStatusEvent
<i>Data</i>	n	The data payload size must not exceed the maximum length defined in the local server

Table 112. Returned values for DataReceivedEvent

27.3.4 Bluetooth low energy procedures used

None

27.4 DataAckEvent (0x8B)

DataAckEvent indicates reception of data by the peer device

27.4.1 Functional description

This event is sent from nRF8001 to the application controller when an acknowledgment is received from the peer device in response to data sent to it.

27.4.2 Message format

Message field/parameter	Value size (bytes)	Data value	Description
Header			
Length	1	2	Packet length
Event	1	0x8B	DataAckEvent
Content			
ServicePipeNumber	1		Pipe number of the pipe on which the Ack was received

Table 113. ACI message structure for DataAckEvent

27.4.3 Returned values

Parameter	Data value	Description
ServicePipeNumber	1..62	Refers to a valid pipe number listed in the OpenPipes bitmap returned in the PipeStatusEvent

Table 114. Returned values for DataAckEvent

27.4.4 Bluetooth low energy procedures used

None

28 Appendix

28.1 ACI Status Codes

[Table 115](#) lists the generic ACI status codes applicable for nRF8001. The status code is used to indicate the general command execution status or to identify the cause of an error.

Status code	Name	Description
0x00	ACI_STATUS_SUCCESS	Success
0x01	ACI_STATUS_TRANSACTION_CONTINUE	Transaction continuation status
0x02	ACI_STATUS_TRANSACTION_COMPLETE	Transaction completed
0x03	ACI_STATUS_EXTENDED	Extended status, further checks needed
0x80	ACI_STATUS_ERROR_UNKNOWN	Unknown error
0x81	ACI_STATUS_ERROR_INTERNAL	Internal error
0x82	ACI_STATUS_ERROR_CMD_UNKNOWN	Unknown command
0x83	ACI_STATUS_ERROR_DEVICE_STATE_INVALID	Command invalid in the current device state
0x84	ACI_STATUS_ERROR_INVALID_LENGTH	Invalid length
0x85	ACI_STATUS_ERROR_INVALID_PARAMETER	Invalid input parameters
0x86	ACI_STATUS_ERROR_BUSY	Busy
0x87	ACI_STATUS_ERROR_INVALID_DATA	Invalid data format or contents
0x88	ACI_STATUS_ERROR_CRC_MISMATCH	CRC mismatch
0x89	ACI_STATUS_ERROR_UNSUPPORTED_SETUP_FORMAT	Unsupported setup format
0x8A	ACI_STATUS_ERROR_INVALID_SEQ_NO	Invalid sequence number during a write dynamic data sequence
0x8B	ACI_STATUS_ERROR_SETUP_LOCKED	Setup data is locked and cannot be modified
0x8C	ACI_STATUS_ERROR_LOCK_FAILED	Setup error due to lock verification failure
0x8D	ACI_STATUS_ERROR_BOND_REQUIRED	Bond required: Local service pipes need bonded/trusted peer
0x8E	ACI_STATUS_ERROR_REJECTED	Command rejected as a transaction is still pending
0x8F	ACI_STATUS_ERROR_DATA_SIZE	Pipe Error Event : Data size exceeds size specified for pipe, Transmit failed
0x90	ACI_STATUS_ERROR_PIPE_INVALID	Pipe Error Event : Transmit failed, Invalid or unavailable Pipe number or unknown pipe type
0x91	ACI_STATUS_ERROR_CREDIT_NOT_AVAILABLE	Pipe Error Event : Credit not available
0x92	ACI_STATUS_ERROR_PEER_ATT_ERROR	Pipe Error Event : Peer device has sent an error on an pipe operation on the remote characteristic
0x93	ACI_STATUS_ERROR_ADVT_TIMEOUT	Connection was not established before the BTLE advertising was stopped
0x94	ACI_STATUS_ERROR_PEER_SMP_ERROR	Remote device triggered a Security Manager Protocol error
0x95	ACI_STATUS_ERROR_PIPE_TYPE_INVALID	Pipe Error Event: Pipe type invalid for the selected operation

Status code	Name	Description
0x96	ACI_STATUS_ERROR_PIPE_STATE_INVALID	Pipe Error Event: Pipe state invalid for the selected operation
0x97	ACI_STATUS_ERROR_INVALID_KEY_SIZE	Invalid key size provided
0x98	ACI_STATUS_ERROR_INVALID_KEY_DATA	Invalid key data provided

Table 115. nRF8001 ACI Status codes

28.2 Bonding Status Codes

[Table 116](#) lists the status codes applicable for the `BondStatusEvent`. The status code is used to report the bonding procedure execution status.

Bond status code	Name	Description
0x00	ACI_BOND_STATUS_SUCCESS	Bonding succeeded
0x01	ACI_BOND_STATUS_FAILED	Bonding failed
0x02	ACI_BOND_STATUS_FAILED_TIMED_OUT	Bonding error: Timeout while bonding
0x81	ACI_BOND_STATUS_FAILED_PASSKEY_ENTRY_FAILED	Bonding error: Passkey entry failed
0x82	ACI_BOND_STATUS_FAILED_OOB_UNAVAILABLE	Bonding error: OOB unavailable
0x83	ACI_BOND_STATUS_FAILED_AUTHENTICATION_REQ	Bonding error: Authentication request failed
0x84	ACI_BOND_STATUS_FAILED_CONFIRM_VALUE	Bonding error: Confirm value failed
0x85	ACI_BOND_STATUS_FAILED_PAIRING_UNSUPPORTED	Bonding error: Pairing unsupported
0x86	ACI_BOND_STATUS_FAILED_ENCRYPTION_KEY_SIZE	Bonding error: Invalid encryption key size
0x87	ACI_BOND_STATUS_FAILED_SMP_CMD_UNSUPPORTED	Bonding error: Unsupported SMP command
0x88	ACI_BOND_STATUS_FAILED_UNSPECIFIED_REASON	Bonding error: Unspecified reason
0x89	ACI_BOND_STATUS_FAILED_REPEATED_ATTEMPTS	Bonding error: Too many attempts
0x8A	ACI_BOND_STATUS_FAILED_INVALID_PARAMETERS	Bonding error: Invalid parameters

Table 116. Bonding status codes

28.3 Error Codes

[Table 117](#) lists the status codes applicable for the `PipeErrorEvent`. The error code is used to report an error related to data transfer or service pipe association.

Refer to the *Bluetooth* specification for the latest set of error codes.³⁴

Bond status code	Name	Description
Invalid Handle	0x01	The attribute handle given was not valid on this server
Read Not Permitted	0x02	The attribute cannot be read.
Write Not Permitted	0x03	The attribute cannot be written.
Invalid PDU	0x04	The attribute PDU was invalid.
Insufficient Authentication	0x05	The attribute requires authentication before it can be read or written.
Request Not Supported	0x06	Attribute server does not support the request received from the client.
Invalid Offset	0x07	Offset specified was past the end of the attribute.
Insufficient Authorization	0x08	The attribute requires authorization before it can be read or written.
Prepare Queue Full	0x09	Too many prepare writes have been queued.
Attribute Not Found	0x0A	No attribute found within the given attribute handle range.
Attribute Not Long	0x0B	The attribute cannot be read or written using the Read Blob Request
Insufficient Encryption Key Size	0x0C	The Encryption Key Size used for encrypting this link is insufficient.
Invalid Attribute Value Length	0x0D	The attribute value length is invalid for the operation.
Unlikely Error	0x0E	The attribute request that was requested has encountered an error that was unlikely, and therefore could not be completed as requested.
Insufficient Encryption	0x0F	The attribute requires encryption before it can be read or written.
Unsupported Group Type	0x10	The attribute type is not a supported grouping attribute as defined by a higher layer specification.
Insufficient Resources	0x11	Insufficient Resources to complete the request
Application Error	0x80-0xFF	Application error code defined by a higher layer specification.

Table 117. Attribute error codes used in the `PipeErrorEvent`

34. *Bluetooth* specification Ver. 4.0, Vol. 3, Part F, Chapter 3.4, Table 3.3, 'Error codes'

29 Glossary

Term	Description
ACI	Application Controller Interface
CCCD	Client Characteristic Configuration Descriptor
CSRK	Connection Signature Resolving Key
DTM	Direct Test Mode
EDIV	Encrypted Diversifier
EOC	Extreme Operating Conditions
EP-QDL	End Product Qualified Design Listing
ESR	Equivalent Series Resistance
HV	Handle Value
IMD	Intermodulation Distortion
IRK	Identity Root Key
LTK	Long Term Key
MD	More Data
MOQ	Minimum Order Quantity
MCU	Microcontroller
MSC	Message Sequence Chart
NOC	Nominal Operating Conditions
NVM	Non-Volatile Memory
OOD	Out Of Range
PCB	Printed Circuit Board
PDU	Protocol Data Unit
PICS	Protocol Implementation Conformance Statement
PUID	Personal User Interface Device
RF	Radio Frequency
RoHS	Restriction of Hazardous Substances
SDK	Software Development Kit
UART	Universal Asynchronous Receiver Transmitter
VM	Volatile Memory

Mouser Electronics

Authorized Distributor

Click to View Pricing, Inventory, Delivery & Lifecycle Information:

[Nordic Semiconductor:](#)

[nRF8001-R2Q32-R](#) [nRF8001-R2Q32-R7](#) [nRF8001-R2Q32-T](#)



Компания «ЭлектроПласт» предлагает заключение долгосрочных отношений при поставках импортных электронных компонентов на взаимовыгодных условиях!

Наши преимущества:

- Оперативные поставки широкого спектра электронных компонентов отечественного и импортного производства напрямую от производителей и с крупнейших мировых складов;
- Поставка более 17-ти миллионов наименований электронных компонентов;
- Поставка сложных, дефицитных, либо снятых с производства позиций;
- Оперативные сроки поставки под заказ (от 5 рабочих дней);
- Экспресс доставка в любую точку России;
- Техническая поддержка проекта, помощь в подборе аналогов, поставка прототипов;
- Система менеджмента качества сертифицирована по Международному стандарту ISO 9001;
- Лицензия ФСБ на осуществление работ с использованием сведений, составляющих государственную тайну;
- Поставка специализированных компонентов (Xilinx, Altera, Analog Devices, Intersil, Interpoint, Microsemi, Aeroflex, Peregrine, Syfer, Eurofarad, Texas Instrument, Miteq, Cobham, E2V, MA-COM, Hittite, Mini-Circuits, General Dynamics и др.);

Помимо этого, одним из направлений компании «ЭлектроПласт» является направление «Источники питания». Мы предлагаем Вам помощь Конструкторского отдела:

- Подбор оптимального решения, техническое обоснование при выборе компонента;
- Подбор аналогов;
- Консультации по применению компонента;
- Поставка образцов и прототипов;
- Техническая поддержка проекта;
- Защита от снятия компонента с производства.



Как с нами связаться

Телефон: 8 (812) 309 58 32 (многоканальный)

Факс: 8 (812) 320-02-42

Электронная почта: org@eplast1.ru

Адрес: 198099, г. Санкт-Петербург, ул. Калинина, дом 2, корпус 4, литера А.