

# Non-Magnetic Connectors

## Product Catalog



## Table of Contents

	PAGE
Terms and Conditions .....	3-4
Introduction .....	5
MMCX Non-Magnetic RF Connectors .....	6-8
MCX Non-Magnetic RF Connectors .....	9-11
SMA Non-Magnetic RF Connectors .....	12-15
SMB Non-Magnetic RF Connectors .....	16-18
Type N Non-Magnetic RF Connectors .....	19-21
Assembly Instructions .....	22-29
The Johnson Combination - MRI Connectors and Modular Customization .....	30
Competitor Cross Reference .....	31

## Emerson Network Power Connectivity Solutions, Inc. TERMS AND CONDITIONS OF SALE

Emerson Network Power Connectivity Solutions, Inc. is herein referred to as the "Seller" and the customer or person or entity purchasing goods ("Goods") from Seller is referred to as the "Buyer." These Terms and Conditions, any price list or schedule, quotation, acknowledgment or invoice from Seller relevant to the sale of the Goods and all documents incorporated by specific reference herein or therein, constitute the complete and exclusive statement of the terms of the agreement governing the sale of Goods by Seller to Buyer. Buyer's acceptance of the Goods will manifest Buyer's assent to these Terms and Conditions. Seller reserves the right in its sole discretion to refuse orders.

**1. PRICES:** Unless otherwise specified in writing by Seller, the price quoted or specified by Seller for the Goods shall remain in effect for thirty (30) days after the date of Seller's quotation or acknowledgment of Buyer's order for the Goods, whichever occurs first, provided an unconditional authorization from Buyer for the shipment of the Goods is received and accepted by Seller within such time period. If such authorization is not received by Seller within such thirty (30) day period, Seller shall have the right to change the price for the Goods to Seller's price for the Goods at the time of shipment. All prices are exclusive of taxes, transportation and insurance, which are to be borne by Buyer.

**2. TAXES:** Any current or future tax or governmental charge (or increase in same) affecting Seller's costs of production, sale, or delivery or shipment, or which Seller is otherwise required to pay or collect in connection with the sale, purchase, delivery, storage, processing, use or consumption of Goods, shall be for Buyer's account and shall be added to the price.

**3. TERMS OF PAYMENT:** Unless otherwise specified by Seller, terms are net thirty (30) days from date of Seller's invoice in U.S. currency. Seller shall have the right, among other remedies, either to terminate this agreement or to suspend further performance under this and/or other agreements with Buyer in the event Buyer fails to make any payment when due, which other agreements Buyer and Seller hereby amend accordingly. Buyer shall be liable for all expenses, including attorneys' fees, relating to the collection of past due amounts. If any payment owed to Seller is not paid when due, it shall bear interest, at a rate to be determined by Seller, which shall not exceed the maximum rate permitted by law, from the date on which it is due until it is paid. Should Buyer's financial responsibility become unsatisfactory to Seller, cash payments or security satisfactory to Seller may be required by Seller for future deliveries and for the Goods theretofore delivered. If such cash payment or security is not provided, in addition to Seller's other rights and remedies, Seller may discontinue deliveries.

**4. SHIPMENT AND DELIVERY:** While Seller will use all reasonable commercial efforts to maintain the delivery date(s) acknowledged or quoted by Seller, all shipping dates are approximate and not guaranteed. Seller reserves the right to make partial shipments. Seller, at its option, shall not be bound to tender delivery of any Goods for which Buyer has not provided shipping instructions and other required information. If the shipment of the Goods is postponed or delayed by Buyer for any reason, Buyer agrees to reimburse Seller for any and all storage costs and other additional expenses resulting therefrom. Risk of loss and legal title to the Goods shall transfer to Buyer for sales in which the end destination of the Goods is outside of the United States immediately after the Goods have passed beyond the territorial limits of the United States. For all other shipments, risk of loss for damage and responsibility shall pass from Seller to Buyer upon delivery to and receipt by carrier at Seller's shipping point. All shipments are F.O.B. Seller's shipping point. Any claims for shortages or damages suffered in transit are the responsibility of Buyer and shall be submitted by Buyer directly to the carrier. Shortages or damages must be identified and signed for at the time of delivery. Buyer shall inspect Goods delivered to it by Seller immediately upon receipt, and, any course of dealing to the contrary notwithstanding, failure of Buyer to give Seller notice of any claim within 30 days after receipt of such Goods shall be an unqualified acceptance of such Goods.

**5. LIMITED WARRANTY:** Subject to the limitations of Section 6, Seller warrants that the Goods manufactured by Seller will be free from defects in material and workmanship under normal use and regular service and maintenance for a period of one year from the date of shipment of the Goods by Seller, unless otherwise specified by Seller in writing. THIS IS THE SOLE AND EXCLUSIVE WARRANTY GIVEN BY SELLER WITH RESPECT TO THE GOODS AND IS IN LIEU OF AND EXCLUDES ALL OTHER WARRANTIES, EXPRESS OR IMPLIED, ARISING BY OPERATION OF LAW OR OTHERWISE, INCLUDING WITHOUT LIMITATION, MERCHANTABILITY AND FITNESS FOR A PARTICULAR PURPOSE WHETHER OR NOT THE PURPOSE OR USE HAS BEEN

DISCLOSED TO SELLER IN SPECIFICATIONS, DRAWINGS OR OTHERWISE, AND WHETHER OR NOT SELLER'S PRODUCTS ARE SPECIFICALLY DESIGNED AND/OR MANUFACTURED BY SELLER FOR BUYER'S USE OR PURPOSE.

This warranty does not extend to any losses or damages due to misuse, accident, abuse, neglect, normal wear and tear, negligence (other than Seller's), unauthorized modification or alteration, use beyond rated capacity, unsuitable power sources or environmental conditions, improper installation, repair, handling, maintenance or application or any other cause not the fault of Seller. To the extent that Buyer or its agents has supplied specifications, information, representation of operating conditions or other data to Seller in the selection or design of the Goods and the preparation of Seller's quotation, and in the event that actual operating conditions or other conditions differ from those represented by Buyer, any warranties or other provisions contained herein which are affected by such conditions shall be null and void.

If within thirty (30) days after Buyer's discovery of any warranty defects within the warranty period, Buyer notifies Seller thereof in writing, Seller shall, at its option and as Buyer's exclusive remedy, repair, correct or replace F.O.B. point of manufacture, or refund the purchase price for, that portion of the Goods found by Seller to be defective. Failure by Buyer to give such written notice within the applicable time period shall be deemed an absolute and unconditional waiver of Buyer's claim for such defects. All costs of dismantling, reinstallation and freight and the time and expense of Seller's personnel and representatives for site travel and diagnosis under this warranty shall be borne by Buyer unless accepted in writing by Seller. Goods repaired or replaced during the warranty period shall be covered by the foregoing warranty for the remainder of the original warranty period or ninety (90) days from the date of shipment, whichever is longer.

Buyer assumes all other responsibility for any loss, damage, or injury to persons or property arising out of, connected with, or resulting from the use of Goods, either alone or in combination with other products/components.

Section 5 applies to any entity or person who may buy, acquire or use the Goods, including any entity or person who obtains the Goods from Buyer, and shall be bound by the limitations therein, including Section 6. Buyer agrees to provide such subsequent transferee conspicuous, written notice of the provisions of Sections 5 and 6.

**6. LIMITATION OF REMEDY AND LIABILITY:** THE SOLE AND EXCLUSIVE REMEDY FOR BREACH OF ANY WARRANTY HEREUNDER OTHER THAN THE WARRANTY PROVIDED UNDER SECTION 7 SHALL BE LIMITED TO REPAIR, CORRECTION OR REPLACEMENT, OR REFUND OF THE PURCHASE PRICE UNDER SECTION 5.

SELLER SHALL NOT BE LIABLE FOR DAMAGES CAUSED BY DELAY IN PERFORMANCE AND THE REMEDIES SET FORTH IN THIS AGREEMENT ARE EXCLUSIVE. IN NO EVENT, REGARDLESS OF THE FORM OF THE CLAIM OR CAUSE OF ACTION (WHETHER BASED IN CONTRACT, INFRINGEMENT, NEGLIGENCE, STRICT LIABILITY, OTHER TORT OR OTHERWISE), SHALL SELLER'S LIABILITY TO BUYER AND/OR ITS CUSTOMERS EXCEED THE PRICE PAID BY BUYER FOR THE SPECIFIC GOODS PROVIDED BY SELLER GIVING RISE TO THE CLAIM OR CAUSE OF ACTION. BUYER AGREES THAT IN NO EVENT SHALL SELLER'S LIABILITY TO BUYER AND/OR ITS CUSTOMERS EXTEND TO INCLUDE INCIDENTAL, CONSEQUENTIAL OR PUNITIVE DAMAGES. The term "consequential damages" shall include, but not be limited to, loss of anticipated profits, business interruption, loss of use, revenue, reputation and data, costs incurred, including without limitation, for capital, fuel, power and loss or damage to property or equipment.

Buyer expressly acknowledges and agrees that Seller has set its prices and entered into this agreement in reliance upon the limitations of liability and other terms and conditions specified herein, which allocates the risk between Seller and Buyer and form a basis of this bargain between the parties. It is expressly understood that any technical advice furnished by Seller with respect to the use of the Goods is given without charge, and Seller assumes no obligation or liability for the advice given, or results obtained, all such advice being given and accepted at Buyer's risk.

**7. PATENTS AND COPYRIGHTS:** Subject to the limitations of the second paragraph of Section 6, Seller warrants that the Goods sold, except as are made specifically for Buyer according to Buyer's specifications, do not infringe any valid U.S. patent or copyright in existence as of the date of shipment. This warranty is given upon the

condition that Buyer promptly notify Seller of any claim or suit involving Buyer in which such infringement is alleged and cooperate fully with Seller and permit Seller to control completely the defense, settlement or compromise of any such allegation of infringement. Seller's warranty as to use patents only applies to infringement arising solely out of the inherent operation according to Seller's specifications and instructions (i) of such Goods, or (ii) of Emerson Network Power Connectivity Solutions, Inc. any combination of Goods acquired from Seller in a system designed by Seller. In the event such Goods are held to infringe such a U.S. patent or copyright in such suit, and the use of such Goods is enjoined, or in the case of a compromise or settlement by Seller, Seller shall have the right, at its option and expense, to procure for Buyer the right to continue using such Goods, or replace them with non-infringing Goods, or modify same to become non-infringing, or grant Buyer a credit for the depreciated value of such Goods and accept return of them. In the event of the foregoing, Seller may also, at its option, cancel the agreement as to future deliveries of such Goods, without liability.

**8. EXCUSE OF PERFORMANCE:** Seller shall not be liable for delays in performance or for non-performance due to acts of God; acts of Buyer; war; fire; flood; weather; sabotage; strikes or labor disputes; civil disturbances or riots; governmental requests, restrictions, allocations, laws, regulations, orders or actions; unavailability of or delays in transportation; default of suppliers; or unforeseen circumstances or any events or causes beyond Seller's reasonable control. Deliveries or other performance may be suspended for an appropriate period of time or canceled by Seller upon notice to Buyer in the event of any of the foregoing, but the balance of the agreement shall otherwise remain unaffected as a result of the foregoing.

If Seller determines that its ability to supply the total demand for the Goods, or to obtain material used directly or indirectly in the manufacture of the Goods, is hindered, limited or made impracticable due to causes set forth in the preceding paragraph, Seller may allocate its available supply of the Goods or such material without obligation to acquire other supplies of any such Goods or material among itself and its purchasers on such basis as Seller determines to be equitable without liability for any failure of performance which may result therefrom.

**9. CANCELLATION:** Unless otherwise agreed in writing by Seller, orders under this agreement may not be canceled by Buyer for any reason.

**10. CHANGES:** Buyer may request changes or additions to the Goods consistent with Seller's specifications and criteria. In the event such changes or additions are accepted by Seller, Seller may revise the price and dates of delivery.

Seller reserves the right to change designs and specifications for the Goods without prior notice to Buyer, except with respect to Goods being made-to-order for Buyer. Seller shall have no obligation to install or make such change in any Goods manufactured prior to the date of such change.

**11. NUCLEAR/MEDICAL:** GOODS AND SERVICES SOLD HEREUNDER ARE NOT FOR USE IN CONNECTION WITH ANY NUCLEAR, MEDICAL, LIFESUPPORT AND RELATED APPLICATIONS. Buyer accepts goods and services with the foregoing understanding, agrees to communicate the same in writing to any subsequent purchasers or users and to defend, indemnify and hold harmless Seller from any claims, losses, suits, judgments and damages, including incidental and consequential damages, arising from such use, whether the cause of action be based in tort, contract or otherwise, including allegations that the Seller's liability is based on negligence or strict liability.

**12. BUYER'S COMPLIANCE WITH LAWS:** In connection with the transactions contemplated by this agreement, Buyer is familiar with and shall fully comply with all applicable laws, regulations, rules and other requirements of the United States and of any applicable state, foreign and local governmental body in connection with the purchase, receipt, use, transfer and disposal of the Goods.

**13. EXPORT/IMPORT:** Buyer agrees that all applicable import and export control laws, regulations, orders and requirements, including without limitation those of the United States and the European Union, and the jurisdictions in which the Seller and Buyer are established or from which Goods and Services may be supplied, will apply to their receipt and use. In no event shall Buyer use, transfer, release, import, export, Goods in violation of such applicable laws, regulations, orders or requirements.

**14. TOOLING:** Tool, die, and pattern charges, if any, are in addition to the price of the Goods and are due and payable upon completion of the tooling. All such tools, dies and patterns shall be and remain the property of Seller. Charges for tools, dies, and

patterns do not convey to Buyer, title, ownership interest in, or rights to possession or removal, or prevent their use by Seller for other purchasers, except as otherwise expressly provided by Seller and Buyer in writing with reference to this provision.

**15. RETURNED GOODS:** Except as otherwise provided with respect to warranty defects in Section 5, advance written permission to return Goods must be obtained from Seller's customer service department. Such Goods must be current, unused, catalogued Goods and must be shipped, transportation prepaid, to the Seller's specified return location. Returns made without proper written permission will not be accepted by Seller. Credit or exchange for such returned Goods will be at the billing price or current price, whichever is lower, from which will be deducted an inspection, restocking and repacking charge and the cost of any reconditioning. Seller reserves the right to inspect Goods prior to authorizing return.

**16. BUYER SUPPLIED DATA:** To the extent that Seller has been provided by or on behalf of Buyer any specifications, description of operating conditions or other data and information in connection with the selection or design of the Goods, and the actual operating conditions or other circumstances differ from those provided by Buyer and relied upon by Seller, any warranties or other provisions contained herein which are affected by such conditions shall be null and void.

**17. DRAWINGS:** Seller's prints and drawings (including without limitation, the underlying technology) furnished by Seller to Buyer in connection with this agreement are the property of Seller and Seller retains all rights, including without limitation, exclusive rights of use, licensing and sale. Possession of such prints or drawings does not convey to Buyer any rights or license, and Buyer shall return all copies (in whatever medium) of such prints or drawings to Seller immediately upon request therefore.

**18. ASSIGNMENT:** Buyer shall not assign its rights or delegate its duties hereunder or any interest herein without the prior written consent of Seller, and any such assignment, without such consent, shall be void.

**19. GENERAL PROVISIONS:** These terms and conditions supersede all other communications, negotiations and prior oral or written statements regarding the subject matter of these terms and conditions. No change, modification, rescission, discharge, abandonment, or waiver of these terms and conditions shall be binding upon the Seller unless made in writing and signed on its behalf by a duly authorized representative of Seller. No conditions, usage of trade, course of dealing or performance, understanding or agreement purporting to modify, vary, explain, or supplement these terms and conditions shall be binding unless hereafter made in writing and signed by the party to be bound, and no modification or additional terms shall be applicable to this agreement by Seller's receipt, acknowledgment, or acceptance of purchase orders, shipping instruction forms, or other documentation containing terms at variance with or in addition to those set forth herein. Any such modifications or additional terms are specifically rejected and deemed a material alteration hereof. If this document shall be deemed an acceptance of a prior offer by Buyer, such acceptance is expressly conditional upon Buyer's assent to any additional or different terms set forth herein. No waiver by either party with respect to any breach or default or of any right or remedy, and no course of dealing, shall be deemed to constitute a continuing waiver of any other breach or default or of any other right or remedy, unless such waiver be expressed in writing and signed by the party to be bound. All typographical or clerical errors made by Seller in any quotation, acknowledgment or publication are subject to correction.

The validity, performance, and all other matters relating to the interpretation and effect of this agreement shall be governed by the law of the state of Missouri. Buyer and Seller agree that the proper venue for all actions arising in connection herewith shall be only in Missouri and the parties agree to submit to such jurisdiction. No action, regardless of form, arising out of transactions relating to this contract, may be brought by either party more than two (2) years after the cause of action has accrued. The U.N. Convention on Contracts for the International Sales of Goods shall not apply to this agreement.

# Johnson's Non-Magnetic Connector Additions Offer Solutions to MR Imaging Technology

Johnson®, a product line of Emerson Network Power Connectivity Solutions, has added two new connector product groups to its popular line of Non-Magnetic RF coaxial connectors and cable assemblies.

MMCX micro-miniature connectors have been added to satisfy the needs of the RF coil manufacturers that are building smaller coils for MRI equipment. Customized flex coils and array coils can image smaller parts of the body such as wrists, feet, hands and other appendages.

The Non-Magnetic MMCX is the perfect micro-miniature connector for small multichannel coil packages as they provide a positive snap-on coupling design with high mating cycles for rugged, high density connectivity.

The Type N Non-Magnetic connector provides a perfect RF solution for high Tesla fields considered for future designs. These deep tissue MR images will require the rugged interface of the N connector as well as the tri-alloy plating to eliminate inter-modulation issues.

All the connectors in Johnson's Non-Magnetic line are made from high purity copper alloys assuring no ferrous materials are in the connectors manufactured. Emerson Connectivity Solutions continues to work with our customers to develop new solutions as the MR industry transitions to high-end field applications and improved resolution at greater physical depths within the body.

Products are offered through authorized distributors and international sales channels including a direct sales force and a network of manufacturers' representatives. For more information, please call (800) 247-8256.

### About Johnson®

Emerson Network Power Connectivity Solutions, located in Waseca, MN, manufactures Johnson® RF Connectors such as Ultra-miniature (UMC), Micro-miniature (MCX, MCX 75, MMCX and SMP), Sub-miniature (SMA, SMB, SMB Mini-75 Ohm, SMK) and Medium (Type N) in the most popular styles including PC Board Mount, End Launch, Bulkhead Mount and Cable Mounts (Flexible, Semi-rigid and Conformable).

## ELECTRICAL SPECIFICATIONS

**Impedance:** 50 Ohms

**Frequency Range:**

Connectors ..... 0-6 GHz

**VSWR:** (f = GHz)

	Straight Cable Connectors	Right Angle Cable Connectors
.047 dia flexible .....	1.20	1.14 + .07f
RG-178, RG-316, RG-316 DS .....	1.20	1.25

**Working Voltage:**

Connectors ..... 170 VRMS at sea level

**Dielectric Withstanding Voltage:**

Connectors ..... 500 VRMS at sea level

**Insulation Resistance:** 1000 megohms min

**Contact Resistance:** (milliohms maximum)

	Initial	After Environmental
Center contact (straight cabled connectors and uncabled receptacles) .....	5.0	8.0
Center contact (right angle cabled connectors) .....	5.0	15.0
Outer contact (all connectors) .....	1.0	1.5
Braid to body .....	1.5	N/A

**Corona Level:**

Connectors ..... 190 volts min at 70,000 feet

**Insertion Loss:** (dB max tested at 1 GHz)

Straight cabled connectors .....	.0.1
Right angle cabled connectors .....	.0.2
Uncabled receptacles .....	N/A

**RF Leakage:** (dB minimum, tested at 2.5 GHz)

Flexible cable connectors ..... -60 dB

**RF High Potential Withstanding Voltage:**

400 VRMS MIN (tested at 4 and 7 MHz)

## MECHANICAL SPECIFICATIONS

**Engagement Design:** Series MMCX

**Engagement Force:** 8 lbs. max axial engagement, 1.4 lbs. min axial disengagement

**Contact Retention:** 2.0 pounds min. axial force

1 inch-ounce min. torque (uncabled receptacles)

<b>Cable Retention:</b> .....	Axial Force* (lbs)	Torque (in-oz)
Connectors for .047 flexible .....	3.5	N/A
Connectors for RG-178 .....	7.0	N/A
Connectors for RG-316 .....	20.0	N/A
Connectors for RG-316 DS .....	25.0	N/A
Connectors for .086 Semi-Rigid .....	30.0	16

\*Or cable breaking strength whichever is less.

**Durability:** 500 cycles minimum

## ENVIRONMENTAL SPECIFICATIONS

(Meets or Exceeds the Applicable Paragraph of MIL-PRF-39012)

**Temperature Range:**

Connectors ..... -65°C to +165°C

**Thermal Shock:** MIL-STD-202, Method 107, Condition C (except -55° C to +155° C)

**Corrosion:** MIL-STD-202, Method 101, Condition B

**Shock:** MIL-STD-202, Method 213, Condition B

**Vibration:** MIL-STD-202, Method 204, Condition D

**Moisture Resistance:** MIL-STD-202, Method 106

## Straight Crimp Type Plug - Solder or Crimp Contact - Captivated Contact

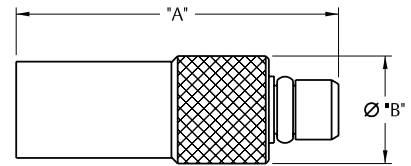

Cable Type	Gold Plated	"A"	"B"	Termination
RG-316/U, 188, 161, 174	135-9403-001	.509 (12.93)	.173 (4.39)	Crimp Sleeve
RG-178/U, 196	135-9402-001	.462 (11.73)	.137 (3.48)	Crimp Insert
.047 Dia. Flex	135-9436-001	.462 (11.73)	.137 (3.48)	Crimp Insert

See assembly instructions page 22

## Right Angle Crimp Type Plug - Captivated Contact

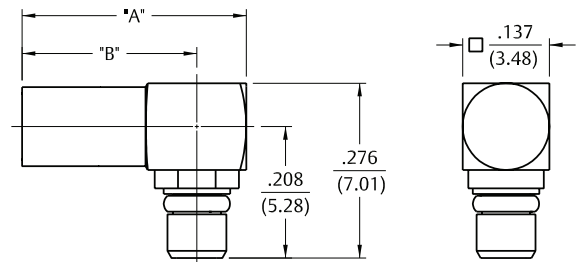

Cable Type	Gold Plated	"A"	"B"	Termination
RG-316/U, 188, 187, 179, 161, 174	135-9403-101	.412 (10.46)	.334 (8.48)	Crimp Sleeve
RG-178/U, 196	135-9402-111	.412 (10.46)	.334 (8.48)	Crimp Sleeve
.047 Dia. Flex	135-9436-101	.354 (8.99)	.276 (6.98)	Crimp Insert

See assembly instructions page 23

## Straight Jack Receptacle

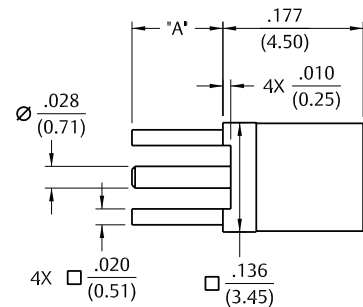

Gold Plated	"A"
135-9701-201	.115 (2.92)
135-9701-211	.068 (1.73)

Mounting hole layout figure 1 on page 8

# MMCX Non-Magnetic RF Connectors For PC Mount

Connectivity for  
Business-Critical Continuity

## Right Angle Jack Receptacle

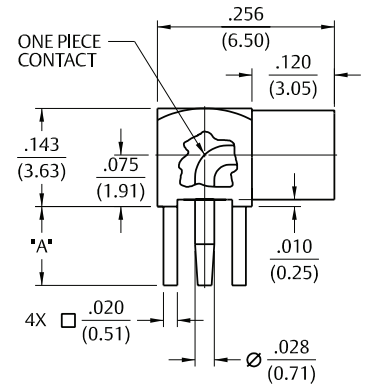

Gold Plated	"A"
135-9701-301	.155 (3.94)
135-9701-311	.068 (1.73)

Mounting hole layout figure 1 on page 8 (below)

## End Launch Jack Receptacle - Surface Contact

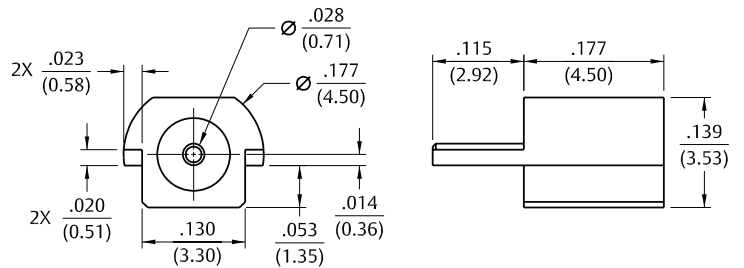

Gold Plated	Packaging
135-9711-801	Stock
135-9711-802	Tape and Reel 1000 pcs/reel

Recommended land pattern figure 2 on page 8 (below)

## MOUNTING HOLE

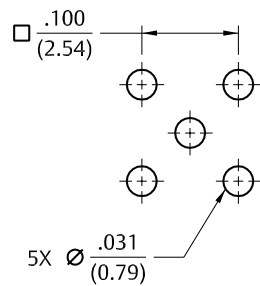

Fig 1

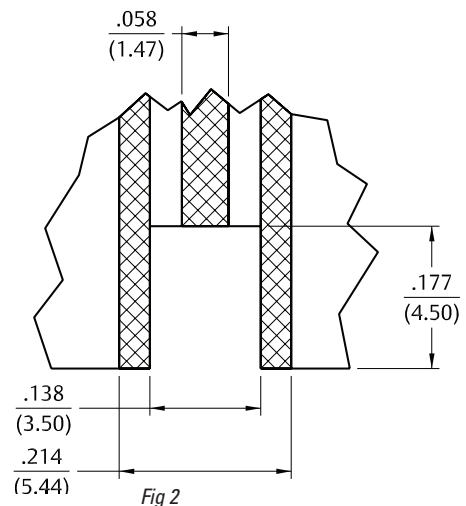

Fig 2



## ELECTRICAL SPECIFICATIONS

**Impedance:** 50 Ohms

**Frequency Range:** .....0-6 GHz

**VSWR:** (f = GHz)

	Straight Cable Connectors	Right Angle Cable Connectors
RG-178 cable	1.17 + .09f	1.07 + .06f
RG-316 cable	1.13 + .04f	1.07 + .04f
Uncabled receptacles	N/A	

**Working Voltage:** (VRMS maximum)

Connectors for Cable Type	Sea Level	70K Feet
RG-178	.250	.65
RG-316	.335	.85

**Dielectric Withstanding Voltage:** (VRMS minimum at sea level)

Connectors for RG-178, uncabled receptacles	.750
Connectors for RG-316, uncabled receptacles	1.000

**Insulation Resistance:** 10,000 megohms minimum

**Contact Resistance:** (milliohms maximum)

	Initial	After Environmental
Center contact (straight cabled connectors, uncabled receptacles)	5.0	8.0
Center contact (right angle cabled connectors)	5.0	15.0
Outer contact	1.0	1.5
Braid to body	1.0	N/A

**Corona Level:** (Volts minimum at 70,000 feet)

Connectors for RG-178 uncabled receptacles	.190
Connectors for RG-316, uncabled receptacles	.250

**Insertion Loss:** (dB maximum, tested at 1 GHz)

Straight cable connectors	0.1 dB
Right angle cable connectors	0.2 dB
Uncabled receptacles	N/A

**RF Leakage:** (dB minimum tested at 2.5 GHz)

Cable connectors	55
Uncabled receptacles	N/A

**RF High Potential Withstanding Voltage:** (VRMS minimum, tested at 4 and 7 MHz)

Connectors for RG 178	.500
Connectors for RG 316	.700
Uncabled receptacles	.600

## MECHANICAL SPECIFICATIONS

**Engagement Design:** Compatible with CECC 22220, Series MCX

**Engagement Force:** 5.6 pounds maximum axial force

**Disengagement Force:** 8 pounds maximum axial force, 1 pound min.

**Contact Retention:** 2.3 pounds min. axial force (captivated contacts)

1 inch-ounce min. torque (uncabled receptacles)

Cable Retention:	Axial Force* (lbs)	Torque (in-oz)
Connectors for RG178	.10	N/A
Connectors for RG316	.20	N/A
Connectors for RG316 DS	.25	N/A

\*Or cable breaking strength whichever is less.

**Durability:** 500 cycles minimum

## ENVIRONMENTAL SPECIFICATIONS

(Meets or Exceeds the Applicable Paragraph of MIL-PRF-39012)

**Temperature Range:** - 65°C to + 165°C

**Thermal Shock:** MIL-STD-202, Method 107, Condition F

**Corrosion:** MIL-STD-202, Method 101, Condition B

**Shock:** MIL-STD-202, Method 213, Condition B

**Vibration:** MIL-STD-202, Method 204, Condition B

**Moisture Resistance:** MIL-STD-202, Method 106

# MCX Non-Magnetic RF Connectors For Flexible Cables

Connectivity for  
Business-Critical Continuity

## Straight Crimp Type Plug - Solder or Crimp Contact - Captivated Contact

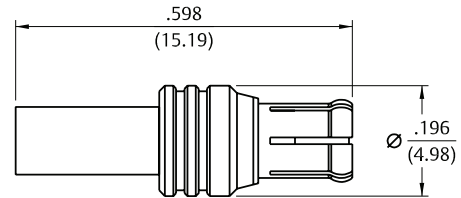

Cable Type	Gold Plated
RG-316/U, 188, 174	133-9403-001
RG-316 DS, 188 DS	133-9404-001

See assembly instructions page 24

## Right Angle Crimp Type Plug - Captivated Contact

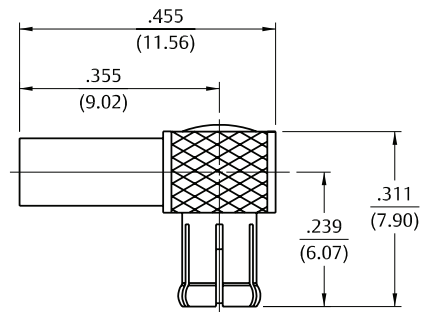

Cable Type	Gold Plated	Silver Plated
RG-316/U, 188, 174	133-9403-101	133-9403-104
RG-316 DS, 188 DS	133-9404-101	
RG-178/U, 196	133-9402-101	

See assembly instructions page 24

## Straight Jack Receptacle

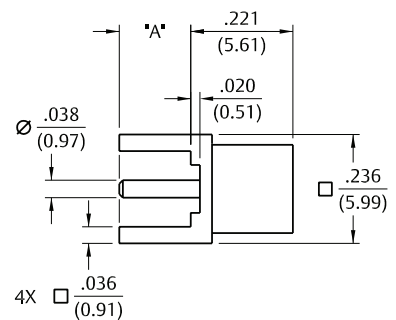

Gold Plated	Silver Plated	"A"
133-9701-201	133-9701-204	.155 (3.94)
133-9701-211		.110 (2.79)

Mounting hole layout figure 4 on page 11

## Straight Jack Receptacle - .100" Layout

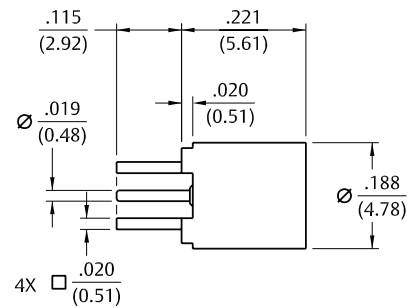

### Gold Plated

133-9701-231

Mounting hole layout figure 3 on page 11 (below)

## Right Angle Jack Receptacle

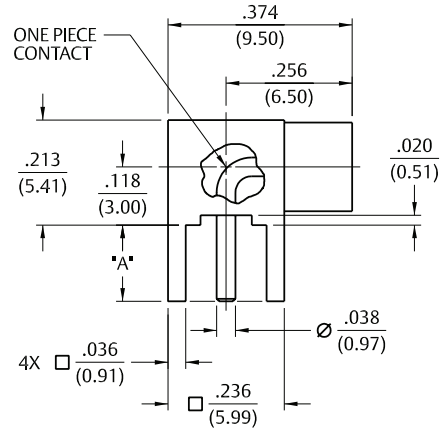

### Gold Plated

### Silver Plated

### "A"

133-9701-301

133-9701-304

.155 (3.94)

133-9701-311

.110 (2.79)

Mounting hole layout figure 4 on page 11 (below)

## End Launch Jack Receptacle - Round Contact

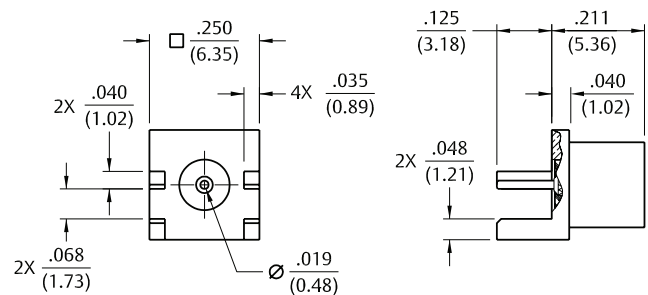

### Gold Plated

### Board Thickness

133-9701-801

.062 (1.57)

## MOUNTING HOLES

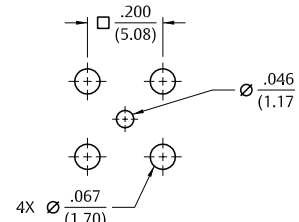
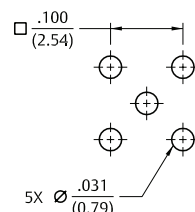

Fig 3

Fig 4

## ELECTRICAL SPECIFICATIONS

**Impedance:** 50 Ohms

**Frequency Range:** Flexible cable connectors ..... 0-12.4 GHz  
Uncabled receptacles ..... 0-18.0 GHz

<b>VSWR:</b> (f = GHz)		Straight	Right Angle
		<u>Cable Connectors</u>	<u>Cable Connectors</u>
RG-316 .....		1.15 + .02f	1.15 + .03f
RG-58 .....		1.15 + .01f	1.15 + .02f
Uncabled receptacles .....			N/A

**Working Voltage:** (VRMS maximum)

<b>Connectors for Cable Type</b>	<u>Sea Level</u>	<u>70K Feet</u>
RG-316 .....	.250	65
RG-58, uncabled receptacles .....	.335	85

**Dielectric Withstanding Voltage:** (VRMS minimum at sea level)

Connectors for RG-316 .....	.750
Connectors for RG-58, uncabled receptacles .....	1000

**Insulation Resistance:** 5000 megohms minimum

**Contact Resistance:** (milliohms maximum)

	<u>Initial</u>	<u>After</u> <u>Environmental</u>
Center contact (straight cabled connectors, uncabled receptacles) .....	.3.0	4.0
Center contact (right angle cabled connectors) .....	.4.0	6.0
Outer contact (all connectors) .....	.2.0	N/A
Braid to body .....	.0.5	N/A

**Corona Level:** (Volts minimum at 70,000 feet)

Connectors for RG-316 .....	.190
Connectors for RG-58, uncabled receptacles .....	.250

**Insertion Loss:** (dB maximum)

Straight flexible cable connectors .....	$.06\sqrt{f(\text{GHz})}$ , tested at 6 GHz
Right angle flexible cable connectors .....	$.015\sqrt{f(\text{GHz})}$ , tested at 6 GHz
Uncabled receptacles .....	N/A

**RF Leakage:** (dB minimum tested at 2.5 GHz)

Flexible cable connectors .....	-60 dB
Uncabled receptacles .....	N/A

**RF High Potential Withstanding Voltage:** (VRMS minimum, tested at 4 and 7 MHz)

Connectors for RG-316 .....	.500
Connectors for RG-58, uncabled receptacles .....	.670

## MECHANICAL SPECIFICATIONS

**Engagement Design:** MIL-STD-348, Series SMA

**Engagement/Disengagement Force:** 2 inch-pounds maximum

**Mating Torque:** 7 to 10 inch-pounds

**Coupling Proof Torque:** 15 inch-pounds minimum

**Coupling Nut Retention:** 60 pounds minimum

**Contact Retention:** 6 lbs. minimum axial force (captivated contacts) 4 inch-ounce minimum torque (uncabled receptacles)

<b>Cable Retention:</b> .....	<u>Axial Force* (lbs)</u>	<u>Torque (in-oz)</u>
Connectors for RG-316 .....	.20	N/A
Connectors for RG-58 .....	.40	N/A

\*Or cable breaking strength whichever is less.

**Durability:** 500 cycles minimum

## ENVIRONMENTAL SPECIFICATIONS

(Meets or Exceeds the Applicable Paragraph of MIL-PRF-39012)

**Temperature Range:** -65°C to +165°C

**Thermal Shock:** MIL-STD-202, Method 107, Condition B

**Corrosion:** MIL-STD-202, Method 101, Condition B

**Shock:** MIL-STD-202, Method 213, Condition I

**Vibration:** MIL-STD-202, Method 204, Condition D

**Moisture Resistance:** MIL-STD-202, Method 106

## Straight Crimp Type Plug (3-piece) - Captivated Contact

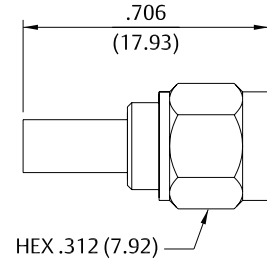

Cable Type	VSWR & Freq. Range	Gold Plated
RG-316/U, 188, 174	1.15 + .02f (GHz) 0-12.4 GHz	142-9403-011
RG-316 DS, 188 DS	1.15 + .02f (GHz) 0-12.4 GHz	142-9404-011
RG-58/U, 141	1.15 + .01f (GHz) 0-12.4 GHz	142-9407-001

See assembly instructions page 25

## Right Angle Crimp Type Plug - Captivated Contact

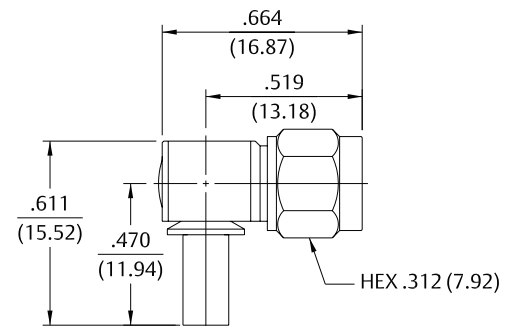

Cable Type	VSWR & Freq. Range	Gold Plated	Silver Plated
RG-316/U, 188, 174	1.15 + .03f (GHz) 0-12.4 GHz	142-9403-101	142-9403-104
RG-316 DS, 188 DS	1.15 + .03f (GHz) 0-12.4 GHz	142-9404-101	
RG-58/U, 141	1.15 + .02f (GHz) 0-12.4 GHz	142-9407-101	142-9407-104

See assembly instructions page 25

## Straight Crimp Type Blukhead Jack (3-piece) - Captivated Contact

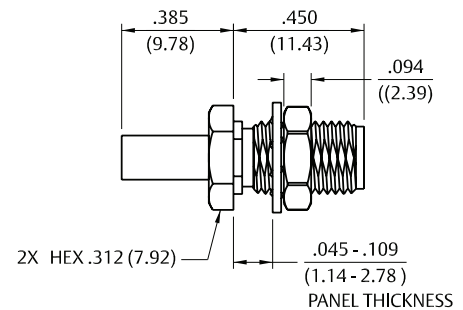

Cable Type	VSWR & Freq. Range	Gold Plated
RG-316/U, 188, 174	1.15 + .02f (GHz) 0-12.4 GHz	142-9303-411

See assembly instructions page 25

Mounting hole layout figure 5 page 15

# SMA Non-Magnetic RF Connectors For PC Mount

Connectivity for  
Business-Critical Continuity

## Straight Jack Receptacle

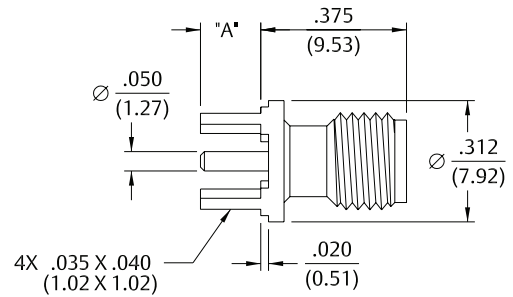

Frequency Range	Gold Plated	"A"
0-18 GHz	142-9701-201	.155 (3.94)
0-18 GHz	142-9701-211	.110 (2.79)

Mounting hole layout figure 6 on page 15

## Straight Plug Receptacle

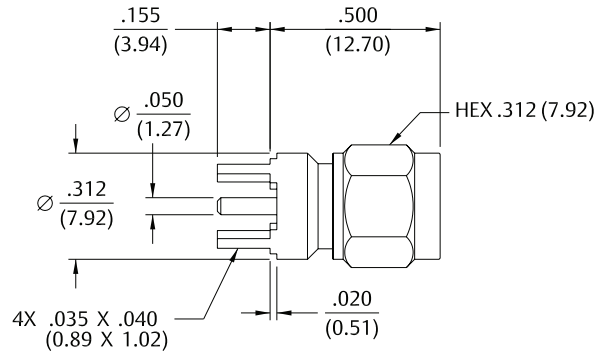

Frequency Range	Gold Plated
0-18 GHz	142-9801-201

Mounting hole layout figure 6 on page 15

## Right Angle Jack Receptacle

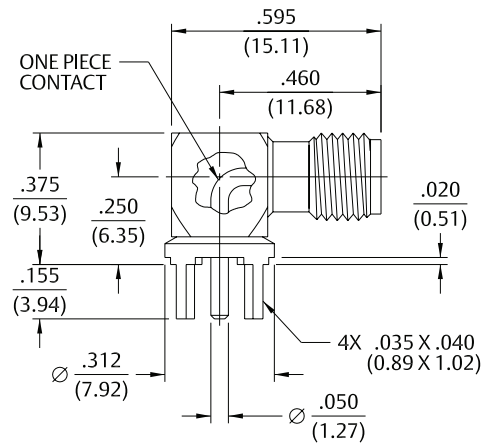

Frequency Range	Gold Plated
0-18 GHz	142-9701-301

Mounting hole layout figure 6 on page 15

## End Launch Jack Receptacle - Round Contact

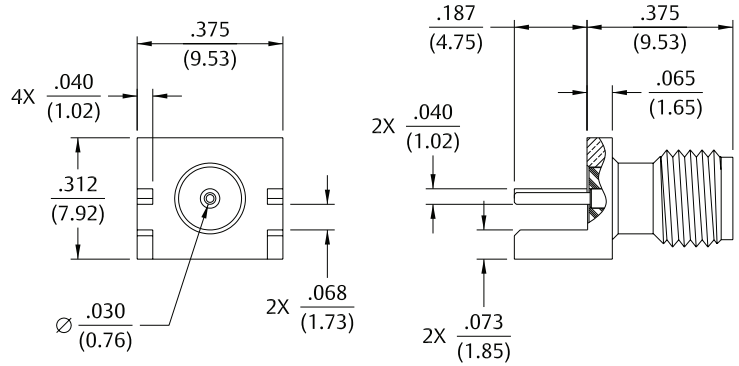

Frequency Range	Gold Plated	Board Thickness
0-10 GHz	142-9701-801	.062 (1.57)

## End Launch Jack Receptacle - Tab Contact

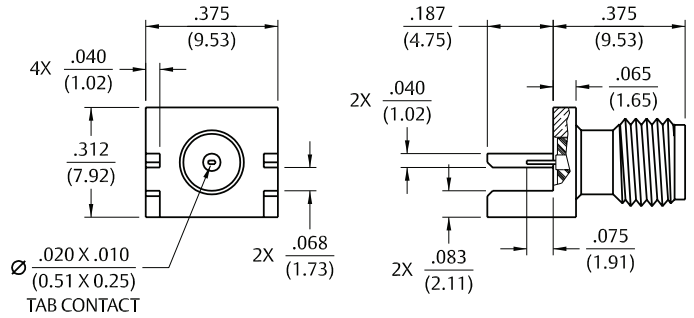

Frequency Range	Gold Plated	Board Thickness
0-10 GHz	142-9701-811	.062 (1.57)

## MOUNTING HOLE

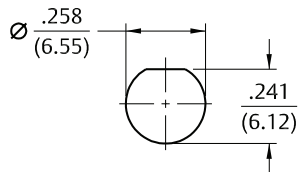

Fig 5

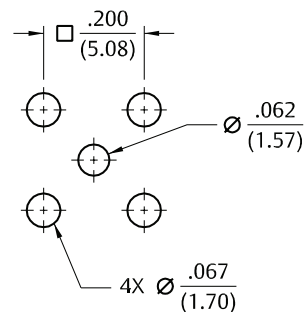

Fig 6

## ELECTRICAL SPECIFICATIONS

**Impedance:** 50 Ohms

**Frequency Range:**

Connectors	0-4 GHz	
<b>VSWR:</b> (f = GHz)	Straight Cable Connectors	Right Angle Cable Connectors
RG-316	1.25 + .04f	1.35 + .04f
Uncabled receptacles	N/A	

**Working Voltage:** (VRMS maximum)

Connectors for Cable Type	<u>Sea Level</u>	<u>70K Feet</u>
RG-316, uncabled connectors	.335	85

**Dielectric Withstanding Voltage:** (VRMS minimum at sea level)

Connectors for RG-316, uncabled receptacles	.1000
---	-------

**Insulation Resistance:** 1000 megohms min

**Contact Resistance:** (milliohms maximum)

	<u>Initial</u>	<u>After Environmental</u>
Center contact (straight cabled connectors and uncabled receptacles)	.6.0	8.0
Center contact (right angle cabled connectors)	.12.0	16.0
Outer contact	.1.0	1.5
Braid to body	.1.0	N/A

**Corona Level:** (Volts minimum at 70,000 feet)

Connectors for RG-316	.250
Uncabled receptacles	.N/A

**Insertion Loss:** (dB maximum, tested at 1.5 GHz)

Straight cable connectors	.0.30 dB
Right angle cable connectors	.0.60 dB
Uncabled receptacles	.N/A

**RF Leakage:** (dB minimum tested at 2.5 GHz)

Cable connectors	.55 dB
Uncabled receptacles	.N/A

**RF High Potential Withstanding Voltage:** (VRMS minimum, tested at 4 and 7 MHz)

Connectors for RG-316	.700
Uncabled receptacles	.600

## MECHANICAL SPECIFICATIONS

**Engagement Design:** MIL-STD-348, Series SMB

**Engagement/Disengagement Force:** 2 pounds min to 14 pounds maximum axial force

**Contact Retention:** 4 lbs. min axial force (captivated contacts)

1 inch-ounce min torque (uncabled receptacles)

<b>Cable Retention:</b>	<u>Axial Force* (lbs)</u>	<u>Torque (in-oz)</u>
Connectors for RG-316	.20	N/A

\*or cable breaking strength whichever is less.

**Durability:** 500 cycles minimum

## ENVIRONMENTAL SPECIFICATIONS

(Meets or Exceeds the Applicable Paragraph of MIL-PRF-39012)

**Temperature Range:** - 65°C to + 165°C

**Thermal Shock:** MIL-STD-202, Method 107, Condition B

**Corrosion:** MIL-STD-202, Method 101, Condition B

**Shock:** MIL-STD-202, Method 213, Condition B



## Straight Crimp Type Plug - Solder or Crimp Captivated Contact

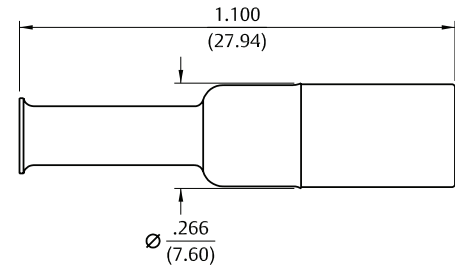

Cable Type	Gold Plated
RG-316/U, 188, 174, 179, 187	131-9403-001
RG-316 DS, 188 DS, 179 DS, 187 DS	131-9404-001

See assembly instructions page 27

## Straight Crimp Type Plug (3-piece) Solder or Crimp Captivated Contact

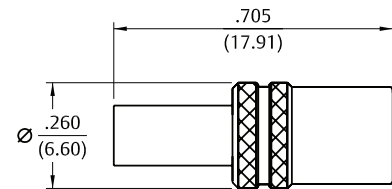

Cable Type	Gold Plated
RG-316/U, 188, 174, 179, 187	131-9403-021
RG-316 DS, 188 DS, 179 DS, 187 DS	131-9404-021

See assembly instructions page 27

## Right Angle Crimp Type Plug - Captivated Contact

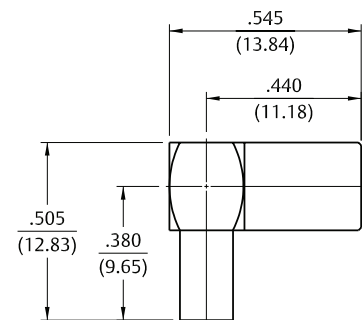

Cable Type	Gold Plated
RG-316/U, 188, 174, 179, 187	131-9403-101
RG-316 DS, 188 DS, 179 DS, 187 DS	131-9404-101

See assembly instructions page 27

# SMB Non-Magnetic RF Connectors For Flexible Cable

Connectivity for  
Business-Critical Continuity

## Straight Jack Receptacle

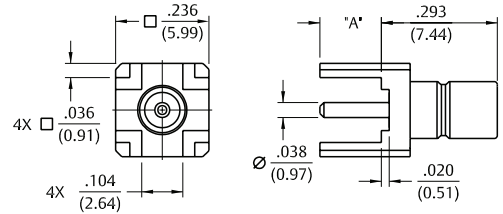

Gold Plated	"A"
131-9701-201	.155 (3.94)
131-9701-211	.095 (2.41)

Mounting hole layout figure 7 on page 18 (below)

## Right Angle Jack Receptacle

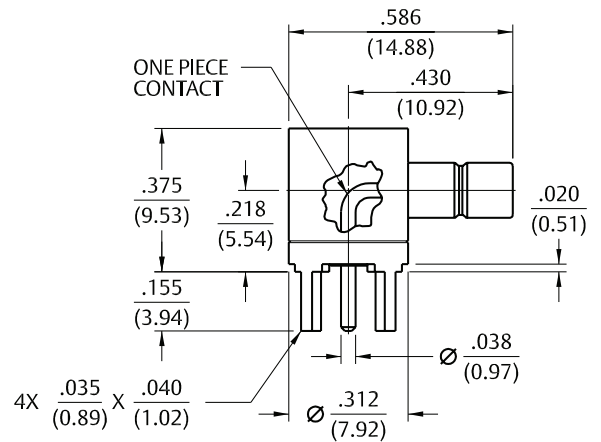

Gold Plated
131-9701-301

Mounting hole layout figure 7 on page 18 (below)

## MOUNTING HOLE

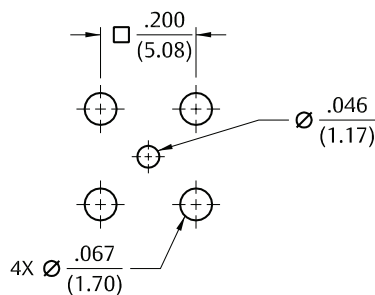

Fig 7

## ELECTRICAL SPECIFICATIONS

**Impedance:** 50 Ohms

**Frequency Range:**  
Flexible Cabled and Receptacles ..... 0-11 GHz

**VSWR:** (f = GHz)  
Straight Flexible Cabled ..... 1.30 Max  
Uncabled Receptacles ..... N/A

**Working Voltage:** (Vrms maximum)

	Sea Level	70K Feet
RG-55/U	335	85
RG-214, LMR-400 Cabled	1000	250
Uncabled Receptacles	1000	250

**Dielectric Withstanding Voltage:** (Vrms minimum)

	Sea Level
RG-55	1000
RG-214, LMR-400 Cabled	2500
Uncabled Receptacles	2500

**Insulation Resistance:** 5000 Megohms minimum

**Contact Resistance:** (milliohms maximum)

	Initial	After Environmental
Center Contact		
Straight Cabled (non-captivated)	1.0	1.5
Straight Cabled (captivated)	2.5	3.0
Uncabled Receptacles	1.0	1.5
Outer Contact	0.2	N/A
Braid to Body	0.05	N/A

**Corona Level:**

	70K Feet
RG-55	250
RG-214, LMR-400	500
Uncabled Receptacles	N/A

**Insertion Loss:** (dB, tested at 9 GHz)

Straight Flexible Cabled	0.15 Max
Right Angle Flexible Cabled	0.30 Max
Uncabled Receptacles	N/A

**RF High Potential Withstanding Voltage:** (Vrms minimum, tested at 4 and 7 MHz)

RG-55 Cabled	670
RG-214, LMR-400 Cabled	1500
Uncabled Receptacles	1500

**RF Leakage:** (dB minimum, tested at 2.5 GHz)

Cabled Connectors	-90
Uncabled Receptacles	N/A

**IMP3:** Typically <-90 dBm  
(tested per IEC Guidelines using 20W inputs swept over 1930-1990 MHz)

## MECHANICAL SPECIFICATIONS

	Axial Force (lbs)	Torque (in-oz)
Cabled Connectors	6	N/A
Uncabled Receptacles	6	4
<b>Cable Retention:</b> (minimum*)	Axial Force (lbs)	Torque (in-oz)
RG-55 Cabled	45	N/A
RG-214, LMR-400 Cabled	90	N/A

\* Or cable breaking strength, whichever is less

## ENVIRONMENTAL SPECIFICATIONS

**Engagement Design:** MIL-STD-348A, Series N

**Durability:** 500 Cycles minimum

**Engagement/Disengagement Force:** 6 inch-pounds maximum

**Mating Torque:** 7 to 10 inch-pounds

**Bulkhead Mounting Nut Torque:** 15 inch-pounds recommended

**Coupling Proof Torque:** 15 inch-pounds minimum

**Coupling Nut Retention:** 100 pounds minimum

**Contact Retention:** (minimum - captivated contacts only)

# Type N Non-Magnetic RF Connectors For Flexible Cable

Connectivity for  
Business-Critical Continuity

## Straight Crimp Type Plug – Solder or Crimp Contact

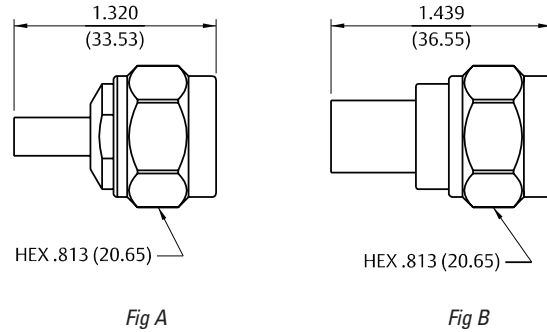

Cable Type	VSWR & Freq. Range	Tri-Alloy Plated	Figure
RG-55/U, 142, 223, 400	1.30 Max, 0-11 GHz	138-9408-007	A
LMR-400, BELDEN 9913	1.30 Max, 0-11 GHz	138-9449-007	B

See assembly instructions page 28

## Right Angle Crimp Type Plug – Captivated Contact

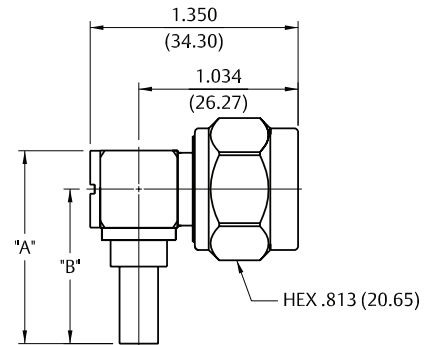

Cable Type	VSWR & Freq. Range	Tri-Alloy Plated	"A"	"B"
RG-55/U, 142, 223, 400	1.35 Max, 0-9 GHz 1.50 Max, 9-11 GHz	138-9408-107	1.253 (31.83)	1.003 (25.48)
RG-9/U, 214	1.35 Max, 0-9 GHz 1.50 Max, 9-11 GHz	138-9418-107	1.365 (34.67)	1.115 (28.32)

See assembly instructions page 28

## Straight Crimp Type Bulkhead Jack – Solder or Crimp Contact

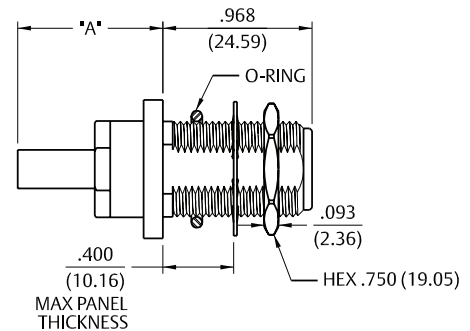

Cable Type	VSWR & Freq. Range	Tri-Alloy Plated	"A"
RG-55/U, 142, 223, 400	1.30 Max, 0-11 GHz	138-9308-407	.943 (23.95)
LMR-400, BELDEN 9913	1.30 Max, 0-11 GHz	138-9349-407	.997 (25.32)

Mounting hole layout figure 8 on page 21  
See assembly instructions page 29

## Rear Mount Bulkhead Jack Receptacle

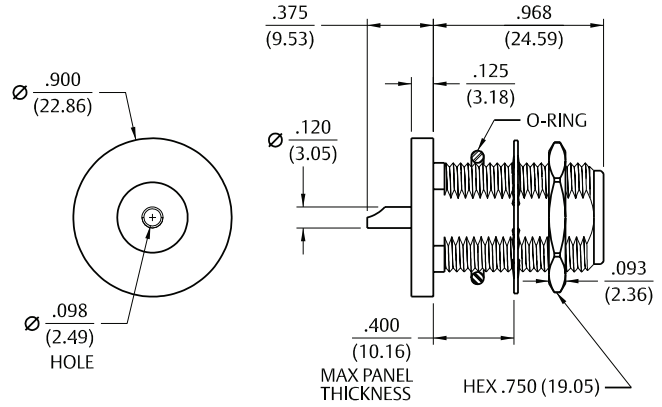

Freq. Range	Tri-Alloy Plated
0-11 GHz	138-9701-407

Mounting hole layout figure 8 on page 21 (below)

## 4-Hole Flange Mount Jack Receptacle – Flush Dielectric

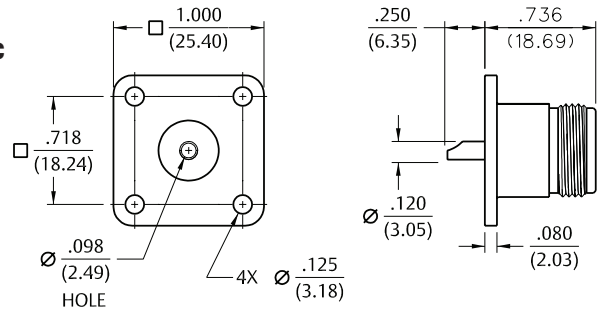

Freq. Range	Tri-Alloy Plated
0-11 GHz	138-9701-607

Mounting hole layout figure 9 on page 21 (below)

## MOUNTING HOLE

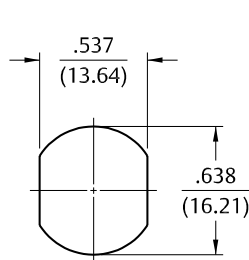

Fig 8

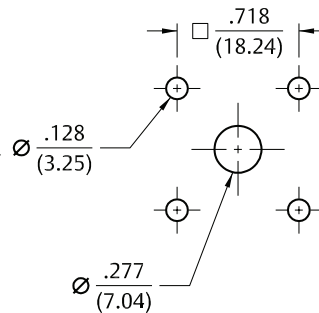

Fig 9

# MMCX Non-Magnetic RF Connectors Assembly Instructions

Connectivity for  
Business-Critical Continuity

## MMCX Straight Plug for RG-316 and RG-316 DS Size Flexible Cable

1. Identify connector parts. (3 piece parts)
2. Strip cable jacket to dimensions shown. Do not nick braid or center conductor during strip operations. Tin center conductor if contact will be solder attached. Do not tin center conductor if contact is to be crimp attached. Slide crimp sleeve onto cable jacket.
3. Assemble contact onto cable as shown.  
**Solder attachment:** Solder contact to center conductor. Care should be taken that excess solder is not applied.  
**Crimp attachment:** Crimp contact to center conductor using Johnson hand tool 140-0000-952 and die set 140-0000-953. Crimp location should be centered between end of contact and cross-hole. Crimp attachment to solid center conductor cables is not recommended.
4. Slide body assembly over contact and under braid, then seat firmly onto contact as shown. The body assembly will “snap” over the contact barb. The cable may have to be held in a soft jawed clamping fixture. Slide crimp sleeve forward and crimp using recommended crimp die hex.

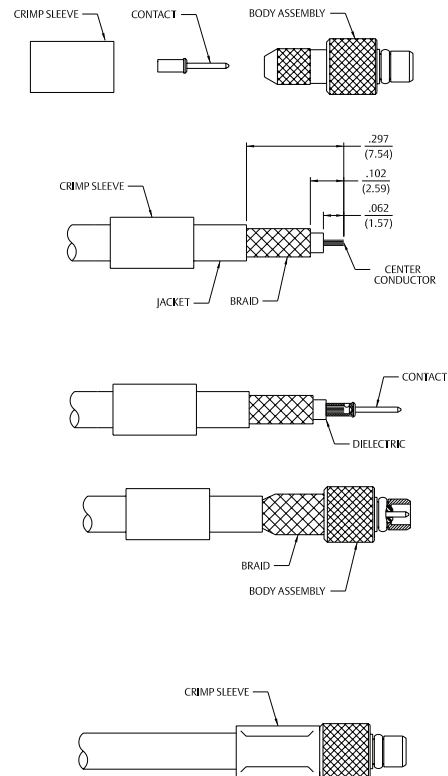

Cable Group	Part No.	Crimp Die Hex
RG-316/u, 188, 174	135-9403-001	.128 (3.25)
RG-316 DS, 188 DS	135-9404-001	.151 (3.83)

## MMCX Straight Plug for .047 (1.19) Diameter and RG-178 Size Flexible Cable

1. Identify piece parts. (3 piece parts)
2. Strip cable jacket to dimensions shown. Do not nick braid or center conductor during strip operations.
3. Slide crimp insert over braid and against jacket, fold braid around crimp insert as shown. Strip dielectric to dimension shown. Tin center conductor if contact is to be soldered attached. Do not tin center conductor if contact is to be crimp attached.
4. Assemble contact assembly onto cable as shown.  
**Solder attachment:** Solder contact to center conductor. Care should be taken that excess solder is not applied.  
**Crimp attachment:** Crimp contact to center conductor using Johnson hand tool 140-0000-952 and die set 140-0000-953. Crimp location should be centered between end of contact and cross-hole. Crimp attachment to solid center conductor cables is not recommended.
5. Slide body assembly over contact and crimp insert, then seat firmly as shown. Crimp body using recommended crimp die hex. Maintain forward pressure on cable while crimping.

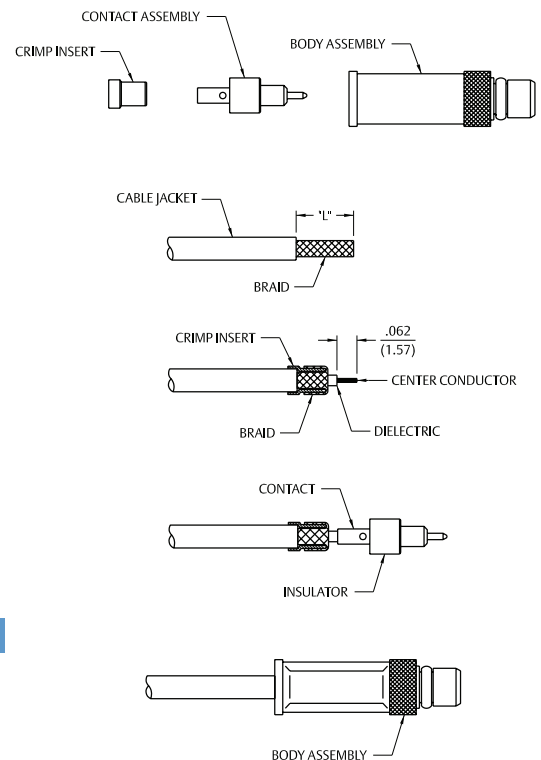

Cable Group	Part No.	"L"	Crimp Die Hex
.047 Flexible	135-9436-001	.135 (3.43)	.105 (2.67) x .250 (6.35) W
RG-178/U, 196	135-9402-001	.184 (4.67)	.105 (2.67) x .250 (6.35) W

## MMCX Right Angle Plug for RG-178 and RG-316 Size Flexible Cable

1. Identify piece parts. (3 piece parts)
2. Strip cable jacket to dimensions shown. Do not nick braid or center conductor during strip operations. Tin center conductor. Slide crimp sleeve onto cable jacket.
3. Flair braid and assemble crimp stem of body subassembly under braid onto cable making certain that the cable center conductor enters contact slot as shown. Arrange braid uniformly around crimp stem. Slide crimp sleeve over braid and crimp securely using recommended crimp hex.
4. Solder center conductor to contact through rear access port. Use a minimum amount of solder for a full fillet joint.
5. Press end cap into body access port using .156 (3.96) diameter flat punch or Johnson assembly tool 141-0000-910.

Cable Group	Part No.	Crimp Die Hex	"A"	"B"	"C"
RG-178, 196	135-9402-111	.105 (2.67)	.310	.100	.035
RG-316/U, 188, 187, 179	135-9403-101	.128 (3.25)	.295	.105	.075

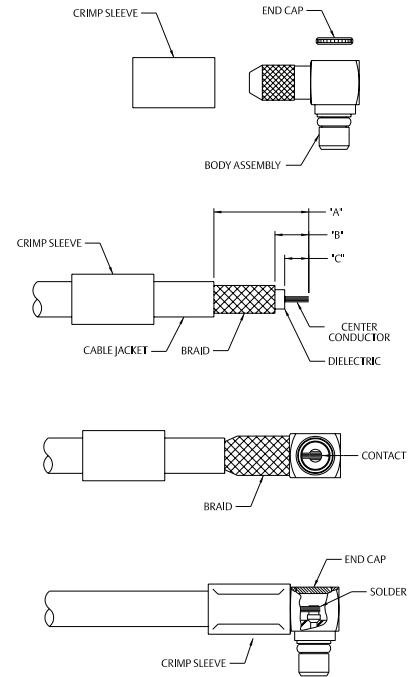

## MMCX Right Angle Plug for .047 (1.20) Diameter Size Flexible Cable with Crimp Insert

1. Identify piece parts. (3 piece parts)
2. Strip cable jacket to dimensions shown. Do not nick braid or center conductor during strip operations.
3. Slide crimp insert over braid and against jacket. Fold braid around crimp insert as shown. Strip cable dielectric to dimension shown. Tin center conductor.
4. Slide body assembly over cable and crimp insert, then seat firmly so cable dielectric butts against contact as shown. Crimp body using recommended crimp hex. Maintain forward pressure on cable while crimping.
5. Solder contact to center conductor through rear access port. Use a minimum amount of solder for a full fillet joint.
6. Press end cap into access port using .156 (3.96) diameter flat punch or Johnson assembly tool 141-0000-910.

Cable Group	Part No.	Crimp Die Hex
.047 Flexible	135-9436-101	.105 (2.67)

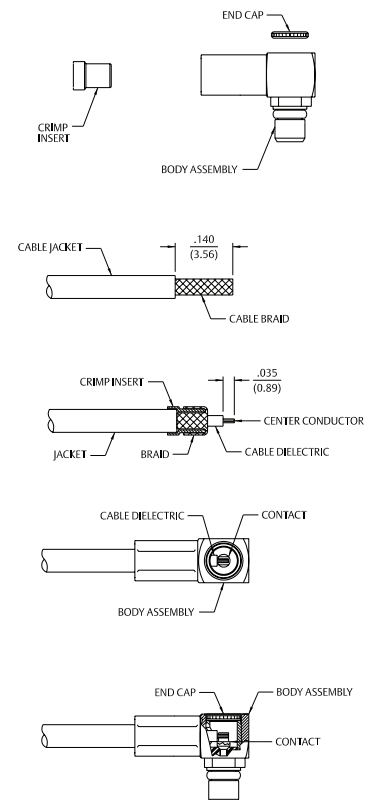

# MCX Non-Magnetic RF Connectors Assembly Instructions

Connectivity for  
Business-Critical Continuity

## MCX Crimp Type Straight Connectors for Flexible Cable

1. Identify connector parts. (3 piece parts)
2. Strip cable to dimensions shown. Do not nick braid or center conductor. Tin center conductor if contact is to be solder attached. Do not tin center conductor if contact is to be crimp attached. Slide heat shrink (as applicable) and crimp sleeve onto jacket of cable.
3. Assemble contact onto cable as shown.  
**Solder attachment.** Solder contact to center conductor through solder hole using .020 (0.51) diameter solder. Use a minimum of solder for a good joint.  
**Crimp attachment.** Crimp contact to center conductor using a miniature 8 indent tool 140-0000-970 with positioner 140-0000-971. Crimp location should be centered between end of contact and cross hole. Crimp attachment to solid center conductor cable is not recommended.
4. Flair braid and slide body assembly over contact and under braid. Then seat body assembly firmly onto contact. (RG-178 is non-captivated, RG-316 incorporates snap-fit captivation.) The cable may have to be held in a clamping fixture. Arrange braid uniformly around crimp stem. Slide crimp sleeve forward and crimp using recommended crimp tool. Slide heat shrink forward and shrink (as applicable).

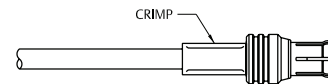
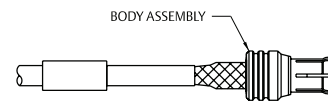
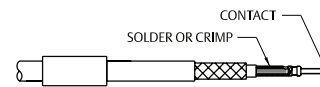
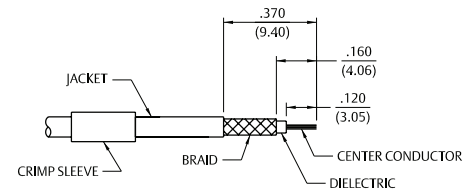
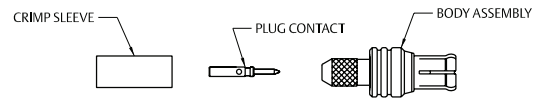

Cable Group	Part No.	Crimp Die Hex
RG-316/U, 188, 174	133-9403-001	.128 (3.25)
RG-316 DS, 188 DS	133-9404-001	.151 (3.83)

## MCX Crimp Type Right Angle Plugs for Flexible Cable

1. Identify connector parts. (4 piece parts).
2. Strip cable to dimensions shown. Do not nick braid or center conductor. A wire stripper of correct size is recommended for this step. Twist stranded center conductor into tight bundle and tin (optional). Slide crimp sleeve onto cable as shown.
3. Flare braid and slide cable into body making certain that the cable dielectric bottoms against center contact. Solder: Solder center conductor to contact through the side access ports and hole in center contact. Use a minimum amount of solder for a full fillet joint. **.015 (0.38) diameter solder is recommended.** Crimp: Crimp Contact Attachment Crimp contact using 41-0000-924 dieset in 144-0000-900 tool frame.
4. Arrange braid uniformly around crimp stem. Slide crimp sleeve over braid and access ports. Crimp securely using recommended hex size and crimp tool.

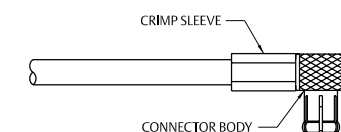
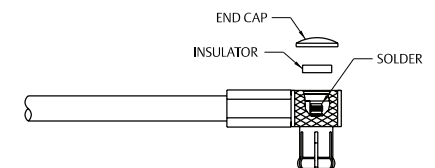
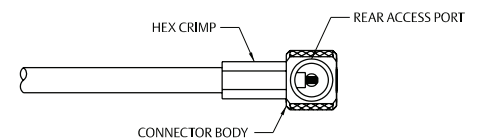
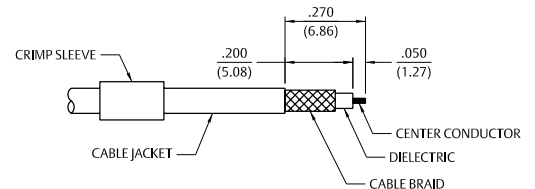
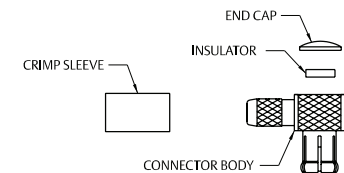

Cable Group	Part No.	Crimp Die Hex
RG-316/U, 188, 174	133-9403-101/104	.128(3.25)
RG-316 DS, 188 DS	133-9404-101	.151(3.83)
RG-178	133-9402-101	.105(2.67)



## SMA Type Straight Plugs For Flexible Cable - Crimp for Solder Contacts

1. Identify connector parts. (3 piece parts—except bulkhead)
2. Strip cable to dimensions shown. Do not nick braid or center conductor. Tin center conductor if contact will be solder attached. Do not tin center conductor if contact is to be crimp attached. A wire stripper of correct size is recommended for this step. Slide heat shrink (as applicable) and crimp sleeve onto jacket of cable.
3. Assemble contact onto cable as shown.  
Solder Attachment: Solder contact to center conductor through solder hole using .020 (0.51) diameter solder. Use a minimum amount of solder for a good joint. Crimp Attachment: Crimp contact to center conductor using Johnson Hand Tool 144-0000-910, setting #2, with positioner 141-0000-907. Crimp location should be centered between end of contact and X-hole. Crimp attachment to solid center conductor cables is not recommended.
4. Flare braid and slide body assembly over contact and under braid. Then seat body assembly firmly onto contact. The cable may have to be held in a clamping fixture. Arrange braid uniformly around crimp stem. Slide crimp sleeve forward and crimp using recommended crimp tool. Slide heat shrink forward and shrink (as applicable).

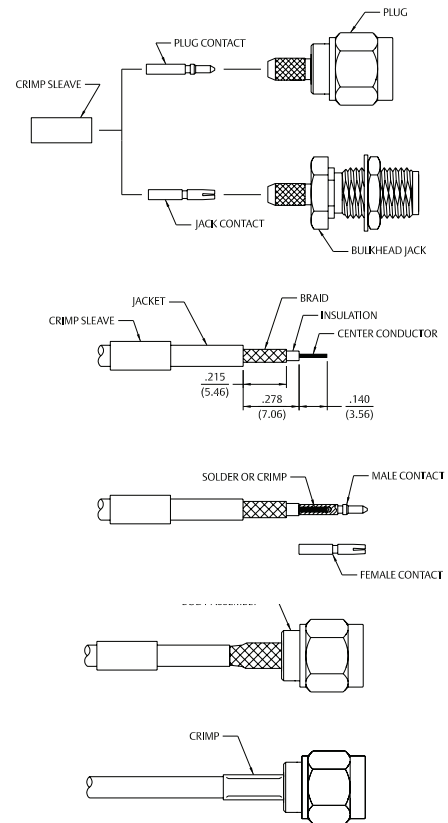

Cable Group	Part No.	Crimp Sleeve Hex Size
RG-316/U, 188, 174	142-9403-011	.128 (3.25)
RG-316 DS, 188 DS	142-9404-011	.151 (3.83)
RG-58/U, 141	142-9407-001	.213 (5.41)

## SMA Crimp Type Right Angle Plugs for Flexible Cable

1. Identify connector parts. (3 piece parts)
2. Strip cable to dimensions shown. Do not nick braid or center conductor. A wire stripper of correct size is recommended for this step. Twist stranded center conductor into tight bundle and tin (optional). Slide crimp sleeve onto cable as shown.
3. Flare braid and slide cable into body making certain that the cable insulation bottoms on center contact. Solder center conductor to contact through the rear access port. Use a minimum amount of solder for a full fillet joint. **.020 (0.51) diameter solder is recommended.**
4. Arrange braid uniformly around crimp stem. Slide crimp sleeve over braid and crimp securely using recommended crimp tool. Place expansion cap in access port and seat with .187 (4.75) diameter flat punch. Shrink heat shrink tubing over crimp sleeve if applicable.

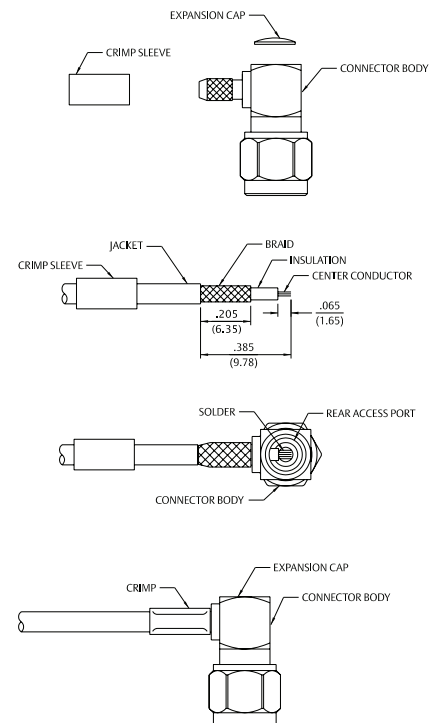

Cable Group	Part No.	Crimp Sleeve Hex Size
RG-316/U, 188, 174	142-9403-101/104	.128 (3.25)
RG-316 DS, 188 DS	142-9404-101	.151 (3.83)
RG-58/U, 141	142-9407-101/104	.213 (5.41)

# SMB Non-Magnetic RF Connectors Assembly Instructions

Connectivity for  
Business-Critical Continuity

## SMB 3-Piece Straight Plugs

1. Identify connector parts. (3 piece parts): Crimp sleeve, body assembly and contact
2. Strip cable to dimensions shown. Do not nick braid or center conductor. Tin center conductor if contact will be solder attached. Do not tin center conductor if contact is to be crimp attached. Slide heat shrink (as applicable) and crimp sleeve onto jacket of cable.
3. Assemble contact onto cable as shown.  
**Solder Attachment:** Solder contact to center conductor through solder hole using .015 (0.38) diameter solder. Use a minimum amount of solder for a good joint.  
**Crimp Attachment:** A miniature 8 indent crimp tool 140-0000-970 is recommended. Crimp location should be centered between end of contact and X-hole using positioner 140-0000-971. Crimp attachment to solid center conductor cables is not recommended.
4. Flare braid and slide body assembly over contact and under braid. Then seat body assembly firmly onto contact. The cable may have to be held in a clamping fixture. Arrange braid uniformly around crimp stem. Slide crimp sleeve forward and crimp using recommended crimp tool. Slide heat shrink forward and shrink (as applicable)..

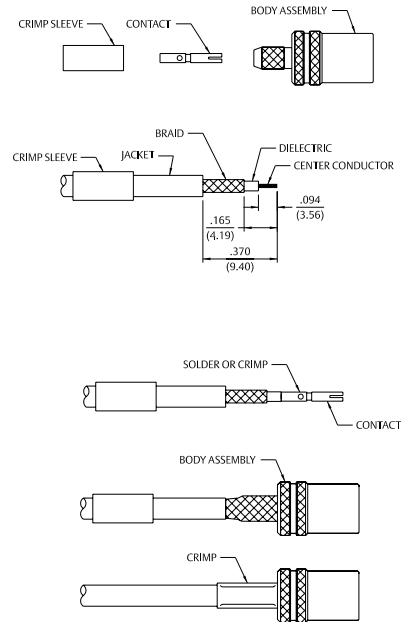

Cable Group	Part No.	Crimp Sleeve Hex Size
RG-316/U, 188, 174, 179, 187	131-9403-021	.128 (3.25)
RG-316 DS, 188 DS, 179 DS, 187 DS	131-9404-021	.151 (3.83)

## SMB Straight Crimp Type Straight Plugs for Flexible Cable

1. Identify connector parts. (2 piece parts)
2. Strip cable to dimensions shown. Do not nick braid or center conductor. A wire stripper of correct size is recommended for this step. Twist stranded center conductor into tight bundle and tin. Slide crimp sleeve onto cable as shown.
3. Flare braid and slide cable into body making certain that the cable dielectric bottoms against center contact.

**Solder Attachment: Solder** center conductor to contact through the side access ports and hole in center contact. Use a minimum amount of solder for a full fillet joint. **.020 (0.51) diameter solder is recommended.**

**Crimp Attachment:** Crimp contacts with 141-0000-911 dieset in 144-0000-900 tool frame.

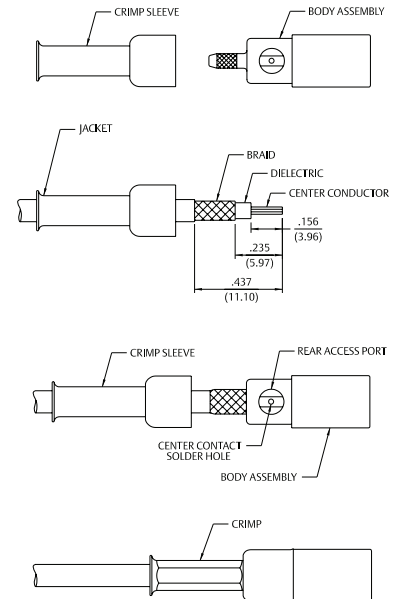

Cable Group	Part No.	Crimp Sleeve Hex Size
RG-316/U, 188, 174, 179, 187	131-9403-001	.128 (3.25)
RG-316 DS, 188 DS, 179 DS, 187 DS	131-9404-001	.151 (3.83)

## SMB Right Angle Crimp Type Straight Plugs for Flexible Cable

1. Identify connector parts. (3 piece parts: crimp sleeve, body assembly and expansion cap.)
2. Strip cable to dimensions shown. Do not nick braid or center conductor. A wire stripper of correct size is recommended for this step. Twist stranded center conductor into tight bundle and tin (optional). Slide crimp sleeve onto cable as shown.
3. Flare braid and slide cable into body assembly making certain that the cable insulation bottoms on center contact. Arrange braid uniformly around crimp stem of body assembly. Slide crimp sleeve over braid and crimp securely using recommended crimp tool.
4. Solder center conductor to contact through the rear and side access ports. Use a minimum amount of solder for a good joint. **.020 (0.51) diameter solder is recommended.** Place expansion cap in access port and seat with a .125 (3.17) diameter flat punch. Snap cover ring over side access port.

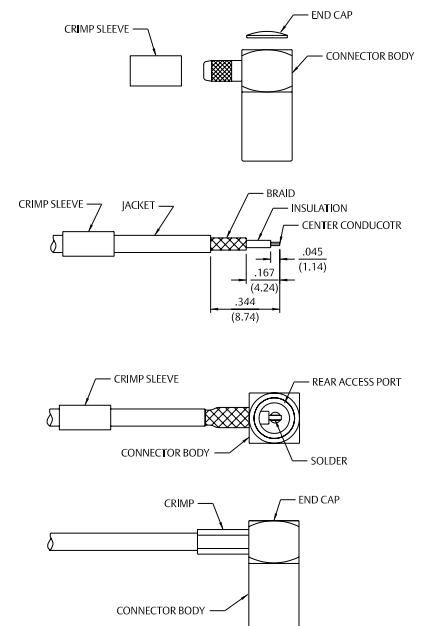

Cable Group	Part No.	Crimp Sleeve HeSize
RG-316/U, 188, 174, 179, 187	131-9403-101	.128 (3.25)
RG-316 DS, 188 DS, 179 DS, 187 DS	131-9404-101	.151 (3.83)

# Type N Non-Magnetic RF Connectors Assembly Instructions

Connectivity for  
Business-Critical Continuity

## Type N Straight Plug Crimp Style for Flexible Cable

1. Identify connector parts (3 piece parts).
2. Strip cable to dimensions shown. Do not nick center conductor. A wire stripper of correct size is recommended for this step. Tin center conductor if contact will be solder attached. Do not tin center conductor if contact will be crimp attached. Slide crimp sleeve onto jacket of cable.
3. Assemble plug contact onto cable as shown. Plug contact should butt against cable dielectric during attachment.

**Solder Attachment:** Solder plug contact to center conductor through solder hole using .020 (0.51) diameter flux core solder wire. Use a minimum amount of solder for a good joint.

**Crimp Attachment:** Crimp plug contact to center conductor using Johnson ergonomic hand crimp frame 140-0000-967 with recommended hex size die set. Crimp location should be on end of plug contact next to cable dielectric. Crimp attachment to solid center conductor cables is not recommended.

4. Flare braid and slide plug connector assembly over plug contact and under braid. Seat plug connector assembly firmly onto contact. Arrange braid uniformly around crimp stem. Slide crimp sleeve forward and crimp using Johnson ergonomic hand crimp frame 140-0000-967 with recommended hex size die set. Maintain forward pressure on cable while crimping.

Cable Group	Part No.	"A"	"B"	Sleeve Hex	Contact Hex
RG-55/U, 142, 223, 400	138-9408-007	.301 (7.65)	.140 (3.56)	.213 (5.41)	.068 (1.73)
LMR-400, BELDEN 9913	138-9449-007	.385 (9.78)	.170 (4.32)	.429 (10.90)	.116 (2.95)

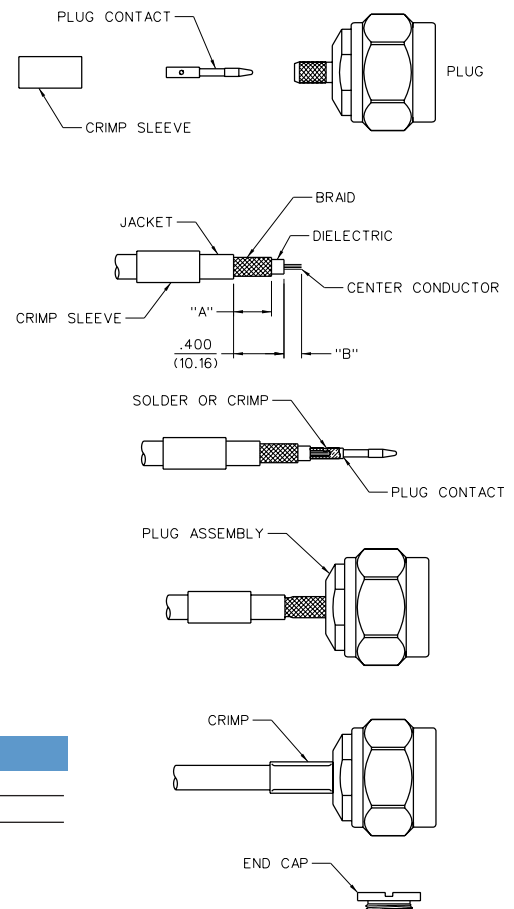

## Type N Right Angle Plug Crimp Style For Flexible Cable

1. Identify connector parts (3 piece parts).
2. Strip cable to dimensions shown. Do not nick center conductor. A wire stripper of correct size is recommended for this step. Twist stranded center conductor into tight bundle and tin (optional). Slide crimp sleeve onto jacket of cable.
3. Flare braid and slide plug connector assembly over cable dielectric and under braid. Make sure cable dielectric bottoms against plug contact as shown for RG-55/U cable group. Maintain a slight gap between Dielectric and Contact for Cable Group RG-9. Solder center conductor to contact through rear access port. Use a minimum amount of solder for a full fillet joint.
4. Arrange braid uniformly around crimp stem. Slide crimp sleeve forward and crimp using Johnson ergonomic hand crimp frame 140-0000-967 with recommended hex size die set. Screw end cap into access port.

Cable Group	Part No.	"A"	"B"	"C"	Crimp Sleeve Hex Size
RG-55/U, 142, 223, 400	138-9408-107	.788 (20.02)	.300 (7.62)	.071 (1.80)	.213 (5.41)
RG-9, 214	138-9418-107	.429 (10.90)	.350 (8.89)	.135 (3.43)	.429 (10.90)

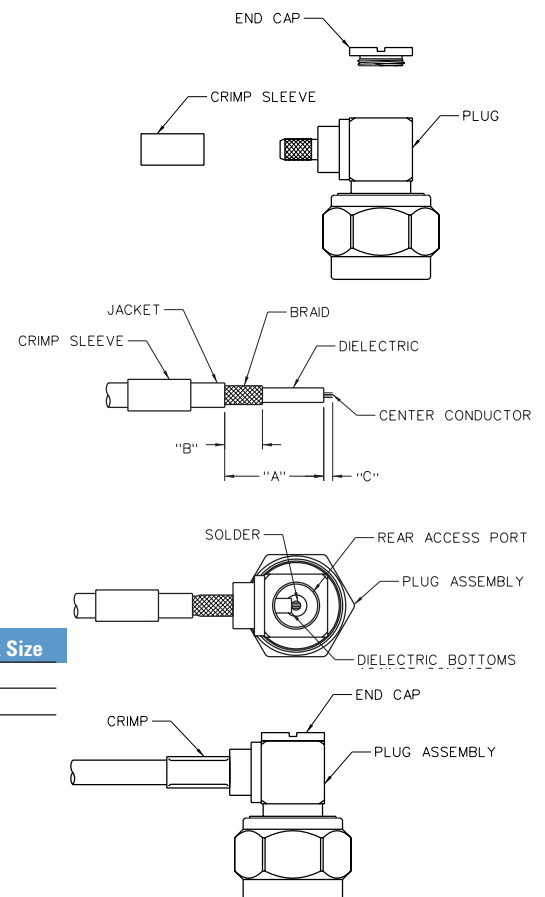

## Type N Bulkhead Jack Crimp Style for 142, and LMR-400 Flexible Cable

1. Identify connector parts (6 piece parts).
2. Strip cable to dimensions shown. Do not nick center conductor. A wire stripper of correct size is recommended for this step. Tin center conductor if contact will be solder attached. Do not tin center conductor if contact will be crimp attached. Slide crimp sleeve onto jacket of cable.
3. Assemble jack contact onto cable as shown. Jack contact should butt against cable dielectric during attachment.
 

**Solder Attachment:** Solder jack contact to center conductor through solder hole using .020 (0.51) diameter flux core solder wire. Use a minimum amount of solder for a good joint.

**Crimp Attachment:** Crimp jack contact to center conductor using Johnson ergonomic hand crimp frame 140-0000-967 with recommended hex size die set. Crimp location should be on end of jack contact next to cable dielectric. Crimp attachment to solid center conductor cables is not recommended.
4. Flare braid and slide bulkhead jack connector assembly over jack contact and under braid. Seat bulkhead jack connector assembly firmly onto contact. Arrange braid uniformly around crimp stem. Slide crimp sleeve forward and crimp using Johnson ergonomic hand crimp frame 140-0000-967 with recommended hex size die set. Maintain forward pressure on cable while crimping.
5. Add gasket, lock washer and mounting nut when installing connector to panel.

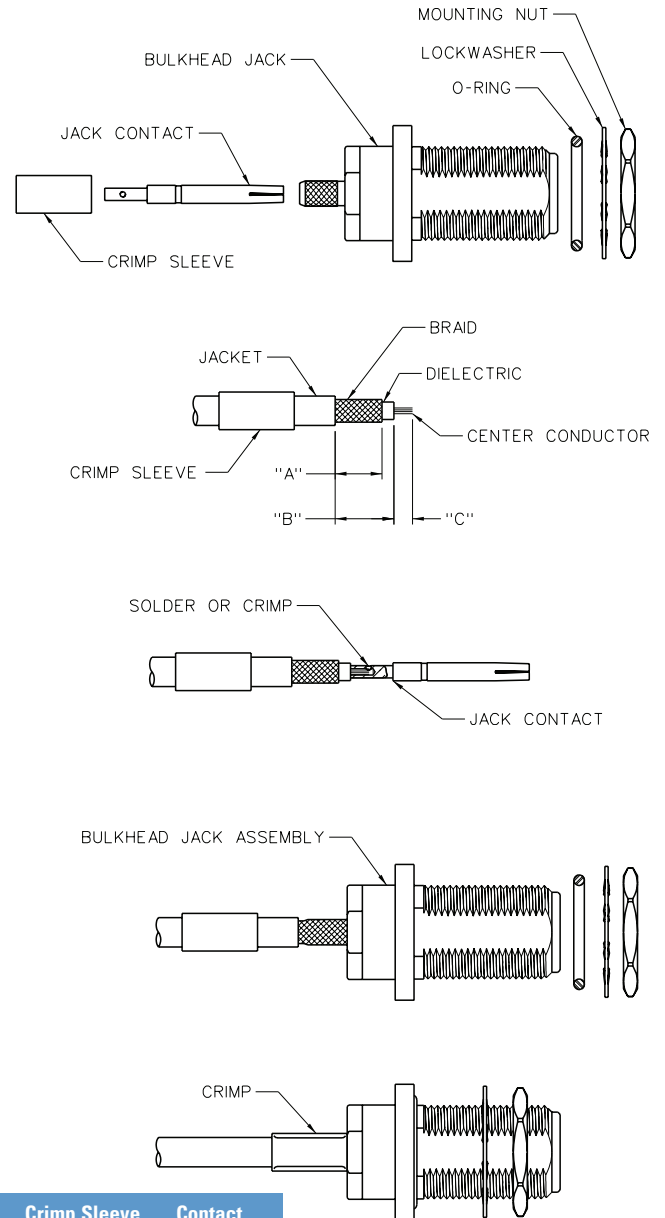

Cable Group	Part No.	"A"	"B"	"C"	Crimp Sleeve Hex Size	Contact Hex Size
RG-55/U, 142, 223, 400	138-9308-407	.310 (7.87)	.389 (9.88)	.135 (3.43)	.213 (5.41)	.068 (1.73)
LMR-400, BELDEN 9913	138-9349-407	.385 (9.78)	.400 (10.16)	.165 (4.19)	.429 (10.90)	.116 (2.95)

Tool	Assembly	
	138-9308-407	138-9349-407
Crimp Frame	140-0000-967	140-0000-967
Die Set	140-0000-990	140-0000-991

## The Johnson Combination - MRI Connectors and Modular Customization

Johnson, a product line of Emerson Network Power Connectivity Solutions, offers the Medical Industry a combination of expertise in Non-Magnetic and Custom Modular Connectivity.

A broad line of Non-Magnetic connector families is available for high density RF signal transmission in the MR Lab environment. MMCX, MCX, SMA, SMB and N Type coaxial Interfaces can be employed to both deliver the power and return multi-coil imaging resolution.

MMCX multi-pack modules can provide .150" (3.81mm) center to center coax arrays that terminate to micro-coaxial cables. Modules can be configured as rails, blocks and cable handles that provide rapid RF coil hookup and change out.

Johnson's vertically integrated production facility guarantees near unity permeability of raw materials, plating and packaging. Non-Magnetic quality is specified in high purity materials and monitored throughout the connector build process.

Emerson Connectivity Solutions continues to work with our customers to develop new solutions as the MR industry transitions to high-end field applications and improved resolution at greater physical depths within the body.

Products are offered through authorized distributors and International sales channels including a direct sales force and a network of manufacturers' representatives. For more information, please call (800) 247-8256.

### About Johnson®

Emerson Network Power Connectivity Solutions, located in Waseca, MN, manufactures Johnson® RF Connectors such as Ultra-miniature (UMC), Micro-miniature (MCX, MCX 75, MMCX and SMP), Sub-miniature (SMA, SMB, SMB Mini-75 Ohm, SMK) and Medium (Type N) in the most popular styles including PC Board Mount, End Launch, Bulkhead Mount and Cable Mounts (Flexible, Semi-rigid and Conformable).



## COMPETITOR CROSS REFERENCE

Emerson P/N	Competitor P/N	Competitor	Emerson P/N	Competitor P/N	Competitor
135-9403-001	908-NM41300	Amphenol	135-9402-111	R110 170 117	Radiall
135-9402-001	908-NM41200	Amphenol	135-9701-201	R110 426 097	Radiall
135-9403-101	908-NM43300	Amphenol	142-9407-001	R125 075 097	Radiall
135-9402-111	908-NM43200	Amphenol	142-9403-101	R125 172 167	Radiall
135-9701-201	908-NM22106	Amphenol	142-9701-201	R125 426 067	Radiall
135-9701-301	908-NM24100	Amphenol	131-9403-021	R114 082 097	Radiall
133-9403-001	919-NM101P-51S	Amphenol	131-9403-101	R114 186 097	Radiall
133-9403-101	919-NM104P-51A	Amphenol			
133-9402-101	919-NM109J-51P	Amphenol			
133-9701-201	919-NM109J-51P	Amphenol			
131-9403-021	903NM285P-51S	Amphenol			
131-9403-101	903-NM289P-51A	Amphenol			
131-9701-201	903-NM415J-51P	Amphenol			

## Emerson Network Power Connectivity Solutions

**Johnson**  
**299 Johnson Avenue**  
**Waseca, MN 56093**  
**USA**

**Tel: 800.247.8256**  
**Fax: 507.833.6287**

**[www.EmersonNetworkPower.com/Connectivity](http://www.EmersonNetworkPower.com/Connectivity)**

## About Emerson Network Power Connectivity Solutions

Emerson Network Power Connectivity Solutions, an Emerson business, serves the needs of wireless communications, telephony and data networks, CATV, security systems, health care and industrial facilities with a full spectrum of broadband copper and fiber optic connectivity products. For more information, visit [www.EmersonNetworkPower.com/Connectivity](http://www.EmersonNetworkPower.com/Connectivity)

## About Emerson

Emerson (NYSE: EMR), based in St. Louis, is a global leader in bringing technology and engineering together to provide innovative solutions to customers through its network power, process management, industrial automation, climate technologies, appliance and tools businesses. For more information, visit [www.Emerson.com](http://www.Emerson.com)

**[www.EmersonNetworkPower.com](http://www.EmersonNetworkPower.com)**

## Emerson Network Power.

The global leader in enabling business-critical continuity.

- AC Power Systems
- Embedded Power
- Outside Plant
- Connectivity
- Inbound Power
- Precision Cooling
- DC Power Systems
- Integrated Cabinet Solutions
- Site Monitoring and Services





Компания «ЭлектроПласт» предлагает заключение долгосрочных отношений при поставках импортных электронных компонентов на взаимовыгодных условиях!

Наши преимущества:

- Оперативные поставки широкого спектра электронных компонентов отечественного и импортного производства напрямую от производителей и с крупнейших мировых складов;
- Поставка более 17-ти миллионов наименований электронных компонентов;
- Поставка сложных, дефицитных, либо снятых с производства позиций;
- Оперативные сроки поставки под заказ (от 5 рабочих дней);
- Экспресс доставка в любую точку России;
- Техническая поддержка проекта, помощь в подборе аналогов, поставка прототипов;
- Система менеджмента качества сертифицирована по Международному стандарту ISO 9001;
- Лицензия ФСБ на осуществление работ с использованием сведений, составляющих государственную тайну;
- Поставка специализированных компонентов (Xilinx, Altera, Analog Devices, Intersil, Interpoint, Microsemi, Aeroflex, Peregrine, Syfer, Eurofarad, Texas Instrument, Miteq, Cobham, E2V, MA-COM, Hittite, Mini-Circuits, General Dynamics и др.);

Помимо этого, одним из направлений компании «ЭлектроПласт» является направление «Источники питания». Мы предлагаем Вам помощь Конструкторского отдела:

- Подбор оптимального решения, техническое обоснование при выборе компонента;
- Подбор аналогов;
- Консультации по применению компонента;
- Поставка образцов и прототипов;
- Техническая поддержка проекта;
- Защита от снятия компонента с производства.



#### Как с нами связаться

**Телефон:** 8 (812) 309 58 32 (многоканальный)

**Факс:** 8 (812) 320-02-42

**Электронная почта:** [org@eplast1.ru](mailto:org@eplast1.ru)

**Адрес:** 198099, г. Санкт-Петербург, ул. Калинина, дом 2, корпус 4, литера А.