

650V, 99mΩ, 33.6 A Super Junction Power MOSFET

Ordering Information

Part Number	Package Option
D3S099N65B-U	TO-220
D3S099N65D-U	TO-247
D3S099N65E-T	TO-263
D3S099N65F-U	TO-220 FullPak

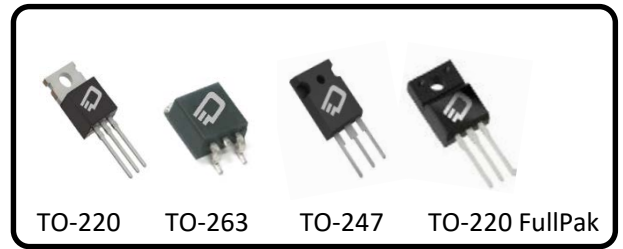

Description

+FET™ is an advanced Super Junction Power MOSFET offering excellent efficiency through low $R_{DS(ON)}$ and low gate charge. +FET™ is a rugged device with precision charge balance implementation designed for demanding uses such as enterprise power computing power supplies, motor control, lighting and other challenging power conversion applications.

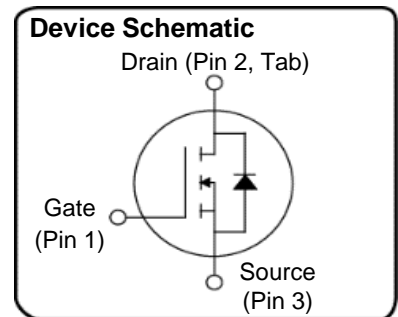

Features

- LOW $R_{DS(ON)}$
- FAST SWITCHING
- HIGH E_{AS}
- REL TEST SPEC: JESD-22
- LOW OUTPUT CAPACITANCE

Benefits

- LOW CONDUCTION LOSSES
- HIGH EFFICIENCY
- EXCELLENT AVALANCHE PERFORMANCE

Table 1 Key Performance Parameters

Parameters	Value	Unit
$V_{DS} @ T_J \text{ max}$	710	V
$R_{DS(on),max}$	<99	mΩ
Q_g, typ	56	nC
$I_D @ 25^\circ\text{C}$	33.6	A
C_{oss}	72	pf

Applications

- POWER FACTOR CORRECTION
- SERVER POWER SUPPLIES
- TELECOM POWER SUPPLIES
- INVERTERS
- MOTOR CONTROL

Table of contents

Description-----	1
Maximum ratings-----	3
Thermal characteristics-----	3
Electrical characteristic-----	4
Electrical characteristics diagrams-----	6
Test Circuit & Waveform-----	11
Revision-----	17

@ $T_J = 25^\circ\text{C}$, unless otherwise specified

Table 2 Maximum ratings

Parameter	Symbol	Values				Unit	Note/Test Condition
		Min.	Typ.	Max			
				220, 263 & 247	220FP		
Continuous drain current(1)	I_D			33.6	15.9	A	$T_C = 25^\circ\text{C}$
				21.3	10.1		$T_C = 100^\circ\text{C}$
Pulsed drain current(2)	$I_{D,pulse}$			135	63.8	A	$T_C = 25^\circ\text{C}$
Avalanche energy, single pulse	E_{AS}			534	534	mJ	$I_D=6.6\text{A}, V_{DD}=50\text{V}$
Avalanche energy, repetitive	E_{AR}			1.34	1.34	mJ	$I_D=6.6\text{A}, V_{DD}=50\text{V}$
Avalanche current, repetitive	I_{AR}			6.6	6.6	A	
MOSFET dv/dt ruggedness	dv/dt			50	50	V/ns	$V_{DS}=\dots 480\text{V}$
Gate source voltage	V_{GS}	-30		30	30	V	static
		-30		30	30		AC (f > 1HZ)
Power dissipation for TO-220	P_{tot}			272	61	W	$T_C = 25^\circ\text{C}$
Operating and storage temperature	T_J, T_{stg}	-55		150	150	$^\circ\text{C}$	
Mounting torque				60		Ncm	M3 and M3.5 screws
					50		M3 screws
Continuous diode forward current	I_S			33.6	15.9	A	$T_C = 25^\circ\text{C}$
Diode pulsed current	$I_{S,pulse}$			135	63.8	A	$T_C = 25^\circ\text{C}$
Reverse diode dv/dt(3)	dv/dt			15	15	V/ns	$V_{DS}=\dots 480\text{V}, I_{SD}<I_D$ $T_J = 25^\circ\text{C}$
Maximum diode commutation speed	dif/dt			500	500	A/us	

Table 3 Thermal characteristics

Parameter	Symbol	Values				Unit	Note/Test Condition
		Min.	Typ.	Max			
				220, 263 & 247	220FP		
Thermal resistance, Junction-case	R_{thJC}			0.5	2.25	$^\circ\text{C}/\text{W}$	
Thermal resistance, Junction-ambient	R_{thJA}			43.4	46	$^\circ\text{C}/\text{W}$	Leaded
Soldering temperature, wavesoldering only allowed at leads	T_{sold}			260	260	$^\circ\text{C}$	1.6mm form case for 10s

Table 4 Static characteristics

Parameter	Symbol	Values			Unit	Note/Test Condition
		Min.	Typ.	Max.		
Drain to source breakdown voltage	$V_{(BR)DSS}$	650			V	$V_{GS}=0V, I_D=1mA$
Gate threshold voltage	$V_{GS(TH)}$	2.3	3.2	4.5	V	$V_{DS}=V_{GS}, I_D=194\mu A$
Zero gate voltage drain current	I_{DSS}			1	uA	$V_{DS}=650V, V_{GS}=0V, T_J = 25^\circ C$
				40		$V_{DS}=650V, V_{GS}=0V, T_J = 150^\circ C$
Gate to source leakage current	I_{GSS}			100	nA	$V_{GS}=\pm 20V, V_{DS}=0V$
Drain-source on-state resistance	$R_{DS(on)}$		94	99	m Ω	$V_{GS}=10V, I_D=16.8A, T_J = 25^\circ C$
			190		m Ω	$V_{GS}=10V, I_D=16.8A, T_J = 150^\circ C$
Gate resistance	R_G		1		Ω	Scaf-F

Table 5 Dynamic characteristics

Parameter	Symbol	Values			Unit	Note/Test Condition
		Min.	Typ.	Max.		
Input capacitance	C_{iss}		2222		pF	$V_{GS}=0V, V_{DS}=100V, f=1MHz$
Output capacitance	C_{oss}		72		pF	
Reverse transfer capacitance	C_{rss}		13		pF	
Effective output capacitance, energy related 1	$C_{o(er)}$		105		pF	$V_{DS}=0\dots 480V, V_{GS}= 0V$
Effective output capacitance, time related 2	$C_{o(tr)}$		331		pF	$I_D=constant, V_{DS}=0\dots 480V, V_{GS}= 0V$
Turn on delay time	$t_{d(on)}$		18		ns	$V_{DD}=400V, I_D=16.8A, R_G=1.0\Omega, V_{GS}=10V$
Rising time	t_r		25		ns	
Turn off delay time	$t_{d(off)}$		41		ns	
Fall time	t_f		22		ns	

Table 6 Gate charge characteristics

Parameter	Symbol	Values			Unit	Note/Test Condition
		Min.	Typ.	Max.		
Total gate charge	Q_g		56		nC	$V_{DD}=480V, V_{GS}=0 \text{ to } 10V, I_D=16.8A$
Gate-source charge	Q_{gs}		14		nC	
Gate-drain charge	Q_{gd}		23		nC	
Gate plateau voltage	$V_{plateau}$		5.0		V	

Table 7 Reverse diode characteristics

Parameter	Symbol	Values			Unit	Note/Test Condition
		Min	Typ	Max		
Diode forward voltage	V_{SD}		0.87	0.96	V	$I_F=33.6A, V_{GS}=0V, T_J = 25^\circ C$
Reverse recovery time	t_{rr}		452		ns	$I_F=33.6A, dI_F/dt=100A/us$
Reverse recovery charge	Q_{rr}		8.0		uC	
Peak reverse recovery current	I_{rrm}		36		A	

Table 8 Thermal Performance

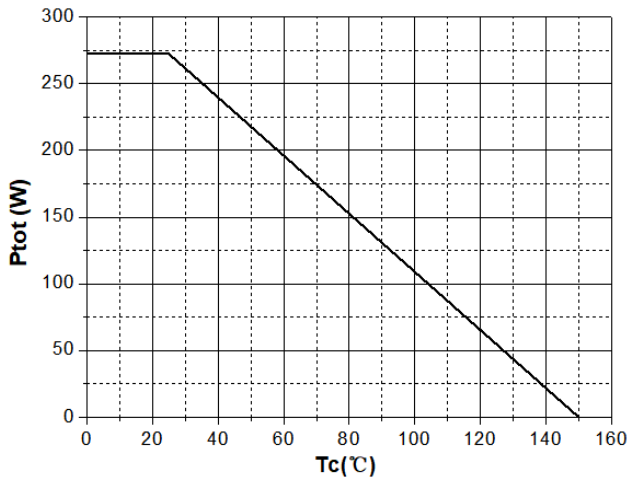
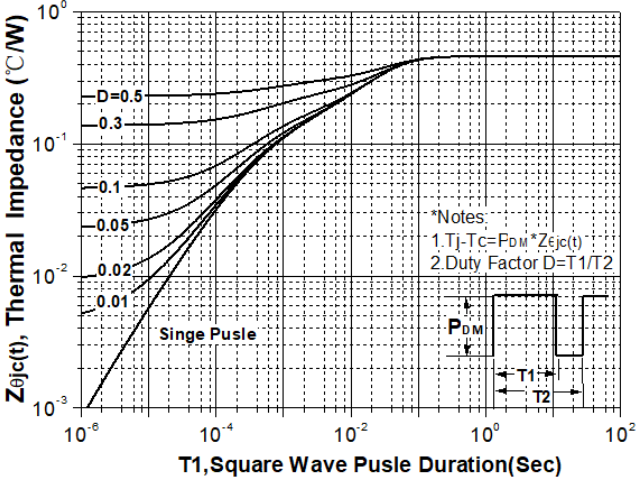
Power dissipation (TO220, TO263 & TO247)	Max. transient thermal impedance (TO220, TO263 & TO247)
	
$P_{tot} = f(T_C)$	$Z_{thJC} = f(t_p); \text{parameter: } D = t_p/T$

Power dissipation (TO220F)	Max. transient thermal impedance (TO220F)
	
$P_{tot} = f(T_C)$	$Z_{thJC} = f(t_p); \text{parameter: } D = t_p/T$

Table 9 Output Characteristics

Table 10 Drain Source Resistance

Table 11 Safe Operating Area

<p>Safe operating area $T_C = 25^\circ\text{C}$ (TO220, TO263 & TO247)</p>	<p>Safe operating area $T_C = 80^\circ\text{C}$ (TO220, TO263 & TO247)</p>
<p>$I_D = f(V_{DS})$; $T_C = 25^\circ\text{C}$; $D=0$; parameter: t_p</p>	<p>$I_D = f(V_{DS})$; $T_C = 80^\circ\text{C}$; $D=0$; parameter: t_p</p>
<p>Safe operating area $T_C = 25^\circ\text{C}$ (TO220F)</p>	<p>Safe operating area $T_C = 80^\circ\text{C}$ (TO220F)</p>
<p>$I_D = f(V_{DS})$; $T_C = 25^\circ\text{C}$; $D=0$; parameter: t_p</p>	<p>$I_D = f(V_{DS})$; $T_C = 80^\circ\text{C}$; $D=0$; parameter: t_p</p>

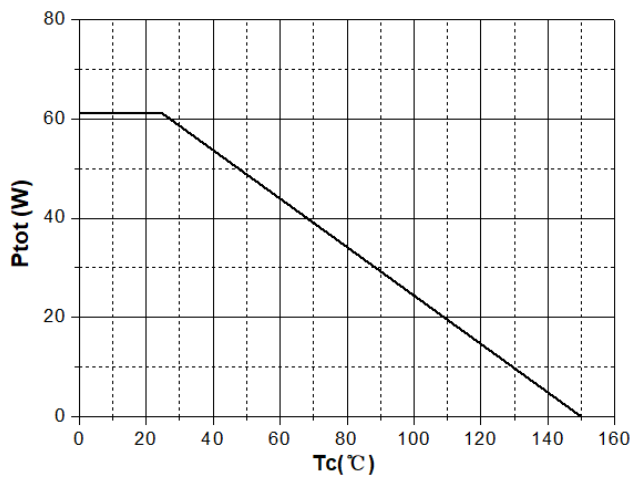
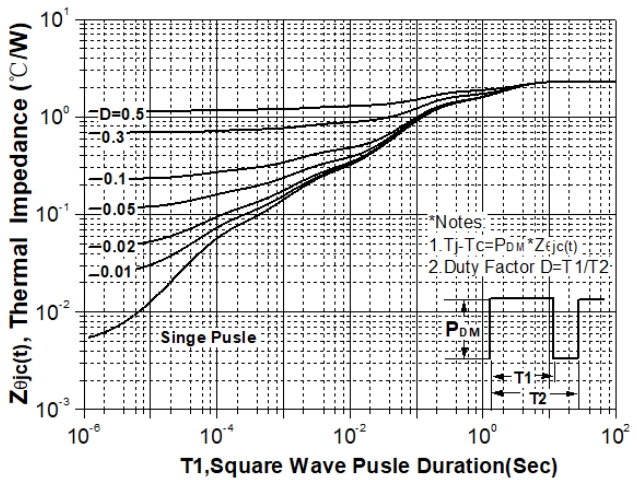
Table 12 Capacitances and Gate Charge

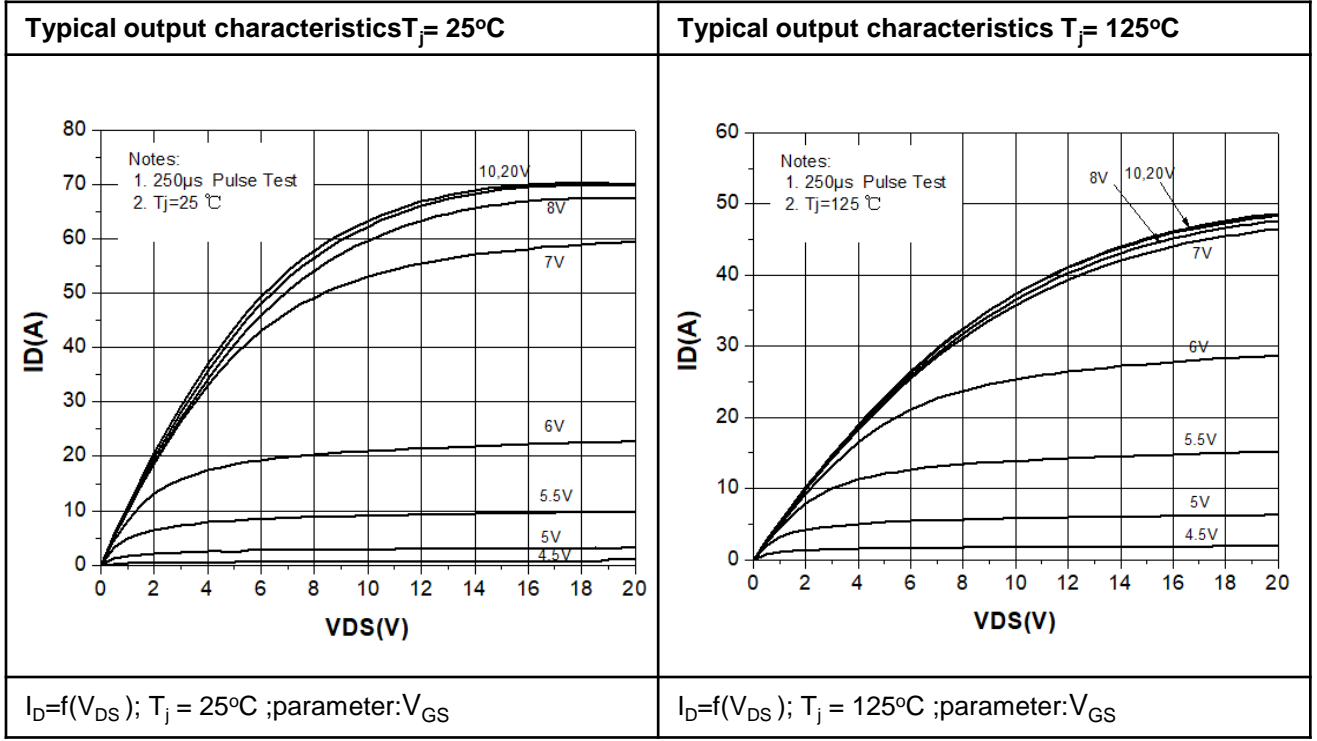
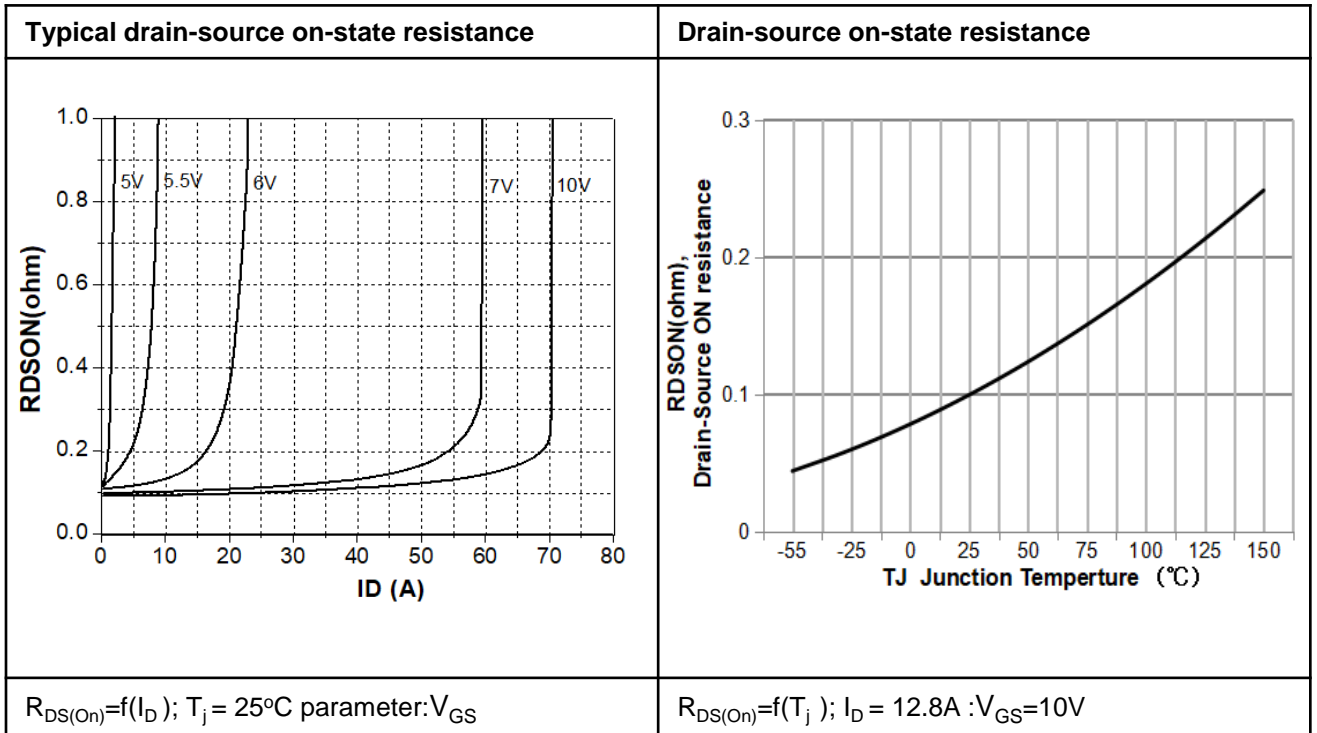
Table 13 Diode Characteristics and Avalanche Energy

Table 14 Breakdown Voltage and Transfer Characteristics

Drain-source breakdown voltage	Transfer Characteristics
 <p>The graph shows the Drain-Source Breakdown Voltage (BV_{DSS}) in Volts (V) on the y-axis (ranging from 600 to 850) versus the TJ Junction Temperature in degrees Celsius (°C) on the x-axis (ranging from -55 to 150). The curve shows a positive correlation, starting at approximately 630V at -55°C and rising to about 815V at 150°C.</p>	 <p>The graph shows the Drain Current (I_D) in Amperes (A) on the y-axis (ranging from 0 to 80) versus the Gate-To-Source Voltage (V_{GS}) in Volts (V) on the x-axis (ranging from 0 to 8). Two curves are shown for different temperatures: 25°C and 150°C. The 25°C curve shows a higher drain current for a given gate voltage compared to the 150°C curve, indicating a decrease in transconductance with increasing temperature.</p>
$V_{BR(DSS)} = f(T_j); I_D = 1\text{mA}$	$I_D = f(V_{GS}); V_{DS} > 2 I_D R_{DS(On)max}; \text{parameter: } T_j$

Table 15 Diode Recovery Characteristic

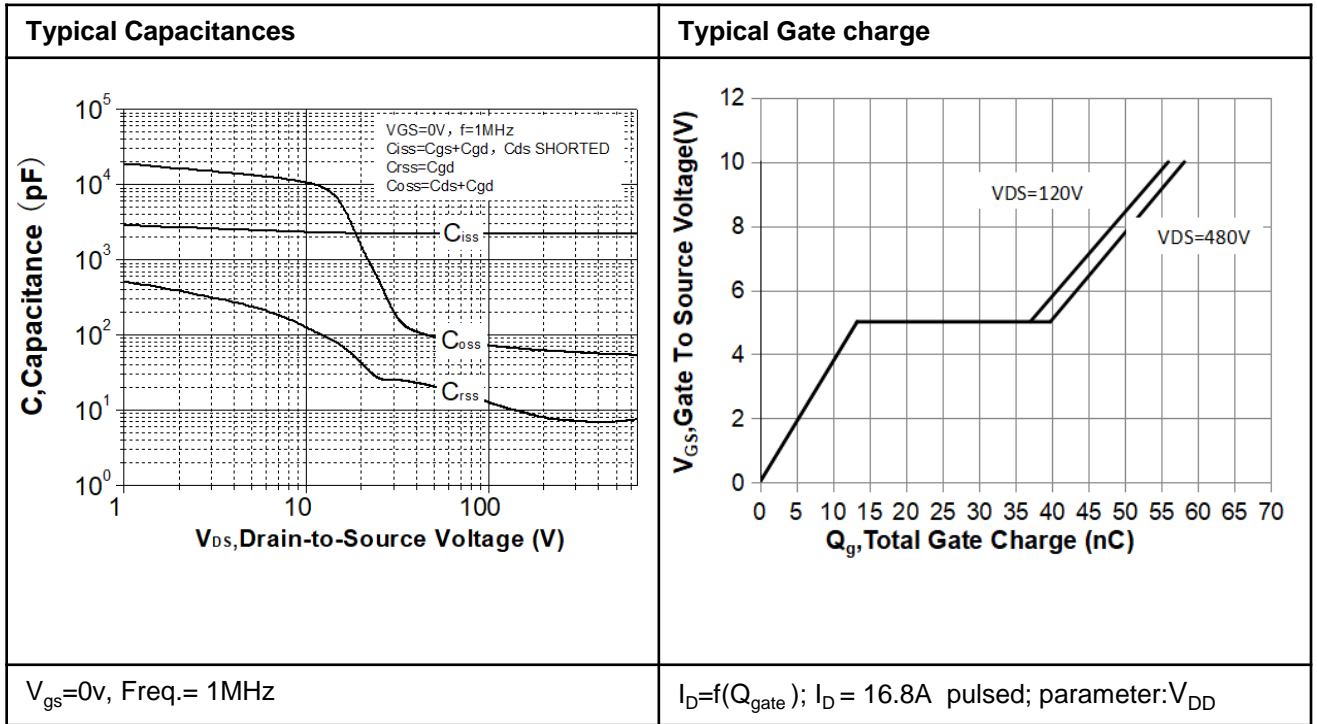
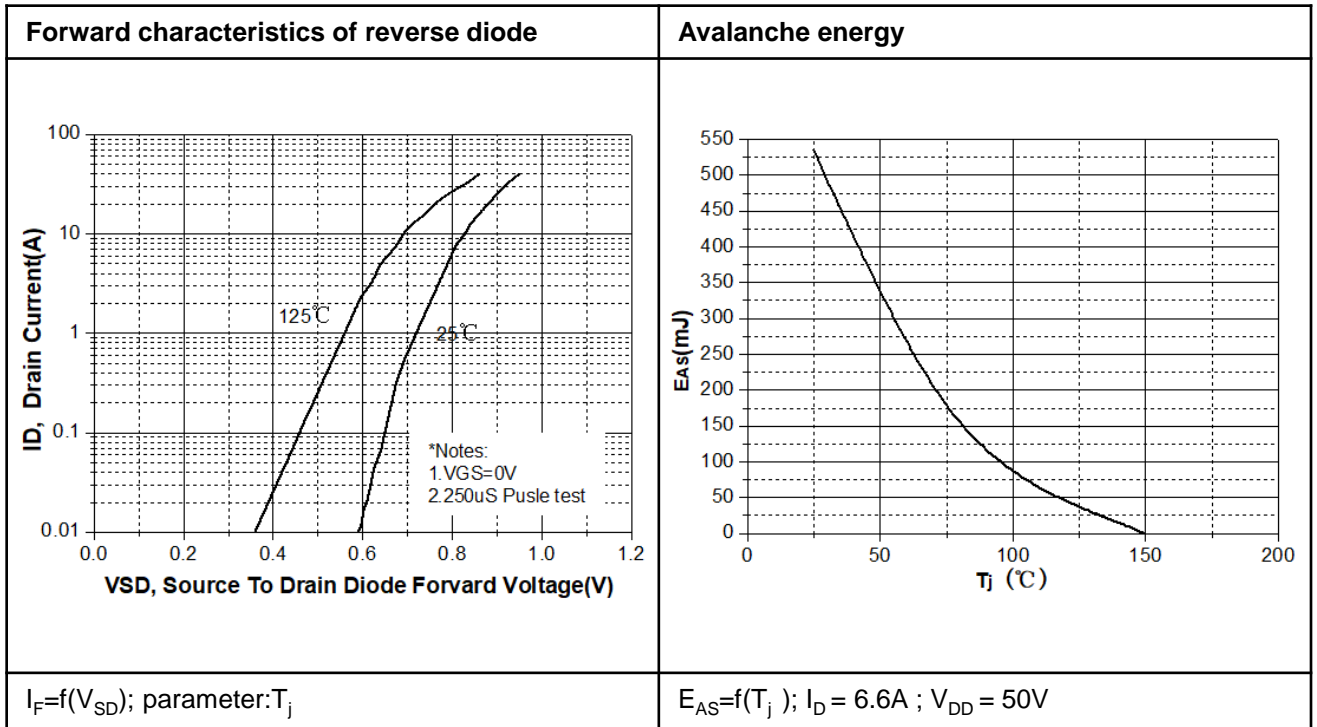
Table 16 Switching Time Characteristic

Table 17 Gate Charge Characteristic

Test Circuit For Gate Charge	Test Waveform For Gate Charge
	

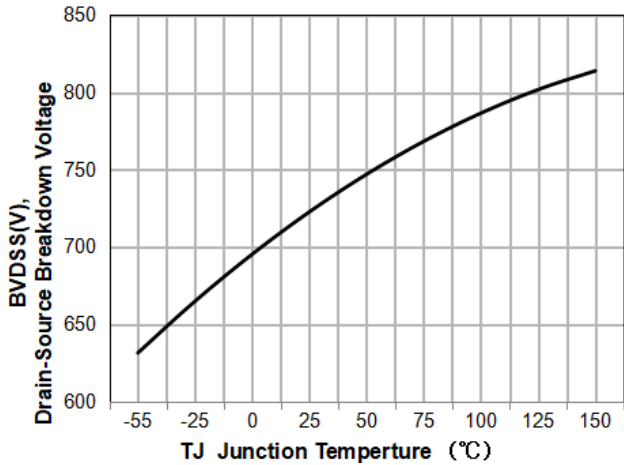
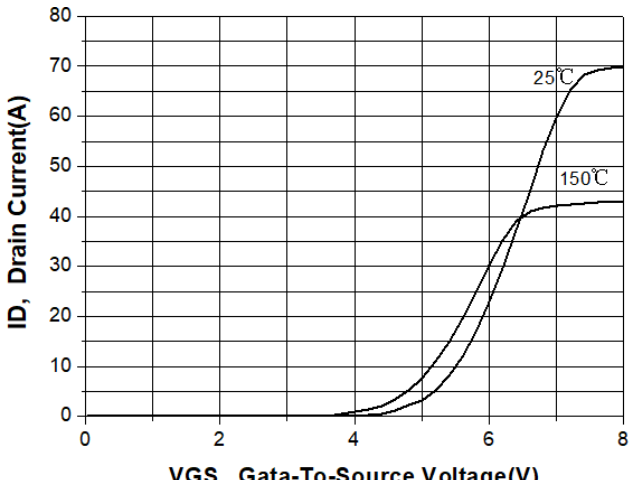
Table 18 Unclamped Inductive Characteristic

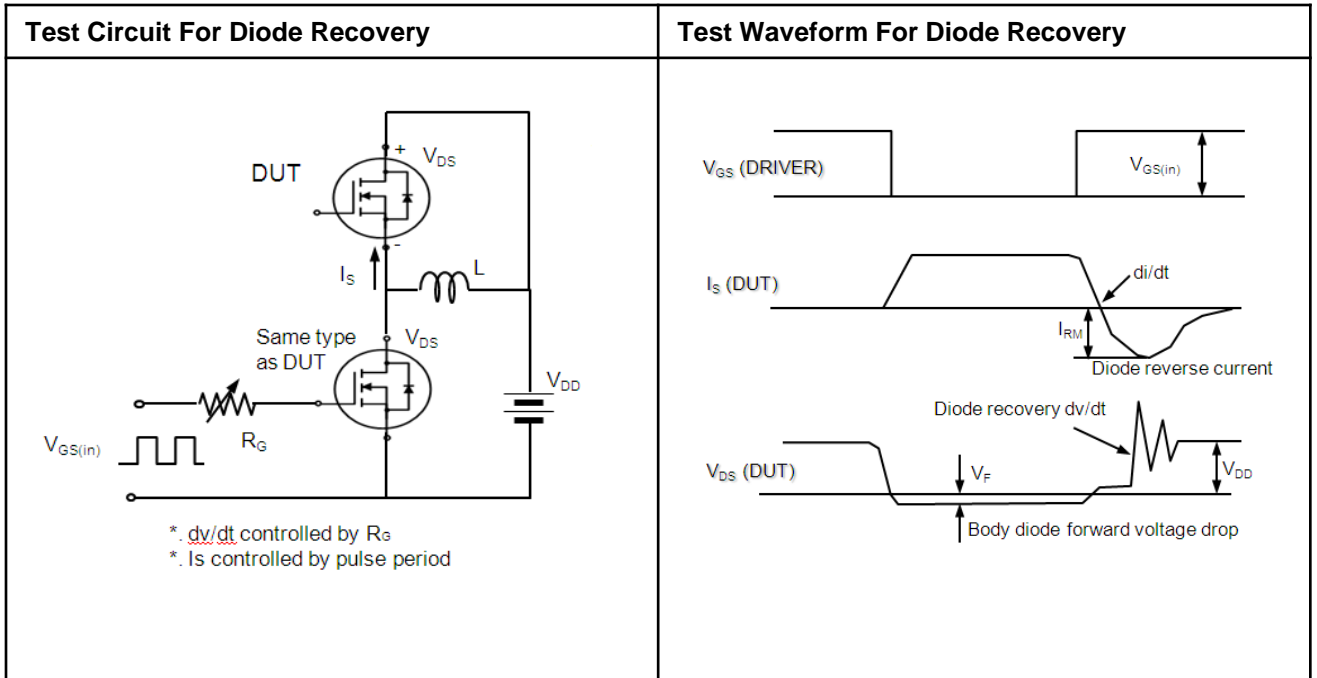
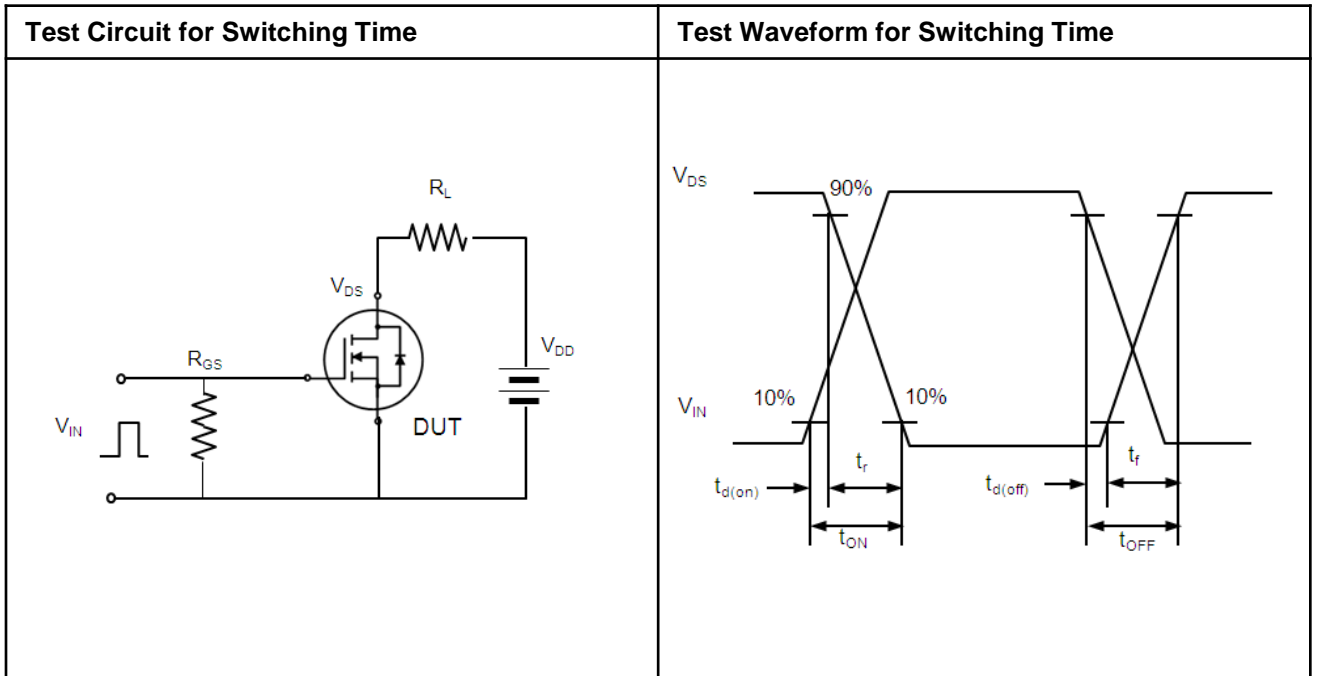
Test Circuit For Unclamped Inductive	Test Waveform For Unclamped Inductive
	 $E_{AS} = \frac{1}{2} L I_{AS}^2$

4a) TO-220

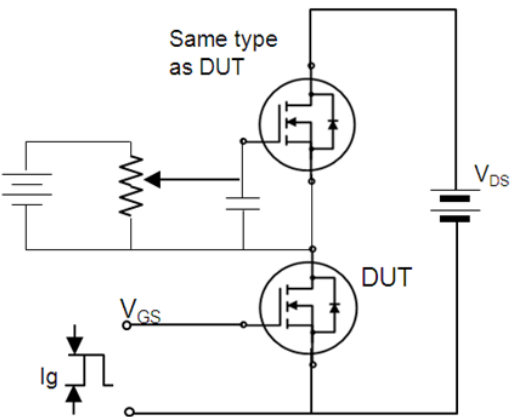
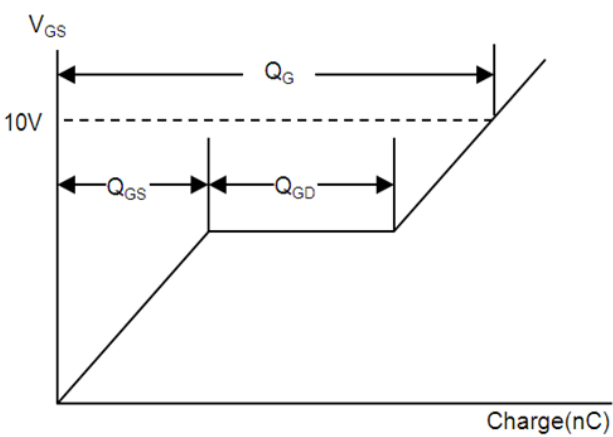
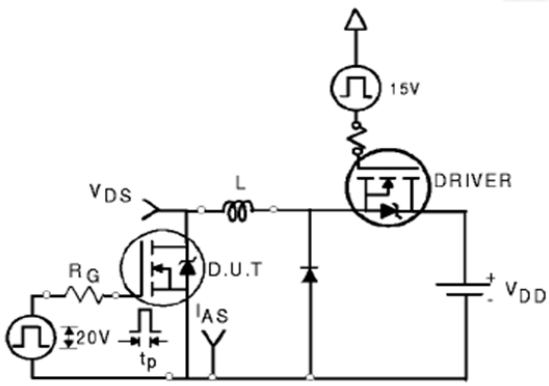
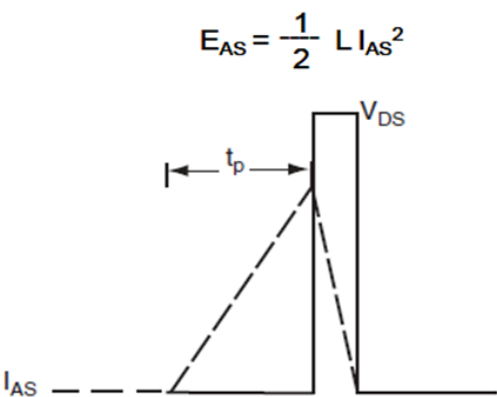
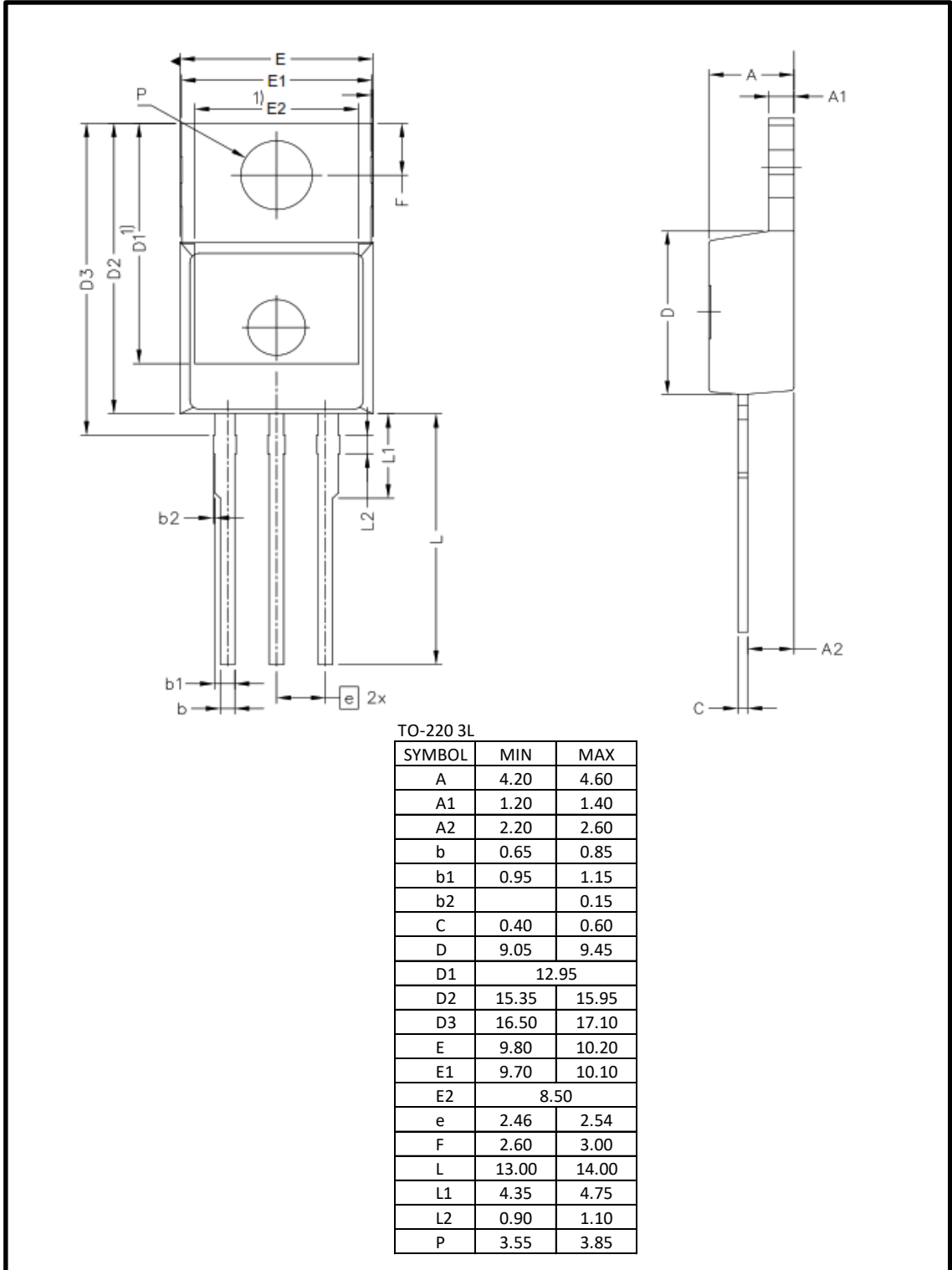

4b) TO-263

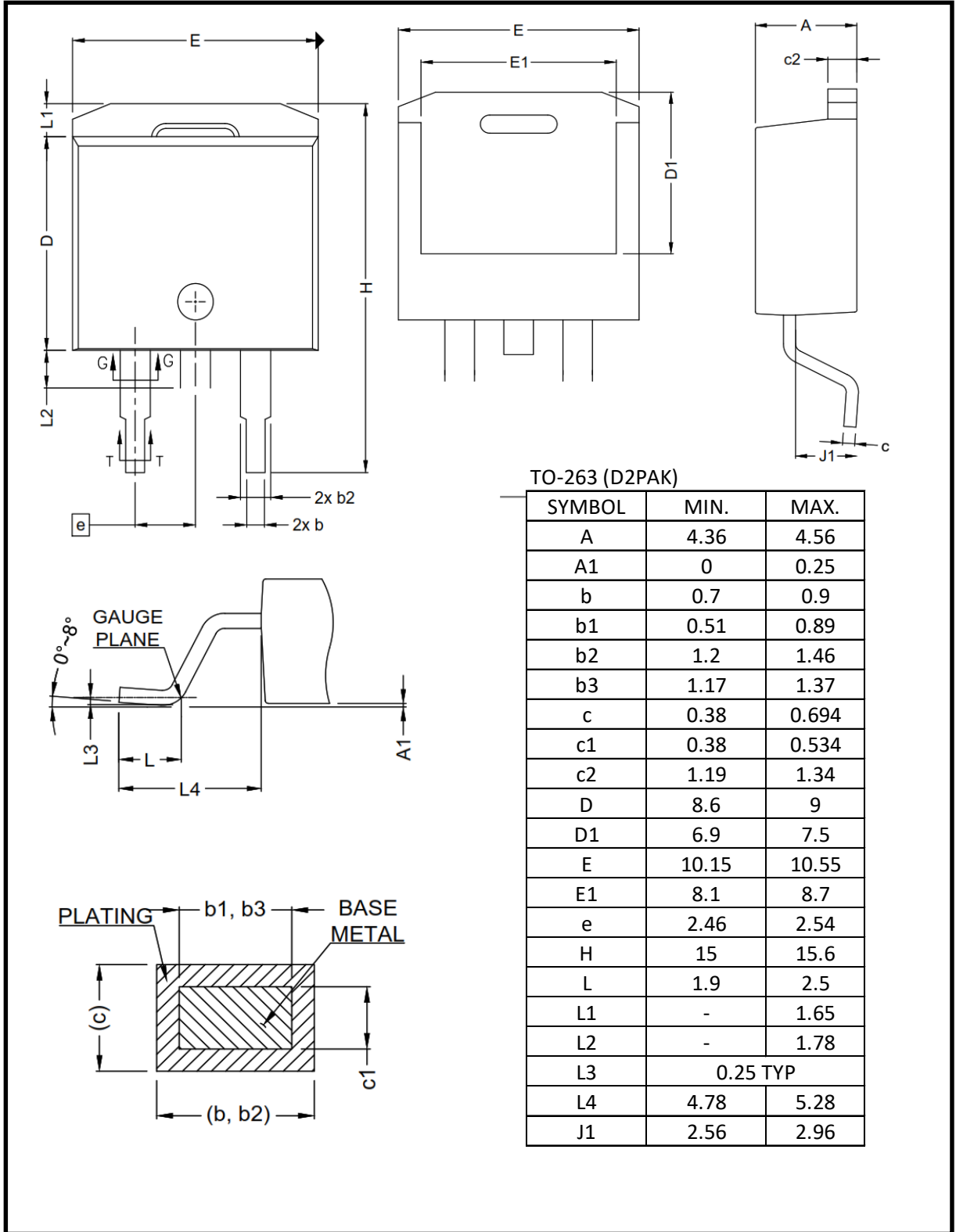

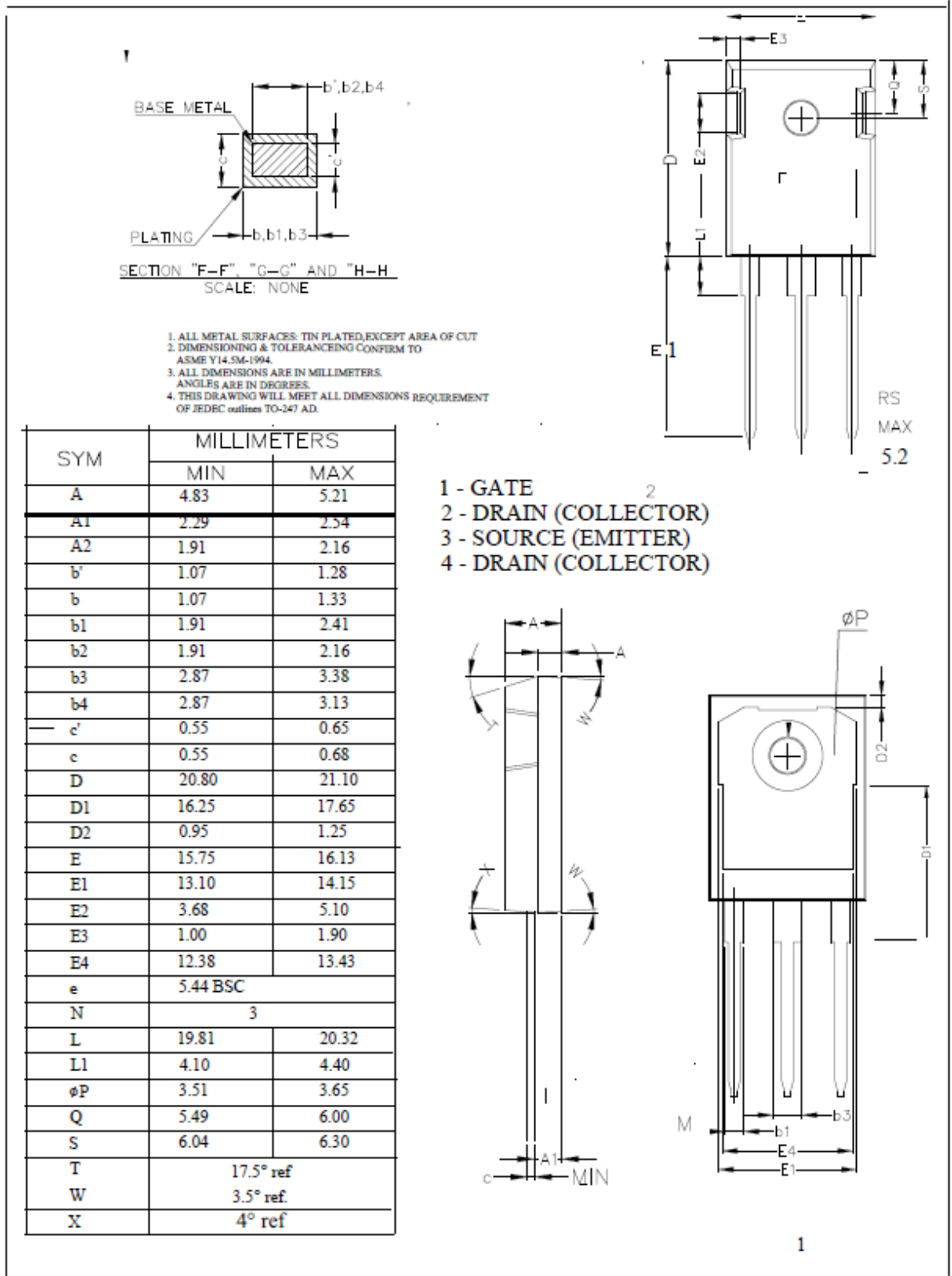
4c) TO-247

4d) TO-220 FullPak

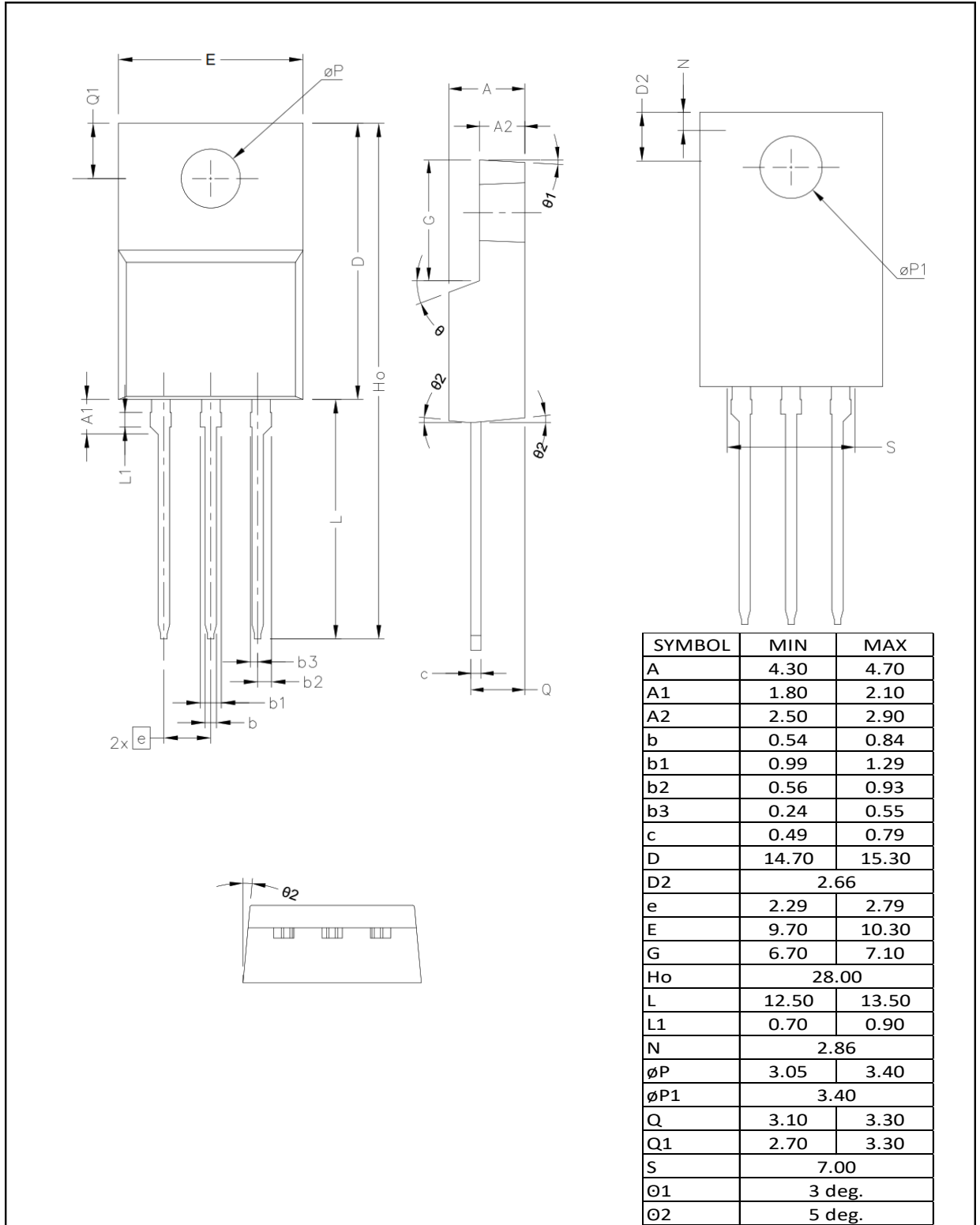

Revision History

Revision	Release Date	Comments
1.0	1-Nov-2016	Preliminary Datasheet Draft
2.0	1-July-2017	Update tables and package detail
2.5	20-Nov-2017	Added TO247 Package
2.6	11-Dec-2017	Added Test Circuits
3.0	2-Jan 2019	Updated/update tables and charts

Resources

www.d3semi.com

Patents, Copyrights and Trademarks

U.S. and Foreign Patents Pending.

The following are trademarks and service marks owned by D3 Semiconductor:

D3 Semiconductor[®], “Flying D” [®], +FET, Defining Precision Power. All Trademarks are property of their respective owners. © D3 Semiconductor 2016. All rights reserved

Legal Disclaimer

The information in this document is provided solely regarding D3 Semiconductor (“D3”) products. The information is not a guarantee of performance or characteristics. D3 Semiconductor reserves the right to modify, change, amend, improve or make corrections to this document, and its products, at any time and its sole discretion without prior written consent or notice. No license to any intellectual property rights is granted or implied under this document. D3 Semiconductor disclaims warranties and liabilities of any kind including non-infringement of intellectual property rights of any third party. D3 Semiconductor products may be used in applications such as automotive, military, aerospace, medical or other applications where failure or malfunction may result in personal injury, death or severe property or environmental damage only with express written approval from D3 Semiconductor. Sale of D3 Semiconductor products are subject to D3 Semiconductor’s standard terms and conditions. Products not purchased through D3 Semiconductor’s authorized distributors, agents or sales representatives are void of warranty.



Компания «ЭлектроПласт» предлагает заключение долгосрочных отношений при поставках импортных электронных компонентов на взаимовыгодных условиях!

Наши преимущества:

- Оперативные поставки широкого спектра электронных компонентов отечественного и импортного производства напрямую от производителей и с крупнейших мировых складов;
- Поставка более 17-ти миллионов наименований электронных компонентов;
- Поставка сложных, дефицитных, либо снятых с производства позиций;
- Оперативные сроки поставки под заказ (от 5 рабочих дней);
- Экспресс доставка в любую точку России;
- Техническая поддержка проекта, помощь в подборе аналогов, поставка прототипов;
- Система менеджмента качества сертифицирована по Международному стандарту ISO 9001;
- Лицензия ФСБ на осуществление работ с использованием сведений, составляющих государственную тайну;
- Поставка специализированных компонентов (Xilinx, Altera, Analog Devices, Intersil, Interpoint, Microsemi, Aeroflex, Peregrine, Syfer, Eurofarad, Texas Instrument, Miteq, Cobham, E2V, MA-COM, Hittite, Mini-Circuits, General Dynamics и др.);

Помимо этого, одним из направлений компании «ЭлектроПласт» является направление «Источники питания». Мы предлагаем Вам помощь Конструкторского отдела:

- Подбор оптимального решения, техническое обоснование при выборе компонента;
- Подбор аналогов;
- Консультации по применению компонента;
- Поставка образцов и прототипов;
- Техническая поддержка проекта;
- Защита от снятия компонента с производства.



Как с нами связаться

Телефон: 8 (812) 309 58 32 (многоканальный)

Факс: 8 (812) 320-02-42

Электронная почта: org@eplast1.ru

Адрес: 198099, г. Санкт-Петербург, ул. Калинина, дом 2, корпус 4, литера А.