

# Customer Information Sheet

DRAWING No.: G125-MHXXX05LIP

IF IN DOUBT - ASK

©

NOT TO SCALE

THIRD ANGLE PROJECTION

ALL DIMENSIONS IN mm

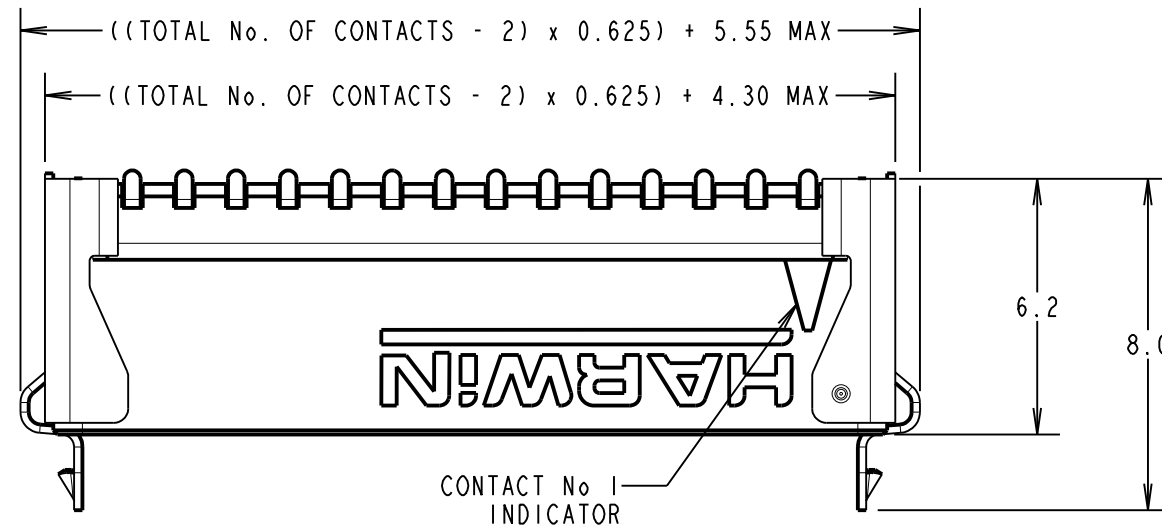
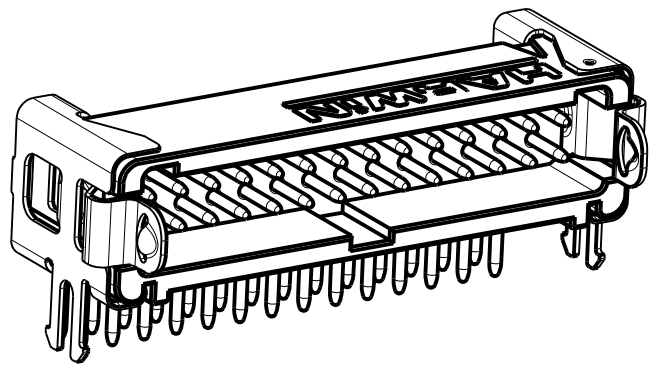

ORDER CODE:

**G125-MHXXX05LIP**

3.3mm PC-TAILS = H1  
4.8mm PC-TAILS = H2

TOTAL No. OF CONTACTS  
06, 10, 12, 16, 20,  
26, 34, 50.

LATCHES:  
1.7mm PCB HOLD DOWN & LATCHES = LI

CONTACT STYLE	DIM 'Z'
H1	3.3±0.15
H2	4.8±0.15

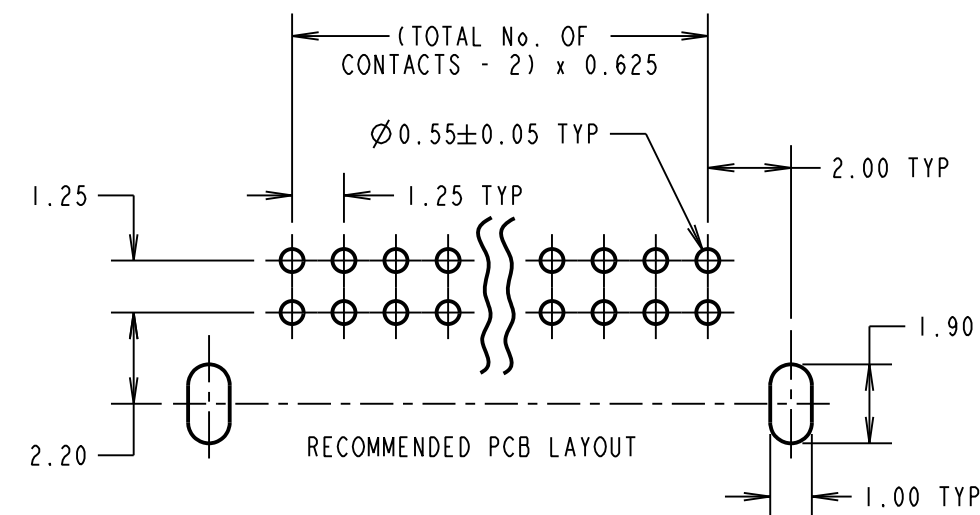
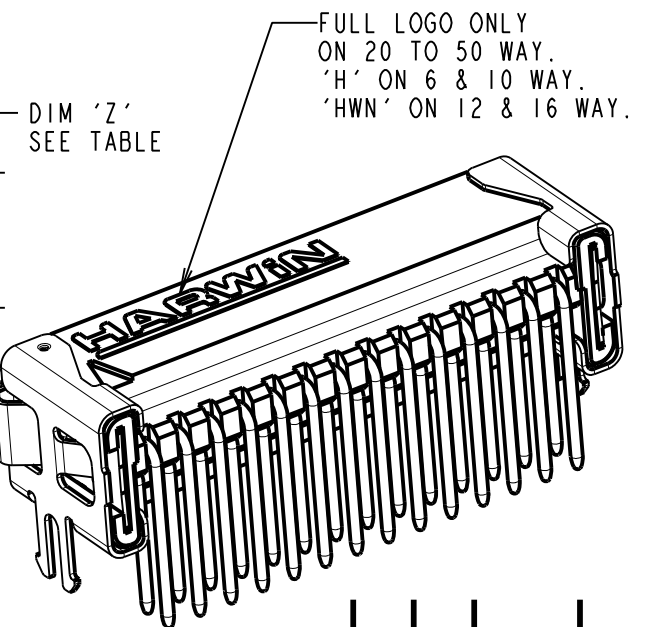
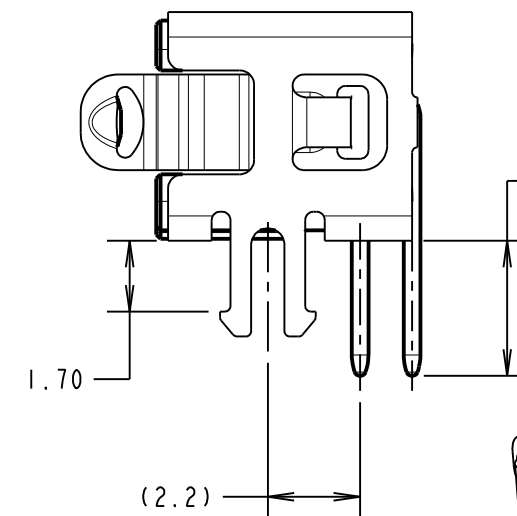
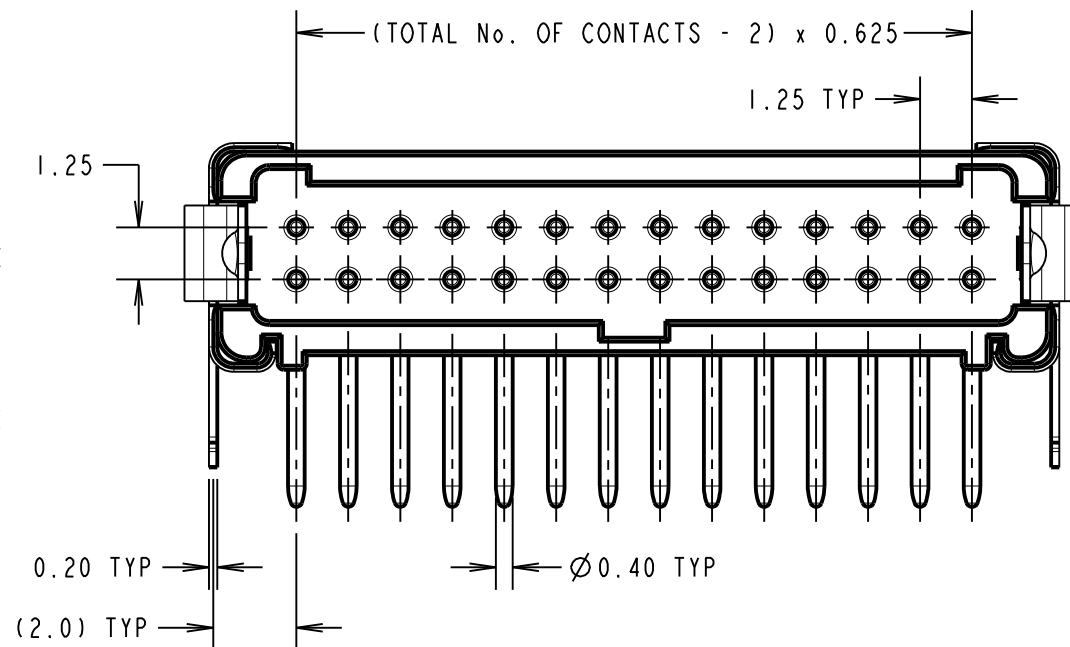
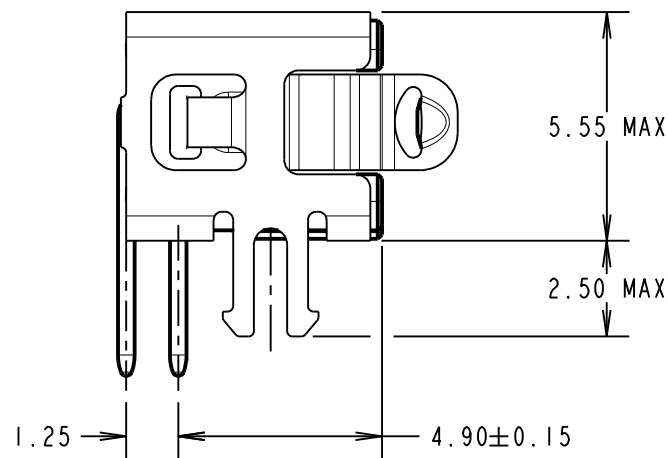

CONNECTOR DETAILS AND PCB LAYOUT ONLY.  
SEE SHEET 6 FOR TAPE AND STRIP DETAILS.

NOTES:  
1. FOR COMPLETE SPECIFICATION, SEE COMPONENT SPECIFICATION C125XX (LATEST ISSUE).  
SEE G125-SERIES CONNECTORS SPECIFICATION SHEET FOR MATERIALS, FINISH AND SPECIFICATION SUMMARY.

MR	2	08.11.18	20862
NAME	ISS.	DATE	C/NOTE
APPROVED: M.RUDKIN			
CHECKED: M.PLESTED			
DRAWN: MARK G PLESTED			
CUSTOMER REF.:			
ASSEMBLY DRG:			

**HARWIN**  
www.harwin.com  
technical@harwin.com

THIS DRAWING AND ANY INFORMATION OR DESCRIPTIVE MATTER SET OUT HEREON ARE CONFIDENTIAL AND COPYRIGHT PROPERTY OF THE HARWIN GROUP AND MUST NOT BE DISCLOSED, LOANED, COPIED OR USED FOR MANUFACTURING, TENDERING OR FOR ANY OTHER PURPOSE WITHOUT THEIR WRITTEN PERMISSION.

TOLERANCES  
X. = ±1mm  
X.X = ±0.50mm  
X.XX = ±0.10mm  
X.XXX = ±0.01mm  
ANGLES = ±5°  
UNLESS STATED

MATERIAL: SEE NOTE 1  
FINISH: SEE NOTE 1  
S/AREA: mm<sup>2</sup>

TITLE:  
G125 MALE HORIZONTAL PC TAIL SERIES  
DRAWING NUMBER:  
**G125-MHXXX05LIP**  
SHT 5 OF 6

# Customer Information Sheet

DRAWING No.: G125-MHXXX05LIP

IF IN DOUBT - ASK

©

NOT TO SCALE

THIRD ANGLE PROJECTION

ALL DIMENSIONS IN mm

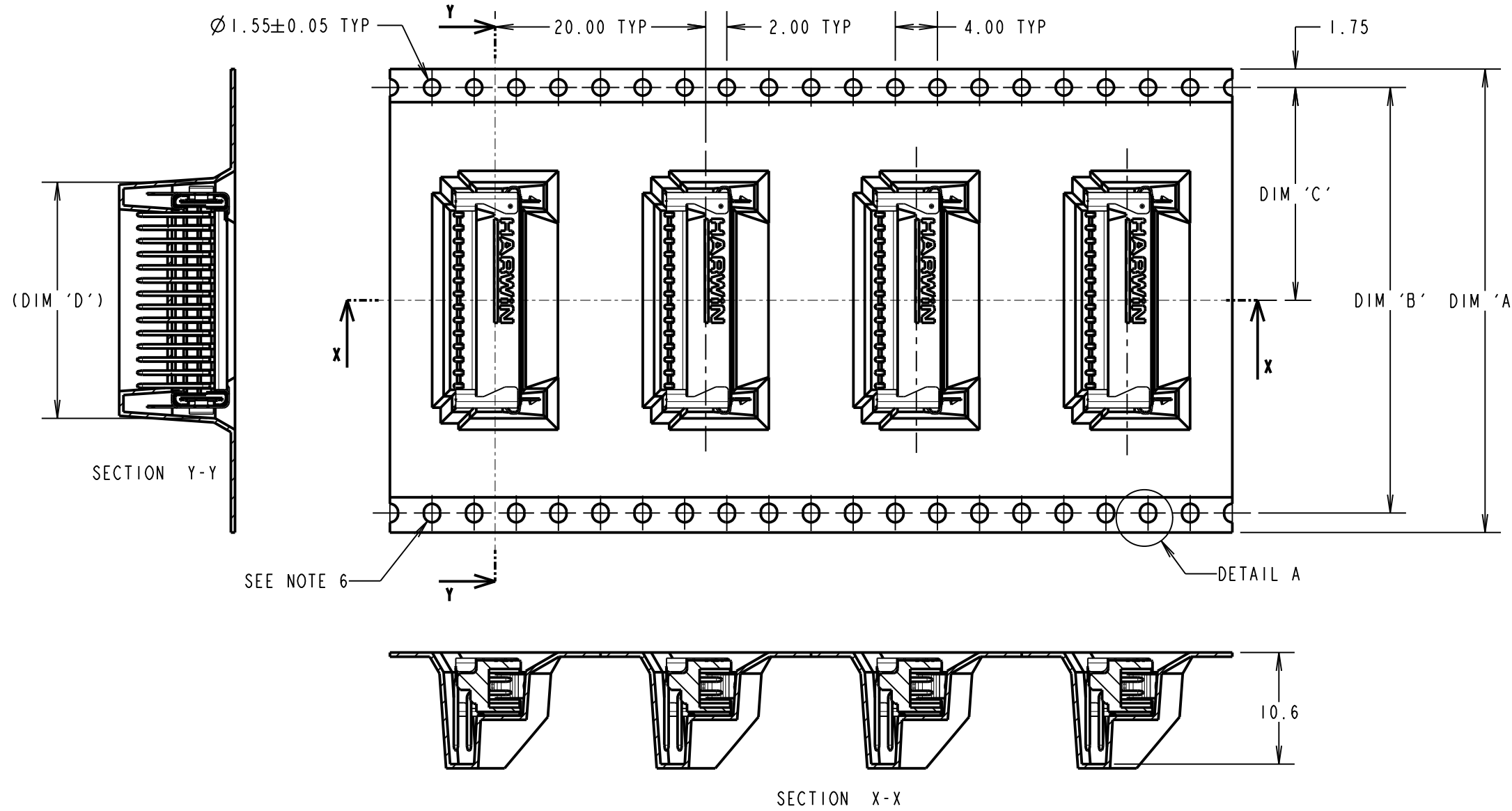

ORDER CODE:  
**G125-MHXXX05LIP**  
 3.3mm PC-TAILS = H1  
 4.8mm PC-TAILS = H2  
 TOTAL No. OF CONTACTS  
 06, 10, 12, 16, 20,  
 26, 34, 50.  
 LATCHES:  
 1.7mm PCB HOLD DOWN & LATCHES = LI

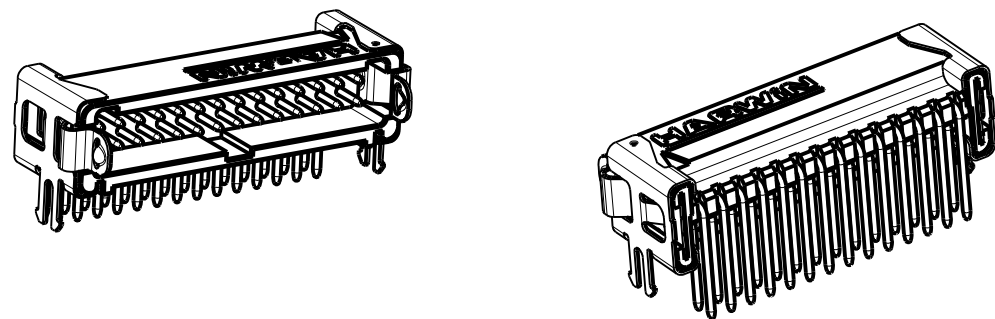
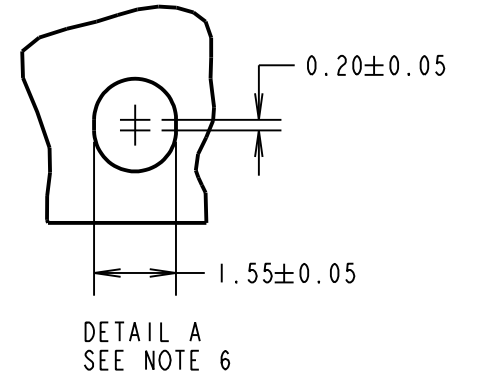

- NOTES:
- COMPONENTS ARE ORIENTED IN TAPE POCKETS AS SHOWN.
  - COMPONENTS ARE SUPPLIED IN STRIPS OF TAPE. SUPPLIED QUANTITY MAY CONSIST OF MORE THAN ONE STRIP. STRIP LENGTH MAY VARY.
  - LARGE QUANTITIES MAY BE SHIPPED ON A REEL AND MAY NOT HAVE A LEADER.
  - FOR PARTS ON A REEL SUITABLE FOR AUTOMATIC MACHINE PLACEMENT PLEASE ORDER: G125-MHXXX05LIR.
  - FOR COMPLETE SPECIFICATION, SEE COMPONENT SPECIFICATION C125XX (LATEST ISSUE).
  - ELONGATED SPROCKET HOLE NOT PRESENT ON 06 & 10 POSITIONS.
  - SEE SHEET 5 FOR CONNECTOR DETAILS.

PART No.	DIM 'A'	DIM 'B'	DIM 'C'	DIM 'D'
G125-MHX0605LIP	24.0	NO ELONGATED HOLE	11.50	8.5
G125-MHX1005LIP	+0.3/-0.1			11.0
G125-MHX1205LIP	32.0±0.3	28.40	14.20	12.2
G125-MHX1605LIP				14.7
G125-MHX2005LIP				17.2
G125-MHX2605LIP	44.0±0.3	40.40	20.2±0.15	21.0
G125-MHX3405LIP				26.0
G125-MHX5005LIP	56.0±0.3	52.40	26.2±0.15	36.0

MR	2	08.11.18	20862
NAME	ISS.	DATE	C/NOTE
APPROVED: M.RUDKIN			
CHECKED: M.PLESTED			
DRAWN: MARK G PLESTED			
CUSTOMER REF.:			
ASSEMBLY DRG:			

<p>www.harwin.com technical@harwin.com</p>	<p>THIS DRAWING AND ANY INFORMATION OR DESCRIPTIVE MATTER SET OUT HEREON ARE CONFIDENTIAL AND COPYRIGHT PROPERTY OF THE HARWIN GROUP AND MUST NOT BE DISCLOSED, LOANED, COPIED OR USED FOR MANUFACTURING, TENDERING OR FOR ANY OTHER PURPOSE WITHOUT THEIR WRITTEN PERMISSION.</p>	<p>TOLERANCES</p> <p>X. = ±1mm                  X.X = ±0.50mm                  X.XX = ±0.10mm                  X.XXX = ±0.01mm</p> <p>ANGLES = ±5°                  UNLESS STATED</p>	<p>MATERIAL:</p> <p>SEE SHEET 5</p>	<p>TITLE:</p> <p>G125 MALE HORIZONTAL PC TAIL SERIES</p>
		<p>FINISH: SEE SHEET 5</p> <p>S/AREA: mm<sup>2</sup></p>	<p>DRAWING NUMBER:</p> <p><b>G125-MHXXX05LIP</b></p>	<p>SHT</p> <p>6 OF 6</p>

# Customer Information Sheet

DRAWING No.: G125-SERIES COMPONENT SPECIFICATION

IF IN DOUBT - ASK

©

NOT TO SCALE

THIRD ANGLE PROJECTION

ALL DIMENSIONS IN mm

**SPECIFICATIONS:**

**MATERIALS:**

MOULDING, PICK & PLACE CAP:  
POLYAMIDE, PA4T-GF30 FR(40) UL94V-0,  
HALOGEN FREE, FREE OF RED PHOSPHORUS

**CONTACTS:**

SIGNAL CONTACTS:  
MALE PC-TAIL/SMT = PHOSPHOR BRONZE  
MALE CRIMP = BRASS  
ALL FEMALE CONTACTS = BERYLLIUM COPPER  
POWER CONTACTS:  
ALL CONTACTS = BERYLLIUM COPPER

**LOCKING HARDWARE:**

LATCHES: COPPER NICKEL TIN ALLOY  
SCREW LOCK: STAINLESS STEEL

BACK POTTING COMPOUND (CABLE ASSEMBLIES ONLY):  
STYCAST 2651 MM BACK POTTING WITH CATALYST 9

**FINISH:**

ALL SIGNAL CONTACTS:  
0.2-0.3µm GOLD OVER NICKEL  
ALL POWER CONTACTS:  
0.76-1.00µm GOLD OVER 1.50-2.50µm NICKEL  
AND COPPER FLASH  
LATCHES:  
3.0µm 100% TIN OVER NICKEL

**MECHANICAL:**

DURABILITY = 1000 OPERATIONS  
RETENTION IN HOUSING (ALL CONTACTS) = 6.0N MIN  
SIGNAL CONTACTS:  
INSERTION FORCE = 2.8N MAX  
WITHDRAWAL FORCE = 0.2N MIN  
POWER CONTACTS:  
INSERTION FORCE = 7.0N MAX  
WITHDRAWAL FORCE = 0.2N MIN  
SCREW-LOK:  
RETENTION IN HOUSING = 20.0N MIN  
LATCHES:  
RETENTION IN HOUSING = 4.0N MIN

**ENVIRONMENTAL:**

CLASSIFICATION: 65/150/56 DAYS AT 93% RH

**TEMPERATURE RANGE:**

\* EIA-364-32 : 2000 TEST CONDITION IV, DWELL  
30mins, 5 CYCLES -65°C TO +150°C

**MECHANICAL:**

**VIBRATION AND SHOCK:**

\* EIA-364-28D : 1999: TEST CONDITION IV: VIBRATION SEVERITY:  
10Hz TO 2000Hz, 1.5mm, 198mm/s<sup>2</sup> (20G). DURATION 2Hr  
\* EIA-364-28D : 1999: TEST CONDITION IV: VIBRATION SEVERITY:  
10Hz TO 2000Hz, 1.5mm, 198mm/s<sup>2</sup> (20G). DURATION 2Hr  
\* EIA-364-27B : 1996: TEST CONDITION E SHOCK SEVERITY: 981mm/s<sup>2</sup>  
(100G) FOR 6ms IN Z AXIS, 490mm/s<sup>2</sup> (50G) FOR 11ms IN X & Y AXIS.  
\* EIA-364-01A : 2000: ACCELERATION: 490mm/s<sup>2</sup> (50G)  
\* BUMP SEVERITY: 390mm/s<sup>2</sup> (40G), 4000±10 BUMPS  
\* TESTED WITH LATCHED CONNECTORS

**ELECTRICAL:**

**CURRENT RATING:**

**SIGNAL CONTACTS:**

EIA-364-70A : 1998: INDIVIDUAL CONTACT IN ISOLATION AT 25°C = 2.8A MAX  
EIA-364-70A : 1998: ALL CONTACTS SIMULTANEOUSLY AT 25°C = 2.0A MAX

**POWER CONTACTS:**

EIA-364-70A : 1998: PER CONTACT, THROUGH ALL CONTACTS = 10A MAX

**CONTACT RESISTANCE:**

EIA-364-06C : 2006: INITIAL CONTACT RESISTANCE = 20mΩ MAX  
EIA-364-06C : 2006: CONTACT RESISTANCE AFTER CONDITIONING = 25mΩ MAX

**VOLTAGE PROOF:**

EIA-364-20C : 2004: SEA LEVEL (1013mbar) = 600V DC/AC PEAK  
EIA-364-20C : 2004: ALTITUDE LEVEL (44mbar, 21,336m/70,000ft) = 350V DC/AC PEAK

**WORKING VOLTAGE:**

AT SEA LEVEL (1006mbar) = 450V DC/AC PEAK  
AT ALTITUDE (44mbar, 21,336m/70,000ft) = 250V DC/AC PEAK

**INSULATION RESISTANCE:**

EIA-364-21C : 2000: INSULATION RESISTANCE (INITIAL)  
= 10GΩ MIN AT 500V DC  
EIA-364-21C : 2000: INSULATION RESISTANCE (AFTER CONDITIONING)  
= >1GΩ MIN AT 500V DC

FOR FULL COMPONENT SPECIFICATION SEE C125XX (LATEST ISSUE).



PATENTED TECHNOLOGY

**HARWIN**

www.harwin.com  
technical@harwin.com

THIS DRAWING AND ANY INFORMATION OR DESCRIPTIVE MATTER SET OUT HEREON ARE CONFIDENTIAL AND COPYRIGHT PROPERTY OF THE HARWIN GROUP AND MUST NOT BE DISCLOSED, LOANED, COPIED OR USED FOR MANUFACTURING, TENDERING OR FOR ANY OTHER PURPOSE WITHOUT THEIR WRITTEN PERMISSION.

**TOLERANCES**

X. = ±1mm  
X.X = ±0.50mm  
X.XX = ±0.20mm  
X.XXX = ±0.01mm  
ANGLES = ±5°  
UNLESS STATED

**MATERIAL:**

SEE ABOVE

**FINISH:**

SEE ABOVE

**S/AREA:**

mm<sup>2</sup>

**TITLE:**

G125 SERIES COMPONENT SPECIFICATION

**DRAWING NUMBER:**

**G125-SERIES CONNECTORS**

SHT  
1 OF 1

RTP	5	04.10.19	22083
NAME	ISS.	DATE	C/NOTE
APPROVED:		R.PORTLOCK	
CHECKED:		S.BENNETT	
DRAWN:		S.FLOWER	
CUSTOMER REF.:			
ASSEMBLY DRG:			



Компания «ЭлектроПласт» предлагает заключение долгосрочных отношений при поставках импортных электронных компонентов на взаимовыгодных условиях!

Наши преимущества:

- Оперативные поставки широкого спектра электронных компонентов отечественного и импортного производства напрямую от производителей и с крупнейших мировых складов;
- Поставка более 17-ти миллионов наименований электронных компонентов;
- Поставка сложных, дефицитных, либо снятых с производства позиций;
- Оперативные сроки поставки под заказ (от 5 рабочих дней);
- Экспресс доставка в любую точку России;
- Техническая поддержка проекта, помощь в подборе аналогов, поставка прототипов;
- Система менеджмента качества сертифицирована по Международному стандарту ISO 9001;
- Лицензия ФСБ на осуществление работ с использованием сведений, составляющих государственную тайну;
- Поставка специализированных компонентов (Xilinx, Altera, Analog Devices, Intersil, Interpoint, Microsemi, Aeroflex, Peregrine, Syfer, Eurofarad, Texas Instrument, Miteq, Cobham, E2V, MA-COM, Hittite, Mini-Circuits, General Dynamics и др.);

Помимо этого, одним из направлений компании «ЭлектроПласт» является направление «Источники питания». Мы предлагаем Вам помощь Конструкторского отдела:

- Подбор оптимального решения, техническое обоснование при выборе компонента;
- Подбор аналогов;
- Консультации по применению компонента;
- Поставка образцов и прототипов;
- Техническая поддержка проекта;
- Защита от снятия компонента с производства.



#### Как с нами связаться

**Телефон:** 8 (812) 309 58 32 (многоканальный)

**Факс:** 8 (812) 320-02-42

**Электронная почта:** [org@eplast1.ru](mailto:org@eplast1.ru)

**Адрес:** 198099, г. Санкт-Петербург, ул. Калинина, дом 2, корпус 4, литера А.