

## HDP-20 Crimp Snap-In Contact Connectors



### Product Selection Guide

| Connector              |                                 |   |  | Contacts                   |                     |  |
|------------------------|---------------------------------|---|--|----------------------------|---------------------|--|
| Type                   | Insert Material                 | Shell Type Material and Finish              | Mounting   | Type                       | Termination         | Plating  |
| Plug<br>(pg. 92)       | 94V-0 Rated Thermoplastic Black | Zinc Plated Steel Without Grounding Indents | .120 [3.05] Dia. Holes<br>Clinch Nut, 4-40 Threads   | Pins<br>(pgs. 100, 101)    | Crimp<br><br>Posted | Duplex (.000030 [0.00076] Gold and Tin)        |
|                        |                                 | Tin Plated Steel Without Grounding Indents  |  |                            |                     | Duplex (Gold Flash and Tin)                    |
|                        |                                 | Tin Plated Steel With Grounding Indents     |  |                            |                     | Select (.000030 [0.00076] Gold and Gold Flash) |
| Receptacle<br>(pg. 93) | 94V-0 Rated Thermoplastic Black | Zinc Plated Steel                           | .120 [3.05] Dia. Holes<br>Clinch Nuts, 4-40 Threaded | Sockets<br>(pgs. 100, 101) | Crimp<br><br>Posted | Duplex (.000030 [0.00076] Gold and Tin)        |
|                        |                                 | Tin Plated Steel                            |  |                            |                     | Duplex (Gold Flash and Tin)                    |
|                        |                                 |   |  |                            |                     | Select (.000030 [0.00076] Gold and Gold Flash) |

**HDP-20 Crimp Snap-In Contact Connectors** (Continued)

**Product Facts**

- Shell sizes offer wide choice of contact positions—9, 15, 25, 37 and 50
- Lower cost, commercial version of the military approved series
- Tin or zinc plated shells, with or without grounding indents
- Crimp snap-in contacts allows loading of only the number of contacts being used
- Available with shielding hardware and shielding enclosure kits
- Numerous cable clamps and mating hardware options
- Low cost, high performance, precision-formed crimp contacts

- Machine applied terminations assure highest production rates at lowest applied cost
- Intermateable with any size 20 Subminiature D connector dimensionally complying with MIL-C-24308
- Recognized under the Component Program of Underwriters Laboratories Inc., File No. E28476
- Listed under Underwriters Laboratories Inc., Standard 1863, Communication Circuit Accessories, File No. E81956
- Certified by Canadian Standards Association, File No. LR 1088108 (LR 7189-207)

**Section Contents**

Plug and Receptacle Connectors ..... 92, 93  
 Basic Shielding Hardware Kits ..... 94, 95  
 Shielding Hardware Enclosure Kits ..... 96, 97  
 Preassembled Shielded Connector Kits ..... 98  
 Ferrules for Shielding Hardware Kits ..... 99  
 Contacts ..... 100, 101  
 Application Tooling ..... 102

| Unshielded Cable Clamps  | Shielded Cable Clamps and Shielding Hardware and Enclosure Kits   | Mounting and Mating Hardware  |
|--|---|---|
| <p>One-Piece Cable Clamp 180°/120° Quik-Snap (pg. 134)</p> <p>Box and Lid Straight/90° Exit (pg. 137)</p> <p>Box and Lid with Male Screw Retainers (pg. 137)</p> <p>Clam Shell Straight/45° Exit (pg. 138)</p> <p>Clam Shell Straight/45° Exit with Male Screw Retainers (pg. 138)</p> | <p>Straight Exit RFI/EMI Shields for Jacketed Cable (pgs. 139, 142)</p> <p>90° Exit Die Cast RFI/EMI Shields for Jacketed Cable (pg. 142)</p> <p>Basic Shielding Hardware Kits (pgs. 94, 95)</p> <p>Shielding Hardware Enclosure Kits (pgs. 96, 97)</p> | <p>Keying Plug (pg. 155)</p> <p>Male Screw Retainers (pgs. 146, 147)</p> <p>Female Screwlocks (pg. 148)</p> <p>Locking Posts and Slide Latches (pgs. 149, 151)</p> <p>Spring Latch, Two-Piece (pg. 152)</p> <p>Latching Blocks (pgs. 153, 154)</p> <p>Standoff Bushings (pg. 155)</p> |

**Contact Retention Features**



**HDP-20 Crimp Snap-In Contact Connectors** (Continued)



**Plug**



**Material and Finish:**  
**Shell**—Steel, zinc or tin plated  
**Insert**—94V-0 rated thermoplastic, black

**Mounting Holes:**  
**Standard**—.120 [3.05] Dia.  
**Clinch Nut**—4-40 threads with self-locking feature

- Related Product Data:**
- Contact Arrangements**—page 40
  - Performance Characteristics**—page 41
  - Contacts**—pages 100, 101
  - Application Tooling**—page 102
  - Mateable Connectors:**
    - HDE**—pages 110-123
    - HDP**—pages 90-102
    - HD-20 Board Mount**—pages 54-71, 78-85, 87-89
  - Mating/Panel Mounting**—page 42
  - Cable Clamps**—pages 132, 133, 135-137, 140, 141, 144, 145
  - Mating Hardware**—pages 146-150, 153, 155

- Technical Documents:**
- Product Specification**—108-40005
  - Application Specifications**—114-10000, 114-40030



**Clinch Nut**  
(Plug and Receptacle)

**Note:** Instruction Sheets for TE Tooling are packaged with the tooling. For additional information call the Tooling Assistance Center: **1-800-722-1111**.

**HDP-20 Crimp Snap-In Contact Connectors** (Continued)

**Receptacle**



| Shell Size | No. of Contact Positions | Dimensions     |                |               | Insert Material | Mounting Method | Plug Part Numbers |                           |                        | Receptacle Part Nos. |                  |
|------------|--------------------------|----------------|----------------|---------------|-----------------|-----------------|-------------------|---------------------------|------------------------|----------------------|------------------|
|            |                          | A              | B              | C             |                 |                 | Zinc Plated Shell | Tin Plated Shell          |                        | Zinc Plated Shell    | Tin Plated Shell |
|            |                          |                |                |               |                 |                 |                   | Without Grounding Indents | With Grounding Indents |                      |                  |
| 1          | 9                        | 1.213<br>30.81 | .984<br>24.99  | .494<br>12.55 | 94V-0           | Standard        | 205204-9          | 205204-8                  | 205204-4               | 205203-8             | 205203-3         |
|            |                          |                |                |               |                 | Clinch Nut      | —                 | 1658642-2                 | 1658642-1              | —                    | 1658643-1        |
| 2          | 15                       | 1.541<br>39.14 | 1.312<br>33.33 | .494<br>12.55 | 94V-0           | Standard        | 205206-9          | 205206-8                  | 205206-3               | 205205-7             | 205205-2         |
|            |                          |                |                |               |                 | Clinch Nut      | —                 | —                         | 5745908-2              | —                    | 1658644-1        |
| 3          | 25                       | 2.088<br>53.04 | 1.852<br>47.04 | .494<br>12.55 | 94V-0           | Standard        | 5205208-1         | 207464-7                  | 207464-2               | 5205207-1            | 207463-1         |
|            |                          |                |                |               |                 | Clinch Nut      | —                 | —                         | 5745036-2              | 207516-6             | 207516-5         |
| 4          | 37                       | 2.729<br>69.32 | 2.500<br>63.50 | .494<br>12.55 | 94V-0           | Standard        | 205210-8          | 205210-7                  | 205210-3               | 205209-7             | 205209-2         |
|            |                          |                |                |               |                 | Clinch Nut      | —                 | —                         | 745135-4               | —                    | 5207661-3        |
| 5          | 50                       | 2.635<br>66.93 | 2.406<br>61.11 | .605<br>15.37 | 94V-0           | Standard        | 1658641-3         | 1658641-1                 | 1658641-2              | 1658640-2            | 1658640-1        |
|            |                          |                |                |               |                 | Clinch Nut      | —                 | —                         | 5745883-2              | —                    | 5745884-1        |

**Note:** Plugs accept size 20 DF pin contacts and receptacles accept size 20 DF socket contacts.



**Clinch Nut**  
(Plug and Receptacle)

**Note:** Instruction Sheets for TE Tooling are packaged with the tooling. For additional information call the Tooling Assistance Center: **1-800-722-1111**.

**Note:** All part numbers are RoHS compliant.

## HDP-20 Basic Shielding Hardware Kits

### Plug



#### Each kit contains:

- Connector
- Inner shield
- Outer shield

Contacts and ferrules must be purchased separately.

#### Material and Finish:

**Connector Shells**—Steel, tin plated

**Connector Insert**—94V-0 rated thermoplastic, black

**Shield**—Steel, tin plated

#### Related Product Data:

**Contact Arrangements**—page 40

**Performance Characteristics**—page 41

**Contacts**—pages 100, 101

**Application Tooling**—page 102

#### Mateable Connectors:

**HDE**—pages 110-123

**HDP**—pages 90-102

**HD-20 Board Mount**—

pages 54-71, 78-85, 87-89

**Mating/Panel Mounting**—page 42

**Mating Hardware**—pages 146-150, 153, 155

**Ferrules**—page 99

#### Technical Documents:

**Product Specifications**—

108-40005

108-40030

**Application Specifications**—

114-10000

114-40030

**Instruction Sheet**—408-9010

**Note:** Instruction Sheets for TE Tooling are packaged with the tooling. For additional information call the Tooling Assistance Center: **1-800-722-1111**.

**HDP-20 Basic Shielding Hardware Kits (Continued)**

**Receptacle**



**Clinch Nut**  
(Plug and Receptacle)



View of Rear Shell  
(With Shields Removed)

| Shell Size | No. of Contact Positions | Dimensions |       | Recommended Cable Outer Dia. Range | Max. Inner Cable Bundle Dia.† | Mounting Method | Plug Kit Numbers | Receptacle Kit Numbers |
|------------|--------------------------|------------|-------|------------------------------------|-------------------------------|-----------------|------------------|------------------------|
|            |                          | D          | E     |                                    |                               |                 |                  |                        |
| 1          | 9                        | .700       | 1.535 | .165-.455                          | .350                          | Standard        | 1658645-1        | 1658646-1              |
|            |                          | 17.78      | 38.99 |                                    |                               | Clinch Nut      | 5748526-1        | 5748536-1              |
| 2          | 15                       | 1.024      | 1.535 | .165-.455                          | .350                          | Standard        | 1658647-1        | 5747539-1              |
|            |                          | 26.01      | 38.99 |                                    |                               | Clinch Nut      | 5750636-1        | 5787908-1              |
| 3          | 25                       | 1.576      | 1.535 | .165-.455                          | .350                          | Standard        | 1658648-1        | 1658649-1              |
|            |                          | 40.03      | 38.99 |                                    |                               | Clinch Nut      | —                | 1658662-1              |
| 4          | 37                       | 2.215      | 1.892 | .338-.562                          | .450                          | Standard        | 1658650-1        | 1658651-1              |
|            |                          | 56.26      | 48.06 |                                    |                               | Clinch Nut      | 5786929-1        | —                      |
| 5          | 50                       | 2.120      | 1.876 | .338-.480                          | .450                          | Standard        | 1658652-1        | 1658653-1              |
|            |                          | 53.85      | 47.65 |                                    |                               |                 |                  |                        |

**Notes:** 1. Plugs accept size 20 DF pin contacts and receptacles accept size 20 DF socket contacts.  
 2. Components of the kits are shipped unassembled and bulk-packaged in quantities of 100 pieces.  
 †Maximum cable diameter after jacket and braid removed.

**Note:** All part numbers are RoHS compliant.

## HDP-20 Shielding Hardware Enclosure Kits



### Plug

#### Each Kit Contains:

- Connector
- Inner shield
- Outer shield
- Enclosure
- Two jackscrews

Contacts and ferrules must be purchased separately.

#### Material and Finish:

**Connector Shells**—Steel, tin plated.

**Connector Insert**—94V-0 rated thermoplastic, black

**Shield**—Steel, tin plated

**Enclosure**—PVC, black

**Jackscrews**—Zinc alloy

#### Related Product Data:

**Contact Arrangements**—page 40

**Performance Characteristics**—page 41

**Contacts**—pages 100, 101

**Application Tooling**—page 102

#### Mateable Connectors:

**HDE**—pages 110-123

**HDP**—pages 90-102

**HD-20 Board Mount**—

pages 54-71, 78-85, 87-89

**Mating/Panel Mounting**—page 42

**Mating Hardware**—pages 146-150, 153, 155

**Ferrules**—page 99

#### Technical Documents:

##### Product Specifications—

108-40005

108-40030

##### Application Specifications—

114-10000

114-40030

##### Instruction Sheet—408-9172

**Note:** Instruction Sheets for TE Tooling are packaged with the tooling. For additional information call the Tooling Assistance Center: **1-800-722-1111**.

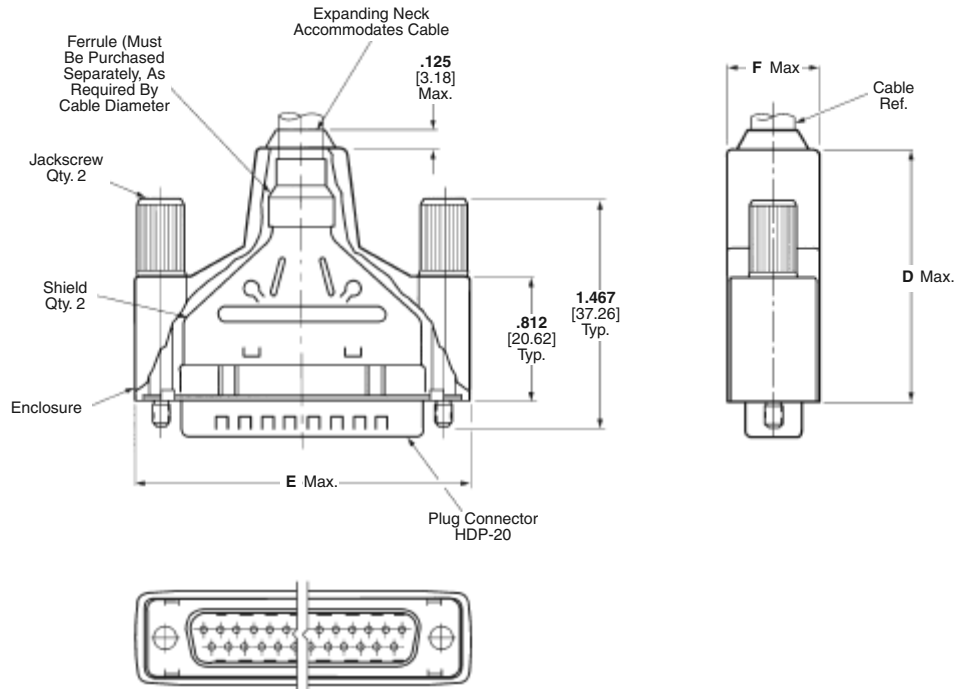



**HDP-20 Shielding Hardware Enclosure Kits** (Continued)

**Receptacle**



Cable Connectors

| Shell Size | No. of Contact Positions | Dimensions |       |       | Recommended Cable Outer Diameter Range | Max. Inner Cable Bundle Dia.† | Insert Material | Kit Numbers |            | Shielding Enclosure Expansion Tool |             |
|------------|--------------------------|------------|-------|-------|--|-------------------------------|-----------------|-------------|------------|------------------------------------|-------------|
|            |                          | D          | E     | F     |  |                               |                 | Plug        | Receptacle | Cable O.D. (Max.)                  | Part Number |
| 1          | 9                        | 1.660      | 1.355 | .630  | .190-.330<br>4.83-8.38                 | .330<br>8.38                  | 94V-0           | 1658655-1   | 1658654-1  | .330<br>8.38                       | 58241-4     |
|            |                          | 42.16      | 34.42 | 16.00 |  |                               |                 |             |            |                                    |             |
| 2          | 15                       | 1.660      | 1.685 | .630  | .190-.330<br>4.83-8.38                 | .330<br>8.38                  | 94V-0           | 1658657-1   | 1658656-1  | .450<br>11.43                      | 58241-1     |
|            |                          | 42.16      | 42.80 | 16.00 |  |                               |                 |             |            |                                    |             |
| 3          | 25                       | 1.660      | 2.210 | .630  | .217-.435<br>5.51-11.05                | .350<br>8.89                  | 94V-0           | 1658659-1   | 1658658-1  | .572<br>14.52                      | 58241-2     |
|            |                          | 42.16      | 56.13 | 16.00 |  |                               |                 |             |            |                                    |             |
| 4          | 37                       | 2.010      | 2.865 | .730  | .338-.562<br>8.59-14.28                | .450<br>11.43                 | 94V-0           | 5747958-1   | 1658660-1  | .572<br>14.52                      | 58241-2     |
|            |                          | 51.05      | 72.77 | 18.54 |  |                               |                 |             |            |                                    |             |
| 5          | 50                       | 2.010      | 2.775 | .730  | .338-.562<br>8.59-14.28                | .450<br>11.43                 | 94V-0           | 1658661-1   | 5747959-1  | .572<br>14.52                      | 58241-2     |
|            |                          | 51.05      | 70.49 | 18.54 |  |                               |                 |             |            |                                    |             |

**Notes:** 1. Plugs accept size 20 DF pin contacts and receptacles accept size 20 DF socket contacts.  
 2. Components of the kits are shipped unassembled and bulk-packaged in quantities of 100 pieces.  
 †Maximum cable diameter after jacket and braid removed.

**Note:** All part numbers are RoHS compliant.



## Shielded Connector, Preassembled Kit

Designed to meet the requirements of Local Area Networking, this Subminiature D Shielded Connector Kit is available with slide latches attached to the receptacle. The receptacle is shielded and covered with a durable plastic enclosure. This shielding decreases emissions and provides an effective EMI/RFI barrier.

Preassembled connector kits are available in Subminiature D, shell size 2, 15-position configuration and accept crimp, snap-in HD-20 contacts. Contacts are available separately and allow for selective positioning.

Other sizes and styles can be made available, consult TE.



Receptacle  
Part No. 749246-1

### Material and Finish:

**Inserts**—94V-0 rated nylon, black

**Enclosures**—Elastomer, styrene polyolefin, or PVC, black

**Shields and Shells**—Carbon steel per ASTM A109, plated with .000200 [0.00508] min. tin over .000050 [0.00127] min. copper

**Note:** Instruction Sheets for TE Tooling are packaged with the tooling. For additional information call the Tooling Assistance Center: **1-800-722-1111**.

### Related Product Data:

**Contact Arrangements**—page 40

**Performance Characteristics**—page 41

**Contacts**—pages 100, 101

**Application Tooling**—page 102

**Ferrules**—page 99

### Technical Documents:

**Product Specifications**—108-40005, 108-40030, 108-40032

**Application Specifications**—114-10000 & 114-40030

**Note:** All part numbers are RoHS compliant.

## HDP-20 Ferrules for Shielding Hardware Kits

### Ferrules for Shielding Hardware Kits



Stepped



Straight



### Material and Finish:

Steel (annealed), tin plated

### Related Product Data:

Shielding Hardware and Enclosure Kits—pages 94-98

### Technical Documents:

#### Instruction Sheets—

408-9507  
408-9508  
408-9243  
408-9242

**Note:** Instruction Sheets for TE Tooling are packaged with the tooling. For additional information call the Tooling Assistance Center: **1-800-722-1111**.

| Shell Sizes | Style    | L Dim.        | Cable Diameter           | Part Numbers |           |
|-------------|----------|---------------|--------------------------|--------------|-----------|
|             |          |               |                          | Ferrule      | Die Sets* |
| 1-3         | Stepped  | .440<br>11.18 | .165-.190<br>4.19-4.83   | 3-747579-0   | 543424-3  |
| 1-3         | Stepped  | .440<br>11.18 | .190-.217<br>4.83-5.51   | 3-747579-0   | 543424-2  |
| 1-3         | Stepped  | .440<br>11.18 | .217-.246<br>5.51-6.25   | 3-747579-0   | 543424-8  |
| 1-3         | Stepped  | .440<br>11.18 | .246-.284<br>6.25-7.21   | 3-747579-2   | 543424-1  |
| 1-3         | Stepped  | .440<br>11.18 | .284-.324<br>7.21-8.23   | 3-747579-2   | 543424-7  |
| 1-3         | Stepped  | .440<br>11.18 | .324-.375<br>8.23-9.53   | 3-747579-4   | 543424-6  |
| 1-3         | Straight | .440<br>11.18 | .375-.437<br>9.53-11.10  | 2-747579-7   | 543424-5  |
| 1-3         | Straight | .440<br>11.18 | .400-.460<br>10.16-11.56 | 3-747579-6   | 543424-4  |
| 4-5         | Stepped  | .625<br>15.88 | .230-.265<br>5.84-6.73   | 2-747580-4   | 543425-2  |
| 4-5         | Stepped  | .625<br>15.88 | .338-.385<br>8.59-9.78   | 2-747580-3   | 543425-1  |
| 4-5         | Stepped  | .625<br>15.88 | .375-.432<br>9.53-10.97  | 2-747580-1   | 58238-1   |
| 4-5         | Stepped  | .625<br>15.88 | .422-.490<br>10.72-12.45 | 3-747580-1   | 58237-2   |
| 4-5         | Straight | .625<br>15.88 | .480-.562<br>12.19-14.28 | 2-747580-2   | 58237-1   |

\*Die sets used with Hand Crimping Tool Part No. 543344-1 or Pneumatic Bench Tool Part No. 312522-3 equipped with Die Set Holder Part No. 58449-1.

### Application Tooling for Shielding Hardware Kits



Hand Crimping Tool  
No. 543344-1  
(Requires Die Sets, see table above.)



Shielding Enclosure Expansion Tools  
Part No. 58241-1 (.450 [11.43])†  
58241-2 (.572 [14.53])†  
58241-4 (.330 [8.38])†  
†Maximum Cable Diameter (Instruction Sheet—408-9172)

Pneumatic Bench Tool  
No. 312522-3  
(Requires Die Set Holder No. 58449-1.)



**Note:** All part numbers are RoHS compliant.

## HDP-20 Connector Contacts, Precision Formed

### Contact Size 20 DF Pin Diameter .040 [1.02]

#### Material and Finish:

**Pin**—Brass

**Socket**—Phosphor bronze

#### Plated

**A**—Select—Gold flash over nickel on entire contact, with additional .000030 [0.00076] gold on mating end

**B**—Duplex—.000030 [0.00076] gold on mating end, tin on termination end, with entire contact nickel underplated

**C**—Gold flash over nickel on entire contact

**D**—Duplex—Gold flash on mating end, tin on termination end, with entire contact nickel underplated

#### Related Product Data:

**Performance Characteristics**—page 41

**Connectors used with:**  
**HDP**—pages 92-97

**Application Tooling**—page 102

#### Technical Documents:

**Product Specification**—108-40005

**Application Specifications**—114-10000  
114-40030

**Note:** Instruction Sheets for TE Tooling are packaged with the tooling. For additional information call the Tooling Assistance Center: **1-800-722-1111**.

### Crimp Snap-In Contacts

#### With Insulation Support

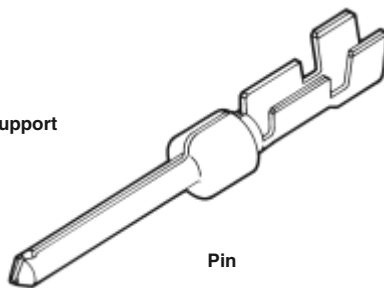

Pin

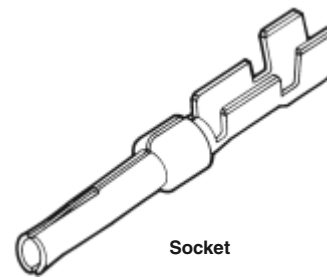

Socket

| Wire Size Range<br>AWG<br>[mm <sup>2</sup> ] | Ins. Dia.<br>Max. | Contact Finish<br>(Plating Code) | Contact Part Numbers |            |             |            | Hand Tools for Loose Form Contacts |   |  |
|--|-------------------|----------------------------------|----------------------|------------|-------------|------------|------------------------------------|---|--|
|  |                   |                                  | Pin                  |            | Socket      |            | PRO-CRIMPER II<br>Hand Tool        | CERTI-CRIMP II<br>Hand Tool<br>(Color Code) | Applicators*<br>for Strip Form<br>Contacts |
|  |                   |                                  | Strip Form           | Loose Form | Strip Form  | Loose Form |                                    |   |  |
| 28-24<br>0.08-0.2                            | .040<br>1.02      | A                                | 66507-3              | 66507-9    | 66505-3     | 66505-9    | 58448-2                            | 91503-1<br>(Blue Dot)                       | 466423-4**<br>466901-1***                  |
|  |                   | B                                | 1658540-4            | 1658540-5  | 1658538-2   | —          |                                    |   |  |
|  |                   | C                                | 66507-4              | 1-66507-0  | 66505-4     | 1-66505-0  |                                    |   |  |
|  |                   | D                                | 1658540-1            | 1658540-2  | 1658538-3   | 1658538-1  |                                    |   |  |
| 26-22<br>0.15-0.4                            | .040<br>1.27      | A                                | 66682-2              | 66682-4    | 66683-2     | 66683-4    | —                                  | 91549-1<br>(Black Dot)                      | 466963-1***                                |
|  |                   | B                                | 5066682-9            | —          | 1-5066683-0 | —          |                                    |   |  |
|  |                   | C                                | 745254-3             | 745254-7   | 745253-3    | 745253-7   |                                    |   |  |
|  |                   | D                                | 1658544-3            | —          | 1658543-3   | —          |                                    |   |  |
| 24-20<br>0.2-0.6                             | .060<br>1.52      | A                                | 66506-3              | 66506-9    | 66504-3     | 66504-9    | 58448-2                            | 91503-1<br>(Red Dot)                        | 466422-4**<br>466900-1***                  |
|  |                   | B                                | 1658539-1            | 1658539-3  | 1658537-3   | 1658537-4  |                                    |   |  |
|  |                   | C                                | 66506-4              | 1-66506-0  | 66504-4     | 1-66504-0  |                                    |   |  |
|  |                   | D                                | 1658539-2            | 1658539-4  | 1658537-1   | 1658537-2  |                                    |   |  |

\*For Part Nos. of Special Applicators and Applicators for other model machines, call the TE Tooling Assistance Center at **1-800-722-1111**.

\*\*For use with AMP-O-ELECTRIC Model "G" Terminating Machine.

\*\*\*For use with AMP-O-MATIC Model II Stripper-Crimper Machine.

#### Without Insulation Support



Pin



Socket

| Wire Size Range<br>AWG<br>[mm <sup>2</sup> ] | Ins. Dia.<br>Max. | Contact Finish<br>(Plating Code) | Contact Part Numbers |            | Hand Tools for Loose Form Contacts          |  |
|--|-------------------|----------------------------------|----------------------|------------|---|--|
|  |                   |                                  | Pin                  | Socket     | CERTI-CRIMP II<br>Hand Tool<br>(Color Code) | Applicators*<br>for Strip Form<br>Contacts |
|  |                   |                                  | Strip Form           | Strip Form |   |  |
| 28-24<br>0.08-0.2                            | .068<br>1.73      | A                                | 205310-2             | 205311-3   | 91548-1<br>(Blue Dot)                       | 466903-1***                                |
|  |                   | A                                | 205202-2             | 205201-3   |   |  |
| 24-20<br>0.2-0.6                             | .068<br>1.73      | C                                | 205202-6             | 205201-6   | 91548-1<br>(Red Dot)                        | 466902-1***                                |
|  |                   | A                                | 745229-2             | 745230-2   |   |  |
| 22-18<br>0.4-0.8                             | .068<br>1.73      | B                                | 1658541-1            | 1658542-2  | 91513-1<br>(Green Dot)                      | 466996-1***                                |
|  |                   | C                                | 745229-5             | 745230-5   |   |  |
|  |                   | D                                | —                    | 1658542-1  |   |  |

**Note:** Wire insulation diameter is limited by the connector housing cavity and clearance for the insertion/extraction tool.

\*For Part Nos. of Special Applicators and Applicators for other model machines, call the TE Tooling Assistance Center at **1-800-722-1111**.

\*\*\*For use with AMP-O-MATIC Model II Stripper-Crimper Machine.

**Note:** All part numbers are RoHS compliant.

**HDP-20 Connector Contacts, Precision Formed** (Continued)

**Contact Size 20 DF  
Pin Diameter .040 [1.02]**

**Material and Finish:**

**Pin**—Brass

**Socket**—Phosphor bronze

**Plated:**

**A**—Duplex plated .000030 [0.00076] gold on mating end, with entire contact .000050 [0.00127] min. nickel under-plated

**B**—Duplex plated gold flash on mating end, with entire contact .000050 [0.00127] min. nickel underplated

**Related Product Data:**

**Performance Characteristics**—  
page 41

**Connectors used with:**  
HDP—pages 92, 93

**Technical Documents:**

**Product Specification**—108-40005

**Application Specifications**—  
114-10000  
114-40030

**Note:** Instruction Sheets for TE Tooling are packaged with the tooling. For additional information call the Tooling Assistance Center: **1-800-722-1111**.

**Contact Size 20 DF  
Pin Diameter .040 [1.02]**

**Material and Finish:**

**Pin**—Brass

**Socket**—Phosphor bronze

**Plated**—Gold flash over nickel on entire contact, with additional .000030 [0.00076] gold on mating end

**Related Product Data:**

**Performance Characteristics**—  
page 41

**Connectors used with:**  
HDP—pages 92-97

**Technical Documents:**

**Product Specification**—108-40005

**Application Specification**—  
114-40030

**Insertion/Extraction Tool  
No. 91285-1**

This tool includes interchangeable tips to Insert/Extract:

Size 22, 28-22 AWG [0.08-0.4 mm<sup>2</sup>]

Size 20, Posted Contacts

(Instruction Sheet—408-9404)

**.025 [0.64]  
Square Posted Contacts**

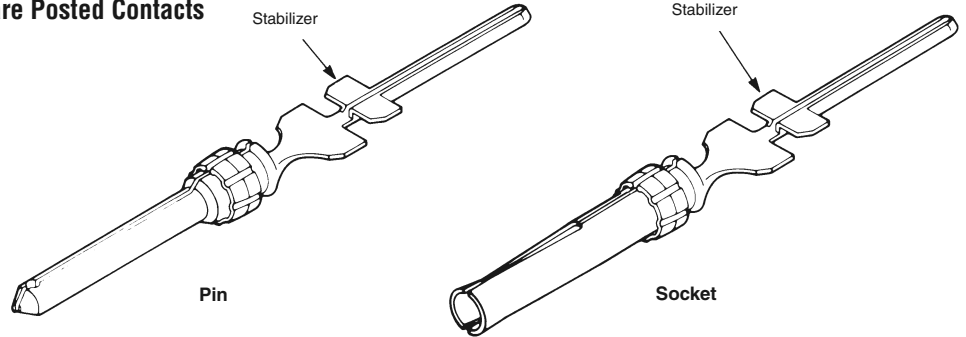

| Contact Finish (Plating Code) | Loose Form Contact Numbers |            |                          |            |                           |            |                           |            |
|-------------------------------|----------------------------|------------|--------------------------|------------|---------------------------|------------|---------------------------|------------|
|                               | .125 [3.18] Post Length*   |            | .188 [4.78] Post Length* |            | .427 [10.85] Post Length* |            | .651 [16.54] Post Length* |            |
|                               | Pin                        | Socket     | Pin                      | Socket     | Pin                       | Socket     | Pin                       | Socket     |
| A                             | —                          | 5-745288-5 | 5-745287-4               | 7-745288-0 | 4-745287-7                | 5-745288-8 | 5-745287-0                | 6-745288-1 |
| B                             | —                          | —          | —                        | —          | —                         | 7-745288-2 | —                         | 7-745288-2 |

\*Length of post extending from rear of HDP-20 metal-shell connector.

**Solder Cup Contacts,  
Snap-In**



**18 AWG Max. Wire (.046 [1.17] Max. Conductor Diameter)**

| Strip Form Contact Number |         | Loose Form Contact Number |         |
|---------------------------|---------|---------------------------|---------|
| Pin                       | Socket  | Pin                       | Socket  |
| 66570-2                   | 66569-2 | 66570-3                   | 66569-3 |



**Note:** Contacts to be soldered to wire before being inserted into housing

**Note:** All part numbers are RoHS compliant.

## HDP-20 Application Tooling

HDP-20 contacts may be applied by a variety of hand tools and machines. For low production runs, repairs and prototype work, we offer either our premium CERTI-CRIMP Hand Tool or our commercial PRO-CRIMPER II Hand Tool. For medium-volume production, you have the choice of our AMP-O-ELECTRIC Model "G" Terminating Machine, our new Model "M" Terminating Machine, or our AMP-O-MATIC Model II Stripper-Crimper Machine. The Stripper-Crimper is typically used for terminating the wires of jacketed cable. All three machines can be bench mounted.

For production requirements ranging from non-stop high volumes to countless series of short runs, our popular AMPOMATOR CLS IV+ fully-automated lead-making machine is an ideal choice.

For further information about these or other TE hand tools and machines, call the TE Tooling Assistance Center at **1-800-722-1111**.



### AMPOMATOR CLS IV+ Lead-Making Machine

This versatile machine now incorporates two AMP-O-ELECTRIC Model "G" Terminating Units. Basically, it produces single-wire leads in lengths from 1.62 [41.2] to 1000 [25 400]. It measures, cuts, strips and terminates wire sizes from 26 to 10 AWG [0.12 to 6 mm<sup>2</sup>] stranded and 26 to 16 AWG [0.12 to 1.4 mm<sup>2</sup>] solid. Production rates range up to 4800 leads per hour for 3 [76.2] lengths.

The machine is microprocessor controlled, and programmed and operated with

an easy-to-follow, menu-driven touchscreen. It can retain data for up to 200 lead assemblies. Off-line programming is also possible with optional software OffLine-Plus for Windows 95, **Part No. 189263-2**.

Air requirement is 90 psi [6.21] bar minimum at 15 scfm [0.0071 m<sup>3</sup>/s]. Power requirement is single-phase 220 VAC, 50 or 60 Hz, 25 A.

For further information request Catalog 124324.

**Note:** All part numbers are RoHS compliant.

## HDP-22 Crimp Snap-In Contact Connectors



### Product Selection Guide

| Connector         |                                  |   |                        |
|-------------------|----------------------------------|---|------------------------|
| Type              | Insert Material                  | Shell Type Material and Finish          | Mounting               |
| Plug<br>(pg. 105) | 94V-0 Rated Thermoplastic, Black | Tin Plated Steel with Grounding Indents | .120 [3.05] Dia. Holes |

| Contacts         |             |  |
|------------------|-------------|--|
| Type             | Termination | Plating  |
| Pin<br>(pg. 109) | Crimp       | Duplex (.000030 [0.00076] Gold and Tin)<br><br>Duplex (Gold Flash and Tin) |

|                         |                                  |                  |                        |
|-------------------------|----------------------------------|------------------|------------------------|
| Receptacle<br>(pg. 105) | 94V-0 Rated Thermoplastic, Black | Tin Plated Steel | .120 [3.05] Dia. Holes |
|-------------------------|----------------------------------|------------------|------------------------|

|                     |       |   |
|---------------------|-------|---|
| Socket<br>(pg. 109) | Crimp | Duplex (0.000030 [0.00076] Gold and Tin)<br><br>Duplex (Gold Flash and Tin) |
|---------------------|-------|---|



**HDP-22 Crimp Snap-In Contact Connectors** (Continued)

**Product Facts:**

- Approximately 65% higher density than HD-20 connectors
- Lower cost, commercial version of the military approved Series 90 family
- Available with shielding overmold hardware and shielding enclosure kits
- Capable of using numerous standard HD-20 cable clamps and mating hardware

- Low cost, high performance, precision-formed crimp contacts
- Intermateable with any size 22 Subminiature D connector dimensionally complying with MIL-C-24308
- Recognized under the Component Program of Underwriters Laboratories Inc.,  File No. E28476
- Listed under Underwriters Laboratories Inc., Standard 1863, Communication Circuit Accessories,  File No. E81956
- Certified by Canadian Standards Association, File No. LR 1088108  (LR 7189-207)

**Section Contents**

Plug and Receptacle Connectors ..... 105  
 Basic Shielding Hardware Kits ..... 106  
 Shielding Hardware Enclosure Kits ..... 107  
 Ferrules for Shielding Hardware Kits ..... 108  
 Contacts ..... 109  
 Application Tooling ..... 108, 109

| Unshielded Cable Clamps   | Shielded Cable Clamps and Shielding Hardware and Enclosure Kits | Mounting and Mating Hardware                    |
|---|---|---|
| One-Piece All Plastic Cable Clamp 180°/120° (Quik-Snap) (pg. 133) | Straight Exit RFI/EMI Shields for Jacketed Cable (pg. 141)      | Male Screw Retainers (pgs. 146, 147)            |
| Box and Lid Straight/90° Exit (pg. 137)                           | 90° Exit RFI/EMI Die Cast Shields For Jacketed Cable (pg. 142)  | Female Screwlocks (pg. 148)                     |
| Box and Lid Straight/90° Exit with Male Screw Retainers (pg. 137) | Basic Shielding Hardware Kits (pg. 106)                         | Locking Posts and Slide Latches (pgs. 149, 151) |
| Clam Shell Straight/45° Exit (pg. 138)                            | Shielding Hardware Enclosure Kits (pg. 107)                     | Two-Piece Spring Latch (pg. 152)                |
| Clam Shell Straight/45° Exit with Screw Retainers (pg. 138)       | Crimp & Split Ring Ferrules (pgs. 143-145)                      | Latching Blocks (pgs. 153, 154)                 |

**Contact Retention Features**





## HDP-22 Crimp Snap-In Contact Connectors (Continued)



**Plug**  
(With Grounding Indents)



**Receptacle**



**Clinch Nut**  
(Plug and Receptacle)

**Material and Finish:**

**Shell**—Steel, tin plated  
**Insert**—94V-0 rated thermoplastic, black  
 Contacts and ferrules must be purchased separately.

**Related Product Data:**

- Contact Arrangements**—page 40
- Performance Characteristics**—page 41
- Contacts**—page 109
- Ferrules**—page 108
- Mating/Panel Mounting**—page 42
- Cable Clamps**—pages 132, 133, 135-137, 140, 141, 144, 145
- Mating Hardware**—pages 146-150, 153, 155

**Technical Documents:**

- Application Specification**—114-10001
  - Product Specification**—108-1268
  - Instruction Sheets**—408-9381
- Note:** Instruction Sheets for TE Tooling are packaged with the tooling. For additional information call the Tooling Assistance Center: **1-800-722-1111**.

**Plug**

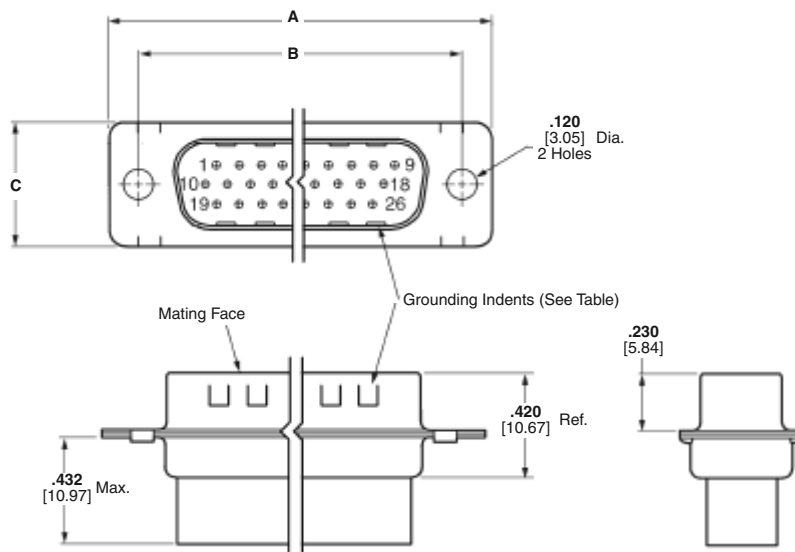

**Receptacle**



| Shell Size | No. of Contact Positions | Dimensions     |                |               | Part Numbers           |           |                  |            |
|------------|--------------------------|----------------|----------------|---------------|------------------------|-----------|------------------|------------|
|            |                          | A              | B              | C             | With Grounding Indents |           | With Clinch Nuts |            |
|            |                          |                |                |               | Plug                   | Plug      | Receptacle       | Receptacle |
| 1          | 15                       | 1.213<br>30.81 | .984<br>24.99  | .494<br>12.55 | 748364-1               | 1658691-1 | 1658681-1        | 1658690-1  |
| 2          | 26                       | 1.541<br>39.14 | 1.312<br>33.33 | .494<br>12.55 | 1658671-1              | 5749717-1 | 1658682-1        | 5788816-1  |
| 3          | 44                       | 2.088<br>53.84 | 1.852<br>47.04 | .494<br>12.55 | 1658672-1              | —         | 1658683-1        | 5786583-1  |
| 4          | 62                       | 2.729<br>69.32 | 2.500<br>63.50 | .494<br>12.55 | 1658673-1              | 6658293-1 | 1658684-1        | —          |
| 5          | 78                       | 2.635<br>66.93 | 2.406<br>61.11 | .605<br>15.37 | 1658674-1              | —         | 1658685-1        | 5788817-1  |

**Note:** Plugs accept size 22 DF pin contacts and receptacles accept size 22 DF socket contacts.

**Note:** All part numbers are RoHS compliant.

**HDP-22 Crimp Snap-In Contact Connectors** (Continued)

Cable Connectors

**Basic Shielding Hardware Kits**



Plug



Receptacle

**Each kit contains:**

- Connector
- Inner shield
- Outer shield

Contacts and ferrules must be purchased separately.

**Material and Finish:**

- Connector Shell**—Steel, tin plated
- Connector Insert**—94V-0 rated thermoplastic, black
- Shields**—Steel, tin plated

**Related Product Data:**

- Contact Arrangements**—page 40
- Performance Characteristics**—page 41
- Contacts**—page 109
- Ferrules**—page 108
- Application Tooling**—pages 108 & 109

**Mateable Connectors**—pages 105 & 107

**Mating Hardware**—pages 146-150, 153, 155

**Mating/Panel Mounting**—page 42

**Technical Documents:**

- Application Specifications**—114-10001
- Product Specification**—108-1268
- Instruction Sheet**—408-9381, 408-9010

**Note:** Instruction Sheets for TE Tooling are packaged with the tooling. For additional information call the Tooling Assistance Center: **1-800-722-1111**.

**Plug**

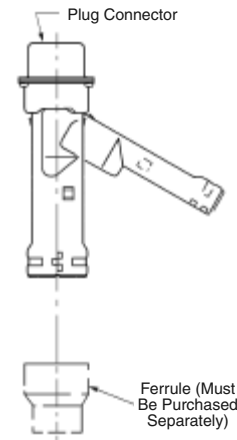

**Receptacle**

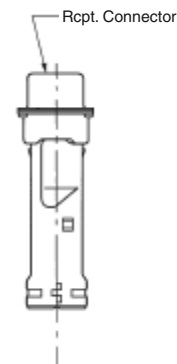

| Shell Size | No. of Contact Positions | Dimensions     |                | Recommended Cable Outer Dia. Range | Max. Inner Cable Bundle Dia.† | Kit Numbers |            |
|------------|--------------------------|----------------|----------------|------------------------------------|-------------------------------|-------------|------------|
|            |                          | C              | D              |                                    |                               | Plug        | Receptacle |
| 1          | 15                       | 1.535<br>38.99 | .700<br>17.78  | .165-.455<br>4.19-11.56            | .350<br>8.89                  | 1658675-1   | 5748634-1  |
| 2          | 26                       | 1.535<br>38.99 | 1.024<br>26.01 | .165-.455<br>4.19-11.56            | .350<br>8.89                  | 1658676-1   | 1658687-1  |
| 3          | 44                       | 1.535<br>38.99 | 1.576<br>40.03 | .165-.455<br>4.19-11.56            | .350<br>8.89                  | 1658677-1   | 5748636-1  |
| 4          | 62                       | 1.892<br>48.06 | 2.215<br>56.26 | .338-.562<br>8.59-14.28            | .450<br>11.43                 | 5748471-1   | —          |
| 5          | 78                       | 1.876<br>47.65 | 2.120<br>53.85 | .338-.490<br>8.59-12.45            | .450<br>11.43                 | 5748472-1   | —          |

**Notes:** 1. Plugs accept size 22 DF pin contacts and receptacles accept size 22 DF socket contacts.  
2. Components of the kits are shipped unassembled and bulk-packaged in quantities of 100 pieces.  
†Maximum cable diameter after jacket and braid removed.

**Note:** All part numbers are RoHS compliant.

### HDP-22 Crimp Snap-In Contact Connectors (Continued)

#### Shielding Hardware Enclosure Kits



Plug



Receptacle

#### Each kit contains:

- Connector
- Inner shield
- Outer shield
- Enclosure
- Two jackscrews

Contacts and ferrules must be purchased separately.

#### Material and Finish:

- Connector Shell**—Steel, tin plated
- Connector Insert**—94V-0 rated thermoplastic, black
- Shields**—Steel, tin plated
- Enclosure**—PVC, black
- Jackscrews**—Zinc alloy

#### Related Product Data:

- Contact Arrangements**—page 40
- Performance Characteristics**—page 41
- Contacts**—page 109
- Ferrules**—page 108

**Application Tooling**—pages 108 & 109

**Mateable Connectors**—pages 105 & 106

**Mating Hardware**—pages 146-150, 153-155

**Mating/Panel Mounting**—page 42

#### Technical Documents:

- Application Specifications**—114-10001
- Product Specification**—108-1268
- Instruction Sheet**—408-9381  
408-9172

**Note:** Instruction Sheets for TE Tooling are packaged with the tooling. For additional information call the Tooling Assistance Center: **1-800-722-1111**.

#### Plug

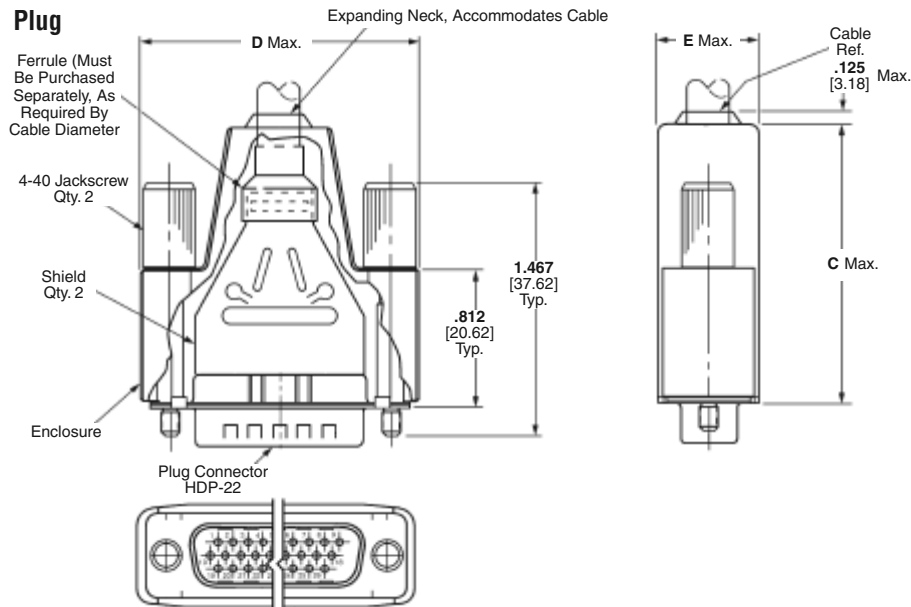

#### Receptacle



| Shell Size | No. of Contact Positions | Dimensions     |                |               | Recommended Cable Outer Diameter | Max. Inner Cable Bundle Dia.† | Kit Numbers |            | Shielding Enclosure Expansion Tool |             |
|------------|--------------------------|----------------|----------------|---------------|----------------------------------|-------------------------------|-------------|------------|------------------------------------|-------------|
|            |                          | C              | D              | E             |                                  |                               | Plug        | Receptacle | Cable O.D. (Max.)                  | Part Number |
| 1          | 15                       | 1.640<br>41.66 | 1.355<br>34.42 | .630<br>16.00 | .190-.330<br>4.83-8.38           | .330<br>8.38                  | 1658678-1   | 1658688-1  | .330<br>8.38                       | 58241-4     |
| 2          | 26                       | 1.640<br>41.66 | 1.685<br>42.80 | .630<br>16.00 | .190-.330<br>4.83-8.38           | .330<br>8.38                  | 1658679-1   | 1658689-1  |                                    |             |
| 3          | 44                       | 1.640<br>41.66 | 2.205<br>56.01 | .630<br>16.00 | .217-.435<br>5.51-11.05          | .350<br>8.89                  | 1658680-1   | 5748641-1  | .450<br>11.43                      | 58241-1     |
| 4          | 62                       | 2.010<br>51.05 | 2.860<br>72.64 | .730<br>18.54 | .338-.562<br>8.59-14.28          | .450<br>11.43                 | 5748476-1   | 5748642-1  | .572<br>14.52                      | 58241-2     |
| 5          | 78                       | 2.010<br>51.05 | 2.770<br>70.36 | .730<br>18.54 | .338-.490<br>8.59-12.45          | .450<br>11.43                 | 5748477-1   | —          |                                    |             |

**Notes:** 1. Plugs accept size 22 DF pin contacts and receptacles accept size 22 DF socket contacts.  
2. Components of the kits are shipped unassembled and bulk-packaged in quantities of 100 pieces.

†Maximum cable diameter after jacket and braid removed.

**Note:** All part numbers are RoHS compliant.

**HDP-22 Crimp Snap-In Contact Connectors** (Continued)

**Ferrules for Shielding Hardware Kits**

Stepped

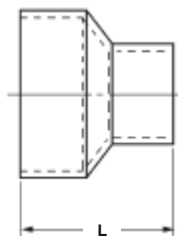

Straight

**Material and Finish:**

Steel (annealed), tin plated

**Related Product Data:**
**Shielding Hardware and Enclosure Kits**—pages 106 & 107

**Technical Documents:**
**Instruction Sheets**—

 408-9507  
 408-9508  
 408-9243  
 408-9242

**Note:** Instruction Sheets for TE Tooling are packaged with the tooling. For additional information call the Tooling Assistance Center: **1-800-722-1111**.

| Shell Sizes | Style    | L Dim.        | Cable Diameter           | Part Numbers |           |
|-------------|----------|---------------|--------------------------|--------------|-----------|
|             |          |               |                          | Ferrule      | Die Sets* |
| 1-3         | Stepped  | .440<br>11.18 | .165-.190<br>4.19-4.83   | 3-747579-0   | 543424-3  |
| 1-3         | Stepped  | .440<br>11.18 | .190-.217<br>4.83-5.51   | 3-747579-0   | 543424-2  |
| 1-3         | Stepped  | .440<br>11.18 | .217-.246<br>5.51-6.25   | 3-747579-0   | 543424-8  |
| 1-3         | Stepped  | .440<br>11.18 | .246-.284<br>6.25-7.21   | 3-747579-2   | 543424-1  |
| 1-3         | Stepped  | .440<br>11.18 | .284-.324<br>7.21-8.23   | 3-747579-2   | 543424-7  |
| 1-3         | Stepped  | .440<br>11.18 | .324-.375<br>8.23-9.53   | 3-747579-4   | 543424-6  |
| 1-3         | Straight | .440<br>11.18 | .375-.437<br>9.53-11.05  | 7-747579-7   | 543424-5  |
| 1-3         | Straight | .440<br>11.18 | .400-.460<br>10.16-11.56 | 3-747579-6   | 543424-4  |
| 4-5         | Stepped  | .625<br>15.88 | .230-.265<br>5.84-6.73   | 2-747580-4   | 543425-2  |
| 4-5         | Stepped  | .625<br>15.88 | .338-.385<br>8.59-9.78   | 2-747580-3   | 543425-1  |
| 4-5         | Stepped  | .625<br>15.88 | .375-.432<br>9.53-10.97  | 2-747580-1   | 58238-1   |
| 4-5         | Stepped  | .625<br>15.88 | .422-.490<br>10.72-12.45 | 3-747580-1   | 58237-2   |
| 4           | Straight | .625<br>15.88 | .480-.562<br>12.19-14.28 | 2-747580-2   | 58237-1   |

\*Die sets used with Hand Crimping Tool Part No. 543344-1 or Pneumatic Bench Tool Part No. 312522-3 equipped with Die Set Holder Part No. 58449-1.

**Application Tooling for Shielding Hardware Kits**

**Hand Crimping Tool**  
 No. 543344-1  
 (Requires Die Sets, see table above.)

**Shielding Enclosure Expansion Tools**  
 Part No. 58241-1 (.450 [11.43])†  
 58241-2 (.572 [14.53])†  
 58241-4 (.330 [8.38])†  
 †Maximum Cable Diameter  
 (Instruction Sheet—408-9507)

**Pneumatic Bench Tool**  
 No. 312522-3  
 (Requires Die Set Holder No. 58449-1.)

**Note:** All part numbers are RoHS compliant.

**HDP-22 Crimp Snap-In Contact Connectors** (Continued)

**Material**

**Pin**—Brass

**Socket**—Phosphor bronze

**Finish**

**A**—Duplex plated .000030 [0.00076] gold on mating end, tin on crimp barrel, with entire contact nickel underplated

**B**—Duplex plated gold flash on mating end, tin on crimp barrel, entire contact nickel underplated

**Related Product Data:**

**Performance Characteristics**—page 41

**Connectors used with**—pages 105-107

**Technical Documents:**

**Application Specification**—114-10001

**Product Specification**—108-1268

**Instruction Sheet**—408-9381

**Note:** Instruction Sheets for TE Tooling are packaged with the tooling. For additional information call the Tooling Assistance Center: **1-800-722-1111**.

**Precision Formed Crimp Snap-In Contacts, Size 22 DF**

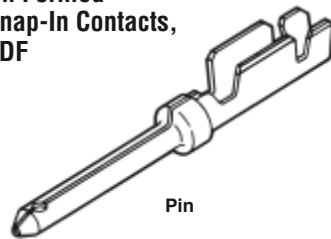

Pin

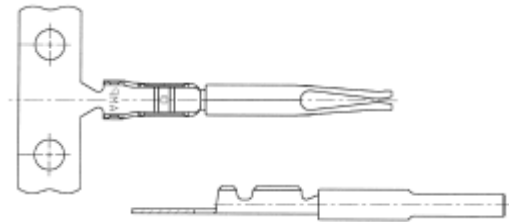

Socket

| Wire Size AWG mm <sup>2</sup> | Insulation Diameter Max. | Contact Finish (Plating Code) | Contact Part Numbers |            |            |            | Hand Tools for Loose Form Contacts |                          |
|-------------------------------|--------------------------|-------------------------------|----------------------|------------|------------|------------|------------------------------------|--------------------------|
|                               |                          |                               | Pin                  |            | Socket     |            | PRO-CRIMPER II Hand Tool           | CERTI-CRIMP II Hand Tool |
|                               |                          |                               | Strip Form           | Loose Form | Strip Form | Loose Form |                                    |                          |
| 28-22<br>0.4-0.08             | .040<br>1.02             | A                             | 1658670-1            | 1658670-2  | 1658686-1  | 1658686-2  | 90800-1                            | 91520-1                  |
|                               |                          | B                             | 1658670-3            | 1658670-4  | 1658686-3  | 1658686-4  |                                    |                          |

**Notes:** 1. Strip form contacts shipped 20,000 pieces/reel.

**Insertion/Extraction Tool No. 91285-1 (Instruction Sheet—408-9404)**

This tool contains interchangeable tips to Insert/Extract Size 22, 28-22 AWG [0.08-0.4 mm<sup>2</sup>] Crimp Contacts Size 20, 28-20 AWG [0.08-0.4 mm<sup>2</sup>] Crimp Contacts Size 20, Posted Contacts

Cable Connectors

**Application Tooling**



**Applicators**

To accommodate the broad range of wire termination products that TE produces, most TE terminating machines are designed for use with interchangeable applicators. The basic styles are quickly interchangeable to minimize costly down times, and feature dial-in wire and insulation crimp-height settings. Special applicators are now available for use with the AMP Crimp Quality Monitor, for measuring the crimp height of each termination as it is made, plus evaluating the quality of each crimp.

For further information, request Catalog 65404.

For applicator part numbers, call the TE Tooling Assistance Center at **1-800-722-1111**.



**AMP-O-LECTRIC MODEL "G" Terminating Machine**

A totally new design of our most popular machine for bench-top operation. It features a quiet and highly-reliable direct motor drive, electronic controls for ease of setup and operation, and improved guarding and lighting for operator convenience and safety. All versions also include either manual or automatic precision adjustment for crimp height. Power requirement is 120 or 220 VAC, 50 or 60 Hz.

For further information, request Catalog 65828.



**AMP-O-MATIC Model II Stripper-Crimper Machine**

This machine automatically strips as well as terminates individual wires. Similar to the AMP-O-LECTRIC Model "G" machine, applicators are quickly interchangeable, and it includes precision adjustment for crimp height. All adjustments can be made from the front of the machine without special tools. Power requirement is 120 VAC. Air requirement is 80-100 psi [5.52-6.89 bar], 3.5 scfm [0.00165 m<sup>3</sup>/s].

For further information request Catalog 65004.



**PRO-CRIMPER II Hand Tool Part No. 90800-1**

Features interchangeable die sets and ratchet control that provides full die closure to help eliminate partial crimps. The new design is more durable, and requires dramatically less hand force.

For further information, request Catalog 82276.

**Note:** All part numbers are RoHS compliant.



## HDE-20 IDC Connectors for Discrete Wire and Jacketed Cable





### Product Selection Guide

| Connector             |                                  |                                |                        | Contacts Pre-Loaded* |   |   |
|-----------------------|----------------------------------|--------------------------------|------------------------|----------------------|---|---|
| Type                  | Insert Material                  | Shell Type Material and Finish | Mounting               | Type                 | Termination   | Plating                                 |
| <b>Plug</b>           |                                  |                                |                        |                      |   |   |
| All-Plastic (pg. 112) | 94V-0 Rated Thermoplastic, Black | Tin Plated Steel               | .120 [3.05] Dia. Holes | Pins                 | Insulation Displacement<br><br>* Interchangeable crimp snap-in contacts available, see page 121 | Duplex (.000030 [0.00076] Gold and Tin) |
| Metal-Shell (pg. 114) |                                  |                                |                        |                      |   | Duplex (Gold Flash and Tin)             |
| <b>Receptacle</b>     |                                  |                                |                        |                      |   |   |
| All-Plastic (pg. 113) | 94V-0 Rated Thermoplastic, Black | Tin Plated Steel               | .120 [3.05] Dia. Holes | Sockets              | Insulation Displacement<br><br>* Interchangeable crimp snap-in contacts available, see page 121 | Duplex (.000030 [0.00076] Gold and Tin) |
| Metal-Shell (pg. 115) |                                  |                                |                        |                      |   | Duplex (Gold Flash and Tin)             |

**HDE-20 IDC Connectors for Discrete Wire and Jacketed Cable** (Continued)

**Product Facts**

- Insulation displacement contacts preloaded in housings
- No wire stripping
- Post plated contacts with no bare edges
- Duplex plated contacts—gold on mating end and tin on crimp end
- Patented contact ensures reliable termination of a wide range of wire sizes and insulation diameters
- Removable contacts for replacement and repair

- Selective loading of contacts available
- Crimp snap-in contacts available for making jumpers between circuits
- Recognized under the Component Program of Underwriters Laboratories Inc., File No. E28476 
- Listed under Underwriters Laboratories Inc., Standard 1863, Communication Circuit Accessories, File No. E81956 
- Certified by Canadian Standards Association, File No. 1088108 (LR 7189-207) 

**Section Contents**

All-Plastic Plug and Receptacle Connectors ..... 112, 113  
 Metal-Shell Plug and Receptacle Connectors ..... 114, 115  
 Basic Shielding Hardware Kits ..... 116, 117  
 Shielding Hardware Enclosure Kits ..... 118, 119  
 Ferrules for Shielding Hardware Kits ..... 120  
 Interchangeable Contacts, Crimp Snap-In ..... 121  
 Application Tooling ..... 122, 123

**Typical Application Rates**

| Tool                | Rate          |
|---------------------|---------------|
| Pistol Style        | 7.4 Sec./Line |
| Arbor Tool          | 5.0 Sec./Line |
| CHAMPOMATOR Machine | 2.8 Sec./Line |

**Note:** Rates are based on total time to complete a double ended 25 position Jacketed Cable Assembly

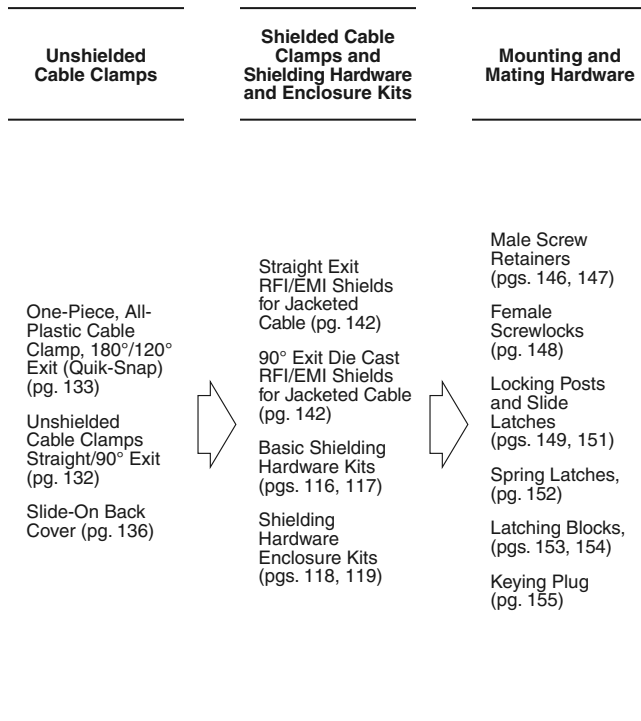



## HDE-20 All-Plastic IDC Connectors

### Plug



Plug

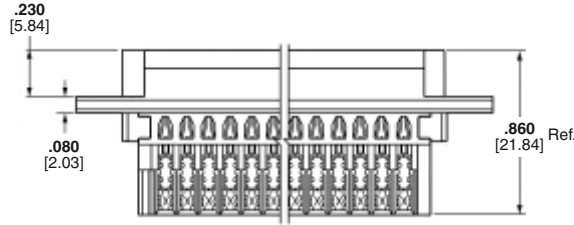

#### Material and Finish:

**Housing**—94V-0 rated thermoplastic, black

**Contacts**—Phosphor bronze

**Contact Finish**—Duplex plated:

**A**—0.00030 [0.00076] gold on mating end, tin on termination end, with entire contact nickel underplated

**B**—Gold flash on mating end, tin on termination end, with entire contact nickel underplated

#### Related Product Data:

**Contact Arrangements**—page 40

**Performance Characteristics**—page 41

**Interchangeable Crimp Snap-In Contacts**—page 121

**Application Tooling**—pages 121-123

**Mateable Connectors:**

**HDP**—pages 90-97

**HD-20 Board Mount**—pages 54-71, 78-85, 87-89

**Mating/Panel Mounting**—page 42

**Cable Clamps**—pages 132, 133, 135-137, 139, 140, 144, 145

**Mating Hardware**—pages 146-150, 153, 155

#### Technical Documents:

**Product Specification**—108-40011

**Application Specifications**—114-40002  
114-40003

**Instruction Sheet**—408-6621

**Note:** Instruction Sheets for TE Tooling are packaged with the tooling. For additional information call the Tooling Assistance Center: **1-800-722-1111**.

| Shell Size | No. of Contact Positions | Dimensions     |                | Contact Finish (Plating Code) | Connector Part Numbers   |   |
|------------|--------------------------|----------------|----------------|-------------------------------|--|---|
|            |                          | A              | B              |                               | Contact Identification No. 1 for 30-26 AWG [0.05-0.15mm <sup>2</sup> ] Wire Plug | Contact Identification No. 2 for 26-22 AWG [0.15-0.4mm <sup>2</sup> ] Wire Plug |
| 1          | 9                        | 1.213<br>30.81 | .984<br>24.99  | A                             | —  | 745203-2  |
|            |                          |                |                | B                             | —  | 1-745203-1  |
| 2          | 15                       | 1.541<br>39.14 | 1.312<br>33.33 | A                             | —  | 745207-7  |
|            |                          |                |                | B                             | —  | —   |
| 3          | 25                       | 2.090<br>53.09 | 1.852<br>47.04 | A                             | 745211-9   | 745211-7  |
|            |                          |                |                | B                             | —  | 745211-8  |
| 4          | 37                       | 2.732<br>69.39 | 2.500<br>63.50 | A                             | —  | 745215-7  |
|            |                          |                |                | B                             | —  | —   |

**Notes:** 1. All connectors are preloaded with insulation displacement contacts. Pins in plug connectors and sockets in receptacle connectors. Contacts accept a max. wire insulation thickness of .015 [0.38] and a max. wire insulation dia. of .060 [1.52].

2. HDE connectors are designed for terminating solid or stranded (7-strand max.) wire.

3. Individual conductor strands should be larger than .005 inch [0.127] diameter.

4. Extraction Tool Part No. 91232-1 (Instruction Sheet 408-6631) is used to remove pin or socket contacts.

5. For terminating more than one wire, or a drain wire, use crimp contacts on page 121.

**Note:** All part numbers are RoHS compliant.

## HDE-20 All-Plastic IDC Connectors (Continued)

### Receptacle



Receptacle



#### Material and Finish:

**Housing**—94V-0 rated thermoplastic, black

**Contacts**—Phosphor bronze

**Contact Finish**—Duplex plated:

**A**— $.000030$  [0.00076] gold on mating end, tin on termination end, with entire contact nickel underplated

**B**—Gold flash on mating end, tin on termination end, with entire contact nickel underplated

#### Related Product Data:

**Contact Arrangements**—page 40

**Performance Characteristics**—page 41

**Interchangeable Crimp Snap-In Contacts**—page 121

**Application Tooling**—pages 121-123

**Mateable Connectors:**

**HDP**—pages 90-97

**HD-20 Board Mount**—pages 54-71, 78-85, 87-89

**Mating/Panel Mounting**—page 42

**Cable Clamps**—pages 132, 133, 135-137, 139, 140, 144, 145

**Mating Hardware**—pages 146-150, 153, 155

#### Technical Documents:

**Product Specification**—108-40011

**Application Specifications**—114-40002  
114-40003

**Instruction Sheet**—408-6621

**Note:** Instruction Sheets for TE Tooling are packaged with the tooling. For additional information call the Tooling Assistance Center: **1-800-722-1111**.

| Shell Size | No. of Contact Positions | Dimensions     |                | Contact Finish (Plating Code) | Connector Part Numbers  |
|------------|--------------------------|----------------|----------------|-------------------------------|---|
|            |                          | A              | B              |                               | Contact Identification No. 2 for 26-22 AWG [0.15-0.4mm <sup>2</sup> ] Wire Receptacle |
| 1          | 9                        | 1.213<br>30.81 | .984<br>24.99  | A                             | 745201-7  |
|            |                          |                |                | B                             | 745201-9  |
| 2          | 15                       | 1.541<br>39.14 | 1.312<br>33.33 | A                             | 745205-7  |
|            |                          |                |                | B                             | 745209-7  |
| 3          | 25                       | 2.090<br>53.09 | 1.852<br>47.04 | A                             | 745209-7  |
|            |                          |                |                | B                             | 745209-8  |

- Notes:**
1. All connectors are preloaded with insulation displacement contacts. Pins in plug connectors and sockets in receptacle connectors. Contacts accept a max. wire insulation thickness of  $.015$  [0.38] and a max. wire insulation dia. of  $.060$  [1.52].
  2. HDE connectors are designed for terminating solid or stranded (7-strand max.) wire.
  3. Individual conductor strands should be larger than  $.005$  inch [0.127] diameter.
  4. Extraction Tool Part No. 91232-1 (Instruction Sheet 408-6631) is used to remove pin or socket contacts.
  5. For terminating more than one wire, or a drain wire, use crimp contacts on page 121.

**Note:** All part numbers are RoHS compliant.

## HDE-20 Metal-Shell IDC Connectors

### Plug

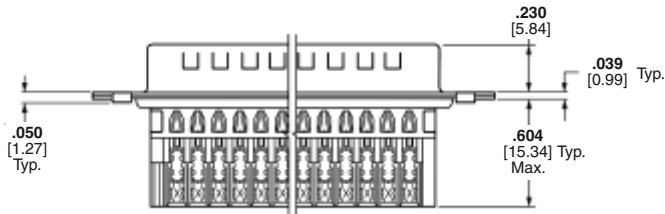
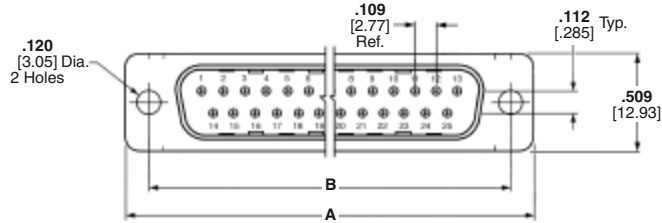

**Material and Finish:**

**Shell**—Steel, tin plated  
**Insert**—94V-0 rated thermoplastic, black

**Contacts**—Phosphor bronze  
**Contact Finish**—Duplex plated:  
**A**—.000030 [0.00076] gold on mating end, tin on termination end, with entire contact nickel underplated  
**B**—Gold flash on mating end, tin on termination end, with entire contact nickel underplated

**Related Product Data:**

- Contact Arrangements**—page 40
- Performance Characteristics**—page 41
- Interchangeable Crimp Snap-In Contacts**—page 121
- Application Tooling**—pages 121-123
- Mateable Connectors:**
  - HDP**—pages 90-97
  - HD-20 Board Mount**—pages 54-71, 78-85, 87-89
- Mating/Panel Mounting**—page 42
- Cable Clamps**—pages 132, 133, 135-137, 138, 140, 144, 145
- Mating Hardware**—pages 146-150, 153, 155

**Technical Documents:**

- Product Specification**—108-40011
- Application Specifications**—114-40002, 114-40003
- Instruction Sheet**—408-6645
- Note:** Instruction Sheets for TE Tooling are packaged with the tooling. For additional information call the Tooling Assistance Center: **1-800-722-1111**.

| Shell Size | No. of Contact Positions | Dimensions     |                | Contact Finish (Plating Code) | Connector Part Numbers  |  |   |
|------------|--------------------------|----------------|----------------|-------------------------------|---|--|---|
|            |                          |                |                |                               | Contact Identification No. 1 for 30-26 AWG [0.05-0.15mm <sup>2</sup> ] Wire | Contact Identification No. 2 for 26-22 AWG [0.15-0.4mm <sup>2</sup> ] Wire | Contact Identification No. 3 for 22-20 AWG [0.4-0.6mm <sup>2</sup> ] Wire |
|            |                          |                |                |                               | Plug  | Plug   | Plug  |
| 1          | 9                        | 1.213<br>30.81 | .984<br>24.99  | A                             | 1-745492-7  | 1-745492-8   | 1-745492-9  |
|            |                          |                |                | B                             | —   | 2-745492-0   | —   |
| 2          | 15                       | 1.541<br>39.14 | 1.312<br>33.33 | A                             | 1-745494-7  | 1-745494-5   | —   |
|            |                          |                |                | B                             | —   | 1-745494-6   | —   |
| 3          | 25                       | 2.088<br>53.04 | 1.852<br>47.04 | A                             | 1-745496-9  | 1-745496-7   | 2-745496-0  |
|            |                          |                |                | B                             | —   | 1-745496-8   | —   |
| 4          | 37                       | 2.729<br>69.32 | 2.500<br>63.50 | A                             | 1-745498-6  | 1-745498-5   | —   |
|            |                          |                |                | B                             | —   | 1-745498-7   | —   |

- Notes:**
1. All connectors are preloaded with insulation displacement contacts. Pins in plug connectors and sockets in receptacle connectors. Contacts accept a max. wire insulation thickness of .015 [0.38] and a max. wire insulation dia. of .060 [1.52].
  2. Connectors can be made available with clinch nuts, contact TE.
  3. HDE connectors are designed for terminating solid or stranded (7-strand max.) wire.
  4. Individual conductor strands should be larger than .005 inch [0.127] diameter.
  5. Extraction Tool Part No. 91232-1 (Instruction Sheet 408-6631) is used to remove pin or socket contacts.
  6. For terminating more than one wire, or a drain wire, use crimp contacts on page 121.

**Note:** All part numbers are RoHS compliant.

## HDE-20 Metal-Shell IDC Connectors (Continued)

### Receptacle

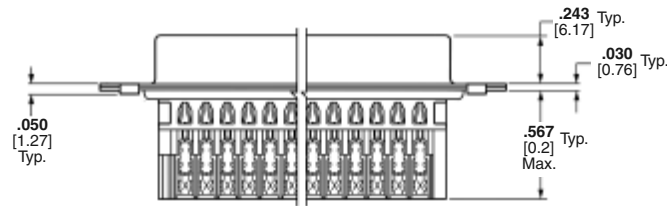

#### Material and Finish:

**Shell**—Steel, tin plated

**Insert**—94V-0 rated thermoplastic, black

**Contacts**—Phosphor bronze

**Contact Finish**—Duplex plated:  
**A**—.000030 [0.00076] gold on mating end, tin on termination end, with entire contact nickel underplated

**B**—Gold flash on mating end, tin on termination end, with entire contact nickel underplated

#### Related Product Data:

**Contact Arrangements**—page 40

**Performance Characteristics**—page 41

**Interchangeable Crimp Snap-In Contacts**—page 121

**Application Tooling**—pages 121-123

#### Mateable Connectors:

**HDP**—pages 90-97

**HD-20 Board Mount**—pages 54-71, 78-85, 87-89

**Mating/Panel Mounting**—page 42

**Cable Clamps**—pages 132, 133, 135-137, 139, 140, 144, 145

**Mating Hardware**—pages 146-150, 153, 155

#### Technical Documents:

**Product Specification**—108-40011

**Application Specifications**—114-40002  
114-40003

**Instruction Sheet**—408-6645

**Note:** Instruction Sheets for TE Tooling are packaged with the tooling. For additional information call the Tooling Assistance Center: **1-800-722-1111**.

| Shell Size | No. of Contact Positions | Dimensions     |                | Contact Finish (Plating Code) | Connector Part Numbers  |  |   |
|------------|--------------------------|----------------|----------------|-------------------------------|---|--|---|
|            |                          | A              | B              |                               | Contact Identification No. 1 for 30-26 AWG [0.05-0.15mm <sup>2</sup> ] Wire | Contact Identification No. 2 for 26-22 AWG [0.15-0.4mm <sup>2</sup> ] Wire | Contact Identification No. 3 for 22-20 AWG [0.4-0.6mm <sup>2</sup> ] Wire |
|            |                          | Receptacle     | Receptacle     |                               | Receptacle  |  |   |
| 1          | 9                        | 1.213<br>30.81 | .984<br>24.99  | A                             | 1-745491-6  | 1-745491-7   | 1-745491-9  |
|            |                          |                |                | B                             | —   | 1-745491-8   | —   |
| 2          | 15                       | 1.541<br>39.14 | 1.312<br>33.33 | A                             | 1-745493-6  | 1-745493-4   | —   |
|            |                          |                |                | B                             | —   | 1-745493-5   | —   |
| 3*         | 25                       | 2.088<br>53.04 | 1.852<br>47.04 | A                             | 1-745495-7  | 1-745495-8   | 1-745495-9  |
|            |                          |                |                | B                             | —   | 2-745495-0   | —   |
| 4          | 37                       | 2.729<br>69.32 | 2.500<br>63.50 | A                             | 1-745497-6  | 1-745497-5   | —   |
|            |                          |                |                | B                             | —   | 1-745497-7   | —   |

\* RS-232, size 3 connector, for 26-22 [0.15-0.4mm<sup>2</sup>] AWG wire select loaded circuits 1-8,15,17, 20 and 22, Plug Part No. 747740-1, Receptacle Part No. 747741-1, gold flash contacts.

- Notes:**
- All connectors are preloaded with insulation displacement contacts. Pins in plug connectors and sockets in receptacle connectors. Contacts accept a max. wire insulation thickness of .015 [0.38] and a max. wire insulation dia. of .060 [1.52].
  - Connectors can be made available with clinch nuts, contact TE.
  - HDE connectors are designed for terminating solid or stranded (7-strand max.) wire.
  - Individual conductor strands should be larger than .005 inch [0.127] diameter.
  - Extraction Tool Part No. 91232-1 (Instruction Sheet 408-6631) is used to remove pin or socket contacts.
  - For terminating more than one wire, or a drain wire, use crimp contacts on page 121.

**Note:** All part numbers are RoHS compliant.

## HDE-20 Basic Shielding Hardware Kits

**Each kit contains:**

- Connector
- Inner shield
- Outer shield

Ferrules must be purchased separately.

**Material and Finish:**
**Connector Shell**—Steel, tin plated

**Connector Insert**—94V-0 rated thermoplastic, black

**Shield**—Steel, tin plated

**Contacts**—Phosphor bronze

**Contact Finish**—Duplex plated:

**A**—.000030 [0.00076] gold on mating end, tin on termination end, with entire contact nickel underplated

**B**—Gold flash on mating end, tin on termination end, with entire contact nickel underplated

**Related Product Data:**
**Contact Arrangements**—page 40

**Performance Characteristics**—page 41

**Application Tooling**—pages 121-123

**Mateable Connectors:**
**HDP**—pages 90-97

**HD-20 Board Mount**—pages 54-71, 78-85, 87-89

**Mating Hardware**—pages 146-150, 153, 155

**Mating/Panel Mounting**—page 42

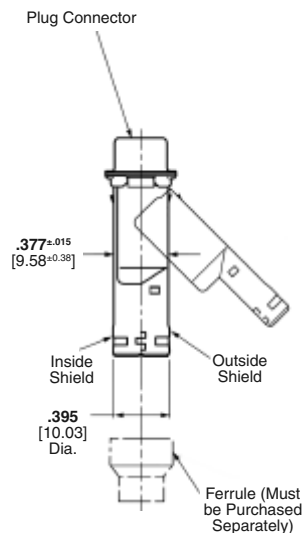
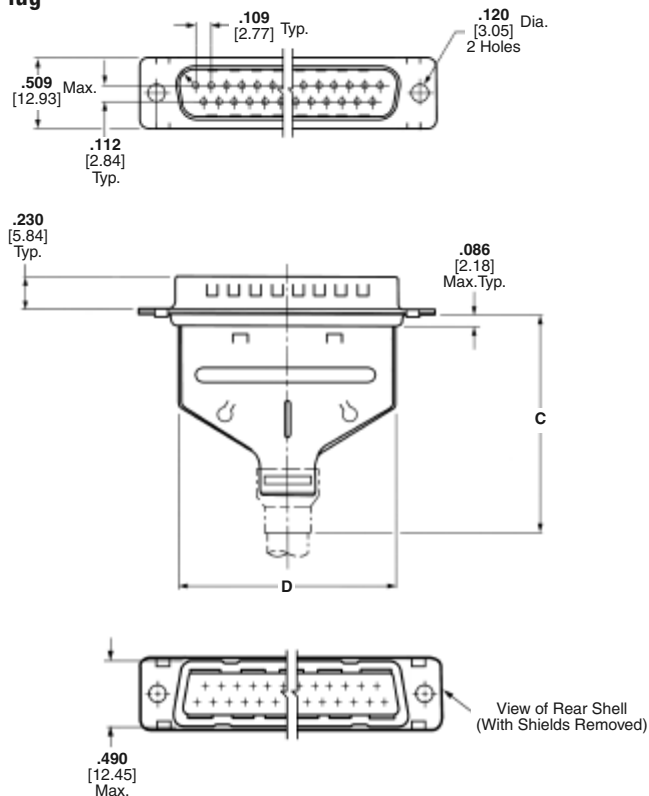
**Plug**

**Technical Documents:**
**Product Specifications**—

108-40011

108-40030

**Application Specifications**—

114-40002

114-40003

114-40006

**Instruction Sheet**—408-9010

**Note:** Instruction Sheets for TE Tooling are packaged with the tooling. For additional information call the Tooling Assistance Center: **1-800-722-1111**.

| Shell Size | No. of Contact Pos. | Dimensions     |                | Recommended Cable Outer Dia. Range | Max. Inner Cable Bundle Dia.† | Contact Finish (Plating Code) | Connector Part Numbers  |  |   |
|------------|---------------------|----------------|----------------|------------------------------------|-------------------------------|-------------------------------|---|--|---|
|            |                     |                |                |                                    |                               |                               | Contact I.D. No. 1 for 30-26 AWG [0.05-0.15mm <sup>2</sup> ] Wire | Contact I.D. No. 2 for 26-22 AWG [0.15-0.4mm <sup>2</sup> ] Wire | Contact I.D. No. 3 for 22-20 AWG [0.4-0.6mm <sup>2</sup> ] Wire |
|            |                     |                |                |                                    |                               |                               | Plug  | Plug   | Plug  |
| 1          | 9                   | 1.520<br>38.61 | .678<br>17.22  | .165-.455<br>4.19-11.56            | .350<br>8.89                  | A                             | —   | 747515-7   | —   |
|            |                     |                |                |                                    |                               |                               | 747531-7  | 747531-8   | —   |
| 2          | 15                  | 1.520<br>38.61 | 1.002<br>25.45 | .165-.455<br>4.19-11.56            | .350<br>8.89                  | A<br>B                        | —   | 747531-9   | —   |
|            |                     |                |                |                                    |                               |                               | 747547-8  | 747547-9   | —   |
| 3          | 25                  | 1.520<br>38.61 | 1.550<br>39.37 | .165-.455<br>4.19-11.56            | .350<br>8.89                  | A<br>B                        | —   | 1-747547-0   | —   |
|            |                     |                |                |                                    |                               |                               | —   | —  | —   |
| 4          | 37                  | 1.867<br>47.42 | 2.205<br>56.01 | .338-.562<br>8.59-14.28            | .450<br>11.43                 | A<br>B                        | —   | —  | —   |
|            |                     |                |                |                                    |                               |                               | —   | 1-747563-0   | —   |

**Note:** Components of the kits are shipped unassembled and bulk-packaged in quantities of 100 pieces.

†Maximum cable diameter after jacket and braid removed.

**Note:** All part numbers are RoHS compliant.

## HDE-20 Basic Shielding Hardware Kits (Continued)



**Each kit contains:**

- Connector
- Inner shield
- Outer shield

Ferrules must be purchased separately.

**Material and Finish:**

**Connector Shell**—Steel, tin plated

**Connector Insert**—94V-0 rated thermoplastic, black

**Shield**—Steel, tin plated

**Contacts**—Phosphor bronze

**Contact Finish**—Duplex plated:

**A**—0.00030 [0.00076] gold on mating end, tin on termination end, with entire contact nickel underplated

**B**—Gold flash on mating end, tin on termination end, with entire contact nickel underplated

**Related Product Data:**

**Contact Arrangements**—page 40

**Performance Characteristics**—page 41

**Application Tooling**—pages 121-123

**Mateable Connectors:**

**HDP**—pages 90-97

**HD-20 Board Mount**—pages 54-71, 78-85, 87-89

**Mating Hardware**—pages 146-150, 153, 155

**Mating/Panel Mounting**—page 42

**Receptacle**

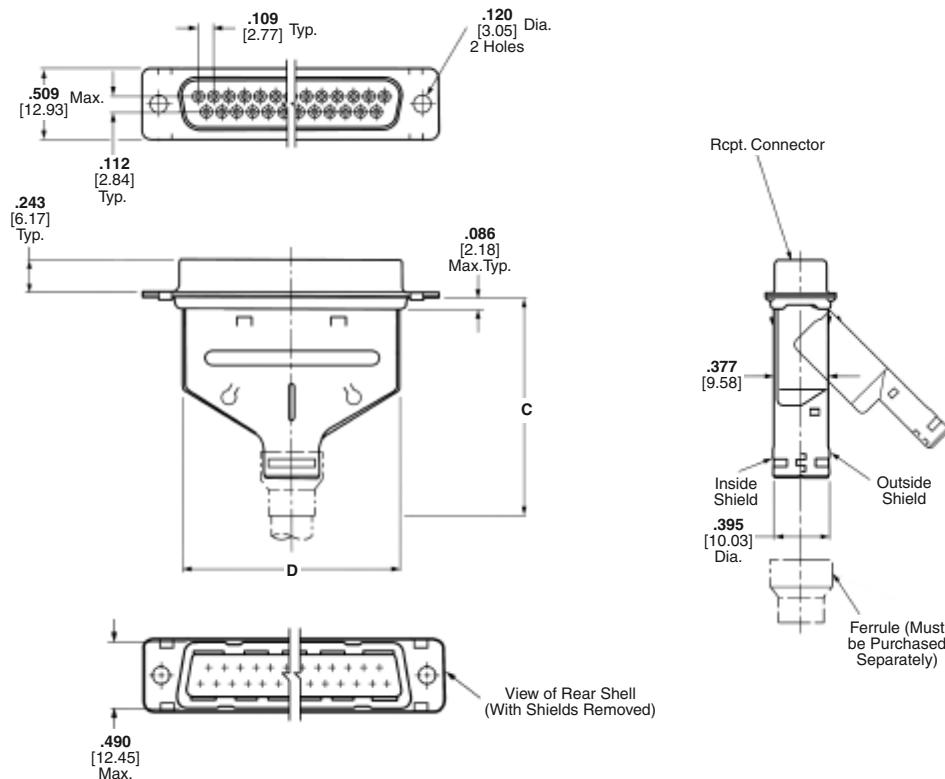

**Technical Documents:**

**Product Specifications**—

108-40011

108-40030

**Application Specifications**—

114-40002

114-40003

114-40006

**Instruction Sheet**—408-9010

**Note:** Instruction Sheets for TE Tooling are packaged with the tooling. For additional information call the Tooling Assistance Center: **1-800-722-1111**.

| Shell Size | No. of Contact Pos. | Dimensions     |                | Recommended Cable Outer Dia. Range | Max. Inner Cable Bundle Dia.† | Contact Finish (Plating Code) | Connector Part Numbers  |  |   |
|------------|---------------------|----------------|----------------|------------------------------------|-------------------------------|-------------------------------|---|--|---|
|            |                     |                |                |                                    |                               |                               | Contact I.D. No. 1 for 30-26 AWG [0.05-0.15mm <sup>2</sup> ] Wire | Contact I.D. No. 2 for 26-22 AWG [0.15-0.4mm <sup>2</sup> ] Wire | Contact I.D. No. 3 for 22-20 AWG [0.4-0.6mm <sup>2</sup> ] Wire |
|            |                     |                |                |                                    |                               |                               | Receptacle  | Receptacle   | Receptacle  |
| 1          | 9                   | 1.520<br>38.61 | .678<br>17.22  | .165-.455<br>4.19-11.56            | .350<br>8.89                  | A                             | —   | 747516-7   | 747516-8  |
|            |                     |                |                |                                    |                               |                               | —   | 747516-9   | —   |
| 2          | 15                  | 1.520<br>38.61 | 1.002<br>25.45 | .165-.455<br>4.19-11.56            | .350<br>8.89                  | A                             | —   | 747532-7   | —   |
|            |                     |                |                |                                    |                               |                               | —   | 747532-8   | —   |
| 3          | 25                  | 1.520<br>38.61 | 1.550<br>39.37 | .165-.455<br>4.19-11.56            | .350<br>8.89                  | A                             | —   | 747548-8   | —   |
|            |                     |                |                |                                    |                               |                               | —   | 747548-9   | —   |
| 4          | 37                  | 1.867<br>47.42 | 2.205<br>56.01 | .338-.562<br>8.59-14.28            | .450<br>11.43                 | B                             | 747564-8  | 747564-9   | —   |
|            |                     |                |                |                                    |                               |                               | —   | —  | —   |

**Note:** Components of the kits are shipped unassembled and bulk-packaged in quantities of 100 pieces.

†Maximum cable diameter after jacket and braid removed.

**Note:** All part numbers are RoHS compliant.



## HDE-20 Shielding Hardware Enclosure Kits



**Each kit contains:**

- Connector
- Inner shield
- Outer shield
- Enclosure
- Two jackscrews

Ferrules must be purchased separately.

**Material and Finish:**

**Connector Shell**—Steel, tin plated

**Connector Insert**—94V-0 rated thermoplastic, black

**Shield**—Steel, tin plated

**Enclosure**—PVC, black

**Jackscrews**—Zinc alloy

**Contacts**—Phosphor bronze

**Contact Finish**—Duplex plated:

**A**—.000030 [0.00076] gold on mating end, tin on termination end, with entire contact nickel underplated

**B**—Gold flash on mating end, tin on termination end, with entire contact nickel underplated

**Related Product Data:**

**Contact Arrangements**—page 40

**Performance Characteristics**—page 41

**Application Tooling**—pages 121-123

**Mateable Connectors:**

**HDP**—pages 90-97

**HD-20 Board Mount**—pages 54-71, 78-85, 87-89

**Mating Hardware**—pages 146-150, 153, 155

**Mating/Panel Mounting**—page 42

**Plug**

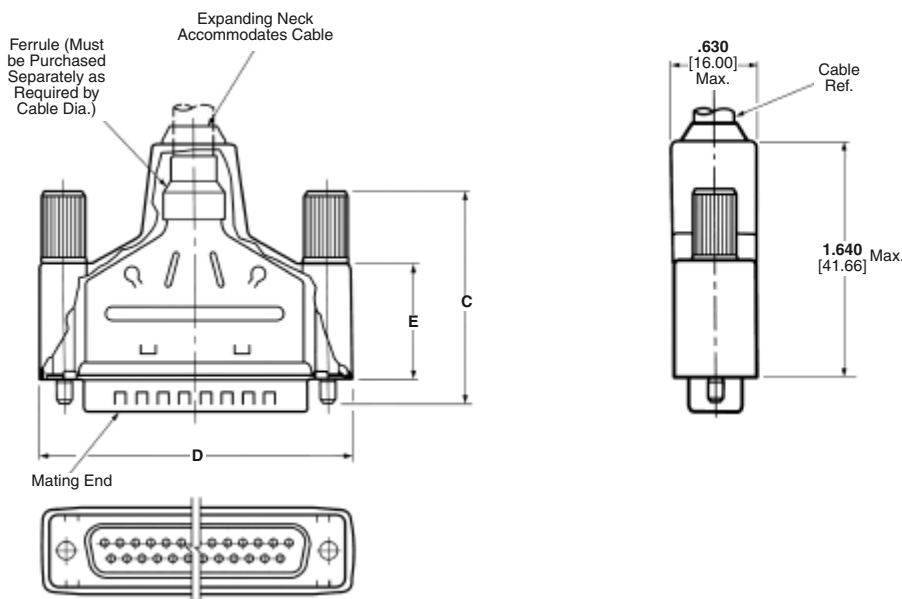

**Technical Documents:**

**Product Specifications**—

- 108-40011
- 108-40030

**Application Specifications**—

- 114-40002
- 114-40003
- 114-40006
- 114-40008

**Instruction Sheet**—408-9172

**Note:** Instruction Sheets for TE Tooling are packaged with the tooling. For additional information call the Tooling Assistance Center: **1-800-722-1111**.

| Shell Size | No. of Contact Pos. | Dimensions     |                |               | Recommended Cable Outer Dia. Range | Max. Inner Cable Bundle Dia.† | Contact Finish (Plating Code) | Kit Part Numbers   |   |  | Shielding Enclosure Expansion Tool |          |
|------------|---------------------|----------------|----------------|---------------|------------------------------------|-------------------------------|-------------------------------|--|---|--|------------------------------------|----------|
|            |                     | C              | D              | E             |                                    |                               |                               | Contact I.D. No. 1 for 30-26 AWG [0.05-0.15mm <sup>2</sup> ] | Contact I.D. No. 2 for 26-22 AWG [0.15-0.4mm <sup>2</sup> ] | Contact I.D. No. 3 for 22-20 AWG [0.4-0.6mm <sup>2</sup> ] | Cable O.D. (Max.)                  | Part No. |
| 1          | 9                   | 1.640<br>41.66 | 1.355<br>34.42 | .630<br>16.00 | .190-.330<br>4.83-8.38             | .330<br>8.38                  | A                             | —  | 1-747944-5  | —  | .330<br>8.38                       | 58241-4  |
|            |                     |                |                |               |                                    |                               | B                             | —  | 1-747944-6  | —  |                                    |          |
| 2          | 15                  | 1.640<br>41.66 | 1.685<br>42.80 | .630<br>16.00 | .190-.330<br>4.83-8.38             | .330<br>8.38                  | A                             | —  | 1-747946-5  | —  | .450<br>11.43                      | 58241-1  |
|            |                     |                |                |               |                                    |                               | B                             | —  | 1-747946-6  | —  |                                    |          |
| 3          | 25                  | 1.640<br>41.66 | 2.210<br>56.13 | .630<br>16.00 | .217-.435<br>5.51-11.05            | .350<br>8.89                  | A                             | 1-747948-5   | 1-747948-6  | —  | .572<br>14.52                      | 58241-2  |
|            |                     |                |                |               |                                    |                               | B                             | —  | 1-747948-8  | 1-747948-9   |                                    |          |
| 4          | 37                  | 2.010<br>51.05 | 2.865<br>72.77 | .730<br>18.54 | .338-.562<br>8.59-14.28            | .450<br>11.43                 | A                             | 1-747950-4   | 1-747950-5  | —  | .572<br>14.52                      | 58241-2  |
|            |                     |                |                |               |                                    |                               | B                             | —  | 1-747950-6  | —  |                                    |          |

†Maximum cable diameter after jacket and braid removed.

**Note:** All part numbers are RoHS compliant.



## HDE-20 Shielding Hardware Enclosure Kits (Continued)



### Receptacle



**Each kit contains:**

- Connector
- Inner shield
- Outer shield
- Enclosure
- Two jackscrews

Ferrules must be purchased separately.

**Material and Finish:**

**Connector Shell**—Steel, tin plated

**Connector Insert**—94V-0 rated thermoplastic, black

**Shield**—Steel, tin plated

**Enclosure**—PVC, black

**Jackscrews**—Zinc alloy

**Contacts**—Phosphor bronze

**Contact Finish**—Duplex plated:

**A**—.000030 [0.00076] gold on mating end, tin on termination end, with entire contact nickel underplated

**B**—Gold flash on mating end, tin on termination end, with entire contact nickel underplated

**Related Product Data:**

**Contact Arrangements**—page 40

**Performance Characteristics**—page 41

**Application Tooling**—pages 121-123

**Mateable Connectors:**

**HDP**—pages 90-97

**HD-20 Board Mount**—pages 54-71, 78-85, 87-89

**Mating Hardware**—pages 146-150, 153, 155

**Mating/Panel Mounting**—page 42

**Technical Documents:**

**Product Specifications**—

108-40011

108-40030

**Application Specifications**—

114-40002

114-40003

114-40006

114-40008

**Instruction Sheet**—408-9172

**Note:** Instruction Sheets for TE Tooling are packaged with the tooling. For additional information call the Tooling Assistance Center: **1-800-722-1111**.

| Shell Size | No. of Contact Pos. | Dimensions |       |       | Recommended Cable Outer Dia. Range | Max. Inner Cable Bundle Dia.† | Contact Finish (Plating Code) | Kit Part Numbers   |   | Shielding Enclosure Expansion Tool |          |
|------------|---------------------|------------|-------|-------|------------------------------------|-------------------------------|-------------------------------|--|---|------------------------------------|----------|
|            |                     | C          | D     | E     |                                    |                               |                               | Contact I.D. No. 1 for 30-26 AWG [0.05-0.15mm <sup>2</sup> ] | Contact I.D. No. 2 for 26-22 AWG [0.15-0.4mm <sup>2</sup> ] | Cable O.D. (Max.)                  | Part No. |
|            |                     |            |       |       |                                    |                               |                               | Receptacle   | Receptacle  |                                    |          |
| 1          | 9                   | 1.640      | 1.355 | .630  | .190-.330                          | .330                          | A                             | 1-747943-5   | 1-747943-6  | .330                               | 58241-4  |
|            |                     | 41.66      | 34.42 | 16.00 |                                    |                               |                               | 4.83-8.38  | 8.38  |                                    |          |
| 2          | 15                  | 1.640      | 1.685 | .630  | .190-.330                          | .330                          | A                             | 1-747945-5   | —   | .330                               | 58241-1  |
|            |                     | 41.66      | 42.80 | 16.00 |                                    |                               |                               | 4.83-8.38  | 8.38  |                                    |          |
| 3          | 25                  | 1.640      | 2.210 | .630  | .217-.435                          | .350                          | A                             | 1-747947-5   | 1-747947-6  | .450                               | 58241-1  |
|            |                     | 41.66      | 56.13 | 16.00 |                                    |                               |                               | 5.51-11.05   | 8.89  |                                    |          |
| 4          | 37                  | 2.010      | 2.865 | .730  | .338-.562                          | .450                          | A                             | —  | —   | .572                               | 58241-2  |
|            |                     | 51.05      | 72.77 | 18.54 |                                    |                               |                               | 8.59-14.28   | 11.43   |                                    |          |

†Maximum cable diameter after jacket and braid removed.

**Note:** All part numbers are RoHS compliant.

## HDE-20 Crimp Snap-In Contact Connectors

### Ferrules for Shielding Hardware Kits



Stepped



Straight



| Shell Sizes | Style    | L Dim.        | Cable Diameter           | Part Numbers |           |
|-------------|----------|---------------|--------------------------|--------------|-----------|
|             |          |               |                          | Ferrule      | Die Sets* |
| 1-3         | Stepped  | .440<br>11.18 | .165-.190<br>4.19-4.83   | 3-747579-0   | 543424-3  |
| 1-3         | Stepped  | .440<br>11.18 | .190-.217<br>4.83-5.51   | 3-747579-0   | 543424-2  |
| 1-3         | Stepped  | .440<br>11.18 | .217-.246<br>5.51-6.25   | 3-747579-0   | 543424-8  |
| 1-3         | Stepped  | .440<br>11.18 | .246-.284<br>6.25-7.21   | 3-747579-2   | 543424-1  |
| 1-3         | Stepped  | .440<br>11.18 | .284-.324<br>7.21-8.23   | 3-747579-2   | 543424-7  |
| 1-3         | Stepped  | .440<br>11.18 | .324-.375<br>8.23-9.53   | 3-747579-4   | 543424-6  |
| 1-3         | Straight | .440<br>11.18 | .375-.435<br>9.53-11.05  | 2-747579-7   | 543424-5  |
| 1-3         | Straight | .440<br>11.18 | .400-.455<br>10.16-11.56 | 3-747579-6   | 543424-4  |
| 4           | Stepped  | .625<br>15.88 | .230-.265<br>5.84-6.73   | 2-747580-4   | 543425-2  |
| 4           | Stepped  | .625<br>15.88 | .338-.385<br>8.59-9.78   | 2-747580-3   | 543425-1  |
| 4           | Stepped  | .625<br>15.88 | .375-.432<br>9.53-10.97  | 2-747580-1   | 58238-1   |
| 4           | Stepped  | .625<br>15.88 | .422-.490<br>10.72-12.45 | 3-747580-1   | 58237-2   |
| 4           | Straight | .625<br>15.88 | .480-.562<br>12.19-14.28 | 2-747580-2   | 58237-1   |

\*Die sets used with Hand Crimping Tool Part No. 543344-1 or Pneumatic Bench Tool Part No. 312522-3 equipped with Die Set Holder Part No. 58449-1.

### Material and Finish:

Steel (annealed), tin plated

### Related Product Data:

Shielding Hardware and Enclosure Kits—pages 116-119

### Technical Documents:

#### Instruction Sheets—

408-9242  
408-9243  
408-9507  
408-9508

**Note:** Instruction Sheets for TE Tooling are packaged with the tooling. For additional information call the Tooling Assistance Center: **1-800-722-1111**.

### Application Tooling for Shielding Hardware Kits



Hand Crimping Tool  
No. 543344-1  
(Requires Die Sets, see table above.)



Shielding Enclosure Expansion Tools  
Part No. 58241-1 (.450 [11.43])†  
58241-2 (.572 [14.53])†  
58241-4 (.330 [8.38])†  
†Maximum Cable Diameter  
(Instruction Sheet—408-9507)

Pneumatic Bench Tool  
No. 312522-3  
(Requires Die Set Holder  
No. 58449-1.)



**Note:** All part numbers are RoHS compliant.

## HDE-20 Contacts, Precision Formed

### Material and Finish:

Phosphor bronze, duplex plated as follows:

**A**—Duplex plated .000030 [0.00076] gold on mating end, tin on termination end, with entire contact nickel underplated

**B**—Gold flash on mating end, tin on termination end, with entire contact nickel underplated

### Interchangeable Contacts, Crimp Snap-In



Pin



Socket

### Related Product Data:

**Performance Characteristics**—page 41

**Connectors used with:**  
HDE—pages 112-119

### Technical Documents:

**Product Specifications**—  
108-40011  
108-40030

**Application Specifications**—  
114-40002  
114-40003  
114-40006  
114-40008

**Instruction Sheet**—408-6738

**Note:** Instruction Sheets for TE Tooling are packaged with the tooling. For additional information call the Tooling Assistance Center: **1-800-722-1111**.

| Wire Size Range<br>AWG<br>mm <sup>2</sup> | Code* | Insulation Diameter |          | Contact Finish<br>(Plating Code) | Contact Part Numbers |                   |
|---|-------|---------------------|----------|----------------------------------|----------------------|-------------------|
|   |       | Single Wire         | Two Wire |                                  | Pin Strip Form       | Socket Strip Form |
| 26-22<br>0.15-0.4                         | 4     | .054                | .039     | A                                | —                    | 1-745269-1        |
|   |       | 1.37                | 0.99     | B                                | 1-745266-0           | 1-745269-0        |
| 22-18<br>0.4-0.8                          | 3     | .075                | .054     | A                                | 1-745267-0           | 1-745270-1        |
|   |       | 1.91                | 1.37     | B                                | —                    | 1-745270-0        |

\* A Code indicating accepted wire size range is stamped inside insulation crimp barrel of each contact.

**Notes:** 1. Extraction Tool No. 91232-1 is used to remove pin and socket contacts.  
2. Strip form contacts shipped 10,000 pieces/reel.

**Note:** All part numbers are RoHS compliant.

## HDE-20 Application Tooling

### Hand Tools with Modular Heads

#### Technical Documents:

##### Instruction Sheets—

408-6790

408-9414

408-6789

**Note:** Instruction Sheets for TE Tooling are packaged with the tooling. For additional information call the Tooling Assistance Hotline: **1-800-722-1111**.

A modular interchangeable head provides versatility to these tools. Along with the head used to terminate Subminiature D connectors, heads are available to terminate other TE product lines.

The head used to terminate the Subminiature D, HDE connectors can be used with a manual pistol grip tool, an air pistol grip tool and a bench mount power assembly. These tools terminate one unstripped wire per cycle and index the connector to the next terminating position. The head rotates to permit optimum access to the wiring area.

### Manual Pistol Grip Tool



**Handle and Head Tool Assembly No. 608868-1**  
**Handle No. 58074-1**  
**Head Assembly No. 58063-2**

This tool is manually actuated, using modular heads.

### Air Pistol Grip Tool



**Handle No. 58075-1**  
**Head Assembly No. 58063-2**

Air actuated, utilizing modular heads.

### Bench Mounted Tools with Modular Heads

#### Bench Mount Pneumatic Power Assembly



**Bench Assembly No. 58338-1**  
**Head Assembly No. 58063-2**

This tool is air actuated with either a foot or knee switch.

#### Bench Mount Electric Power Assembly



**Head Assembly No. 58063-2**

This tool electrically powered and actuated by a foot switch.

**Note:** All part numbers are RoHS compliant.

## HDE-20 Application Tooling (Continued)

### Product Facts

- Low applied costs
- Automatic termination of jacketed cable
- Automatic continuity check and shorts test
- Single- or double-ended assemblies
- Microprocessor controlled with touch input screen
- Stored program capability
- Selective termination of connector positions
- Rapid tooling changeover for different connector types
- Handles a variety of TE insulation-displacement connectors
- Terminates both multicolor and single-color wires
- Remote programming capability
- Straight or right-angle wire dress
- Control Module  
852423-1 120 VAC



### CHAMPOMATOR 3A Terminating Machine

This machine is the high-productivity way to terminate multiconductor, jacketed cable with a variety of TE connectors having insulation displacement contacts. It automatically sorts the wires, and terminates them in a programmed sequence. The sequence may use all or some of the connector contacts, such as for various RS-232 wiring patterns.

All cable assemblies are tested for continuity and shorts.

The machine is microprocessor controlled, and programmed by a touch input screen. The easy programming simplifies the process and reduces training requirements. The machine's internal storage capability can retain up to 50 cable assemblies, which can be easily retrieved by number or name. Production monitoring and diagnostics can also be accessed through the touch screen.

Contact TE for the tooling required for your specific applications.

### Technical Documents:

#### Instruction Sheets

408-7777 Manual Arbor Tool

**Note:** Instruction Sheets for TE Tooling are packaged with the tooling. For additional information call the Tooling Assistance Center: **1-800-722-1111**.



Control Module  
No. 852423-1

CHAMPOMATOR  
2.5 Machine  
No. 354786-4

### CHAMPOMATOR 2.5 Terminating Machine

This is a compact, semi-automatic bench machine. It is microprocessor controlled, and programmed using a membrane switch keyboard. The potential machine rate is one pair of wires per second. Contact TE for the tooling required for your specific applications.

The CHAMPOMATOR Model 2.5 Bench Terminating Machine—**Part No. 354786-4** is used in conjunction with Control Module—**Part No. 852423-1**.

Contact TE for application specific requirements.

### Manual Arbor Tool



Arbor Tool No. 91085-2  
Applicators:

Wire O.D. .041-.060 [1.04-1.52]—No. 543157-1 (tool mount),  
543426-1 (termination tool)

Wire O.D. .040 [1.02] and smaller—No. 543157-1 (tool mount),  
543426-2 (termination tool)

**Note:** All part numbers are RoHS compliant.

### Manual Arbor Tool

The arbor tool with applicator is used to terminate jacketed cable. Wires are neatly routed and trimmed to length with the cable jacket close to the connector. 400 to 800 terminated wires per hour are typical.

## Subminiature D Connectors HDF-20 for Flat Ribbon Cable

### Product Facts

- Available in all 5 standard shell sizes
- Visual inspection of termination possible
- Fluted cover provides positive alignment of cable prior to termination
- Wide range of application tooling
- Patented insulation displacement contact latches into the connector cover
- Contact design provides a “gas-tight” termination
- Contacts accept 28 AWG [0.08mm<sup>2</sup>] solid and stranded, and 26 AWG [0.15mm<sup>2</sup>] solid and stranded round conductor flat ribbon cable on .050 [1.27] centers
- Qualified to Battelle Level III environment
- Recognized under the Component Program of Underwriters Laboratories Inc., File No. E28476 
- Certified by Canadian Standards Association, File No. LR 7189 
- Listed and complies with UL 1863, Communication Circuit Accessories File No. E81956 

### Plug — Low Profile Metal Shell



### Receptacle — Low Profile Metal Shell



| No. of Pos. & (Shell Size) | Cable Stabilizer Part No. | Plug Part Nos.               |                            | Receptacle Part Nos.         |                            |
|----------------------------|---------------------------|------------------------------|----------------------------|------------------------------|----------------------------|
|                            |                           | With Standard Mounting Holes | With 4-40 Threaded Inserts | With Standard Mounting Holes | With 4-40 Threaded Inserts |
| 9 (1)                      | 747275-4                  | 1658613-4                    | 1658608-4                  | 1658612-4                    | 1658610-4                  |
| 15 (2)                     | 747275-3                  | 1658613-3                    | 1658608-3                  | 1658612-3                    | 1658610-3                  |
| 25 (3)                     | 747275-2                  | 1658613-2                    | 1658608-2                  | 1658612-2                    | 1658610-2                  |
| 37 (4)                     | 747275-1                  | 1658613-1                    | 1658608-1                  | 1658612-1                    | 1658610-1                  |
| 50 (5)                     | 746785-1                  | —                            | 1658607-1                  | —                            | 1658606-1                  |

**Note:** All assemblies are supplied with housing and cover pre-assembled. Optional cable stabilizer must be ordered separately.

### Material

**Front Shell**—Steel, tin or tin plated

**Housing, Cover & Cable Stabilizer**—Thermoplastic, 94V-0, black

**Threaded Inserts**—Brass, unplated

**Contacts**—Phosphor bronze, duplex plated .000030 [0.00076] min. gold on mating end, .000100-.000200 [0.00254-0.00508] bright tin on termination end with entire contact underplated .000050 [0.00127] min. nickel

### Related Product Data

**Contact Arrangement**—page 40

**Performance Characteristics**—page 41

### Mateable Receptacles:

**HDF-20 Metal-Shell**—page 124

**HDE**—pages 110-121 (Sizes 1-4 only)

**HDP**—pages 90-109

**HD-20 Board Mount**—pages 54-71, 78-85, 87-89

**Mating/Panel Mounting**—page 126

**Ribbon Cable**—page 125

### Accessories:

**Commoning Strip**—page 146

**Mating Hardware**—pages 146-150, 153 & 154

**Application Tooling**—page 127

### Technical Documents

**Product Specification**—108-40012

**Note:** All part numbers are RoHS compliant.



## HDF-20 Low Profile All-Plastic Connectors (for Round Conductor Flat Ribbon Cable)

### Material and Finish

#### Housing, Cover & Cable Stabilizer

—Black thermoplastic, 94V-0 rated

#### Threaded Inserts

—Brass, unplated  
**Pin Contacts**—Phosphor bronze, duplex plated .000030 [0.00076] gold on mating end, .000100-.000200 [0.00254-0.00508] bright tin on termination end, with entire contact underplated .000050 [0.00127] nickel

### Related Product Data

**Contact Arrangement**—page 40

**Performance Characteristics**—page 41

#### Mateable Receptacles:

**HDF-20 All-Plastic**—page 124

**HD-20 Board Mount**—pages 54-71, 78-85, 87-89

**HDE All-Plastic**—pages 147, 148

**Mating/Panel Mounting**—page 126

**Ribbon Cable**—page 125

#### Accessories:

**Mating Hardware**—pages 146-150, 153, 155

**Application Tooling**—page 127

### Technical Documents

#### Product Specifications—

108-40012 HDF-20 Low Profile Connectors

### Plug Assemblies



Housing and Covers are Preassembled; Cable Stabilizer is Separate.

### Receptacle Assemblies



Housing and Covers are Preassembled; Cable Stabilizer is Separate.

| No. of Contact Pos. & (Shell Size) | Optional Cable Stabilizer Part No. | Plug Assembly Part No.       |                       | Receptacle Assembly Part No. |                       |
|------------------------------------|------------------------------------|------------------------------|-----------------------|------------------------------|-----------------------|
|                                    |                                    | With Standard Mounting Holes | With Threaded Inserts | With Standard Mounting Holes | With Threaded Inserts |
| 9 (1)                              | 747275-4                           | 1658615-4                    | 1658611-4             | 1658614-4                    | 1658609-4             |
| 15 (2)                             | 747275-3                           | 1658615-3                    | 1658611-3             | 1658614-3                    | 1658609-3             |
| 25 (3)                             | 747275-2                           | 1658615-2                    | 1658611-2             | 1658614-2                    | 1658609-2             |
| 37 (4)                             | 747275-1                           | 1658615-1                    | —                     | 1658614-1                    | 1658609-1             |

**Note:** All assemblies are supplied with housing and cover pre-assembled. Optional cable stabilizer must be ordered separately.

### Ribbon Cable Parameters

| No. of Conductors | 28 AWG [0.08mm <sup>2</sup> ] Part No. |                  | 26 AWG [0.15mm <sup>2</sup> ] Part No. |
|-------------------|--|------------------|--|
|                   | Length Per Reel                        |                  | Length Per Reel                        |
|                   | 100 Ft. [30.5m]                        | 500 Ft. [152.4m] | 500 Ft. [152.4m]                       |
| 9                 | 1-57040-2                              | 1-971111-2       | 57034-2                                |
| 15                | 1-57040-5                              | 1-971111-5       | 57034-5                                |
| 25                | 57040-2                                | 971111-2         | 57034-9                                |
| 37                | 1-57040-8                              | 1-971111-8       | 1-57034-3                              |
| 50                | 57040-6                                | 971111-6         | 1-57034-5                              |

**Note:** All part numbers are RoHS compliant.

## HDF-20 Plugs/Receptacles Mating and Panel Mounting Specifications

### Plug/Receptacle Mating



The .265/.256 [6.73/6.50] dimensions are required to assure full mating of connector halves. These dimensions must be taken into consideration when determining the method of mounting, panel thickness, etc.

### Panel Mounting

Plugs and receptacles can be mounted to a panel from either the front or rear, using a variety of accessory hardware. Typical examples are shown below.



Typical Front-Panel Mounted HDF-20 Plug



Typical Rear-Panel Mounted HDF-20 Plug

### Panel Cutouts

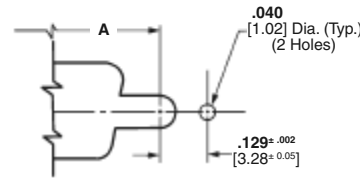

Cutout for Rear Mount and Short Latching Blocks

| Shell Size (Pos.) | Mounting Method Front/Rear Panel | Dimensions     |                |                |                |               |              |       |       |              |
|-------------------|----------------------------------|----------------|----------------|----------------|----------------|---------------|--------------|-------|-------|--------------|
|                   |                                  | A              | B              | C              | D              | E             | F            | H*    | J*    | K            |
| 1 (9)             | Front                            | .984<br>24.99  | .492<br>12.50  | .874<br>22.20  | .437<br>11.10  | .513<br>13.03 | .257<br>6.53 | —     | —     | .083<br>2.11 |
|                   | Rear                             | .984<br>24.99  | .492<br>12.50  | .806<br>20.47  | .403<br>10.24  | .449<br>11.41 | .225<br>5.72 | 13.97 | 19.05 | .132<br>3.35 |
| 2 (15)            | Front                            | 1.312<br>33.33 | .656<br>16.66  | 1.202<br>30.53 | .601<br>15.27  | .513<br>13.03 | .257<br>6.53 | —     | —     | .083<br>2.11 |
|                   | Rear                             | 1.312<br>33.33 | .656<br>16.66  | 1.134<br>28.80 | .567<br>14.40  | .449<br>11.41 | .225<br>5.72 | 18.54 | 19.05 | .132<br>3.35 |
| 3 (25)            | Front                            | 1.852<br>47.04 | .926<br>23.52  | 1.743<br>44.27 | .872<br>22.15  | .513<br>13.03 | .257<br>6.53 | —     | —     | .083<br>2.11 |
|                   | Rear                             | 1.852<br>47.04 | .926<br>23.52  | 1.674<br>42.52 | .842<br>21.39  | .449<br>11.41 | .225<br>5.72 | 32.39 | 19.05 | .132<br>3.35 |
| 4 (37)            | Front                            | 2.500<br>63.50 | 1.250<br>31.75 | 2.391<br>60.73 | 1.196<br>30.38 | .513<br>13.03 | .257<br>6.53 | —     | —     | .083<br>2.11 |
|                   | Rear                             | 2.500<br>63.50 | 1.250<br>31.75 | 2.326<br>59.08 | 1.163<br>29.54 | .449<br>11.41 | .225<br>5.72 | 46.05 | 16.13 | .132<br>3.35 |
| 5 (50)            | Front                            | 2.406<br>61.11 | 1.203<br>30.56 | 2.297<br>58.34 | 1.149<br>29.19 | .623<br>15.82 | .312<br>7.93 | —     | —     | .083<br>2.11 |
|                   | Rear                             | 2.406<br>61.11 | 1.203<br>30.56 | 2.218<br>56.34 | 1.109<br>28.17 | .555<br>14.10 | .278<br>7.06 | 44.52 | 19.05 | .132<br>3.35 |

\*Panel cutout configuration with H and J dimensions provides clearance for mounting connectors with cable clamps.

---

## HDF-20 Application Tooling

---

### Application Tooling



**Hand Tool Kit No. 768340-1**



Consists of a hand tool frame, a universal base assembly, a bench mount kit, and connector-specific tooling for AMP-LATCH Standard and Novo Receptacles, Card-Edge Connectors, and AMPLIMITE HDF-20 Connectors.

**Note:** For 50-position HDF connectors, you must also order Connector-Specific Kit No. 768350-1.

**Note:** All part numbers are RoHS compliant.

## HD-20 Solder Cup Connectors

### Product Facts

- Preloaded duplex-plated solder cup contacts
- Shell finish in choice of standard zinc or tin
- Two-piece 94V-0 rated plastic insert
- Anti-solderwicking contact design
- Intermateable with other subminiature D connectors
- Available in 9, 15, 25 and 37 position (shell sizes 1-4) plugs and receptacles
- Easy application without special application tools
- Shields offer full EMI shielding and ESD insulation
- Crimped shield termination for low impedance
- Shield crimp provides strain relief
- Shields may be post molded or covered with enclosures
- Recognized under the Component Program of Underwriters Laboratories, Inc.,  File No. E28476
- Listed under Underwriters Laboratories Inc., connectors for use in data, signal, control & Power Applications — components,  File No. E127344
- Certified by Canadian Standards Association,  File No. LR 97981

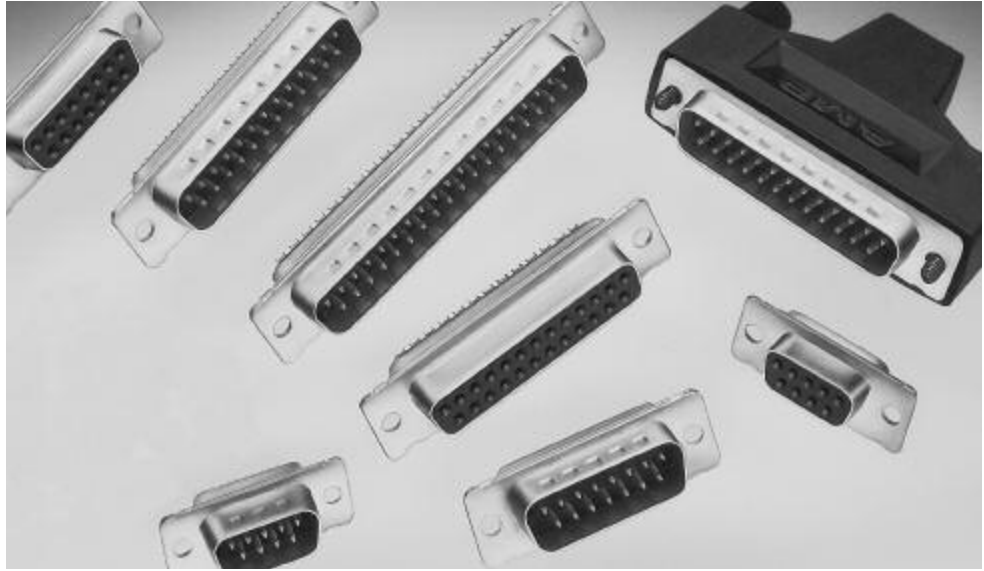

**HD-20 Solder Cup Connectors** (Continued)



**Plug**

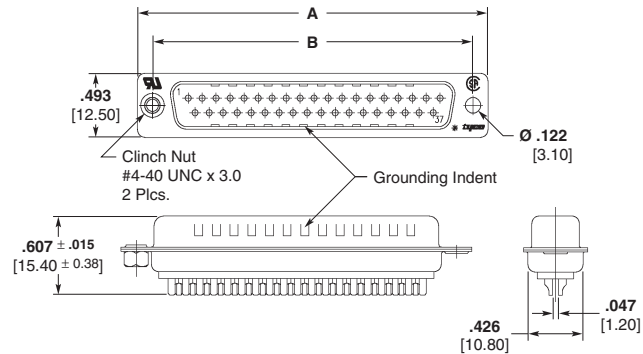

**Material and Finish:**

**Shell**—Steel, tin or zinc plated

**Insert**—94V-0 rated thermoplastic, black

**Contacts**—Phosphor bronze; duplex plated with gold flash on mating end, tin on solder cup, with entire contact nickel underplated

**Related Product Data:**

**Mateable Connectors:**

**HDE**—pages 110-119

**HDF**—pages 124-126

**HDP**—pages 90-101

**HD-20 Solder Cup**—pages 128-130

**HD-20 Board Mount**—pages 54-71, 78-85, 87-89

**Cable Clamps**—pages 132, 133, 135-137, 140, 141, 144, 145

**Mating Hardware**—pages 146-150, 151-154

**Technical Documents:**

**Product Specification**

108-40031

**Instruction Sheet**

408-9193

**Receptacle**

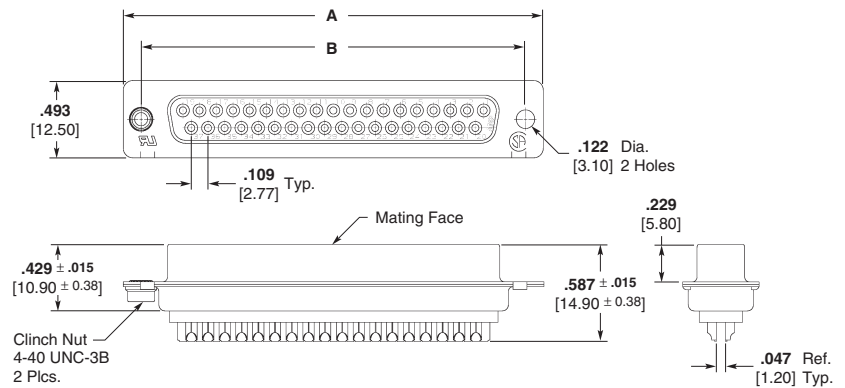

| Shell Size | No. of Contact Positions | Dimensions |       | Plug Part Numbers |                   | Receptacle Part Numbers |                   |
|------------|--------------------------|------------|-------|-------------------|-------------------|-------------------------|-------------------|
|            |                          | A          | B     | Tin Plated Shell  | Zinc Plated Shell | Tin Plated Shell        | Zinc Plated Shell |
| 1          | 9                        | 1.210      | .984  | 5-747904-2        | 5-747904-2        | 5-747905-2              | 5-747905-2        |
|            |                          | 30.80      | 24.99 |                   |                   |                         |                   |
| 2          | 15                       | 1.544      | 1.313 | 5-747908-2        | 5-747908-2        | 5-747909-2              | 5-747909-2        |
|            |                          | 39.20      | 33.32 |                   |                   |                         |                   |
| 3          | 25                       | 2.089      | 1.853 | 5-747912-2        | 5-747912-2        | 5-747913-2              | 5-747913-2        |
|            |                          | 53.01      | 47.04 |                   |                   |                         |                   |
| 4          | 37                       | 2.734      | 2.502 | 5-747916-2        | 5-747916-2        | 5-747917-2              | 747917-4          |
|            |                          | 69.40      | 63.50 |                   |                   |                         |                   |

**Note:** All part numbers are RoHS compliant.

## HD-20 Solder Cup Shielding Hardware Enclosure Kits

### Plug and Receptacles



**Each kit contains**

- Connector with preloaded, nonremovable contacts
- Shield
- Enclosure
- Two jackscrews

**Material and Finish:**

**Connector Shell**—Steel, tin plated

**Connector Insert**—94V-0 rated thermoplastic, black

**Shields**—Steel, tin plated

**Enclosure**—PVC, black

**Jackscrews**—Brass, zinc coated

**Contacts**—Phosphor bronze; duplex plated with gold flash on mating end, tin on solder cup, with entire contact nickel underplated

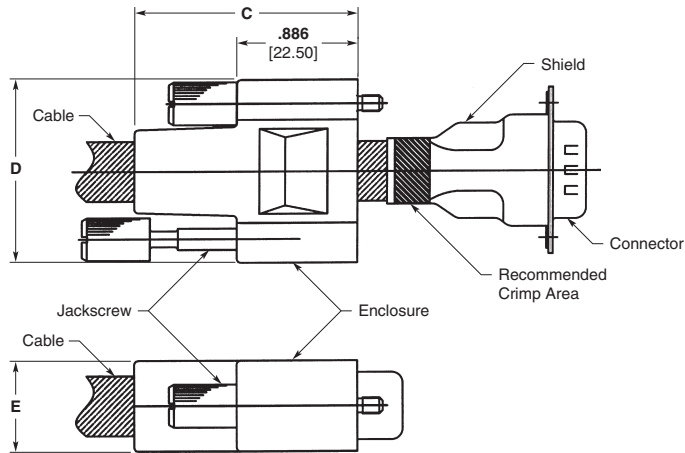

| Shell Size | No. of Contact Positions | Dimensions    |               |               | Cable Insulation Diameter | Kit Part Numbers |            | Shielding Enclosure Expansion Tool |             |
|------------|--------------------------|---------------|---------------|---------------|---------------------------|------------------|------------|------------------------------------|-------------|
|            |                          | C             | D             | E             |                           | Plug             | Receptacle | Cable O.D. (Max.)                  | Part Number |
| 1          | 9                        | 1.64<br>41.67 | 1.33<br>33.74 | .659<br>16.74 | .217-.270<br>5.51-6.86    | 1571650-4        | 1571654-4  | .355<br>9.02                       | 58241-4     |
|            |                          |               |               |               | .270-.324<br>6.86-8.23    | 1571650-5        | 1571654-5  |                                    |             |
|            |                          |               |               |               | .324-.385<br>8.23-9.78    | 1571650-6        | 1571654-6  |                                    |             |
| 2          | 15                       | 1.64<br>41.67 | 1.65<br>41.86 | .659<br>16.74 | .217-.270<br>5.51-6.86    | 1571651-4        | 1571655-4  | .355<br>9.02                       | 58241-4     |
|            |                          |               |               |               | .270-.324<br>6.86-8.23    | 1571651-5        | 1571655-5  |                                    |             |
|            |                          |               |               |               | .324-.385<br>8.23-9.78    | 1571651-6        | 1571655-6  |                                    |             |
| 3          | 25                       | 1.64<br>41.67 | 2.20<br>55.86 | .659<br>16.74 | .217-.270<br>5.51-6.86    | 1571652-4        | 1571656-4  | .465<br>11.56                      | 58241-1     |
|            |                          |               |               |               | .270-.324<br>6.86-8.23    | 1571652-5        | 1571656-5  |                                    |             |
|            |                          |               |               |               | .324-.385<br>8.23-9.78    | 1571652-6        | 1571656-6  |                                    |             |
| 4          | 37                       | 2.35<br>59.67 | 2.82<br>71.63 | .659<br>16.74 | .455-.480<br>11.58-12.19  | 1571653-2        | 1571657-2  | .562<br>14.28                      | 58241-2     |

**Note:** Components of the kits are shipped unassembled and bulk-packaged in quantities of 100 pieces.

### HD-20 Solder Cup Shielding Hardware Crimping Tool

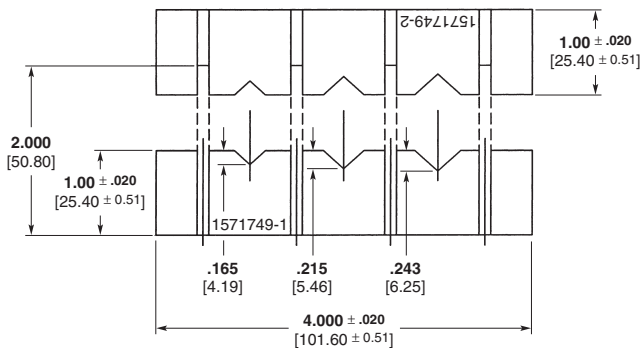

**Assembled Tooling: Part Number 1571750-1**  
**Individual Tools (for customer fabrication):**  
**1571749-1 & 1571749-2**

**Note:** All part numbers are RoHS compliant.



## Accessories

Numerous accessories are available for strain relief and cable clamping, shielding, connector-to-connector mating, connector-to-connector pc board mounting, and keying. These accessories are illustrated and tabled on the following pages.

To help discern the accessories available for a particular connector type, refer to the Product Selection Guide at the beginning of the connector section. Also, the connector the accessory is used with is listed under the Related Product Data heading next to the accessory listing.



### Section Contents

#### Unshielded Cable Clamps

|  |          |
|--|----------|
| Universal Cable Clamps for Jacketed Cable .....    | 132      |
| One-Piece, All-Plastic Cable Clamp .....           | 133, 134 |
| Straight/90° Low Profile Cable Clamps .....        | 135      |
| Slide-On Back Covers .....                         | 136      |
| Box and Lid, Straight/90° Exit .....               | 137      |
| Clam Shell, Straight/45° .....                     | 138      |
| Straight Exit, Dataphone .....                     | 139      |
| Straight Exit for Jacketed Cable (Two-Piece) ..... | 139      |
| Straight/90° Exit .....                            | 140      |

#### Shielded Cable Clamps

|  |         |
|--|---------|
| Straight Exit RFI/EMI Shields for Jacketed Cable (HDE, HDP) .....              | 141     |
| Straight/90° Exit RFI/EMI Die Cast Shields for Jacketed Cable (HDE, HDP) ..... | 142     |
| Crimp and Split-Ring Ferrules .....  | 143-145 |

#### Hardware

|  |          |
|--|----------|
| Commoning Strip .....  | 146      |
| Male Screw Retainers for Metal-Shell Connectors (HDE, HDP) .....                   | 146      |
| Male Screw Retainers for All-Plastic Connectors (HDE) ..                           | 147      |
| Male Screw Retainers for Metal-Shell and All-Plastic Connectors (HDF) .....        | 147      |
| Female Screwlocks for Metal-Shell and All-Plastic Connectors (HDE, HDF, HDP) ..... | 148      |
| Slide Latches .....  | 149, 150 |
| Slide Latch Clips .....  | 151      |
| Locking Post Assemblies .....  | 151      |
| Spring Latches (Two-Piece) .....   | 152      |
| Latching Blocks (HDE, HDF, HDP, HD) .....  | 153, 154 |
| Standoff Bushings .....  | 155      |
| Keying Plug .....  | 155      |
| EMI/RFI Gasket .....   | 155      |

## Unshielded Cable Clamps

### Material and Finish:

**Cable Clamp Housing**—  
Thermoplastic, black

**Cable Clamp Wedge Set**—  
Thermoplastic, black

**4-40 Mounting Screws**—  
Steel, zinc plated

### Related Product Data:

**Connectors used with:**  
**HDE Metal-Shell**—pages 114 & 115  
**HDP Metal-Shell**—pages 90-102

**Other accessory capabilities:**  
**Spring Latches (Two Piece)**—  
page 152

### Technical Documents:

**Instruction Sheet**—408-9238

### Universal Cable Clamps for Jacketed Cable

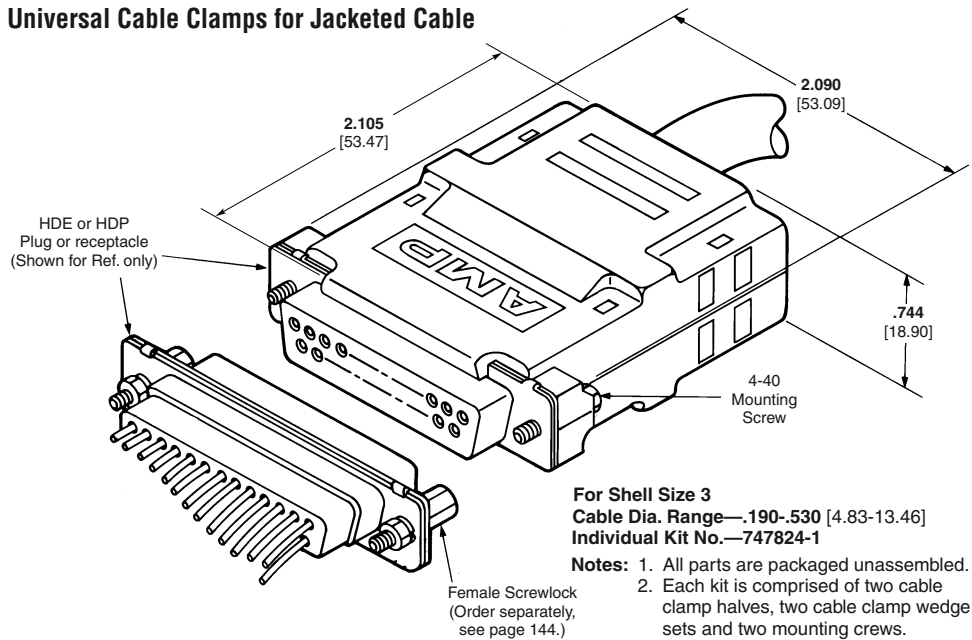

**For Shell Size 3**  
**Cable Dia. Range**—190-530 [4.83-13.46]  
**Individual Kit No.**—747824-1

- Notes:**
1. All parts are packaged unassembled.
  2. Each kit is comprised of two cable clamp halves, two cable clamp wedge sets and two mounting crews.

### Material and Finish:

**Cable Clamp Housing**—  
Thermoplastic, gray

**4-40 Mounting Screws**—  
Steel, zinc plated

**4-40 Housing Screws & Hex Nuts**  
—Steel, zinc plated

### Related Product Data:

**Connectors used with:**  
**HDE All-Plastic**—pages 112 & 113  
**HDE Metal-Shell**—pages 114 & 115  
**HDP Metal-Shell**—pages 90-102

**Other accessory capabilities:**  
**Spring Latches (Two Piece)**—  
page 152

### Technical Documents:

**Instruction Sheet**—408-7555

### Straight/90° Exit

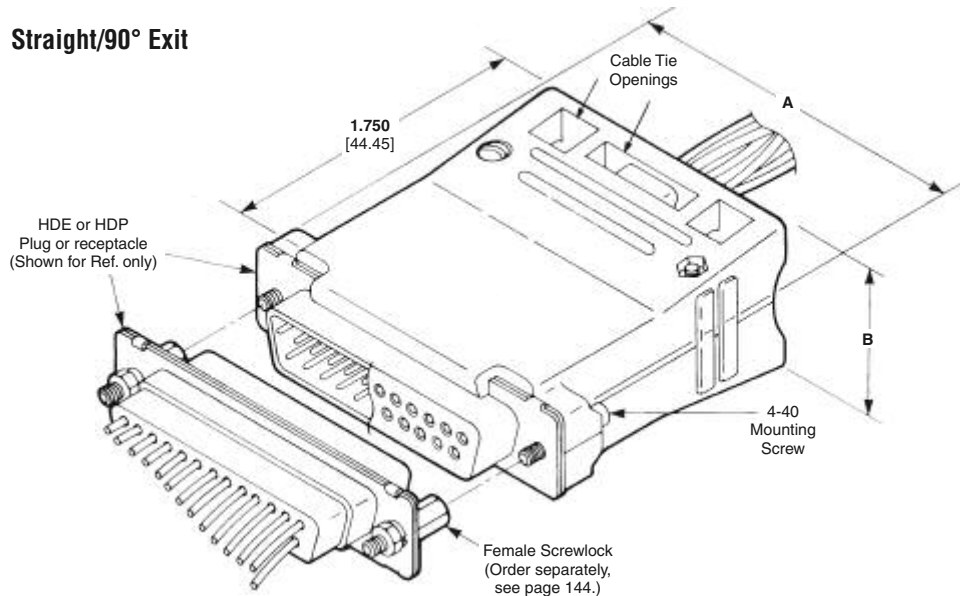

| Shell Size | Dimensions |       | Cable Dia. (Max.) | Cable Clamp Kit No. |
|------------|------------|-------|-------------------|---------------------|
|            | A          | B     |                   | Individual          |
| 2          | 1.550      | .826  | .350              | 5206471-1           |
|            | 39.37      | 20.98 | 8.89              |                     |
| 3          | 2.090      | .826  | .335              | 5206472-1           |
|            |            |       | 8.51              |                     |
|            |            |       | .460              |                     |
| 11.68      | 5745134-1  |       |                   |                     |
| 4          | 2.738      | .826  | .675              | 5745081-1           |
|            |            |       | 17.15             |                     |
| 5          | 2.644      | .938  | .775              | 5745082-1           |
|            |            |       | 19.69             |                     |
| 67.16      | 23.83      | 19.69 |                   |                     |

- Notes:**
1. All parts are packaged unassembled.
  2. Straight or 90° cable exit is achieved by inserting AMP-TY Cable Ties through cable tie openings and clamping the cable to one housing half only.

**Note:** All part numbers are RoHS compliant.

## Unshielded Cable Clamps (Continued)

The TE Quik-Snap Backshell Kit is a one-piece, all-plastic cable clamp kit designed for use with either the AMPLIMITE HDP-20, HDP-22, or HDE, all-plastic or metal-shell connectors.

Kits are available for connector sizes 1, 2, 3, and 4 with a cable exit option of 180° or 120°.

### Each kit contains:

- 1-Hinged, plastic clamp
- 2-Self-tapping screws
- 1-Strain relief clip
- 1-Cable exit gate plug (Used to close unused exit)

(For metal-shell connector applications an optional kit with 2 retainer clips and screws is available.)

### Material and Finish:

- Cover**—Polypropylene, black
- Strain Relief Clip**—Stainless steel
- Retainer Clip**—Stainless steel
- Screws**—Carbon steel, zinc plated
- Cable Gate**—Polypropylene, Black

### Related Product Data:

- Connectors used with:**
- HDP Metal-Shell**—pages 90-102
- HDE All-Plastic**—pages 112 & 113
- HDE Metal-Shell**—pages 114 & 115

### Technical Documents:

- Instruction Sheet**—408-7837

### One-Piece, All-Plastic Cable Clamp for Jacketed Cable, 180°/120° Exit (HDP and HDE) (Quik-Snap)

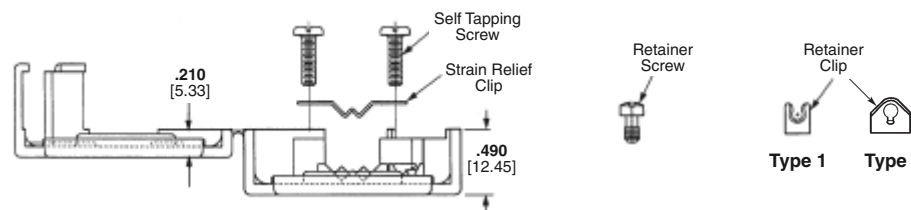
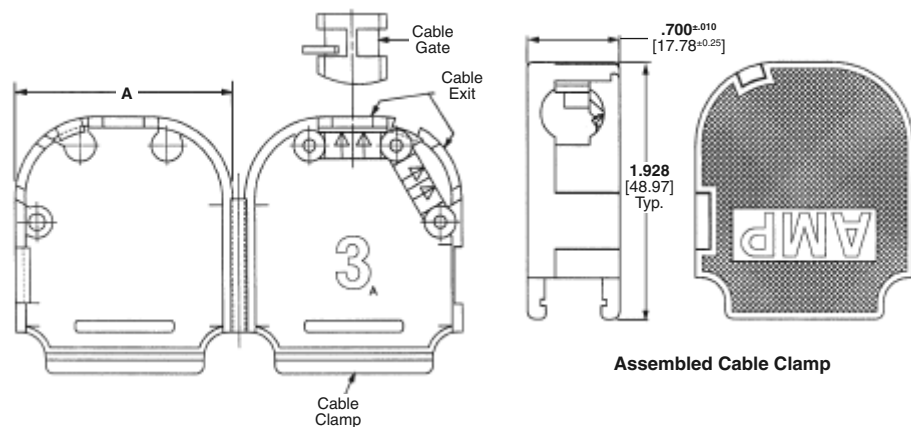

| Shell Size | Cable Dia. Range (Ref.) | Dimension A    | Kit Number* with Retainer Screws and Clips | Kit Number*** without Retainer Screws and Clips | Packaging |
|------------|-------------------------|----------------|--|---|-----------|
| 1          | .075-.250<br>1.91-6.35  | .785<br>19.94  | 5749914-1                                  | —   | Bulk Pkg. |
|            |                         |                | 5749914-2                                  | 5750100-1                                       | Unit Kit  |
|            |                         |                | 5749914-4**                                | —   | Unit Kit  |
| 3          | .180-.460<br>4.57-11.68 | 1.650<br>41.91 | 5749626-2                                  | 5750078-1                                       | Unit Kit  |
|            |                         |                | 5749916-2                                  | —   | Bulk Pkg. |
| 4          | .250-.550<br>6.35-13.97 | 2.285<br>58.04 | 5749916-2                                  | —   | Unit Kit  |

\*For metal-shell connectors only.  
 \*\*Type 2 Retainer Clip  
 \*\*\*For Metal-Shell or All-Plastic Connectors

**Note:** All part numbers are RoHS compliant.

## Unshielded Cable Connector and Clamp Kits

The AMPLIMITE Quik-Snap Backshell and Connector kit presents a complete package for your unshielded subminiature D connector needs. Kits are available for Shell Sizes 1, 2 and 3, and are packaged 25 and 100 kits per unit.

### One-Piece, All-Plastic Cable Clamp for Jacketed Cable, 180°/120° Exit and HDP-20 and HDE-20 Connector

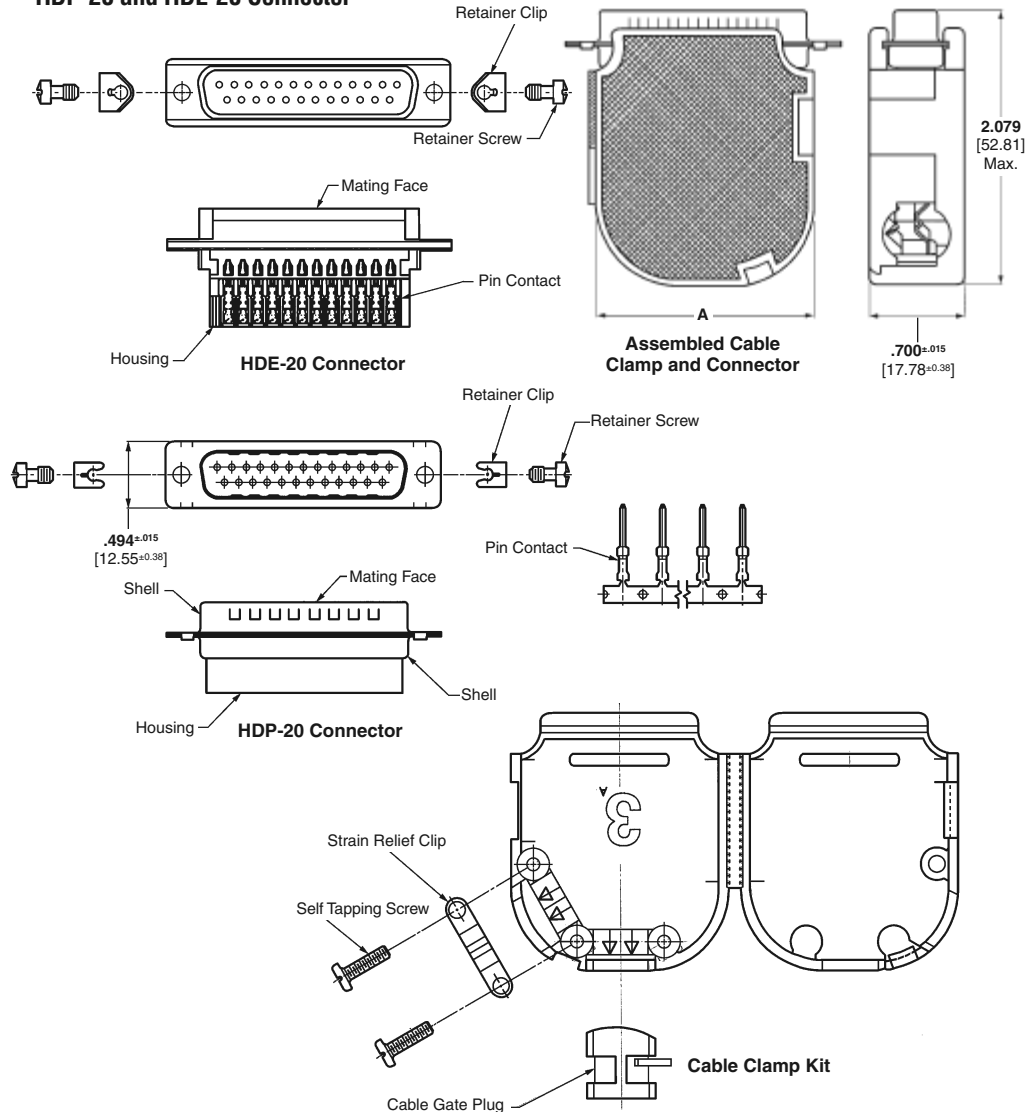

#### Each kit contains:

- 1-Hinged Plastic Clamp
- 2-Retention Screws
- 2-Retention Clips
- 1-Cable Gate Plug
- 1-Strain Relief Clip
- 2-Self Tapping Screws
- 1-Connector and Contacts

#### Material and Finish:

- Cover**—Polypropylene, black
- Retention Screws**—Steel, zinc plated
- Retention Clips**—Stainless steel
- Cable Gate Plug**—Polypropylene, Black
- Strain Relief Clip**—Stainless steel
- Self Tapping Screws**—Steel, zinc plated
- Contacts**—Brass (HDP Pins), Phosphor Bronze (All Others), plated gold flash on the mating end, .000100 [0.00254] min. tin or tin on the terminating end, all over .000030 [0.00076] min. nickel underplating
- Housing**—Polyester or nylon, glass-filled, UL rated 94V-0, black
- Shell**—Steel, plated .000200 [0.00508] min. tin over .000050 [0.00127] min. copper

#### Technical Documents:

**HDE Connectors:**  
**Instruction Sheets**—  
 408-6621

**Application Specifications**—  
 114-40002  
 114-40003

**HDP Connectors:**  
**Application Specifications**—  
 114-10000  
 114-40030

**Cable Clamps:**  
**Instruction Sheet**—408-9544

**Retention Clips:**  
**Instruction Sheet**—408-7837

#### Unshielded Cable Clamp Kits with HDP-20 Connectors

| Shell Size | Cable Dia. Range (Ref.) | Dimension A    | Plug Kit Part No. | Receptacle Kit Part No. | Packaging |
|------------|-------------------------|----------------|-------------------|-------------------------|-----------|
| 1          | .075-.250<br>1.91-6.35  | .785<br>19.94  | 749808-8          | 749812-7                | 100/pack  |
| 2          | .170-.380<br>4.32-9.65  | 1.110<br>28.19 | 749808-9          | —                       | 100/pack  |
| 3          | .180-.460<br>4.58-11.68 | 1.650<br>41.91 | 749808-7          | 1-749812-1              | 100/pack  |

#### Unshielded Cable Clamp Kits with HDE-20 All-Plastic Connectors

| Shell Size | Cable Dia. Range (Ref.) | Dimension A    | Plug Kit Part No. | Receptacle Kit Part No. | Packaging |
|------------|-------------------------|----------------|-------------------|-------------------------|-----------|
| 3          | .180-.460<br>4.58-11.68 | 1.650<br>41.91 | 749809-9          | 749813-8                | 100/pack  |

**Note:** All part numbers are RoHS compliant.

## Unshielded Cable Clamps

Low Profile Cable Clamps feature a two-piece construction which allows the two cover halves to be snapped together, no hardware is required for assembly. They can be used on plugs or receptacles and will not interfere with commonly used mating hardware. Sufficient Cable Support Gates (or a Cable Support Gate Latch) are supplied with each cable clamp kit to achieve adjustable clamping over a wide range of jacketed cable diameters.

### Material

Black thermoplastic

### Related Product Data:

#### Connectors used with:

**HDE All-Plastic**—pages 112 & 113

**HDE Metal-Shell**—pages 114 & 115

#### Other accessory capabilities:

**Male Screw Retainers**—

pages 146 & 147

**Female Screwlocks**—page 148

**Locking Posts and Slide Latches**—

pages 149-151

**Latching Blocks**—pages 153 & 154

### Straight Exit Low Profile for Jacketed Cable

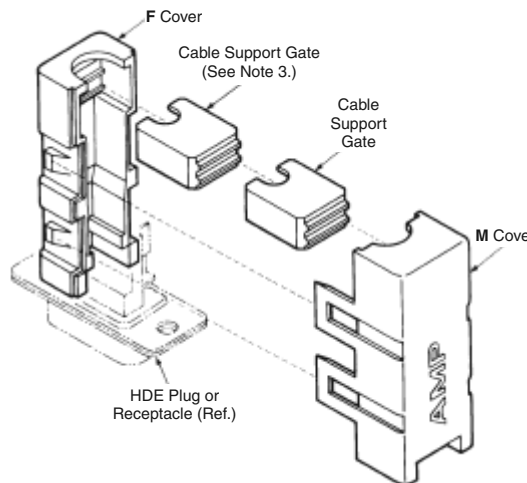
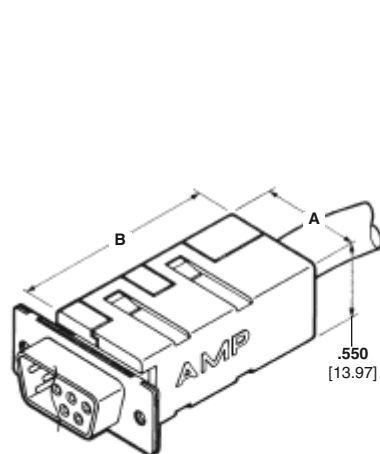

| Shell Size | Dimensions     |  | Cable Dia. (Max.) | Cable Clamp Kit No. |              |
|------------|----------------|--|-------------------|---------------------|--------------|
|            | A              | B  |                   | Individual          | Bulk Packed* |
| 1          | .732<br>18.59  | When used On Plug: 1.582<br>40.18<br>When used on Receptacle: 1.533<br>38.94 | .330<br>8.38      | 745547-1            | 745547-2     |
| 2          | 1.056<br>26.82 | When used On Plug: 1.582<br>40.18<br>When used on Receptacle: 1.533<br>38.94 | .425<br>10.80     | 745553-1            | 745553-2     |
| 3          | 1.604<br>40.74 | When used On Plug: 1.700<br>43.18<br>When used on Receptacle: 1.651<br>41.94 | .550<br>13.97     | 745560-1            | 745560-2     |

\*Each part is individually bulk packed for multiple kit orders.

- Notes:**
1. All parts are packaged unassembled.
  2. Each kit is comprised of two cover halves (F and M) and an assortment of cable support gates.
  3. Cable support gate must be used as shown for small diameter cable.

### 90° Exit Low Profile for Jacketed Cable

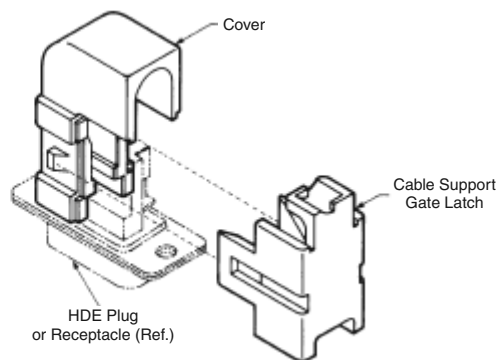
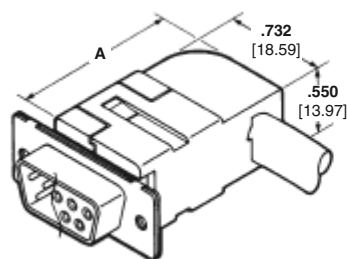

| Shell Size | Dimension A       |                         | Cable Dia. (Max.) | Cable Clamp Kit No. |
|------------|-------------------|-------------------------|-------------------|---------------------|
|            | When used on Plug | When used on Receptacle |                   | Individual          |
| 1          | 1.290<br>32.77    | 1.241<br>31.52          | .330<br>8.38      | 745550-1            |

- Notes:**
1. All parts are packaged unassembled.
  2. Each kit is comprised of a cover half and an assortment of cable support gate latches.

**Note:** All part numbers are RoHS compliant.



**Unshielded Cable Clamps** (Continued)

**Material**

Black thermoplastic

**Slide-On Back Covers**

**Related Product Data:**

**Connectors used with:**

**HDE All-Plastic**—pages 112 & 113

**HDE Metal-Shell**—pages 114 & 115

**Other accessory capabilities:**

**RFI/EMI Metal Shields**—pages 141 & 142

**Male Screw Retainers**—pages 146 & 147

**Locking Posts and Slide Latches**—pages 149-151

**Latching Blocks**—pages 153 & 154

**Technical Documents:**

**Instruction Sheet**—408-6658

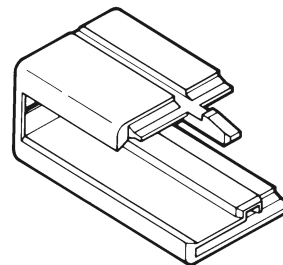
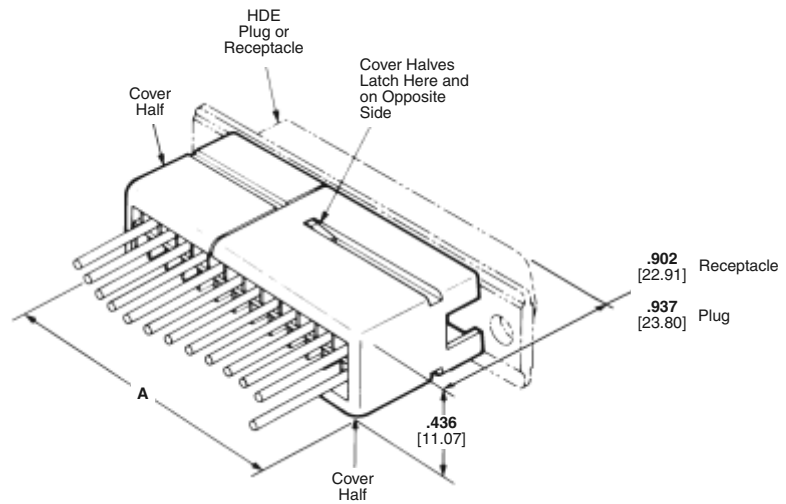

**Back Cover Half**  
(See Note 2.)

| Shell Size | Dim. A         | Back Cover Kit No. Individual |
|------------|----------------|-------------------------------|
| 1          | .610<br>15.49  | 745530-1                      |
| 2          | .934<br>23.72  | 745530-2                      |
| 3          | 1.482<br>37.64 | 745530-3                      |
| 4          | 2.134<br>54.20 | 745530-4                      |

- Notes:** 1. All parts are packaged unassembled.  
2. Each slide-on back cover kit includes two identical cover halves which snap together over the connector.

**Note:** All part numbers are RoHS compliant.



## Unshielded Cable Clamps (Continued)

Box and Lid Cable Clamps can be used on either plugs or receptacles and will not interfere with commonly used hardware. Their hinged construction allows easy assembly to a harness. A wide range of cable diameters are accommodated through the use of cable support gates, supplied with each cable clamp.

Cable clamps are available in kits with appropriate hardware for convenient plug/receptacle mating. See below for kits with Male Screw Retainers.

### Box and Lid Straight/90° Exit



Shell Size 1 & 2

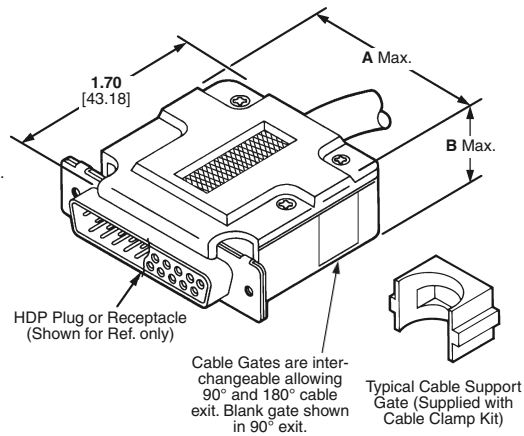

Shell Size 3 & 4 & 5

### Material and Finish:

- Cable Clamp Housing**—Thermoplastic, black with textured finish
- Gates**—Thermoplastic, black
- Flat Head Screws**—Steel, black, zinc plated

### Related Product Data:

- Connectors used with:**
- HDP Metal-Shell**—pages 90-102
- Other accessory capabilities:**
- Male Screw Retainers**—pages 146 & 147
- Female Screwlocks**—page 148
- Locking Posts and Slide Latches**—pages 149-151
- Spring Latches (Two Piece)**—page 152
- Latching Blocks**—pages 153 & 154

### Technical Documents:

- Instruction Sheet**—408-7555

### Material and Finish:

- Cable Clamp Housing**—Thermoplastic, black with textured finish
- Gates**—Thermoplastic, black
- Flat Head Screws**—Steel, black, zinc plated
- Male Screw**—Steel, zinc plated yellow chromate
- Retaining Clip**—Stainless steel

### Related Product Data:

- Connectors used with:**
- HDP Metal-Shell**—pages 90-102

### Technical Documents::

- Instruction Sheets**—408-7555, 408-7837

| Shell Size | Dimensions     |               | Cable Dia. Max. (Ref.) |                | Cable Clamp Kit No. |              |
|------------|----------------|---------------|------------------------|----------------|---------------------|--------------|
|            | A              | B             | Straight Cable Exit    | 90° Cable Exit | Individual          | Bulk Packed* |
| 1          | .755<br>19.18  | .630<br>16.00 | .160<br>4.06           | .160<br>4.06   | 207467-1            | 207467-2     |
| 2          | 1.078<br>27.38 | .630<br>16.00 | .320<br>8.13           | .320<br>8.13   | 207470-1            | —            |
| 3          | 1.620<br>41.15 | .770<br>19.56 | .390<br>9.91           | .390<br>9.91   | 207345-1            | 207345-2     |
| 4          | 2.268<br>57.61 | .770<br>19.56 | .640<br>16.26          | .405<br>10.29  | 207473-1            | 207473-2     |
| 5          | 2.178<br>55.32 | .880<br>22.35 | .490<br>12.45          | .490<br>12.45  | 207476-1            | —            |

\*Each part is individually bulk packed for multiple kit orders.

- Notes:**
1. All parts are packaged unassembled.
  2. Cable diameter is adjustable by changing cable support gates. Use the flat side of cable support gates for discrete wire, and the semicircle side for jacketed cable.
  3. Cable clamp assemblies are available in kits with male screw retainers, see below.

### Box and Lid Straight/90° Exit Cable Clamp Kits with Male Screw Retainers

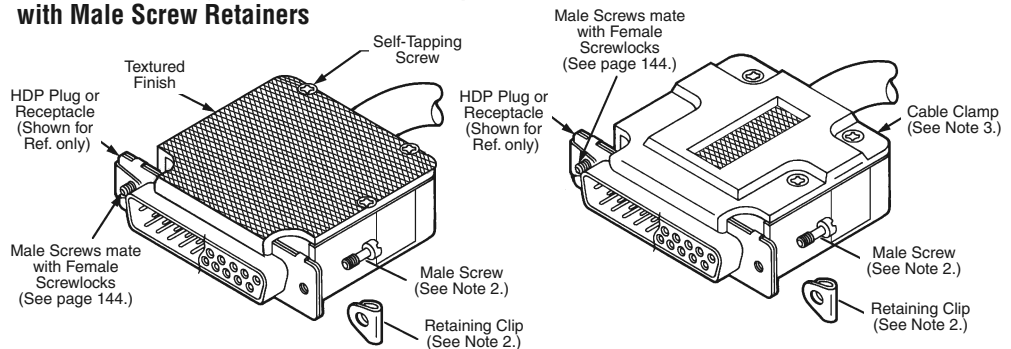

Shell Size 1 & 2

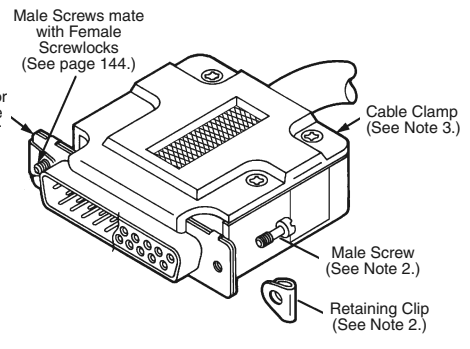

Shell Size 3 & 4 & 5

| Shell Size | Cable Clamp Kit No. |
|------------|---------------------|
| 1          | 5207908-1           |
| 2          | 5207908-4           |
| 3          | 5207908-7           |
| 4          | 1-5207908-0         |
| 5          | 1-5207908-3         |

- Notes:**
1. All parts are packaged unassembled.
  2. Each kit is comprised of a cable clamp and male screw retainer hardware (2 each). Male screw retainers are also available in kit form, see page 146.
  3. For ordering cable clamps separately, see above.

**Note:** All part numbers are RoHS compliant.

## Unshielded Cable Clamps (Continued)

Straight/45° Exit Cable Clamps can be used on either a plug or receptacle and will not interfere with commonly used hardware, such as Male Screw Retainers, Female Screw-locks or Spring Latches and Latching Blocks. Their hinged construction allows easy assembly to a harness. Also, the straight or 45° angle of the cable exit is achieved by merely positioning the Cable Support Gate for the desired angle prior to installing the assembly onto the plug or receptacle. Adjustable screws are used to tighten cable strain reliefs.

Cable Clamp assemblies are available in kits with appropriate hardware for convenient plug/receptacle mating.

### Material and Finish:

- Cable Clamp Housing**—Thermoplastic, black with textured finish
- Gates**—Thermoplastic, black
- Pan Head Screws, 6-32 Set Screw and 6-32 Square Nut**—Steel, zinc plated (sizes 1 and 2 include self-tapping screws only)

### Related Product Data:

- Connectors used with:**
- HDP Metal-Shell**—pages 90-102
- Other accessory capabilities:**
- Male Screw Retainers**—pages 146 & 147
- Female Screwlocks**—page 148
- Locking Posts and Slide Latches**—pages 149-151
- Spring Latches (Two Piece)**—page 152
- Latching Blocks**—pages 153 & 154

### Technical Documents:

**Instruction Sheet**—408-7555

### Material and Finish:

- Cable Clamp Housing**—Thermoplastic, black with textured finish
- Gates**—Thermoplastic, black
- Pan Head Screws, 6-32 Set Screw and 6-32 Square Nut**—Steel, zinc plated (sizes 1 and 2 include self-tapping screws only)
- Male Screw**—Steel, zinc plated yellow chromate
- Retaining Clip**—Stainless steel

### Related Product Data:

**Connectors used with:**  
**HDP Metal-Shell**—pages 90-102

### Technical Documents:

**Instruction Sheets**—  
408-7555  
408-7837

**Note:** All part numbers are RoHS compliant.

### Clam Shell Straight/45° Exit

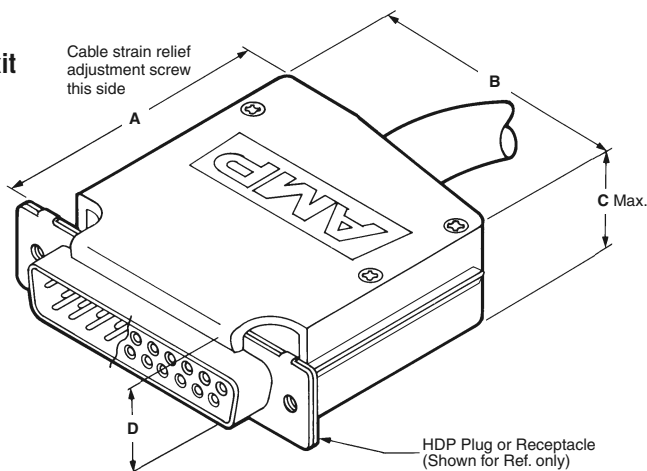

| Shell Size | Dimensions |       |       |       | Cable Dia. (Max.) | Short Cable Clamp Part No. |              | Standard Cable Clamp Part No. |              |
|------------|------------|-------|-------|-------|-------------------|----------------------------|--------------|-------------------------------|--------------|
|            | A          | B     | C     | D     |                   | Individual                 | Bulk Packed* | Individual                    | Bulk Packed* |
| 1          | 1.625      | .750  | .640  | .640  | .256              | —                          | —            | 5205729-1                     | 5205729-3    |
|            | 41.28      | 19.05 | 16.26 | 16.26 | 6.30              | —                          | —            | —                             | —            |
| 2          | 1.250      | 1.073 | .600  | .640  | .320              | 5206393-1                  | —            | —                             | —            |
|            | 31.75      | 27.25 | 15.24 | 16.26 | 8.13              | —                          | —            | 5205730-1                     | 5205730-3    |
| 3          | 1.625      | 1.073 | .640  | .640  | .320              | —                          | —            | 5205730-1                     | 5205730-3    |
|            | 41.28      | 27.25 | 16.26 | 16.26 | 8.13              | —                          | —            | —                             | —            |
| 3          | 1.250      | 1.615 | .600  | .640  | .420              | 5206390-1                  | 5206390-3    | —                             | —            |
|            | 31.75      | 41.02 | 15.24 | 16.26 | 10.67             | —                          | —            | 5205718-1                     | 5205718-4    |
| 4          | 1.625      | 1.615 | .640  | .640  | .420              | —                          | —            | 5205718-1                     | 5205718-4    |
|            | 41.28      | 41.02 | 16.26 | 16.26 | 10.67             | —                          | —            | —                             | —            |
| 4          | 1.625      | 2.263 | .640  | .640  | .490              | —                          | —            | 5205731-1                     | —            |
|            | 41.28      | 57.48 | 16.26 | 16.26 | 12.45             | —                          | —            | —                             | —            |

\*Each part is individually bulk packed for multiple assembly orders.

- Notes:**
1. All parts are packed unassembled.
  2. Quantity of pan head screws supplied with cable clamp assembly varies with shell size.
  3. Cable clamps are available in kits with male screw retainers, see below.
  4. All pan head screws have combination cross-recessed and slotted heads.

### Clam Shell Straight/45° Exit Cable Clamp Kits with Male Screw Retainers

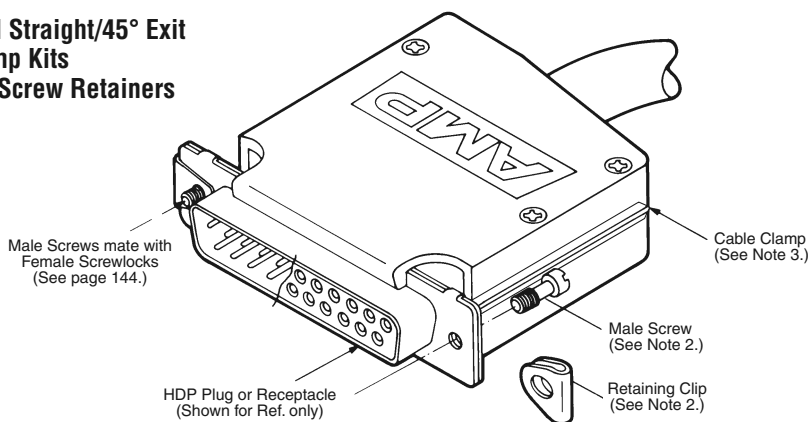

| Shell Size | Short Cable Clamp Kit No. |              | Standard Cable Clamp Kit No. |              |
|------------|---------------------------|--------------|------------------------------|--------------|
|            | Individual                | Bulk Packed* | Individual                   | Bulk Packed* |
| 1          | —                         | —            | 5206478-1                    | —            |
| 2          | —                         | —            | 5206478-2                    | —            |
| 3          | 1-5206478-2               | 2-5206478-6  | 5206478-3                    | 2-5206478-2  |
| 4          | —                         | —            | 5206478-4                    | —            |
| 5          | —                         | —            | 5206478-5                    | —            |

\*Each part is individually bulk packed for multiple assembly orders.

- Notes:**
1. All parts are packaged unassembled.
  2. Each kit is comprised of a cable clamp and male screw retainer hardware (2 each). Male screw retainers are also available in kit form, see page 146.
  3. For ordering cable clamps separately, see above.

## Unshielded Cable Clamps (Continued)

**Material and Finish:**

- Cable Clamp Housing**—Nylon, black
- 4-40 Fillister Head Screws & Hex Nuts**—Steel, clear zinc plated
- Jackscrews**—Steel, black zinc plated

**Related Product Data:**  
**Connectors used with:**  
**HDP Metal-Shell**—pages 90-102

### Straight Exit Dataphone

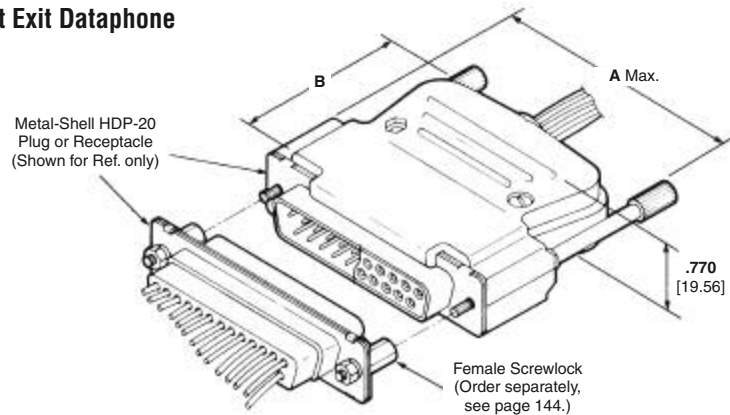

| Shell Size | Dimensions     |                | Max. Cable Dia. (without Gate) | Max. Cable Dia. (with Gate) | Cable Gate Identification* | Thread Size | Cable Clamp Kit No. |
|------------|----------------|----------------|--------------------------------|-----------------------------|----------------------------|-------------|---------------------|
|            | A              | B              |                                |                             |                            |             |                     |
| 2          | 1.575<br>40.01 | 1.312<br>33.32 | .400<br>10.16                  | .200<br>5.08                | 2A                         | 4-40        | 5745122-2           |
|            |                |                |                                | .260<br>6.60                | 2B                         |             |                     |
|            |                |                |                                | .320<br>8.13                | 2C                         |             |                     |
| 3          | 2.115<br>53.72 | 1.421<br>36.09 | .500<br>12.70                  | .250<br>6.35                | 3A                         | 4-40        | 5745121-2           |
|            |                |                |                                | .340<br>8.64                | 3B                         |             |                     |
|            |                |                |                                | .420<br>10.67               | 3C                         |             |                     |

\*Molded-in identification (as shown in chart above) is provided on cable support gates to facilitate proper selection with regard to shell size and maximum acceptable cable diameter.

- Notes:** 1. All parts are packaged unassembled.  
 2. Cable diameter is adjustable by changing cable support gates.

### Straight Exit for Jacketed Cable (Two-Piece)

This cable clamp allows cable to be fully prepared and terminated before the clamp is installed.

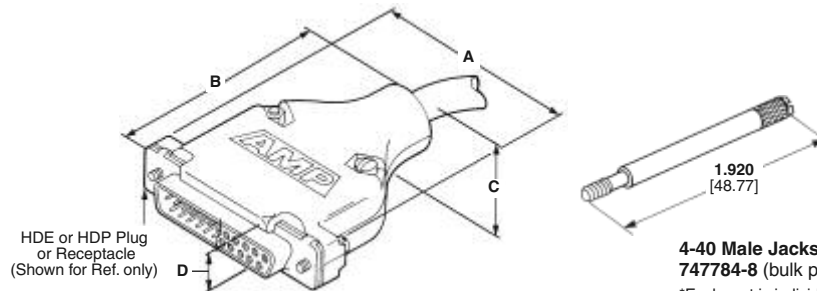

- Material and Finish:**
- Cable Clamps**—ABS black
  - 4-40 Fillister Head Screws and Hex Nuts**—Steel, zinc plated
  - 4-40 Mounting Screws**—Steel, zinc plated
  - Jackscrews**—Stainless steel, passivated

**4-40 Male Jackscrew Kit Nos.:**  
**747784-8** (bulk packed)\*†

\*Each part is individually bulk packed for multiple kit orders.  
 †Slotted for screwdriver use.

### Cable Clamp Kits with Grommets

| Shell Size | Dimensions     |                |               |               | Cable O.D. Range        | No. of Grommets Per Set | Kit Numbers |
|------------|----------------|----------------|---------------|---------------|-------------------------|-------------------------|-------------|
|            | A              | B              | C             | D             |                         |                         |             |
| 1          | 1.215<br>30.86 | 1.910<br>48.51 | .570<br>14.48 | .630<br>16.00 | .185-.320<br>4.70-8.13  | 4                       | 5748678-1   |
| 2          | 1.545<br>39.24 | 1.910<br>48.51 | .620<br>15.75 | .620<br>15.75 | .185-.320<br>4.70-8.13  | 4                       | 5748678-2   |
| 3          | 2.090<br>53.09 | 1.920<br>48.77 | .680<br>17.27 | .640<br>16.26 | .255-.470<br>6.48-11.94 | 6                       | 5748678-3   |
| 4          | 2.738<br>69.55 | 1.920<br>48.77 | .800<br>20.32 | .620<br>15.75 | .255-.470<br>6.48-11.94 | 6                       | 5748678-4   |
| 5          | 2.644<br>67.16 | 1.920<br>48.77 | .900<br>22.86 | .730<br>18.54 | .255-.470<br>6.48-11.94 | 6                       | 5748678-5   |

- Notes:** 1. All parts are packaged unassembled.  
 2. Jackscrews must be purchased separately.  
 3. Split-ring and crimp ferrules are shown on pages 143-145.  
 4. Shielded cable clamps will not accept connector housings with clinch nuts.

**Note:** All part numbers are RoHS compliant.

**Related Product Data:**  
**Ferrules**—pages 143-145  
**Connectors used with:**  
**HDE Metal-Shell**—pages 114 & 115  
**HDP Metal-Shell**—pages 90-102  
**Other accessory capabilities:**  
**Spring Latch (Two-Piece)**—page 152

**Technical Documents:**  
**Instruction Sheet**—408-6609

**Unshielded Cable Clamps** (Continued)

Cable Connectors

Straight/90° Exit Cable Clamps can be used on a plug or receptacle and will not interfere with commonly used mating hardware. Their three-piece construction allows easy assembly to a cable harness. Also, the same cable clamp components are used for both straight and 90° cable exit applications. This is accomplished by simply positioning the Male and Female Panels on the Yoke for the desired angle.

**Material**

Black thermoplastic

**Related Product Data:**

**Connectors used with:**

**HDE All-Plastic**—pages 112 & 113

**HDE Metal-Shell**—pages 114 & 115

**HDP Metal-Shell**—pages 90-102

**Other accessory capabilities:**

**Female Screwlocks**—page 148

**Locking Posts and Slide Latches**—pages 149-151

**Latching Blocks**—pages 153 & 154

**Straight/90° Exit**

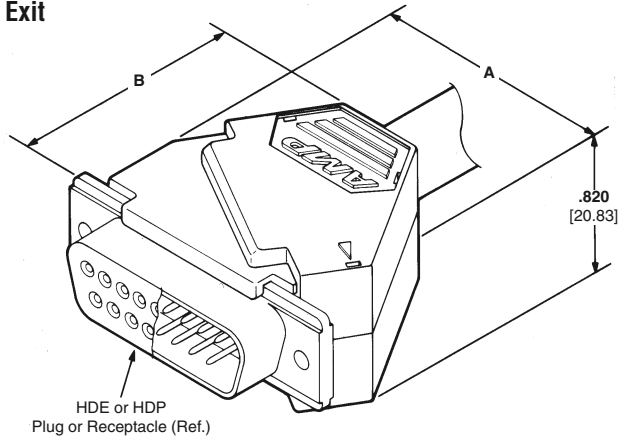

**Straight Cable Exit Application**

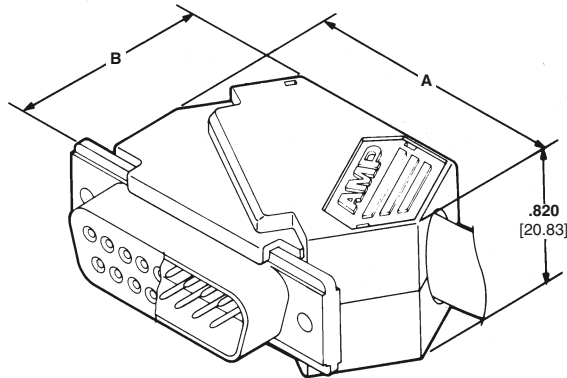

**90° Cable Exit Application**

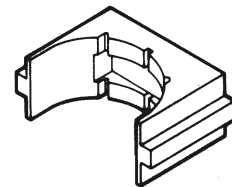

**Typical Cable Support Gate**  
(Supplied with Cable Clamp Kit)

| Shell Size | Cable Clamp Configuration | Dimensions |       | Cable Dia. | Cable Clamp Kit No. Individual |
|------------|---------------------------|------------|-------|------------|--------------------------------|
|            |                           | A          | B     |            |                                |
| 3          | Straight Exit             | 1.906      | 1.672 | .550       | 745306-1                       |
|            | 90° Exit                  | 2.066      | 1.396 |            |                                |
| 4          | Straight Exit             | 2.424      | 1.820 | .750       | 745311-1                       |
|            | 90° Exit                  | 2.638      | 1.596 |            |                                |

- Notes:** 1. All parts are packaged unassembled.  
2. Each cable clamp assembly includes a yoke, male panel, female panel and four cable support gates. The cable diameter is adjustable by changing the cable support gates.

**Note:** All part numbers are RoHS compliant.

## Shielded Cable Clamps

### Straight Exit RFI/EMI Shields for Jacketed Cable (Two-Piece)

This RFI/EMI shield allows cable to be fully prepared and terminated to the connector before the shield is installed. During installation, the shield of the jacketed cable is folded back and compressed into the cable opening of the RFI/EMI shield. For greater cable support and/or shielding effectiveness, split-ring and crimp ferrules are available (pages 143-145).

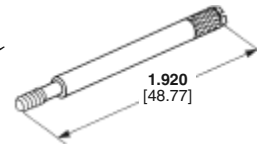
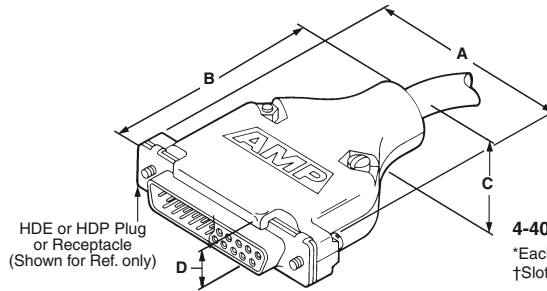

**4-40 Male Jackscrew Kit Nos.: 747784-8 (bulk packed)\*†**  
 \*Each part is individually bulk packed for multiple kit orders.  
 †Slotted for screwdriver use.

### Material and Finish:

- Die Cast Shield**—Zinc alloy, plated bright nickel over bright copper
- Metal-Plated Plastic Shield**—Thermoplastic, plated nickel over copper
- 4-40 Fillister Head Screws and Hex Nuts**—Steel, zinc plated
- 4-40 Mounting Screws**—Steel, zinc plated
- Jackscrews**—Stainless steel, passivated

### Related Product Data:

- Ferrules**—pages 143-145
- Connectors used with:**
- HDE Metal-Shell**—pages 114 & 115
- HDP Metal-Shell (Tin plated only)**—pages 90-102
- Other accessory capabilities:**
- Spring Latch (Two-Piece)**—page 152

### Technical Documents:

- Product Specification**—108-40032
- Instruction Sheet**—408-6609

| Shell Size | Dimensions     |                |                 |                 | Cable O.D. (Max.) | Die Cast Shield Kit Numbers | Metal-Plated Plastic Shield Kit Numbers | Grommet Sets            |                         | Part Number |
|------------|----------------|----------------|-----------------|-----------------|-------------------|-----------------------------|---|-------------------------|-------------------------|-------------|
|            | A              | B              | C               | D               |                   |                             |   | Cable O.D. Range        | No. of Grommets Per Set |             |
| 1          | 1.215<br>30.86 | 1.910<br>48.51 | .550**<br>13.97 | .620**<br>15.75 | .200<br>5.08      | 5745171-2                   | 5745854-5                               | —                       | —                       | —           |
|            |                |                |                 |                 | .250<br>6.35      | 5745171-1                   | 5745854-3                               | —                       | —                       | —           |
|            |                |                |                 |                 | .370<br>9.40      | 5745171-5                   | 5745854-1                               | .185-.320<br>4.70-8.13  | 4                       | 747746-1    |
|            |                |                |                 |                 | .225<br>5.72      | 5745172-3                   | 5747099-7                               | —                       | —                       | —           |
| 2          | 1.545<br>39.24 | 1.910<br>48.51 | .620<br>15.75   | .620<br>15.75   | .300<br>7.62      | 5745172-2                   | 5747099-5                               | —                       | —                       | —           |
|            |                |                |                 |                 | .375<br>9.53      | 5745172-1                   | 5747099-3                               | .185-.320<br>4.70-8.13  | 4                       | 747746-1    |
|            |                |                |                 |                 | .430<br>10.92     | 1-5745172-3                 | 5747099-1                               | —                       | —                       | —           |
|            |                |                |                 |                 | .280<br>7.11      | 5745173-5                   | 5745833-9                               | —                       | —                       | —           |
| 3          | 2.090<br>53.09 | 1.920<br>48.77 | .680<br>17.27   | .620**<br>15.75 | .350<br>8.89      | 5745173-4                   | 5745833-7                               | —                       | —                       | —           |
|            |                |                |                 |                 | .430<br>10.92     | 5745173-3                   | 5745833-5                               | —                       | —                       | —           |
|            |                |                |                 |                 | .480<br>12.19     | 5745173-2                   | 5745833-4                               | —                       | —                       | —           |
|            |                |                |                 |                 | .530<br>13.46     | 5745173-1                   | 5745833-1                               | .255-.470<br>6.48-11.94 | 6                       | 747973-1    |
| 4          | 2.738<br>69.55 | 1.920<br>48.77 | .800<br>20.32   | .620<br>15.75   | .350<br>8.89      | 5745174-5                   | 5747100-9                               | —                       | —                       | —           |
|            |                |                |                 |                 | .425<br>10.80     | 5745174-4                   | 5747100-7                               | —                       | —                       | —           |
|            |                |                |                 |                 | .500<br>12.70     | 5745174-3                   | —                                       | —                       | —                       | —           |
|            |                |                |                 |                 | .530<br>13.46     | 2-5745174-7                 | —                                       | .255-.470<br>6.48-11.94 | 6                       | 747973-1    |
| 5          | 2.644<br>67.16 | 1.920<br>48.77 | .900<br>22.86   | .730<br>18.55   | .575<br>14.61     | 5745174-2                   | 5747100-3                               | —                       | —                       | —           |
|            |                |                |                 |                 | .650<br>16.51     | 5745174-1                   | 5747100-1                               | —                       | —                       | —           |
|            |                |                |                 |                 | .375<br>9.53      | 5745175-6                   | —                                       | —                       | —                       | —           |
|            |                |                |                 |                 | .450<br>11.43     | 5745175-5                   | —                                       | —                       | —                       | —           |
| 5          | 2.644<br>67.16 | 1.920<br>48.77 | .900<br>22.86   | .730<br>18.55   | .525<br>13.34     | 5745175-4                   | —                                       | .255-.470<br>6.48-11.94 | 6                       | 747973-1    |
|            |                |                |                 |                 | .600<br>15.24     | 5745175-3                   | —                                       | —                       | —                       | —           |
|            |                |                |                 |                 | .675<br>17.15     | 5745175-2                   | —                                       | —                       | —                       | —           |
|            |                |                |                 |                 | .750<br>19.05     | 5745175-1                   | 5747098-1                               | —                       | —                       | —           |

### Cable Clamp Kits with Grommets

| Shell Size | Dimensions     |                |                 |                 | Cable O.D. Range        | No. of Grommets Per Set | Kit Numbers                   |   |
|------------|----------------|----------------|-----------------|-----------------|-------------------------|-------------------------|-------------------------------|---|
|            | A              | B              | C               | D               |                         |                         | Die Cast Shield With Grommets | Metal-Plated Plastic Shield With Grommets |
| 1          | 1.215<br>30.86 | 1.910<br>48.51 | .550**<br>13.97 | .620**<br>15.75 | .185-.320<br>4.70-8.13  | 4                       | 5748676-1                     | 5748677-1                                 |
| 2          | 1.545<br>39.24 | 1.910<br>48.51 | .620<br>15.75   | .620<br>15.75   | .185-.320<br>4.70-8.13  | 4                       | 5748676-2                     | 5748677-2                                 |
| 3          | 2.090<br>53.09 | 1.920<br>48.77 | .680<br>17.27   | .620**<br>15.75 | .255-.470<br>6.48-11.94 | 6                       | 5748676-3                     | 5748677-3                                 |
| 4          | 2.738<br>69.55 | 1.920<br>48.77 | .800<br>20.32   | .620<br>15.75   | .255-.470<br>6.48-11.94 | 6                       | 5748676-4                     | 5748677-4                                 |
| 5          | 2.644<br>67.16 | 1.920<br>48.77 | .900<br>22.86   | .730<br>18.54   | .255-.470<br>6.48-11.94 | 6                       | 5748676-5                     | 5748677-5                                 |

- Notes:**
- All parts are packaged unassembled.
  - Jackscrews must be purchased separately.
  - Split-ring and crimp ferrules are shown on pages 143-145.
  - Shielded cable clamps will not accept connector housings with clinch nuts.

\*\* The following dimensions apply to metal-plated plastic cable clamps: Size 1: C = .570 [14.48], D = .630 [16.0] Size 3: D = .640 [16.26]

**Note:** All part numbers are RoHS compliant.



**Shielded Cable Clamps** (Continued)

Both the straight exit and the 90° exit die cast RFI/EMI shield allows cable to be fully prepared and terminated to the connector before the shield is installed. During installation, the shield of the jacketed cable is folded back and compressed into the cable opening of the RFI/EMI shield. For greater cable support and/or shielding effectiveness, splitting and crimp ferrules are available (pages 143-145).

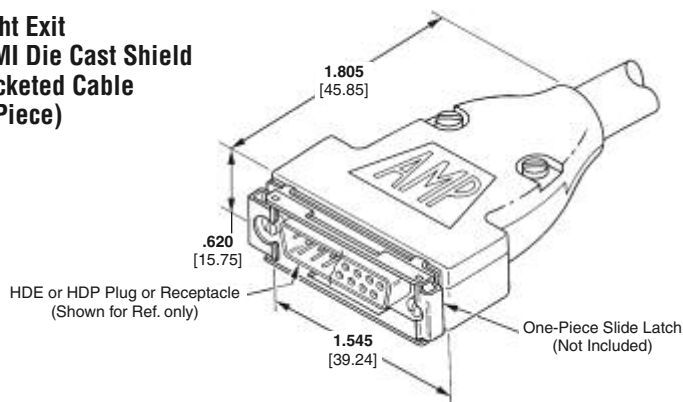
**Straight Exit RFI/EMI Die Cast Shield for Jacketed Cable (Two-Piece)**

**Material and Finish:**

**Shield**—Zinc alloy, plated nickel over copper

**4-40 Pan Head Screws & Latch Screws (90° Exit Only)**—Steel, zinc plated

**One-Piece Slide Latch (90° Exit Only)**—Stainless steel

**Related Product Data:**

**Ferrules**—pages 143-145

**Connectors used with:**  
**HDE Metal-Shell**—pages 114 & 115  
**HDP Metal-Shell (Tin plated only)**—pages 90-102

**Technical Documents:**

**Product Specification**—108-40032

**Instruction Sheet**—408-6769

| Shell Size | No. of Positions | ID Letter | Cable Dia. w/Ferrules   | Part Number | Grommet Kit |
|------------|------------------|-----------|-------------------------|-------------|-------------|
| 2          | 15               | E         | .260-.300<br>6.60-7.72  | 5745919-3   | —           |
|            |                  | H         | .190-.375<br>4.83-9.53  | 5745919-2   | 747746-1*   |
|            |                  | K         | .190-.430<br>4.83-10.92 | 5745919-1   | —           |

\*Cable Dia. Range using Grommet is .185-.320 [4.70-8.13].

- Notes:**
1. All parts packaged unassembled.
  2. Each kit comprised of a two-piece shield with 2 pan head screws.
  3. Split-ring and crimp ferrules are shown on pages 143-145.

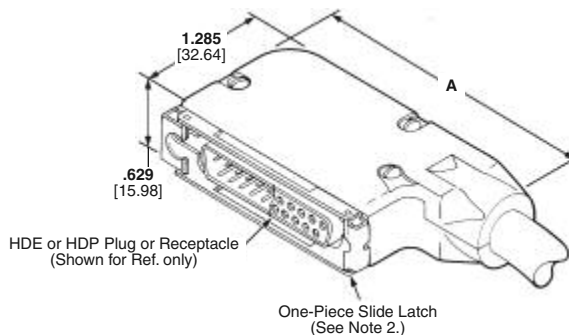
**90° Exit RFI/EMI Die Cast Shields for Jacketed Cable (Two-Piece)**

| Shell Size | Dimension A    | Cable Dia. w/Ferrules    | Shield with Slide Latch Kit Numbers (See Note 2) | Shield without Slide Latch Kit Numbers (See Note 3) | Grommet Kit |
|------------|----------------|--------------------------|--|---|-------------|
| 2          | 2.310<br>58.67 | .185-.225<br>4.70-6.48   | 5745652-4  | —   | —           |
|            |                | .260-.300<br>6.60-7.62   | 5745652-3  | —   | —           |
|            |                | .190-.375<br>4.83-9.53   | 5745652-2*                                       | —   | 747746-1    |
|            |                | .190-.430<br>4.83-10.92  | 5745652-1  | —   | —           |
|            |                | .240-.280<br>6.10-7.11   | 5745653-5  | —   | —           |
|            |                | .315-.355<br>8.00-9.02   | 5745653-4  | —   | —           |
| 3          | 2.850<br>72.39 | .190-.430<br>4.83-10.92  | 5745653-3  | 5747194-3   | —           |
|            |                | .440-.480<br>11.18-12.19 | 5745653-2  | —   | —           |
|            |                | .380-.530<br>9.65-13.46  | 5745653-1*                                       | —   | 747973-1    |

\* Cable Dia. with Grommet Kit: Size 2 = .185-.320 [4.70-8.13]; Size 3 = .255-.470 [6.48-11.94].

- Notes:**
1. All parts are packaged unassembled.
  2. Each kit is comprised of a two-piece shield with three pan head screws and a slide latch with two 4-40 slide latch screws.
  3. Each kit is comprised of a two-piece shield with three pan head screws.
  4. Split-ring and crimp ferrules are shown on pages 143-145.

**Note:** All part numbers are RoHS compliant.



**Shielded Cable Clamps** (Continued)

**Material and Finish:**

**Outer Ferrule**—Copper, plated .000100 [0.00254] min. tin  
**Inner Ferrule**—.023 [0.58] thick brass, plated .000050 [0.00127] tin over copper

**Related Product Data:**

**Shields used with:**  
**Straight Exit**—pages 141 & 142  
**90° Exit**—page 142

**Technical Documents:**

**Product Specification**—108-40032  
**Instruction Sheets**—408-9315 Hand Tool  
 408-9318 Die Sets

**Crimp Ferrules for Braided Cable Shield**  
 (See pages 144 & 145 for Inner and Outer Ferrule Part Numbers.)

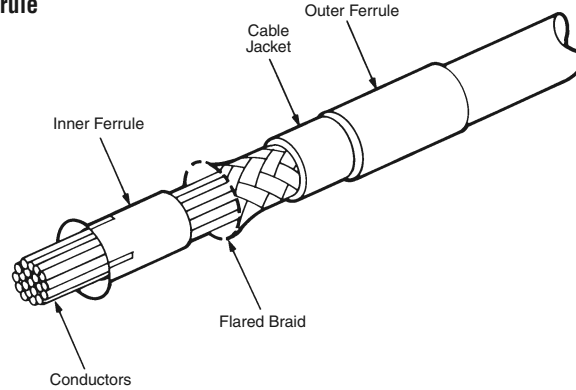

**Application Tooling**

**Note:** Crimp ferrules are for use with braided shields only. Crimp ferrules require application tooling with die sets for attachment to cable.



**Pneumatic Bench Tool No. 312522-2**  
 (Requires Die Set Holder No. 58449-1.)



**AMP Hand Tool No. 543344-1**  
 (See pages 144 & 145 for Hand Tool Die Set Numbers)

**Split-Ring Ferrules for Foil or Braided Cable Shield**  
 (See pages 144 & 145 for Split-Ring Ferrule Part Numbers.)

**Material:**

Aluminum

**Related Product Data:**

**Shields used with:**  
**Straight Exit**—pages 141 & 142  
**90° Exit**—page 142

**Technical Document**

**Product Specification**—108-40032



**Note:** Split-ring ferrules cannot be used with outer and inner ferrules. Split-ring ferrules are suitable for both foil and braided shields. The ferrules do not require tooling for assembly.

**Note:** All part numbers are RoHS compliant.

**Shielded Cable Clamps** (Continued)

**Crimp and Split-Ring Ferrules**

Cable Connectors

| Shell Size    | Cable Dia. (Max.) | When using these Shield Kits |                      |                                  |                     | Use these Ferrules      |                                     |            |                                |                    |
|---------------|-------------------|------------------------------|----------------------|----------------------------------|---------------------|-------------------------|-------------------------------------|------------|--------------------------------|--------------------|
|               |                   | Straight Exit Shield Kit No. |                      | 90° Exit Die Cast Shield Kit No. |                     | Split-Ring* Ferrule No. | Crimp Ferrule No. and Tooling No.** |            |                                |                    |
|               |                   | Die Cast                     | Metal-Plated Plastic | With Slide Latch                 | Without Slide Latch |                         | Inner                               | Outer      | Die Set For Hand Tool 543344-1 | Applicator Die Set |
| 1             | .200<br>5.08      | 5745171-2                    | 5745854-5            | —                                | —                   | 745508-2                | —                                   | —          | —                              | —                  |
|               | .240<br>6.10      | 5745171-5                    | 5745854-1            | —                                | —                   | —                       | 7-745129-8                          | 3-745130-8 | 543013-2                       | 813809-1           |
|               | .250<br>6.35      | 5745171-1                    | 5745854-3            | —                                | —                   | 745508-3                | —                                   | —          | —                              | —                  |
|               | .280<br>7.11      | 5745171-5                    | 5745854-1            | —                                | —                   | —                       | 7-745129-9                          | 4-745130-5 | 1-543013-7                     | 813809-7           |
|               | .370<br>9.40      | 5745171-5                    | 5745854-1            | —                                | —                   | 745508-6                | 6-745129-9                          | 4-745130-0 | 543013-6                       | 813809-5           |
|               | .225<br>5.72      | 5745172-3                    | 5747099-7            | 5745652-4                        | —                   | 745508-3                | —                                   | —          | —                              | —                  |
| 2             | .240<br>6.10      | 5745172-1                    | 5747099-3            | 5745652-2                        | —                   | —                       | 7-745129-8                          | 3-745130-8 | 543013-2                       | 813809-1           |
|               | .240<br>6.10      | 1-5745172-3<br>5745919-1     | 5747099-1            | 5745652-1                        | —                   | —                       | 7-745129-3                          | 3-745130-8 | 543013-3                       | 813809-1           |
|               | .280<br>7.11      | 1-5745172-3<br>5745919-1     | 5747099-1            | 5745652-1                        | —                   | —                       | 7-745129-8                          | 4-745130-5 | 1-543013-6                     | 813809-7           |
|               | .300<br>7.62      | 5745172-2<br>5745919-3       | 5747099-5            | 5745652-3                        | —                   | 745508-4                | —                                   | —          | —                              | —                  |
|               | .350<br>8.90      | 1-5745172-3<br>5745919-1     | 5747099-1            | 5745652-1                        | —                   | —                       | 7-745129-2                          | 3-745130-9 | 543013-4                       | 813809-2           |
|               | .365<br>9.27      | 5745172-1                    | 5747099-3            | 5745652-2                        | —                   | —                       | 6-745129-9                          | 4-745130-0 | 543013-6                       | 813809-5           |
| 3             | .375<br>9.53      | 5745172-1<br>5745919-2       | 5747099-3            | 5745652-2                        | —                   | 745508-6                | —                                   | —          | —                              | —                  |
|               | .430<br>10.92     | 1-5745172-3<br>5745919-1     | 5747099-1            | 5745652-1                        | —                   | 745508-1                | 7-745129-1                          | 4-745130-1 | 543013-7                       | 813809-3           |
|               | .240<br>6.10      | 5745173-3                    | 5745833-5            | 5745653-3                        | 5747194-3           | —                       | 7-745129-3                          | 3-745130-8 | 543013-3                       | 813809-1           |
|               | .280<br>7.11      | 5745173-5                    | 5745833-9            | 5745653-5                        | —                   | 745508-4                | —                                   | —          | —                              | —                  |
|               | .280<br>7.11      | 5745173-3                    | 5745833-5            | 5745653-3                        | 5747194-3           | —                       | 7-745129-8                          | 4-745130-5 | 1-543013-6                     | 813809-7           |
|               | .350<br>8.90      | 5745173-4                    | 5745833-7            | 5745653-4                        | —                   | 745508-5                | —                                   | —          | —                              | —                  |
| 3             | .350<br>8.90      | 5745173-3                    | 5745833-5            | 5745653-3                        | 5747194-3           | —                       | 7-745129-2                          | 3-745130-9 | 543013-4                       | 813809-2           |
|               | .430<br>10.92     | 5745173-3                    | 5745833-5            | 5745653-3                        | 5747194-3           | 745508-1                | 7-745129-1                          | 4-745130-1 | 543013-7                       | 813809-3           |
|               | .430<br>10.92     | 5745173-1                    | 5745833-1            | 5745653-1                        | —                   | —                       | 7-745129-5                          | 4-745130-1 | 543013-8                       | 813809-3           |
|               | .480<br>12.19     | 5745173-2                    | —                    | 5745653-2                        | —                   | 745508-8                | —                                   | —          | —                              | —                  |
| .530<br>13.46 | 5745173-1         | 5745833-1                    | 5745653-1            | —                                | 745508-9            | 7-745129-4              | 4-745130-2                          | 1-543013-0 | 813809-4                       |                    |

\*For split-ring ferrules, Min. O.D. is .040 [1.02] smaller than Max. O.D.

\*\*For inner and outer ferrules, Min. O.D. is .050 [1.27] smaller than Max. O.D. At the Max. cable O.D. the Min. insulation thickness is .060 [1.52].

Continued on Page 145

**Note:** All part numbers are RoHS compliant.

**Shielded Cable Clamps** (Continued)

**Crimp and Split-Ring Ferrules** (Continued)

| Shell Size    | Cable Dia. (Max.) | When using these Shield Kits |                      |                                  |                     | Use these Ferrules      |                                     |            |                               |                    |
|---------------|-------------------|------------------------------|----------------------|----------------------------------|---------------------|-------------------------|-------------------------------------|------------|-------------------------------|--------------------|
|               |                   | Straight Exit Shield Kit No. |                      | 90° Exit Die Cast Shield Kit No. |                     | Split-Ring* Ferrule No. | Crimp Ferrule No. and Tooling No.** |            |                               |                    |
|               |                   | Die Cast                     | Metal-Plated Plastic | With Slide Latch                 | Without Slide Latch |                         | Inner                               | Outer      | Die Set for Hand Tool 54334-1 | Applicator Die Set |
| 4             | .240<br>6.10      | 5745174-4                    | 5747100-7            | —                                | —                   | —                       | 7-745129-3                          | 3-745130-8 | 543013-3                      | 813809-1           |
|               | .280<br>7.11      | 5745174-4                    | 5747100-7            | —                                | —                   | —                       | 7-745129-8                          | 4-745130-5 | 1-543013-6                    | 813809-7           |
|               | .350<br>8.90      | 5745174-5                    | 5747100-9            | —                                | —                   | 745508-5                | —                                   | —          | —                             | —                  |
|               | .350<br>8.90      | 5745174-4                    | 5747100-7            | —                                | —                   | —                       | 7-745129-2                          | 3-745130-9 | 543013-4                      | 813809-2           |
|               | .430<br>10.92     | 5745174-4                    | 5747100-7            | —                                | —                   | 745508-1                | 7-745129-1                          | 4-745130-1 | 543013-7                      | 813809-3           |
|               | .500<br>12.70     | 5745174-3                    | —                    | —                                | —                   | 745508-8                | —                                   | —          | —                             | —                  |
|               | .525<br>13.34     | 5745174-1                    | 5747100-1            | —                                | —                   | —                       | 7-745129-6                          | 4-745130-2 | 1-543013-1                    | 813809-4           |
|               | .575<br>14.61     | 5745174-2                    | 5747100-3            | —                                | —                   | 1-745508-0              | —                                   | —          | —                             | —                  |
|               | .650<br>16.51     | 5745174-1                    | 5747100-1            | —                                | —                   | 1-745508-1              | —                                   | —          | —                             | —                  |
|               | 5                 | .240<br>6.10                 | 5745175-6            | —                                | —                   | —                       | —                                   | 7-745129-0 | 3-745130-8                    | 543013-2           |
| .365<br>9.27  |                   | 5745175-6                    | —                    | —                                | —                   | —                       | 6-745129-9                          | 4-745130-0 | 543013-6                      | 813809-5           |
| .375<br>9.53  |                   | 5745175-6                    | —                    | —                                | —                   | 745508-6                | —                                   | —          | —                             | —                  |
| .430<br>10.92 |                   | 5745175-4                    | —                    | —                                | —                   | —                       | 7-745129-5                          | 4-745130-1 | 543013-8                      | 813809-3           |
| .450<br>11.43 |                   | 5745175-5                    | —                    | —                                | —                   | 745508-7                | —                                   | —          | —                             | —                  |
| .525<br>13.34 |                   | 5745175-4                    | —                    | —                                | —                   | 745508-9                | —                                   | —          | —                             | —                  |
| .530<br>13.46 |                   | 5745175-4                    | —                    | —                                | —                   | —                       | 7-745129-4                          | 4-745130-2 | 1-543013-0                    | 813809-4           |
| .600<br>15.24 |                   | 5745175-3                    | —                    | —                                | —                   | 1-745508-0              | —                                   | —          | —                             | —                  |
| .650<br>16.51 |                   | 5745175-1                    | 5747098-1            | —                                | —                   | —                       | 1-745508-1                          | 4-745130-3 | 1-543013-4                    | —                  |
| .675<br>17.15 |                   | 5745175-2                    | —                    | —                                | —                   | 1-745508-1              | —                                   | —          | —                             | —                  |
| .750<br>19.05 | 5745175-1         | 5747098-1                    | —                    | —                                | 1-745508-2          | —                       | —                                   | —          | —                             |                    |

\*For split-ring ferrules, Min. O.D. is .040 [1.02] smaller than Max. O.D.  
 \*\*For inner and outer ferrules, Min. O.D. is .050 [1.27] smaller than Max. O.D. At the Max. cable O.D. the Min. insulation thickness is .060 [1.52].  
**Note:** Refer to page 143 for Application Tooling for ferrules.

**Note:** All part numbers are RoHS compliant.

## Hardware

### Commoning Strip (for HDF-20 Plugs, Size 20 Pin Contacts)

**Material and Finish:**

Brass, .004 [0.10] thick, tin plated

**Part No. 206918-2**

(Continuous Strip)

**Related Product Data:**

Used with HDF-20 Plugs—  
page 126

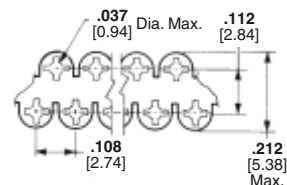
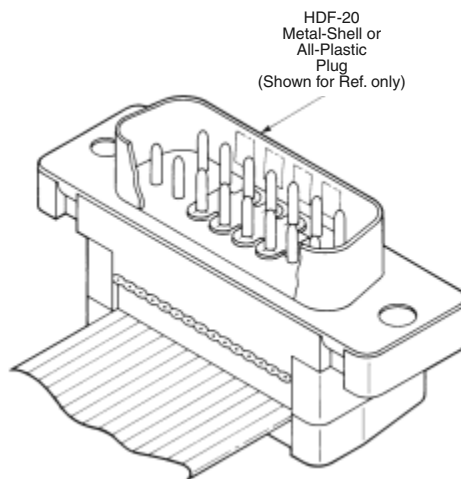

**Notes:**

1. Use punching tool to remove undesired pin commoning locations on commoning strip. Use mating receptacle to seat strip over pins in plug. Punching tool is not supplied by TE.
2. Sold in strip form, strip contains 10,000 commoning locations.

### Male Screw Retainers for Metal-Shell Connectors (HDE and HDP)

**Material and Finish:**

**Male Screw**—Steel, zinc plated clear or yellow chromate

**Retaining Clip**—.012 [0.31] stainless steel

**Related Product Data:**

**Connectors used with:**  
**HDE Metal-Shell**—pages 114 & 115  
**HDP Metal-Shell**—pages 90-102

**Technical Documents:**

**Instruction Sheet**—408-7837

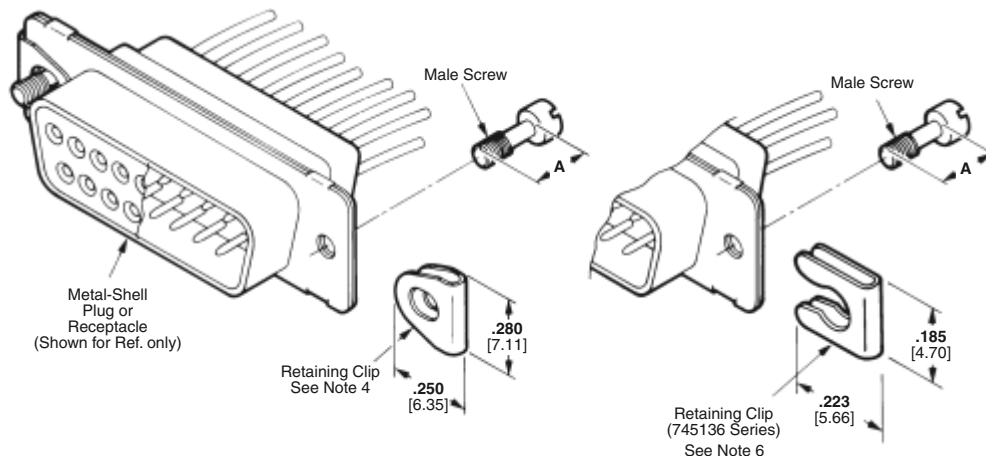

| Male Screw Finish | Thread Size | Dimension A  | Male Screw Retainer Kit No. |              |
|-------------------|-------------|--------------|-----------------------------|--------------|
|                   |             |              | Individual                  | Bulk Packed* |
| Yellow Chromate   | 4-40        | .220<br>5.59 | 5205980-1                   | 5205980-3    |
|                   |             | .200<br>5.08 | 5787354-1**                 | —            |
|                   | M3 (Metric) | .225<br>5.72 | 5745136-1                   | 5745136-2    |
|                   |             | .200<br>5.08 | 5207871-1                   | —            |
| Clear Chromate    | 4-40        | .220<br>5.59 | 5205980-4                   | 5205980-5    |
|                   |             | .200<br>5.08 | 5745136-3                   | 5745136-4    |

\*Each part is individually bulk packed for multiple kit orders.

\*\* Phillips Head Screw

- Notes:**
1. All parts are packaged unassembled.
  2. Each kit is comprised of two male screws and two retaining clips. Male screw retainers are also furnished as part of cable clamp kits (pages 137 and 138).
  3. Male screw retainers mate with female screwlocks (page 144), with HDF metal-shell connectors featuring 4-40 threaded inserts (page 148) and with HD metal-shell board mount connectors featuring 4-40 threaded inserts or female screwlocks.
  4. Retaining clip must be assembled onto connector flanges with threaded hole toward wire side of connector.
  5. All screws have straight slotted heads except where noted.
  6. Retaining clip must be assembled onto connector flanges with notched side of retainer toward mating side of connector.

**Note:** All part numbers are RoHS compliant.

**Hardware** (Continued)

**Material and Finish:**

**Male Screw**—Steel, zinc plated yellow chromate

**Retaining Clip**—.012 [0.51] stainless steel

**Related Product Data:**

**Connectors used with:**  
**HDE All-Plastic**—pages 112 & 113

**Technical Documents:**

**Instruction Sheet**—408-7837

**Male Screw Retainers for All-Plastic Connectors (HDE)**

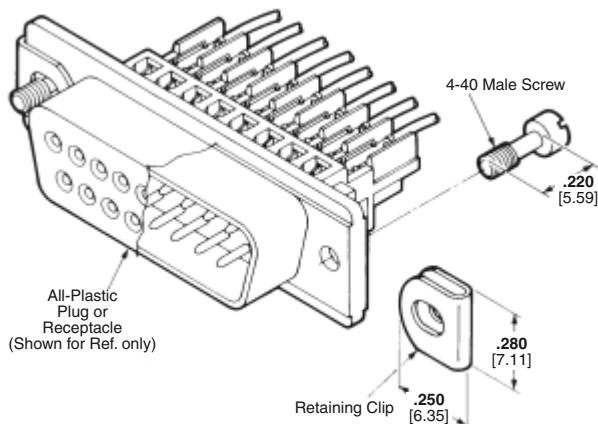

**Kit Numbers:**

**745647-1** (Individually packaged, see Note 2)

**745647-2** (Bulk packed)\*

\*Each part is individually bulk packed for multiple kit orders.

- Notes:**
1. All parts are packaged unassembled.
  2. Each kit is comprised of two 4-40 male screws and two retaining clips.
  3. Male screw retainers mate with female screwlocks (page 148), with HDF All-Plastic connectors featuring 4-40 threaded inserts (page 125), with HD All-Plastic board mount connectors featuring integral standoffs with 4-40 threaded inserts and female screwlocks.
  4. Retaining clips must be assembled onto connector flanges with threaded hole toward wire side of connector.

**Material and Finish:**

**Male Screw**—Steel, zinc plated clear chromate

**Retaining Clip**—.012 [0.51] stainless steel

**Related Product Data:**

**Connectors used with:**  
**HDF Metal-Shell and All-Plastic**—pages 125 & 126

**Technical Documents:**

**Instruction Sheet**—408-7837

**Male Screw Retainers for Metal-Shell and All-Plastic Connectors (HDF)**

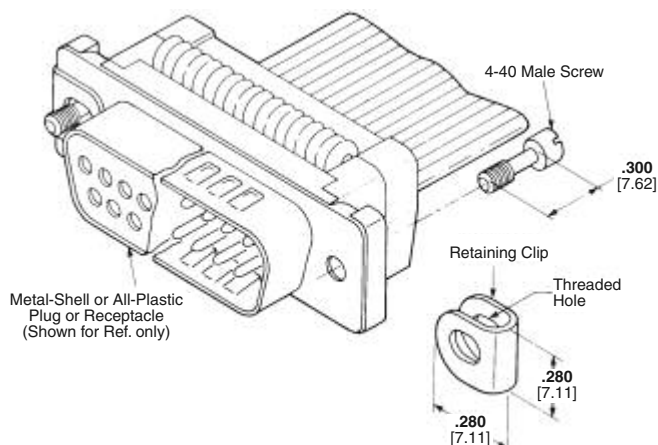

**Kit Numbers:**

**746881-1** (Individually packaged, see Note 2)

**746881-2** (Bulk packed)\*

\*Each part is individually bulk packed for multiple kit orders.

- Notes:**
1. All parts are packaged unassembled.
  2. Each kit is comprised of two male screws and two retaining clips.
  3. Male screw retainers mate with female screwlocks (page 148), and with HD board mount connectors featuring female screwlocks.
  4. Retaining clips must be assembled onto connector flanges with threaded hole toward wire side of connector.

**Note:** All part numbers are RoHS compliant.

**Hardware** (Continued)

**Material and Finish:**

**All Parts**—Cold rolled steel, zinc plated clear or yellow chromate

**Related Product Data:**

**Connectors used with:**  
**HDE Metal-Shell or All-Plastic**—pages 112-115  
**HDF Metal-Shell or All-Plastic**—pages 125 & 126  
**HDP Metal-Shell**—pages 90-102  
**HD Board Mount**—pages 54-71, 78-85, 87-89

**Technical Documents:**

**Instruction Sheet**—408-7837

**Female Screwlocks for Metal-Shell and All-Plastic Connectors (HDE, HDF, HDP)**

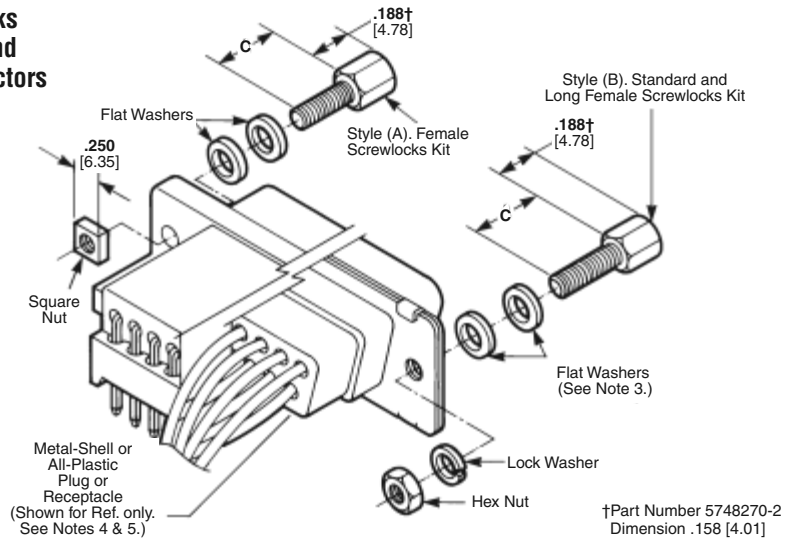

| Connector Used with   | Style | Dimension C   | Thread Size | Finish          | Kit Number |                          |
|---|-------|---------------|-------------|-----------------|------------|--------------------------|
|   |       |               |             |                 | Individual | Bulk Packed <sup>Δ</sup> |
| HD All-Plastic Right-Angle Plugs and Receptacles                    | (A)   | .250<br>6.35  | 4-40        | Yellow Chromate | 5207952-1  | —                        |
|   |       |               |             | Clear Chromate  | 5207952-3  | —                        |
| HDE Metal-Shell or All-Plastic Plugs and Receptacles                | (B)   | .250<br>6.35  | 4-40        | Yellow Chromate | 5745563-1  | 5745563-1                |
|   |       |               |             | Clear Chromate  | 5745563-3  | 5745563-4                |
| HDP or HDF Metal-Shell or All-Plastic Plugs and Receptacles         | (B)   | .312<br>7.93  | 4-40        | Yellow Chromate | 5205817-1  | 5205817-2                |
|   |       |               |             | Clear Chromate  | 5205817-3  | 5205817-4                |
|   |       |               | M3 (Metric) | Yellow Chromate | 5207872-1  | —                        |
|   |       |               |             | Clear Chromate  | 5207872-3  | —                        |
| HD or HDF All-Plastic Plugs and Receptacles with Integral Standoffs | (B)   | .560<br>14.22 | 4-40        | Yellow Chromate | 5207719-1  | 5207719-2                |
|   |       |               |             | Clear Chromate  | 5207719-3  | 5207719-4                |
|   |       |               | 2-56*       | Clear Chromate  | 5747223-3  | —                        |

\* 2-56 is the male thread size. The female thread size is 4-40.

<sup>Δ</sup> Each part is individually bulk packed for multiple kit orders.

**Notes:** 1. All parts are packaged unassembled.

2. Each female screwlock kit is comprised of two assemblies as illustrated above.

3. One or two flat washers may be required for panel thicknesses less than .060 [1.52]. Female screwlocks are not recommended for panel thicknesses greater than .060 [1.52].

4. Female screwlocks with 2-56 thread size are to be used with cable clamps with mounting flanges. Female screwlocks with 4-40 and M3 (Metric) thread sizes can be used with all other cable clamps.

5. Female screwlocks mate with male screw retainers (pages 146 and 147).

6. Short female screwlocks cannot be used with HDF connectors (pages 125 & 126)

**Individual Screwlocks**

(Washers and Nuts not included)

| Connector Used with   | Style        | Dimension C  | Thread Size                 | Finish                     | Screwlocks     |                          |
|---|--------------|--------------|-----------------------------|----------------------------|----------------|--------------------------|
|   |              |              |                             |                            | Individual     | Bulk Packed <sup>Δ</sup> |
| HD All-Plastic Right-Angle Plugs and Receptacles            | (A)          | .250<br>6.35 | 4-40                        | Yellow Chromate            | 5207953-2      | —                        |
|   |              |              |                             | Clear Chromate             | 5207953-3      | —                        |
|   |              |              |                             | Clear Chromate             | —              | 5205818-3 <sup>**</sup>  |
| HDP or HDF Metal-Shell or All-Plastic Plugs and Receptacles | (B)          | .312<br>7.93 | 4-40                        | Clear Chromate             | 5748558-3      | 5748558-4                |
|   |              |              |                             | Yellow Chromate            | 5748270-2      | 5205818-2 <sup>**</sup>  |
|   |              |              | M2.6 <sup>**</sup> (Metric) | Clear Chromate             | 5749765-3      | —                        |
|   |              |              |                             | M3 <sup>***</sup> (Metric) | Clear Chromate | 5747404-3                |
| (Special)   | .185<br>4.70 | 4-40         | Clear Chromate              | 5747877-3                  | —              |                          |

<sup>Δ</sup> Each part is individually bulk packed for multiple kit orders.

<sup>ΔΔ</sup>With captivated star washer. No additional hardware included.

†Part No. 5748270-2 Dimension .158 [4.01]

\*\*M2.6 is the female thread size. The male thread size is 4-40.

\*\*\*M3 is the female thread size. The male thread size is 4-40.

**Note:** All part numbers are RoHS compliant.



**Nut Driver, Part No. 811262-1**

(Used for assembling female screwlocks to connector flange)



**Hardware** (Continued)

**Slide Latches**

**Material and Finish:**

**4-40 Screws, Washers and Hex Nuts**—Steel, zinc plated yellow chromate

**2-56 Screws, Washers and Hex Nuts**—Steel, zinc plated clear chromate

**Slide Latch**—Stainless steel

**Related Product Data:**

**Connectors used with:**

**HDE Metal-Shell or All-Plastic**—pages 112-115

**HDF Metal-Shell or All-Plastic**—pages 125 & 126

**HDP Metal-Shell**—pages 90-102

**HD Board Mount**—pages 54-71, 78-85, 87-89

**Technical Documents:**

**Instruction Sheet**—408-6551

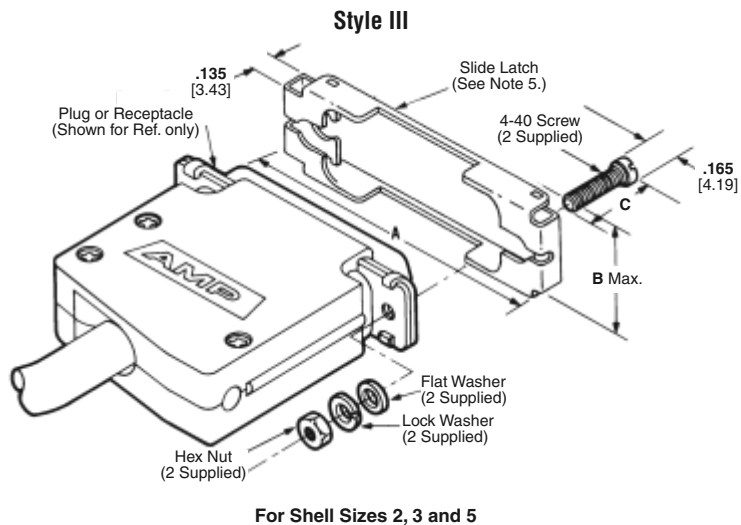
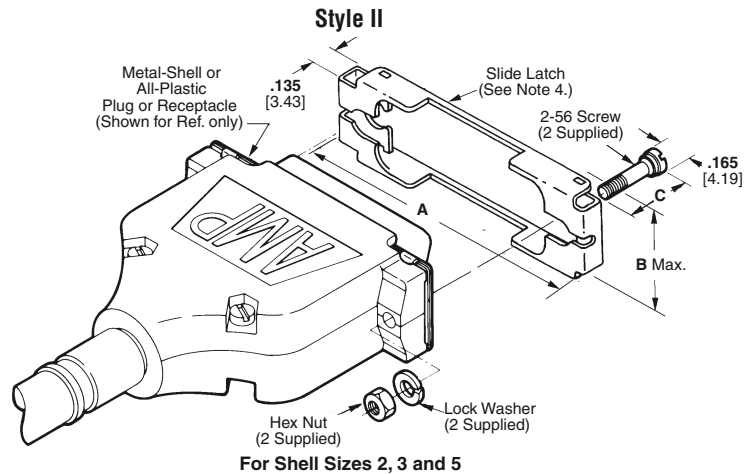
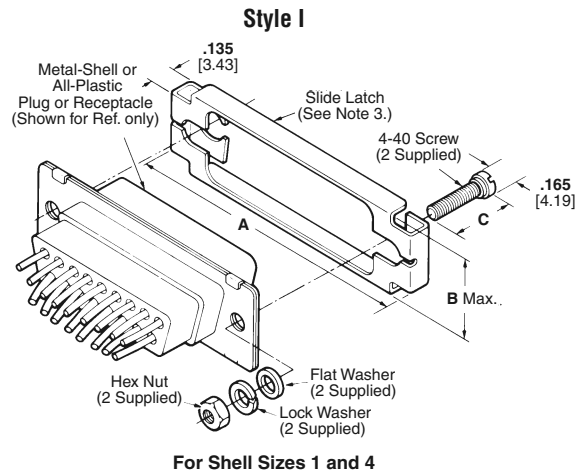

**Hardware** (Continued)

**Slide Latches**

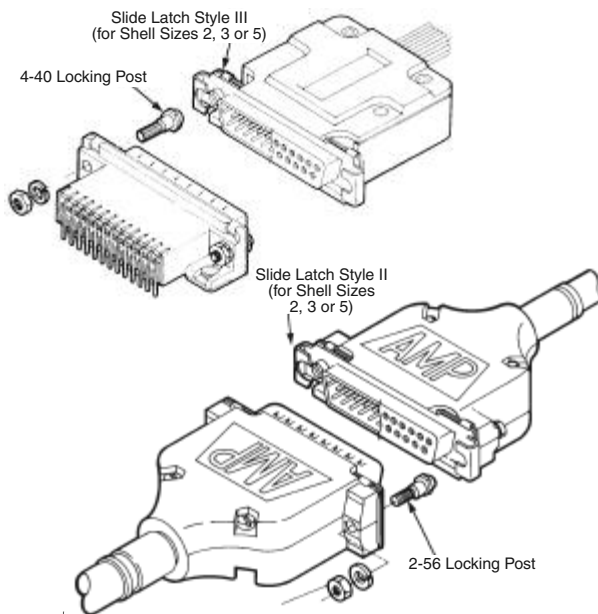

Typical Applications of Locking Posts and Slide Latches

| Shell Size | Style | Dimensions     |                |               | Slide Latch Kit Numbers |                        | Side Latch Only |
|------------|-------|----------------|----------------|---------------|-------------------------|------------------------|-----------------|
|            |       | A              | B              | C             | Individual              | Bulk Packed*           |                 |
| 1          | I     | 1.397<br>35.48 | .490<br>12.45  | .415<br>10.54 | 5745404-1               | —                      | 164890-1        |
|            | II    | 1.725<br>43.82 | .470<br>11.94  | .547<br>13.89 | 5745583-1               | —                      | 749027-1        |
| 2          | II    | 1.725<br>43.82 | .470<br>11.94  | .415<br>10.54 | 5745583-5               | —                      | 749027-1        |
|            |       | 1.725<br>43.82 | .470<br>11.94  | .450<br>11.43 | 5745583-7               | —                      | —               |
|            | III   | 1.725<br>43.82 | .470<br>11.94  | .415<br>10.54 | —                       | 5748653-1              | —               |
|            |       | 1.725<br>43.82 | .490<br>12.45  | .290<br>7.37  | 5749028-1 <sup>7</sup>  | —                      | —               |
|            | III   | 1.725<br>43.82 | .437<br>11.10  | .415<br>10.54 | —                       | 5786138-1 <sup>7</sup> | —               |
|            |       | II             | 2.265<br>57.53 | .470<br>11.94 | .547<br>13.89           | 5745584-1              | —               |
| 3          | III   | 2.265<br>57.53 | .470<br>11.94  | .415<br>10.54 | 5745584-3               | —                      | 749996-1        |
|            | I     | 2.913<br>73.99 | .490<br>12.45  | .415<br>10.54 | 5745407-1               | —                      | 164890-4        |
| 5          | III   | 2.819<br>71.60 | .575<br>14.61  | .415<br>10.54 | 5745578-3               | —                      | 749997-1        |

\*Each part is individually bulk packed for multiple kit orders.

- Notes:**
1. All parts are packaged unassembled.
  2. Each kit is comprised of a slide latch and two screws, flat washers (if required), lock washers and hex nuts. Style I slide latches are also furnished as part of cable clamp kits (page 142).
  3. Style I slide latches can be used with cable clamps that do not extend beyond the front flange of the connector or on connectors without cable clamps.
  4. Style II slide latches can be used with any cable clamp that has the mounting ear configuration as shown above.
  5. Style III slide latches can be used on connectors without cable clamps or with cable clamps that do not have the mounting ear configuration shown with Style II above.
  6. Slide latches mate with locking posts (page 151).
  7. No nuts, washers, or lockwashers.

**Note:** All part numbers are RoHS compliant.

**Hardware** (Continued)

**Slide Latch Clip Assembly for Unfiltered Mating Half**

**Material and Finish:**

**Screw, Washers and Hex Nut**—Cold rolled steel, zinc plated clear chromate  
**Clip**—Stainless steel

**Technical Documents:**

**Instruction Sheet**—408-7785

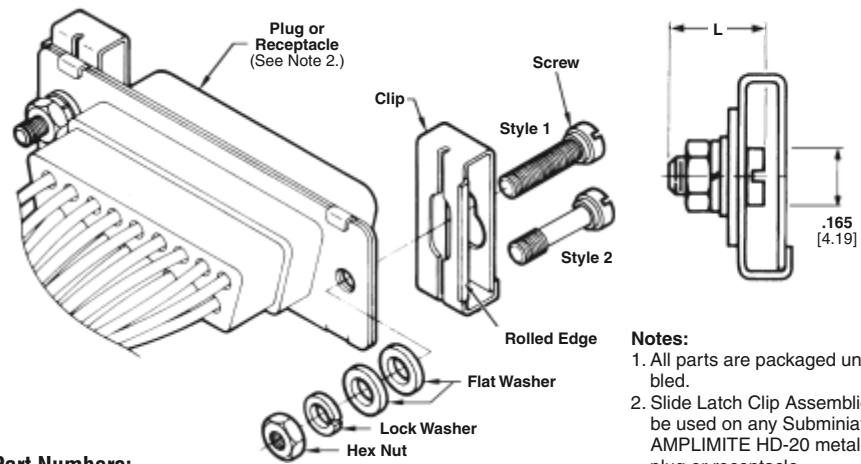

**Notes:**

1. All parts are packaged unassembled.
2. Slide Latch Clip Assemblies can be used on any Subminiature D AMPLIMITE HD-20 metal-shell plug or receptacle.
3. Slide Latch Clip Assemblies mate with Locking Post Assemblies shown below.

**Kit Part Numbers:**

| Thread Size | Screw Length<br>L | Pkg.  | Screw Style | Part No.    |
|-------------|-------------------|-------|-------------|-------------|
| 4-40        | .415              | Unit† | 1           | 5206942-1   |
|             | 10.54             | Bulk  |             | 5206942-2   |
| 2-56        | .547              | Unit  | 2           | 5748078-1** |
|             | 13.89             | —     |             | —           |

† Two assemblies per package.

\* Each part is individually bulk packed for multiple kit orders.

\*\* Designed for cable clamps with mounting ears. No flat washers included.

**Locking Post Assembly**

**Material and Finish:**

**All Parts**—Cold rolled steel, zinc plated clear or yellow chromate

**Related Product Data:**

**Connectors used with:**  
**HDE Metal-Shell or All-Plastic**—pages 112-115  
**HDF Metal-Shell or All-Plastic**—pages 125 & 126  
**HDP Metal-Shell**—pages 90-102  
**HD Board Mount**—pages 54-71, 78-85, 87-89  
**Instruction Sheets**—  
 408-6551  
 408-7785

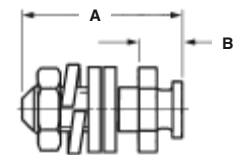
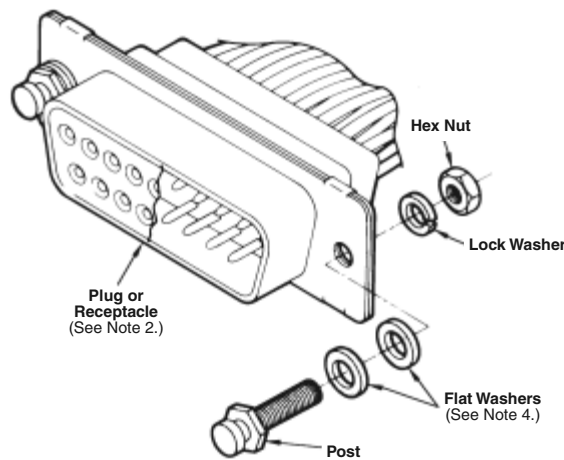

**Part No. 206514-1**

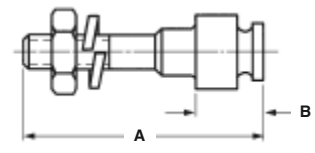

**Part No. 747242-1**

**Notes:**

1. All parts are packaged unassembled.
2. Each kit is comprised of two complete assemblies, as illustrated above.
3. For front panel mounting, it is recommended that a shim be used between the connector flange and panel to prevent bowing of the flange.
4. Locking posts with 2-56 thread size are to be used with cable clamps with mounting flanges. Locking posts with 4-40 thread size can be used with all other cable clamps
5. Locking posts mate with slide latches (page 149).

| Thread Size | Locking Post Finish | Dimensions |      | Locking Post Kit Number (See Note 4) |              |
|-------------|---------------------|------------|------|--------------------------------------|--------------|
|             |                     | A          | B    | Individual                           | Bulk Packed* |
| 4-40        | Yellow Chromate     | .410       | .110 | 5206514-1                            | 5206514-3    |
|             | Clear Chromate      | .410       | .110 | 5206514-4                            | —            |
|             | Yellow Chromate     | 10.41      | 2.79 | 5206514-6                            | 5206514-7    |
| 2-56        | Yellow Chromate     | .560       | .110 | 5747242-1                            | —            |
|             | Yellow Chromate     | 14.22      | 2.79 | —                                    | —            |

\*Each part is individually bulk packed for multiple kit orders.

**Note:** All part numbers are RoHS compliant.

**Hardware** (Continued)

**Material**

.015 [0.38] Stainless steel

**Related Product Data:**

**Connectors used with:**  
**HDE Metal-Shell**—pages 114 & 115  
**HDP Metal-Shell (Tin plated only)**—pages 90-102

**Technical Documents:**

**Instruction Sheet**—408-9130

**Spring Latches for Cable Clamps with Mounting Ears (Two-Piece)**

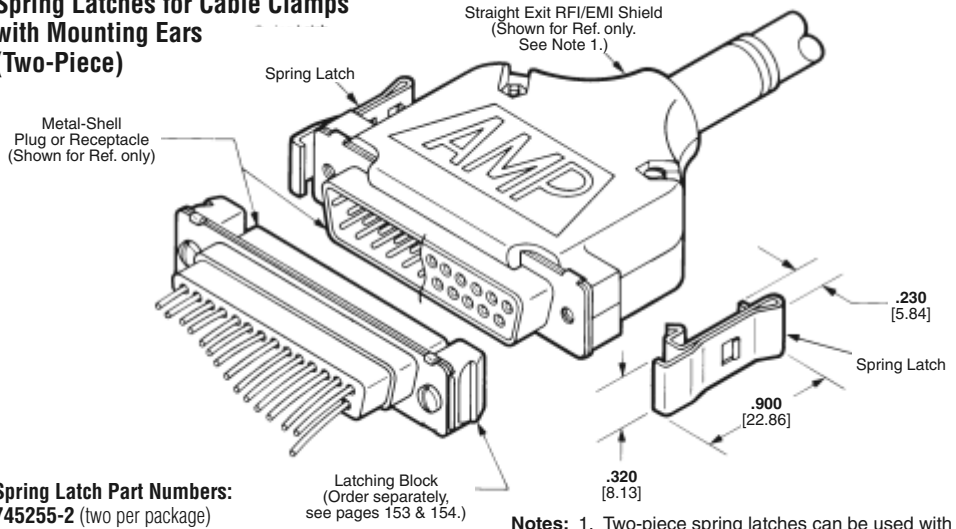

**Spring Latch Part Numbers:**  
**745255-2** (two per package)  
**745255-3** (bulk packed)\*

\*Two-piece spring latches are individually bulk packed for multiple part orders.

- Notes:**
1. Two-piece spring latches can be used with RFI/EMI shields (pages 141).
  2. Two-piece spring latches mate with latching blocks (pages 153 & 154).

**Typical Application of Two-Piece Spring Latches with Straight Exit RFI/EMI Shield**

**Spring Latches (Two-Piece)**

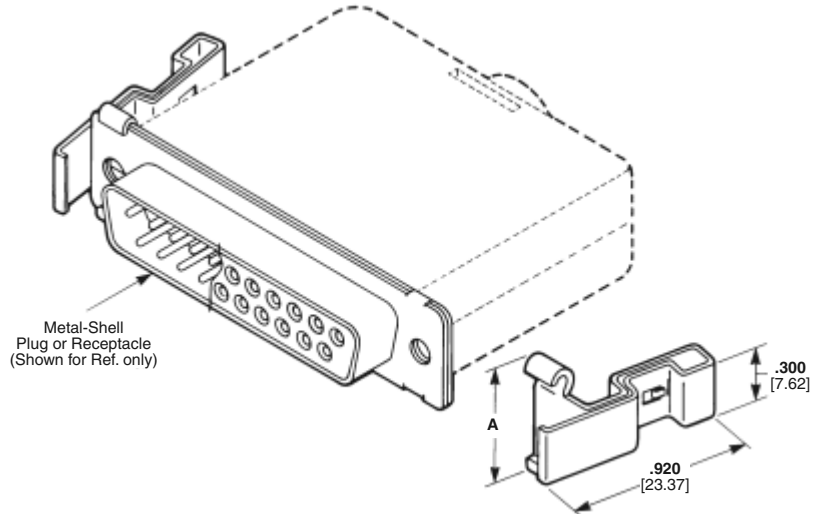

**Material:**

Stainless steel

**Related Product Data:**

**Connectors used with:**  
**HDE Metal-Shell**—pages 114 & 115  
**HDP Metal-Shell**—pages 90-102

**Technical Documents:**

**Instruction Sheet**—408-9131

**Spring Latch Part Numbers**

| Size | Dimension A   | Two Per Package | Bulk Packed* |
|------|---------------|-----------------|--------------|
| 1-4  | .540<br>13.72 | 745779-2        | 745779-3     |
| 5    | .650<br>16.51 | 745779-5        | —            |

\*Two-piece spring latches are individually bulk packed for multiple part orders.

- Notes:**
1. These dimensions must be maintained to assure satisfactory operation of the spring latches.
  2. Two-piece spring latches mate with latching blocks (pages 153 & 154).

**Note:** All part numbers are RoHS compliant.

**Typical Application of Two-Piece Spring Latches with Post Molded Strain Relief**

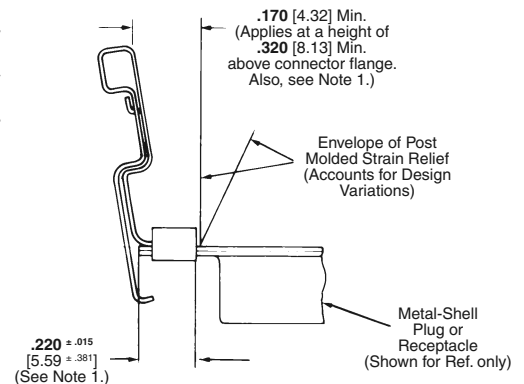

## Hardware (Continued)

**Material and Finish:**  
**Latching Blocks**—Zinc  
**Pan Head Screws**—Steel, zinc plated

**Related Product Data:**  
**Connectors used with:**  
**HDE Metal-Shell or All-Plastic**—  
 pages 112-115  
**HDF Metal-Shell or All-Plastic**—  
 pages 125 & 126  
**HDP Metal-Shell**—pages 90-102  
**HD Board Mount**—pages 54-71,  
 78-85, 87-89  
**Mating/Panel Mounting**—page 136

**Technical Documents:**  
**Instruction Sheet**—408-9128

### Latching Blocks with Threaded Hole

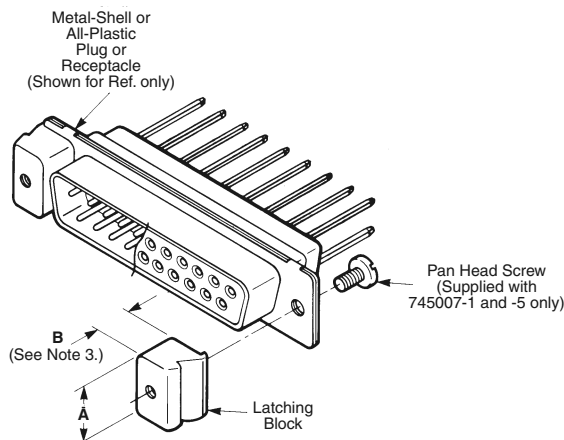

| Shell<br>(No. of<br>Contact<br>Pos.) | Dimensions    |              | Panel<br>Thickness | Thread<br>Size | Rear-Panel Latching Block<br>Part No. |              | Front-Panel Latching Block<br>Part No. |              |
|--------------------------------------|---------------|--------------|--------------------|----------------|---------------------------------------|--------------|--|--------------|
|                                      | A             | B            |                    |                | Individual                            | Bulk Packed* | Individual                             | Bulk Packed* |
| 1 thru 4<br>(9 thru 37)              | .400<br>10.16 | .190<br>4.83 | .060<br>1.52       | M3<br>(Metric) | —                                     | 745403-2     | —                                      | —            |
|                                      |               |              |                    | 4-40           | 745403-8                              | —            | —                                      |              |
|                                      | .400<br>10.16 | .220<br>5.59 | .030<br>0.76       | 4-40           | 747717-2                              | —            | —                                      |              |
|                                      |               |              |                    | —              | —                                     | —            | —                                      |              |
| 5<br>(50)                            | .400<br>10.16 | .250<br>6.35 | —                  | M3<br>(Metric) | —                                     | —            | 5745007-1                              | —            |
|                                      |               |              |                    | 4-40           | —                                     | —            | 208101-1                               | 208101-2     |
|                                      | .530<br>13.46 | .250<br>6.35 | —                  | 4-40           | —                                     | —            | 208101-8                               | 208101-9     |
|                                      |               |              |                    | —              | —                                     | —            | 1-208101-1                             | —            |

\*Bulk packed for multiple part orders.  
 \*\*Individual kits contain two latching blocks per package.

- Notes:**
1. All parts are packaged unassembled.
  2. Each front panel latching block kit is comprised of two latching blocks. Two pan head screws of the appropriate length and thread size to be supplied by customer.
  3. B dimension .250 [6.35] is for connector flange mounting, .220 [5.59] is for use with .030 [0.76] thick panels, and .190 [4.83] is for use with .060 [1.52] thick panels.
  4. Latching blocks mate with spring latches (page 152).

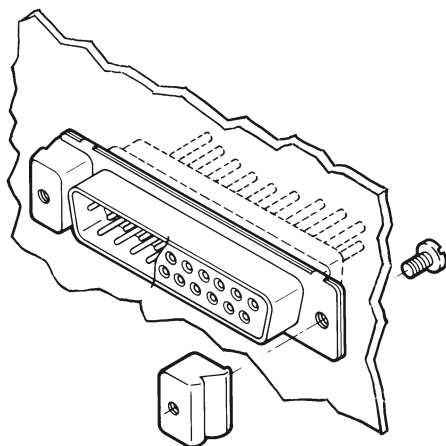

Typical Application of Front-Panel Mounted  
 Subminiature D Connector using Front-Panel Latching Blocks

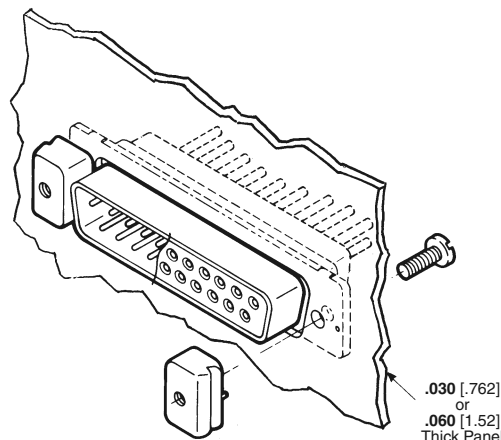

Typical Application of Rear-Panel Mounted  
 Subminiature D Connector using Rear-Panel Latching Blocks

**Note:** All part numbers are RoHS compliant.

**Hardware** (Continued)

**Material**

Latching Blocks—Zinc

**Related Product Data:**

- Connectors used with:**
- HDE Metal-Shell or All-Plastic**—pages 112-115
- HDF Metal-Shell or All-Plastic**—pages 125 & 126
- HDP Metal-Shell**—pages 90-102
- HD Board Mount**—pages 54-71, 78-85, 87-89
- Mating/Panel Mounting**—page 136

**Technical Documents:**

Instruction Sheet—408-9128

**Latching Blocks with Slot Recess and Thru Hole**

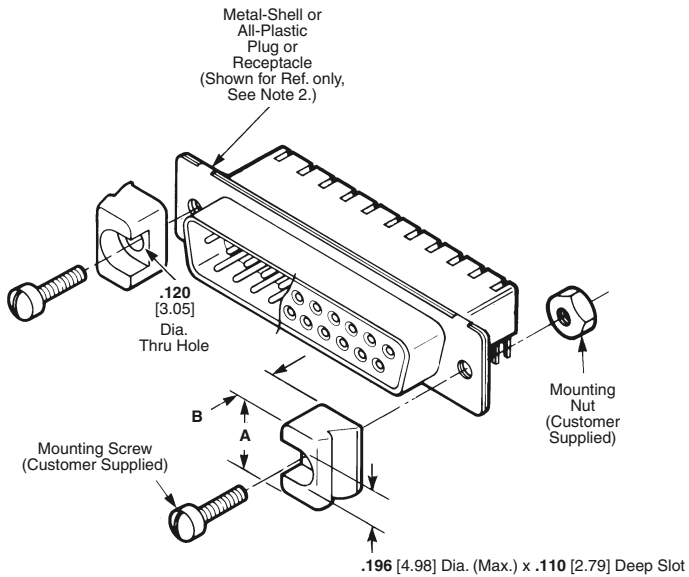

| Shell (No. of Contact Pos.) | Dimensions    |              | Panel Thickness | Rear-Panel Latching Block Part No. |              | Front-Panel Latching Block Part No. |
|-----------------------------|---------------|--------------|-----------------|------------------------------------|--------------|-------------------------------------|
|                             | A             | B            |                 | Individual                         | Bulk Packed* | Individual                          |
| 1 thru 4<br>(9 thru 37)     | .400<br>10.16 | .160<br>4.06 | .090<br>2.29    | 747080-2                           | —            | —                                   |
|                             |               | .190<br>4.83 | .060<br>1.52    | 745245-2                           | 745245-3     | —                                   |
|                             |               | .250<br>6.35 | —               | —                                  | —            | 745286-2                            |
| 5<br>(50)                   | .530<br>13.46 | .190<br>4.83 | .060<br>1.52    | —                                  | —            | 745245-5                            |

\*Bulk packed for multiple part orders.

\*\*Individual kits contain two latching blocks per package.

- Notes:**
1. Mounting screws and nuts are to be supplied by Customer.
  2. These latching blocks allow mounting screws to be installed thru the front of the block and to be screwed into the bracket of a right-angle connector, a fixed insert in a connector mounting flange, or a nut behind the connector mounting flange (as illustrated above).
  3. Latching blocks mate with spring latches (page 152).

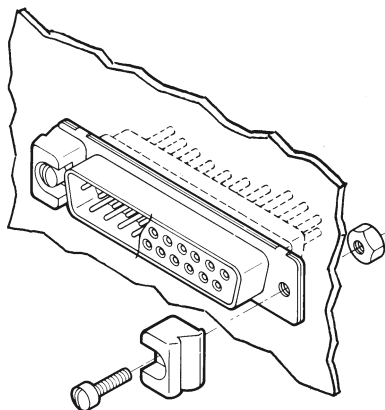

**Typical Application of Front-Panel Mounted Subminiature D Connector using Front-Panel Latching Blocks**

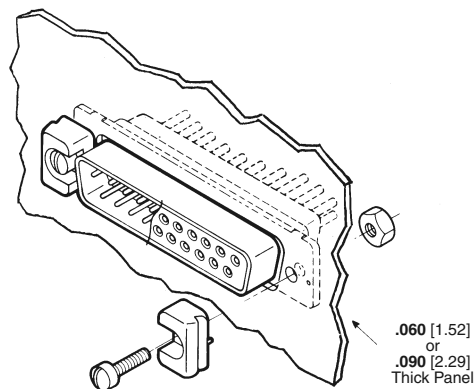

**Typical Application of Rear-Panel Mounted Subminiature D Connector using Rear-Panel Latching Blocks**

**Note:** All part numbers are RoHS compliant.



**Hardware** (Continued)

**Standoff Bushings**

**Material:**

Aluminum

**Related Product Data:**

**Connectors used with:**  
**HD Straight Posted**—  
 pages 76-85, 87-89

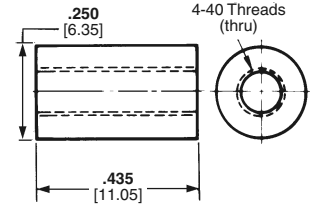
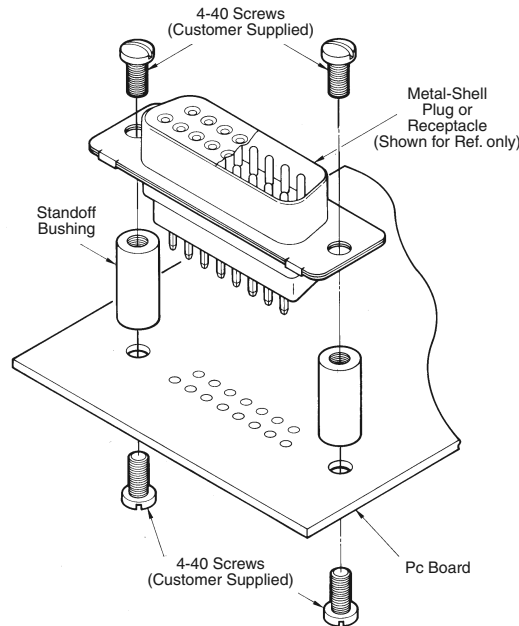

**Kit Numbers:**

**205933-3** (two bushings per package)

**205933-4** (bulk packed)\*

\*Parts are individually bulk packed for multiple part orders.

**Keying Plug**  
 (for Size 20 Socket Contacts)

**Material:**

Polyphenylene oxide

**Related Product Data:**

**Connectors used with:**  
**All HDE, HDP and HD Receptacles**  
 with Socket Contacts

**Keying Plug**

**499712-1 AMP-LATCH** (electrical connectors) can be used on **HD22 Socket Contacts**

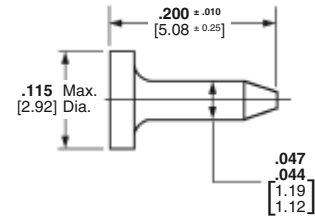
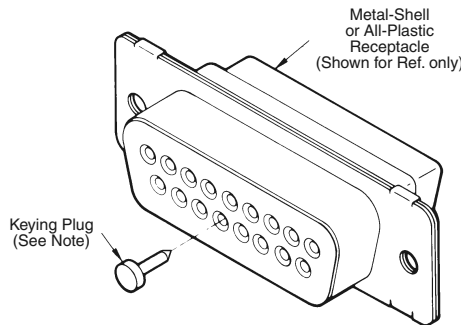

**Part Number: 206509-1**

- Notes:**
1. Keying plug is installed taper-end first into front of receptacle.
  2. Sold individually.

**EMI/RFI Gaskets**

**Material and Finish:**

Brass, .006 [0.15] thick; bright tin plated

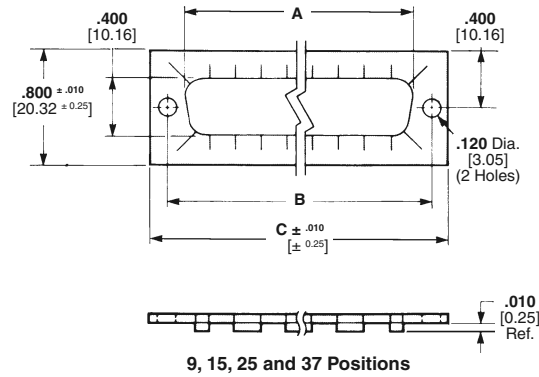

| Shell Size<br>(No. of Contact Pos.) | Dimensions     |                |                | Gasket Part No. |
|-------------------------------------|----------------|----------------|----------------|-----------------|
|                                     | A              | B              | C              |                 |
| 1<br>(9)                            | .746<br>18.95  | .984<br>24.99  | 1.220<br>30.99 | 5747024-3       |
| 2<br>(15)                           | 1.074<br>27.28 | 1.312<br>33.32 | 1.555<br>39.50 | 5747025-3       |
| 3<br>(25)                           | 1.614<br>41.00 | 1.852<br>47.04 | 2.100<br>53.34 | 745776-4        |
| 4<br>(37)                           | 2.266<br>57.56 | 2.500<br>63.50 | 2.730<br>69.34 | 745777-4        |

**Note:** All part numbers are RoHS compliant.



Компания «ЭлектроПласт» предлагает заключение долгосрочных отношений при поставках импортных электронных компонентов на взаимовыгодных условиях!

Наши преимущества:

- Оперативные поставки широкого спектра электронных компонентов отечественного и импортного производства напрямую от производителей и с крупнейших мировых складов;
- Поставка более 17-ти миллионов наименований электронных компонентов;
- Поставка сложных, дефицитных, либо снятых с производства позиций;
- Оперативные сроки поставки под заказ (от 5 рабочих дней);
- Экспресс доставка в любую точку России;
- Техническая поддержка проекта, помощь в подборе аналогов, поставка прототипов;
- Система менеджмента качества сертифицирована по Международному стандарту ISO 9001;
- Лицензия ФСБ на осуществление работ с использованием сведений, составляющих государственную тайну;
- Поставка специализированных компонентов (Xilinx, Altera, Analog Devices, Intersil, Interpoint, Microsemi, Aeroflex, Peregrine, Syfer, Eurofarad, Texas Instrument, Miteq, Cobham, E2V, MA-COM, Hittite, Mini-Circuits, General Dynamics и др.);

Помимо этого, одним из направлений компании «ЭлектроПласт» является направление «Источники питания». Мы предлагаем Вам помощь Конструкторского отдела:

- Подбор оптимального решения, техническое обоснование при выборе компонента;
- Подбор аналогов;
- Консультации по применению компонента;
- Поставка образцов и прототипов;
- Техническая поддержка проекта;
- Защита от снятия компонента с производства.



#### Как с нами связаться

**Телефон:** 8 (812) 309 58 32 (многоканальный)

**Факс:** 8 (812) 320-02-42

**Электронная почта:** [org@eplast1.ru](mailto:org@eplast1.ru)

**Адрес:** 198099, г. Санкт-Петербург, ул. Калинина, дом 2, корпус 4, литера А.