



IQS316 Datasheet

IQ Switch[®] - ProxSense[®] Series

Multi-channel Capacitive Sensing Controller with Advanced Signal Processing Functions

The IQS316 is a 20 channel surface capacitive touch and proximity controller with advanced on-chip signal processing features, including Antenna Tuning Implementation (ATI). Proximity detection can be distributed over all keys, or only selected keys, providing high flexibility for stable operation in varying designs. The controller is based on patented capacitive sensing technology that yields stability with high sensitivity and excellent noise immunity. This controller can operate with a small number of external components to provide a low cost solution for medium to high channel count applications.

Main Features

- 16 Touch Keys with distributed Proximity Sensing
- Internal Capacitor Implementation (ICI). No external reference capacitors required
- Class leading proximity sensitivity with dedicated Prox Mode charging scheme
- User selectable gain through Antenna Tuning Implementation (ATI)
- All channels individually configurable for maximum design flexibility
- Advanced on-chip signal processing
- User selectable I²C and SPI communication
- High sensitivity
- Internal voltage regulator
- Supply voltage 2.85V-5.5V
- Low power modes (45uA)
- Active shield options
- RF detection
- Available in QFN(5x5)-32 package
- 8 General Purpose I/O's

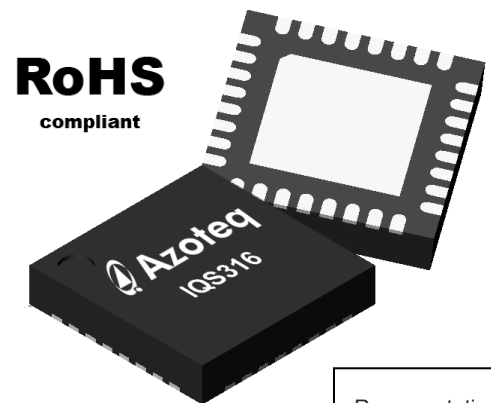

Representation only, not actual marking

Applications

- | | |
|--|--|
| <input type="checkbox"/> Office machines | <input type="checkbox"/> Consumer Electronics |
| <input type="checkbox"/> Digital cameras | <input type="checkbox"/> White goods and appliances |
| <input type="checkbox"/> Keypads | <input type="checkbox"/> Kiosk and POS Terminals |
| <input type="checkbox"/> High-end kitchen appliances | <input type="checkbox"/> Launch a menu on user approaching |
| <input type="checkbox"/> Personal Media Players | |

Available options

T_A	QFN32
-40°C to 85°C	IQS316



Contents

IQS316 Datasheet	1	5.2.2 Cx Sensors Requiring Shield	12
1 Overview	3	5.2.3 Cx Sensors Used For Prox.....	12
2 Packaging and Pin-out	4	5.2.4 Cx Sensors plus I/O's.....	13
2.1 QFN32.....	4	5.2.5 Unused Cx's.....	13
2.2 ICTRL.....	5	6 Communication	13
3 ProxSense[®] Module	5	6.1 Communication Selection.....	13
3.1 Charge Transfer Concepts	5	6.2 Watchdog Timeout and MCLR	13
3.2 Charging Modes	6	6.3 SPI.....	13
3.2.1 Prox Mode Charging	6	6.3.1 SPI read	14
3.2.2 Touch Mode Charging	6	6.3.2 SPI write	14
3.2.3 Interaction Between Prox and Touch Mode	7	6.3.3 SPI Communications Window Terminate	15
3.2.4 Low Power Charging	7	Command.....	15
3.3 Prox Module Setup	8	6.4 I ² C.....	15
3.3.1 Report rate.....	8	6.4.1 Control byte and Device Address.....	15
3.3.2 Transfer Frequency	8	6.4.2 I ² C read.....	15
3.3.3 Count Value.....	8	6.4.3 I ² C write	15
3.3.4 Prox Mode Channel Filters.....	8	6.4.4 I ² C Communications Window Terminate	16
3.3.5 Environmental Drift	8	Command.....	16
3.3.6 LTA Filter	8	6.5 Circuit diagrams (all features).....	16
3.3.7 Filter Halt	8	7 Electrical specifications	18
3.3.8 Touch Sensitivity (Touch Mode channels	9	7.1 Absolute maximum specifications.....	18
only)	9	7.2 Operating conditions (Measured at 25°C).....	18
3.3.9 Proximity Sensitivity (Prox and Touch Mode	9	7.3 Moisture Sensitivity Level.....	18
channels).....	9	7.4 Timing characteristics (Measured at 25°C)	19
3.3.10 Antenna Tuning Implementation	9	8 Mechanical Dimensions	20
4 Additional Features	10	8.1 IQS316 Mechanical Dimensions	20
4.1 RF Immunity	10	8.1.2 QFR package differences to QNR package.	21
4.1.1 Design Guidelines.....	10	8.2 IQS316 Landing Pad Layout.....	22
4.1.2 RF detection	10	9 Datasheet and Part-number Information	23
4.2 Active Shield	10	9.1 Ordering Information	23
4.3 Proximity Output (POUT).....	11	9.2 Package Marking.....	23
4.4 Zero Cross Synchronising	11	9.3 Tape and Reel.....	24
4.5 Device Sleep.....	11	9.5 Revision History.....	26
4.6 Communication Bypass	11	Appendix A. Contact Information	27
4.7 General Purpose I/O's	12		
5 Application Design	12		
5.1 Physical Layout	12		
5.2 Cx Selection	12		
5.2.1 Cx Sensor Close to Noise Source.....	12		



1 Overview

The IQS316 is a multi-key capacitive sensing controller designed for touch applications requiring up to 16 touch inputs. The device has proximity (PROX) detection integrated with the existing 16 touch sense electrode, providing a total of 4 additional PROX channel outputs.

The electrodes used for PROX are selectable, to allow keys in noisy/unreliable areas to not influence the PROX stability and sensitivity.

All 20 device channels (16 touch, 4 proximity) can be individually configured. It can be selected that 4, or 8 of the channels are setup to be used as general purpose I/O's. Functions such as simple LED control can be implemented with these I/O's.

The device has an internal voltage regulator and Internal Capacitor Implementation (ICI) to reduce external components required. Advanced on-chip signal processing capabilities and a dedicated PROX charging mode yields a stable capacitive controller with high sensitivity.

With the charge transfer method implemented,

each sensor (key) can be viewed as the positive plate of a capacitor and the environment as the negative plate (virtual ground reference). When a conductive object such as a human finger approaches the sensor, it will increase the detected capacitance.

Advanced signal processing is implemented to suppress and detect noise, track slow varying environmental conditions, and avoid effects of possible drift. The Antenna Tuning Implementation (ATI) allows for adapting to a wide range of application environments, without requiring external components.

The device provides active driven shields to protect the integrity of sensor line signals if required. The device has a high immunity to RF interference. For severe conditions, the RF detection pin allows for noise detection when connected to a suitable RF antenna, providing suppression of noise on the influenced data.

The IQS316 provides SPI and I²C communication options. A typical implementation of a 16 key touch panel is shown in Figure 1.1.

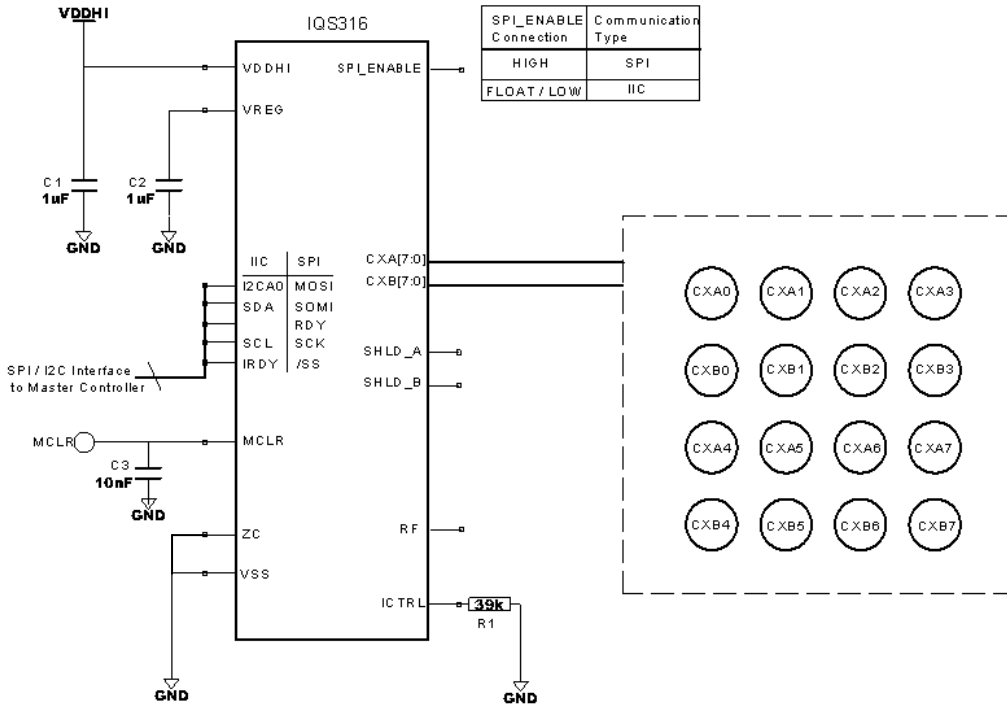

Figure 1.1 Typical implementation

2 Packaging and Pin-out

The IQS316 is available in a QFN32 package.

2.1 QFN32

The pin-out for the IQS316 in the QFN32 package is illustrated below in Figure 2.1.

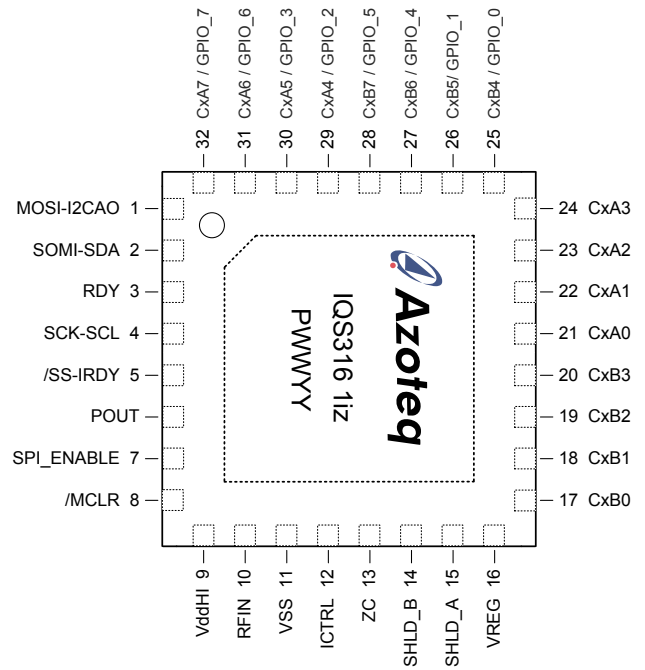

Figure 2.1 QFN32 Top View



Table 2.1 **QFN32 top view**

Pin	Name	Description
1	MOSI-I2CA0	Refer to Table 2.2
2	SOMI-SDA	Refer to Table 2.2
3	RDY	Refer to Table 2.2
4	SCK-SCL	Refer to Table 2.2
5	/SS-IRDY	Refer to Table 2.2
6	POUT	Proximity output
7	SPI_ENABLE	Comms Selection
8	/MCLR	Master Clear
9	VDDHI	Supply Voltage
10	RFIN	RF Noise Input
11	VSS	Ground Reference
12	ICTRL	Current Reference
13	ZC	ZC Input
14	SHLD_B	Shield
15	SHLD_A	Shield
16	VREG	Internal Regulator Voltage
17	CxB0	Cx Sensor Line
18	CxB1	Cx Sensor Line
19	CxB2	Cx Sensor Line
20	CxB3	Cx Sensor Line
21	CxA0	Cx Sensor Line
22	CxA1	Cx Sensor Line
23	CxA2	Cx Sensor Line
24	CxA3	Cx Sensor Line
25	CxB4 / GPIO_0	Cx Sensor Line / I/O
26	CxB5 / GPIO_1	Cx Sensor Line / I/O
27	CxB6 / GPIO_4	Cx Sensor Line / I/O
28	CxB7 / GPIO_5	Cx Sensor Line / I/O
29	CxA4 / GPIO_2	Cx Sensor Line / I/O
30	CxA5 / GPIO_3	Cx Sensor Line / I/O
31	CxA6 / GPIO_6	Cx Sensor Line / I/O
32	CxA7 / GPIO_7	Cx Sensor Line / I/O

In Table 2.2 a description of all communication pins are given.

Table 2.2 **Communication pins**

SPI		I ² C	
Name	Description	Name	Description
MOSI	Master Out Slave In	I2CA0	Sub-Address 0
SOMI	Slave Out Master In	SDA	Data
/SS	Slave Select	IRDY	I ² C Ready
SCK	Serial Clock	SCL	Clock
RDY	SPI Ready	Not used	

Pins are used as defined in the standard communications protocols, except for the additional RDY pin in SPI mode and the IRDY pin in I²C mode. The ready is an indication to the master that data transfer is ready to be initiated (that the communication window is available).

2.2 ICTRL

A reference resistor of 39k MUST be placed from the ICTRL I/O to ground, as shown in Figure 1.1. It is very important that the track to the resistor must be as short as possible, with the other side having a good connection to ground.

3 ProxSense® Module

The device contains a ProxSense® module that uses patented technology to provide detection of PROX/TOUCH on the numerous sensing lines. The ProxSense™ module is a combination of hardware and software, based on the principles of charge transfer. A set of measurements are taken and used for calculating the touch controller outputs.

3.1 Charge Transfer Concepts

Capacitance measurements are taken with a charge transfer process that is periodically initiated. The measuring process is referred to as a charge transfer cycle and consists of the following:



- Discharging of an internal sampling capacitor (Cs) and the sense electrode (Cx) on a channel.
- Charging of Cx's connected to the channel and then a series of charge transfers from the Cx's to the associated internal sampling capacitor (Cs), until the trip voltage is reached.

The number of charge transfers required to reach the trip voltage on a channel is referred to as the count value.

The device continuously repeats charge transfers on the sense electrode connected to the Cx Pin.

For each channel a Long Term Average (LTA) is calculated (12 bit unsigned integer values). The count value (12 bit unsigned integer values) are processed and compared to the LTA to detect TOUCH and PROX.

For more information regarding capacitive sensing, refer to the application note "AZD004 Azoteq Capacitive Sensing".

3.2 Charging Modes

The IQS316 has 16 sensor lines (Cx). The device has four internal sampling capacitors, with the touch channels charging in 4 timeslots, equating to the 16 channels. Each active sensor line is connected to a channel to determine touch button actuations. For PROX channels, a selection of the 16 touch sensor lines are combined to provide up to 4 dedicated PROX channels. For example, CxB0, CxB1, CxB2 and CxB3 are connected together, and charge as one PROX channel, namely CH1.

In the IQS316, charge transfers are implemented in two charging 'Modes', namely *Prox Mode*, and *Touch Mode*.

3.2.1 Prox Mode Charging

In *Prox Mode*, CH0 to CH3 are repeatedly charged. Collectively, they are referred to as the Group 0 charge transfers.

These channels are optimised for PROX sensing by having specific digital signal

processing performed to improve stability and sensitivity, for optimum PROX operation. The sensor lines connected to these channels are also selectable. By default, only CH0 and CH1 are active in *Prox Mode* Charging, with CxA0 – CxA3 connected to CH0 and CxB0 – CxB3 connected to CH1. This means that CxA0, CxA1, CxA2 and CxA3 form a combined sense plate for CH0.

It is possible to connect between 2 and 16 of the Cx sensor lines to the PROX channels.

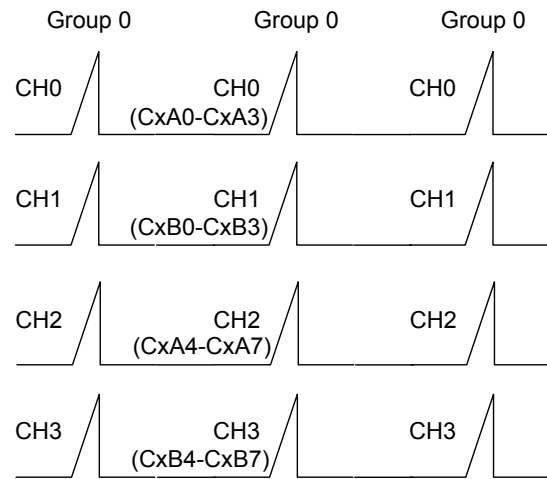

Figure 3.1 Prox Mode Charging

3.2.2 Touch Mode Charging

In *Touch Mode*, all active touch channels are sampled. If all 16 channels are enabled (default), charge transfers occur in 4 groups, namely Group1, 2, 3 and 4. In *Touch Mode*, this cycle is continually repeated. Figure 3.2 shows how the channels are connected to the respective sensor lines. The **channel number** is written, and below in brackets the respective **sensor line** is shown. For example: CH12 is the touch button output of sensor line CxA2.

The touch channels are optimised for touch response time, and less signal processing is performed compared to the *Prox Mode* channels.



power, charging takes place less often, and naturally this decreases the response time for a proximity event, this does however allow the device to sleep for long periods between conversions, decrease the power consumption considerably.

3.3 Prox Module Setup

3.3.1 Report rate

The report rate of the device depends on the charge transfer frequency and the LTA of the channels. The length of communications performed by the master device will also have an effect on the report rate of the IQS316. A typical value is shown in the characteristic data in Table 7.4.

3.3.2 Transfer Frequency

The frequency of the transfers can be selected by the main oscillator (Main_OSC) and main oscillator divider (CxDIV) settings. Conversion frequencies are given in Table 3.1 with the Main_Osc fixed at 8MHz. An optimal transfer frequency must be selected for a specific application by choosing the optimal CxDIV setting.

Table 3.1 **Charge transfer frequency**

CxDIV	Conversion Frequency
000	4MHz
001	2MHz
010	1MHz (default)
011	0.5MHz
100	0.25MHz
101-111	0.125MHz

3.3.3 Count Value

As a rough guideline, the *Prox Mode* channels (CH0 – CH3) are usually set to higher count values (800 – 1500), to optimise PROX

sensitivity. The *Touch Mode* channels (CH4 – CH19) are usually considerably lower (200 – 500), because the same sensitivity as required for PROX is not usually required for touch.

3.3.4 Prox Mode Channel Filters

The *Prox Mode* channel filter provides a major improvement on the proximity performance of the device. The filter is implemented on CH0 – CH3, and is default ON at start-up. It is recommended to keep this filter enabled.

To improve the filters effectiveness with rejecting AC mains noise, the charge transfers are synchronised to a base frequency (roughly 9ms, to accommodate both 50Hz and 60Hz). Numerous factors (charge transfer frequency, high counts, long communication time, more than two active *Prox Mode* channels etc) could cause this timing to be extended, which would simply reduce the effectiveness of the filter. Refer to Table 7.4.

3.3.5 Environmental Drift

The Long Term Average (LTA) can be seen as the baseline or reference value. The LTA is calculated to continuously adapt to any environmental drift.

3.3.6 LTA Filter

The LTA filter is calculated from the count value of each channel. The LTA filter allows the device to adapt to environmental (slow moving) drift. Touch and PROX information is calculated by comparing the count value with this LTA reference value.

For an illustration of the working of the LTA filter (and filter halt), refer to application note “AZD024 Graphical Representation of the IIR Filter”.

3.3.7 Filter Halt

To ensure that the LTA filters do not adapt during a PROX or TOUCH, a filter halt scheme is implemented on the device. The designer can choose between four options as given in Table 3.2.



Table 3.2 **Filter halt options**

T _{HALT}	Filter
Short	During PROX or TOUCH, filter halts for ~20s, then reseeds
Long (default)	During PROX or TOUCH, Filter halts for ~40s, then reseeds
Never	Filter NEVER halts
Always	Filter is HALTED, always

With the Short and Long option, the filter operates as follows:

The LTA filter will freeze on a touch or proximity for T_{HALT} seconds. After T_{HALT}, if prox/touch condition still exists, the system will assume a stuck condition, and the LTA will reseed to the count value. In applications where long user interaction is expected, the ‘Long Halt’ option is recommended.

The T_{HALT} timer is reset every time a touch is made or released.

For the ‘Never Halt’ setting, the filter will immediately begin to adapt, without ever freezing the filter. This setting is not recommended.

The ‘Always Halt’ setting can be used to enable a master device to implement a custom filter halt scheme. The master device can monitor the LTA and count values to determine when a stuck condition has occurred. This setting is useful since the master device can decide when the touch key is in a ‘stuck’ condition, and a ‘Reseed’ command could be initiated from the master to rectify this.

On the IQS316, all channels can be individually reseeded if need be, otherwise a global reseed is available.

3.3.8 Touch Sensitivity (Touch Mode channels only)

The touch sensitivity of each individual channel is a user defined threshold, calculated as a *ratio* of the count value to the LTA. Note that a user touching the sensor will cause the

count value to drop. A touch threshold of 1/32 will be the most sensitive setting and 10/16 will result in the least sensitive.

Table 3.3 **Touch Thresholds**

Setting	LOW Range	HIGH Range
00	1/32 (default)	4/16
01	1/16	6/16
10	2/16	8/16
11	3/16	10/16

Four values exist for each channel. Two ranges of settings can be selected, but the range is a global setting and applies to all channels; whereby each channel can then individually be setup to a value within the selected range.

3.3.9 Proximity Sensitivity (Prox and Touch Mode channels)

The proximity sensitivity of each individual channel is a user defined threshold calculated as a *delta* value below the LTA. A PROX status is detected when the count value drops below the selected delta relative to the LTA.

Table 3.4 **Prox Thresholds**

Setting	LOW Range	HIGH Range
00	2	8 (default)
01	3	16
10	4	20
11	6	30

Again four values exist for each channel, and again a global secondary range can be selected, changing the 4 available settings for all channels to a new set of 4 possibilities.

3.3.10 Antenna Tuning Implementation

The ATI is a sophisticated technology implemented in the new ProxSense® series devices. It allows optimal performance of the devices for a wide range of sensing electrode capacitances, without modification or addition of external components. The ATI allows the tuning of two parameters, an ATI Multiplier



and an ATI Compensation, to adjust the count value for an attached sensing electrode.

ATI allows the designer to optimise a specific design by adjusting the sensitivity and stability of each channel through the adjustment of the ATI parameters. Please refer to Azoteq Application Note AZD027 for more information regarding ATI.

The IQS316 has an automated ATI function. This allows the designer to specify a count target value for either the *Prox-* or *Touch Mode* channels, and then when activated, the system will increment the relevant ATI Compensation settings until the channels reach the target value.

Note that the ATI algorithm (and the *ATI Busy* indication) bit will only take effect once the communication window where the AutoATI is requested has been ended.

4 Additional Features

4.1 RF Immunity

The IQS316 has immunity to high power RF noise. In this section general design guidelines will be given to improve noise immunity and the noise detection functionality is explained.

4.1.1 Design Guidelines

To improve the RF immunity, extra decoupling capacitors are suggested on V_{REG} and V_{DDHI} .

Place a 100pF in parallel with the 1uF ceramic on V_{REG} and V_{DDHI} . All decoupling capacitors should be placed as close as possible to the V_{DDHI} and V_{REG} device pins.

PCB ground planes also improve noise immunity. Care must be taken to not pour these planes near the tracks/pins of the sensing lines, see Figure 4.1. Ground/voltage planes close to the sensing channels have a negative effect on the sensitivity of the sensors. Note, if I/O's are used instead of the sensor lines, the ground pour can also go under these pins.

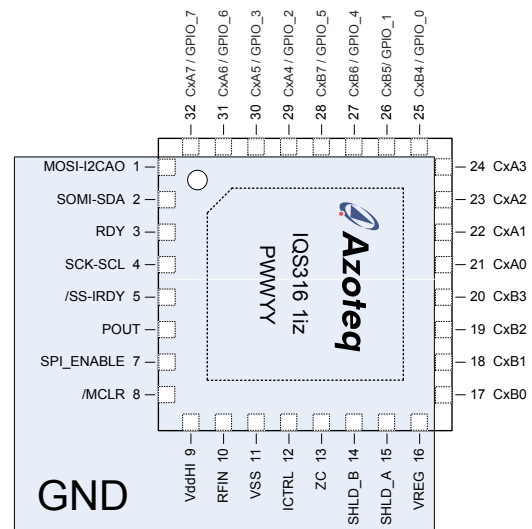

Figure 4.1 Ground plane routing

4.1.2 RF detection

In cases of extreme RF interference, the on-chip RF detection is suggested. By connecting a suitable antenna to the RF pin, it allows the device to detect RF noise and notify the master of possible corrupt data. A 50Ω pull-down resistor should be placed on RFIN. Note that the value of the resistor should match the impedance of the antenna.

Noise affected samples are not allowed to influence the LTA filter, and also do not contribute to PROX or TOUCH detection.

If this function is not implemented in design, it is recommended to disable the noise detection in the firmware.

4.2 Active Shield

The IQS316 has two active driven shield outputs, shielding the sensor lines from false touches and proximities, and countering the effect of parasitic ground sources. Using internal driven shields in applications where the environment requires shielding lowers the cost of the final solution by avoiding the necessity of external shield components.

Manual control of the shield is provided by the IQS316 (allowing CxA0/CxB0 to CxA6/CxB6 to be shielded). Additionally, an automatic shield implementation can be selected, allowing automatic setup of the shield each cycle. The channels that are set by the



automatic selection are highlighted in the table.

Table 4.1 **Automatic Shield Setting Channels**

Group	SHLD_A	SHLD_B
0	CxA0	CxB0
1	CxA0	CxB0
2	CxA1	CxB1
3	CxA2	CxB2
4	CxA3	CxB3

The active driven shields follow the waveforms of the sensor lines. A screenshot of two pairs of shield and sensor lines are illustrated in Figure 4.2. It can be seen that generally 2 different channels have very similar signals, and it has been found that the shield of a specific channel can be effectively used to shield the other channels in the same timeslot (Group).

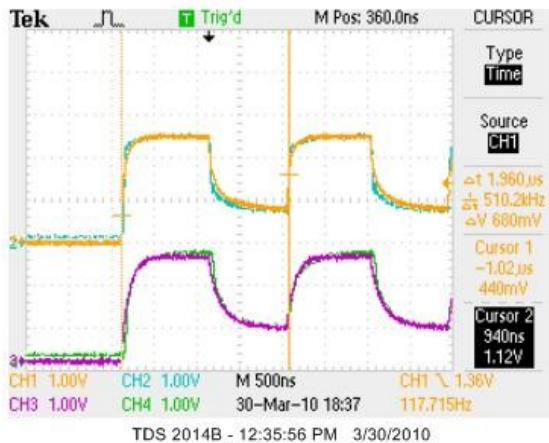

Figure 4.2 **Active shields**

Pull-up resistors are required on each shield line as shown in Figure 6.9 and Figure 6.10. A suggested value for the pull-up resistors are 2kΩ when using the controller at 3.3V, and 4.7kΩ when using the controller at 5V. Smaller resistor values will increase the driving ability of the shield, but will also increase the current consumption.

For more information regarding shielding, refer to the application note “AZD009 Implementation of Driven Shield”.

4.3 Proximity Output (POUT)

All the individual PROX status for each channel is available through the device memory map, but an additional POUT I/O has been added. This I/O is active HIGH when any of the PROX channels (CH0 – CH3) sense a PROX. This could, for example, be used to control the backlighting of an application.

4.4 Zero Cross Synchronising

When an application is operated in a noisy AC environment, it could be required to synchronise the charging to the AC. This reduces the noise influence on the count value. This is not normally required since the *Prox Mode* filters should remove this AC component, but is available if needed.

If unused, it is best to connect directly to GND.

4.5 Device Sleep

The IQS316 can be placed in low power SLEEP mode. This however is a totally inactive state, and no channel sensing is performed. This could be used if an application does not require the keys to be sensed, or if custom low power mode is implemented. All the device settings and data is retained after waking from the sleep.

4.6 Communication Bypass

The IQS316 can be set up to bypass the communication window. This could be useful if a master does not want to be interrupted during every charging cycle of the IQS316. The communication will be resumed (Ready will indicate available data) if the IQS316 senses a proximity. The master can also initiate communication if required (only in SPI). Therefore the master sends a command to bypass the communication. The IQS316 then continually does conversions without interaction with the master, until a proximity occurs, which is most likely the first time that the master will be interested in the IQS316 data.

If the master wants to force the communication to resume in SPI mode, then



the /SS must be pulled LOW to select the device. Then the master must still wait for the RDY to go HIGH, then communication is resumed.

After communication is resumed, both by the master or the slave, then the bypass is removed. Thus if required again, it must be reconfigured.

4.7 General Purpose I/O's

The IQS316 has 8 GPIO's available. It is possible to use 0, 4 or 8 I/O's, leaving 16, 12 or 8 Cx channels respectively. These I/O's can be controlled via the memory map. The following considerations should be given when using these I/O's:

- They provide only a logic level indication (no current sourcing capabilities), thus for example, if LED's are to be switched, the I/O must connect to the gate of a FET (thus only capacitive loads).
- Updating the TRIS of the I/O's is only done after the termination of the communication window.
- The state of a GPIO can only be read/written during a communication window, since it is controlled via the memory map.
- The I/O's switch to Vreg voltage.

5 Application Design

5.1 Physical Layout

For more information regarding the layout of the buttons / electrode, please refer to the application note "AZD008 Design Guidelines for Touch Pads." Information such as button size and shape, overlay type and thickness, sensor line routing, and ground effects on sensing are highlighted.

5.2 Cx Selection

A few points need to be considered when designing a multi-key application. Factors such as noise, shielding and proximity requirements need to be evaluated. A few key

decisions are highlighted here, referring to Figure 5.1 to illustrate the options. This is mostly important when less than 16 keys are required, and the Cx's that are to be used in the design are chosen.

	Group 0	Group 1	Group 2	Group 3	Group 4
Row 0	CH0 (CxA0-CxA3)	CH4 (CxA0)	CH8 (CxA1)	CH12 (CxA2)	CH16 (CxA3)
Row 1	CH1 (CxB0-CxB3)	CH5 (CxB0)	CH9 (CxB1)	CH13 (CxB2)	CH17 (CxB3)
Row 2	CH2 (CxA4-CxA7)	CH6 (CxA4)	CH10 (CxA5)	CH14 (CxA6)	CH18 (CxA7)
Row 3	CH3 (CxB4-CxB7)	CH7 (CxB4)	CH11 (CxB5)	CH15 (CxB6)	CH19 (CxB7)

Figure 5.1 Cx Channel Selection

5.2.1 Cx Sensor Close to Noise Source

If the design is such that some channels will be in close proximity to a noisy environment, it is always good to group these channels together in the same **row**, where rows are illustrated in Figure 5.1. This is so that if channels are affected by noise, they will influence less of the *Prox Mode* channels (noise could reduce the effectiveness of proximity sensing). These *Prox Mode* channel(s) can then be set up with an insensitive PROX threshold, or can be disabled.

5.2.2 Cx Sensors Requiring Shield

If the design requires the use of shields, it can be useful to select the Cx's according to those used by the automatic shield function (Section 4.2). The Cx's used by this are circled in Figure 5.1.

5.2.3 Cx Sensors Used For Prox

If specific channels are required to provide good proximity sensing, then it is recommended to also keep these in the same row, preferably row0 and row1 as circled (since these are part of CH0 and CH1 which are default active). If you require independent proximity information, then these channels must be chosen to be in different rows (since all channels in the same row charge together to give a collective PROX result).



5.2.4 Cx Sensors plus I/O's

If the I/O's are to be used, the Cx's must be selected appropriately. If 8 I/O's are used, then the 8 Cx's available are again those circled in the figure, the remaining are then converted to I/O's. If 12 Cx's are required with 4 I/O's, then the I/O's used will be either:

CxA4, CxA5, CxB4 and CxB5 or

CxA6, CxA7, CxB6 and CxB7.

The remaining 12 will thus be the sensor lines.

5.2.5 Unused Cx's

It is important to disable unused Cx's, since this increases the response time of the device, as shown in Table 7.4.

6 Communication

The IQS316 can communicate in SPI or I²C using the respective standard communication protocols. Both communication protocols are implemented with similar interaction with the memory map. For both of the communication protocols, the respective Ready I/O will be set when data is available.

A general I²C and SPI Memory Map is defined so that all ProxSense[®] devices can use a standard framework. The complete Memory Map is defined in the "AZD032 IQS316 Communication Interface" document. This document is a design guideline covering all the specific device details, device information, and settings.

In I²C and SPI mode a WRITE = 00 and a READ = 01.

6.1 Communication Selection

The IQS316 uses I²C communication by default. To enable SPI communication, the SPI enable pin must be pulled HIGH at start-up, which will configure the device to SPI mode. The *SPI_ENABLE* input pin can be connected to V_{DDHI} or a pull-up resistor smaller than 39kΩ can be used.

6.2 Watchdog Timeout and MCLR

When data is available, and Ready is set, the device will allow a full watchdog period (16ms

@ 8Mhz) to be serviced. If the device is not serviced within this time, a reset will occur. The watchdog is **disabled** by default and can be enabled in the Memory Map. It is advised to disable the watchdog timer during the development phase.

The watchdog is also not crucial, since a MCLR pin is available for the master to reset the IQS316. The MCLR has an internal pull-up resistor. To reset, pull the MCLR LOW (active LOW).

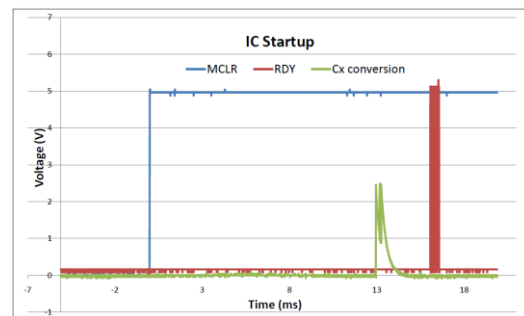

Figure 6.1 Communication start-up time

It can be seen in Figure 6.1 that it takes roughly 16ms for communication to start after the MCLR pin has been released. The IC does an initial conversion, while performing device initialisation and calculations, after which the communication window is available.

6.3 SPI

SPI uses a memory mapped structure when sending or retrieving data to/from the IC. The device must be selected by pulling the /SS low.

At the beginning of a communication window, the pointer will be set to a default value. This value can be overwritten to change the default pointer position. Note that the clock polarity is idle high, and the data is sampled at the second edge of the clock pin (rising edge).

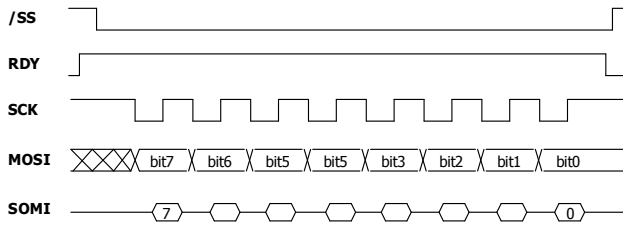

Figure 6.2 SPI timing illustration

6.3.1 SPI read

The SPI read is performed by sending the 'Read' bit in the control byte during the first data time-slot. The pointer will increment and step through the relevant memory mapped blocks, as long as the value sent in to the device is 'FE'. If an 'FF' is sent, the SPI read cycle is terminated. If any value other than a 'FE' or an 'FF' is received, that value will be loaded into the address pointer, and the next

data read from the IC will be from that specific address, as long as that address is a valid Read Address from the memory map. This speeds up the reading of sporadic addresses, by allowing addresses to be specified 'on the fly'. When an illegal address is specified in a read operation, the device will return a '27' decimal, the IQS316 product number.

An example of the read process is illustrated in Figure 6.3.

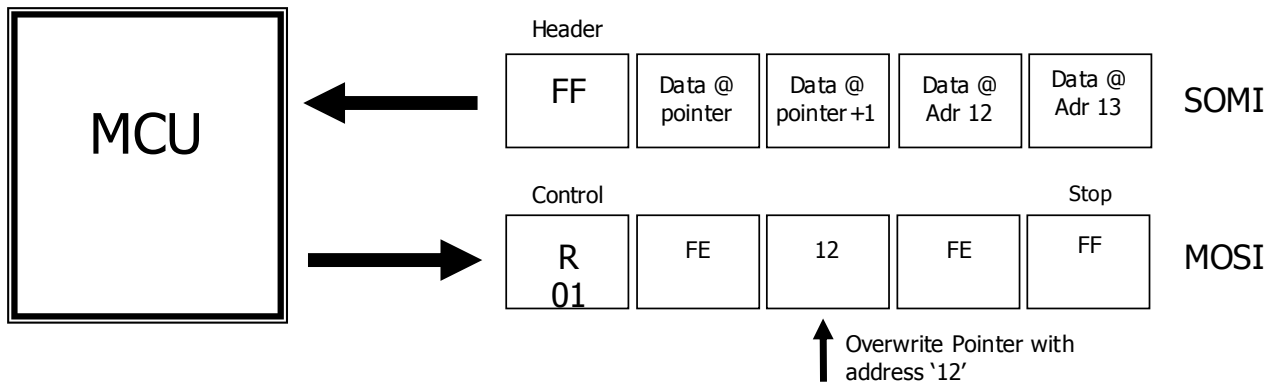

Figure 6.3 SPI Read

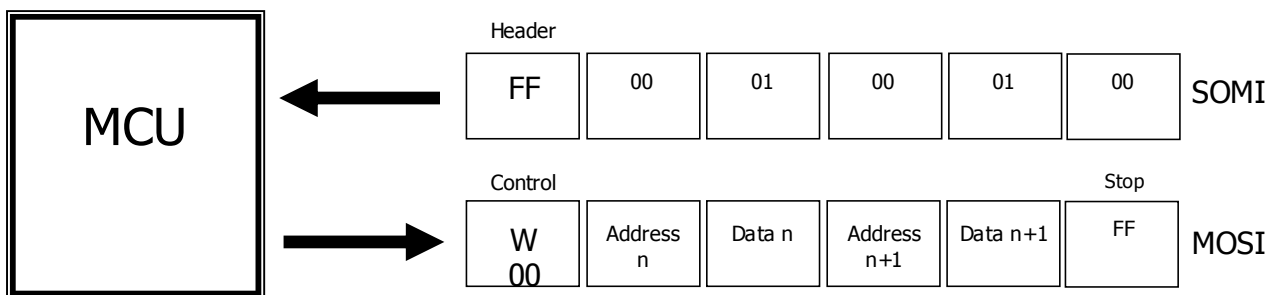

Figure 6.4 SPI Write

6.3.2 SPI write

Similar to the read, while receiving the 'header' byte, a WRITE must be selected in the control byte. The address to which to write to always precedes the data (address, data, address, data...)

An example of the SPI write process is given in Figure 6.4. If an 'FF' is sent as an address, the Write cycle is terminated. The value 'FF' is sent in the Read and Write cycle to terminate the respective cycles, but will not terminate the communication window.



6.3.3 SPI Communications Window 6.4.2 I²C read Terminate Command

Once the master received all required data from the device, and has written any required settings to the device, the communication must be ended, so that the IC can perform another charge transfer. To achieve this, a value of 'FE' must be written in the Address time slot of a WRITE cycle.

6.4 I²C

The IQS316 can communicate on an I²C compatible bus structure. Note that 4.7kΩ pull-up resistors should be placed on SDA and SCL.

6.4.1 Control byte and Device Address

The Control byte indicates the 7-bit device address and the Read/Write indicator bit. The structure of the control byte is shown in Figure 6.5.

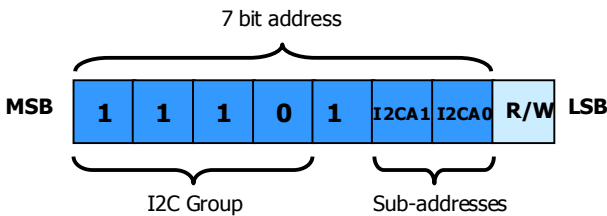

Figure 6.5 I²C control byte

The I²C device has a 7 bit Slave Address in the control byte as shown in Figure 6.5. To confirm the address, the software compares the received address with the device address. Sub-address 0 of the device address is a static variable read from state of the I2CA0 pin at start-up. The default value of Sub-address 1 (I2CA1) is '0', please contact your local Azoteq distributor for devices with I2CA1 set to '1'.

The two sub-addresses allow 4 IQS316 slave devices to be used on the same I²C bus, as well as to prevent address conflict.

The fixed device address is '11101' followed by the 2 sub-address bits, giving a default 7-bit address of '1110100'.

With the R/W bit SET in the control byte, a read is initiated. Data will be read from the address specified by the internal address pointer (Figure 6.6). This pointer will be automatically incremented to read through the memory map data blocks. If a random address is to be read, a *Random Read* must be performed. The process for a Random Read is as follows: write to the pointer (*Word Address* in Figure 6.7), initiate a repeated-Start, read from the address.

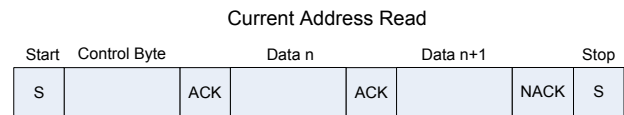

Figure 6.6 I²C Current Address Read



Figure 6.7 I²C Random Read

6.4.3 I²C write

With the R/W bit cleared in the control byte, a write is initiated. An I²C write is performed by sending the address, followed by the data. Unlike the SPI write, the Address is only sent once, followed by data bytes. A block of data can be written by sending the address followed by multiple blocks of data. The internal address pointer is incremented automatically for each consecutive write, if the pointer increments to an address which doesn't exist in the memory map, no write will take place.

Note that the pointer doesn't automatically jump from the end of the LT average block to the settings block.

An example of the write process is given in Figure 6.8.

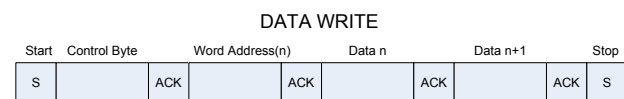

Figure 6.8 I²C write



6.4.4 I²C Communications Window Terminate Command

To terminate the communication window in I²C, a STOP is given. When sending numerous Read and Write commands in one communication cycle, a 'Repeated Start' command must be used to stack them together (since a STOP will jump out of the communication window, which is not desired).

Circuit diagrams of implementations using additional features are shown in Figure 6.9 and Figure 6.10. Additional 100pF decoupling capacitors are placed on VDDHI and VREG to increase the noise immunity of the controller. In Figure 6.9 the controller is configured to communicate in SPI mode and in Figure 6.10 the controller is configured to communicate in I2C mode.

6.5 Circuit diagrams (all features)

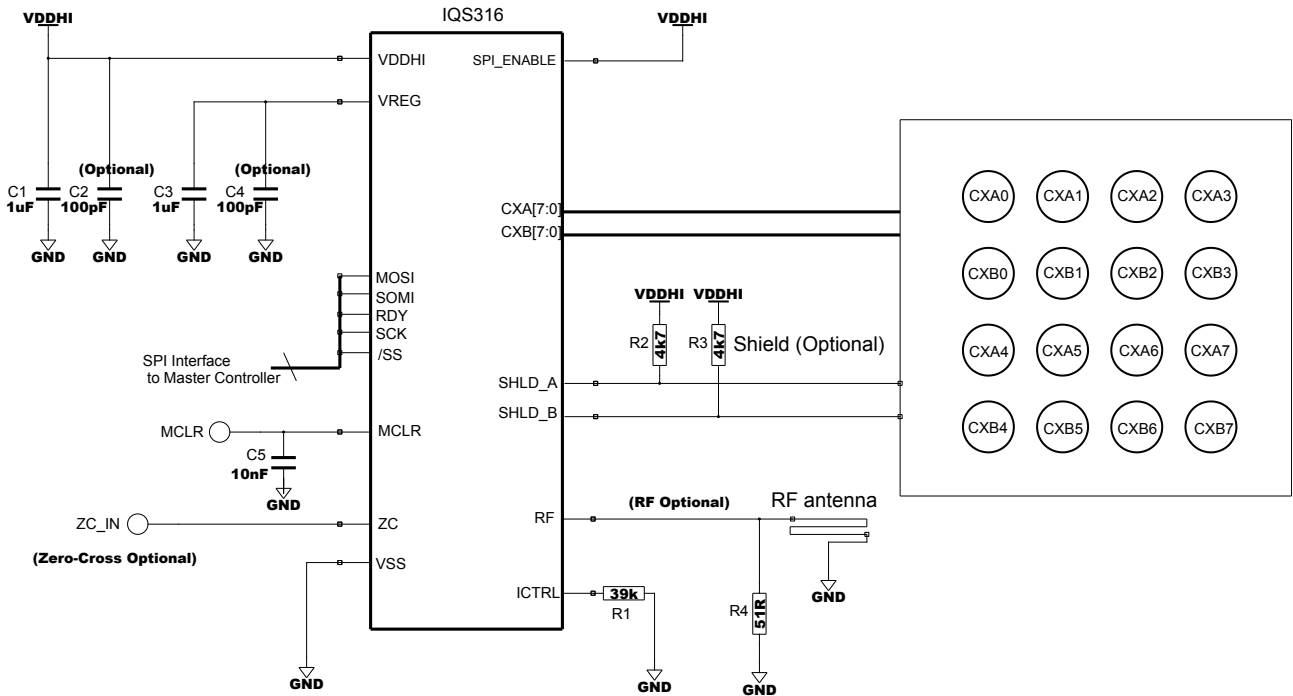

Figure 6.9 Circuit diagram for SPI implementation

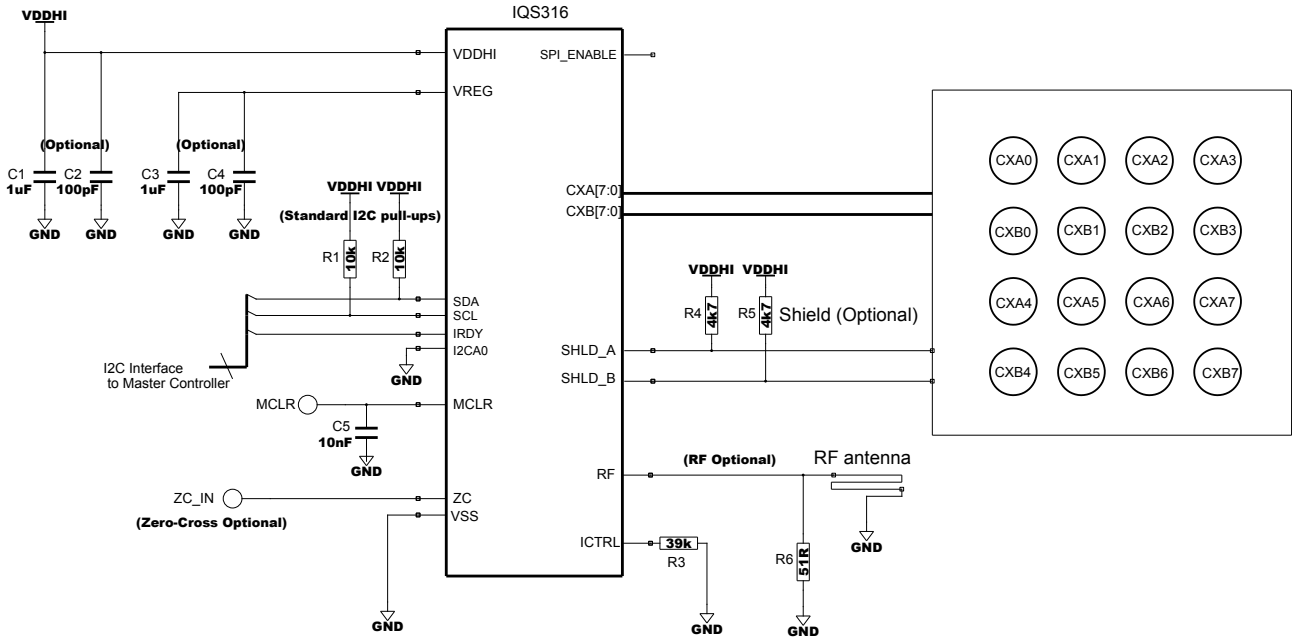

Figure 6.10 Circuit diagram for I²C implementation

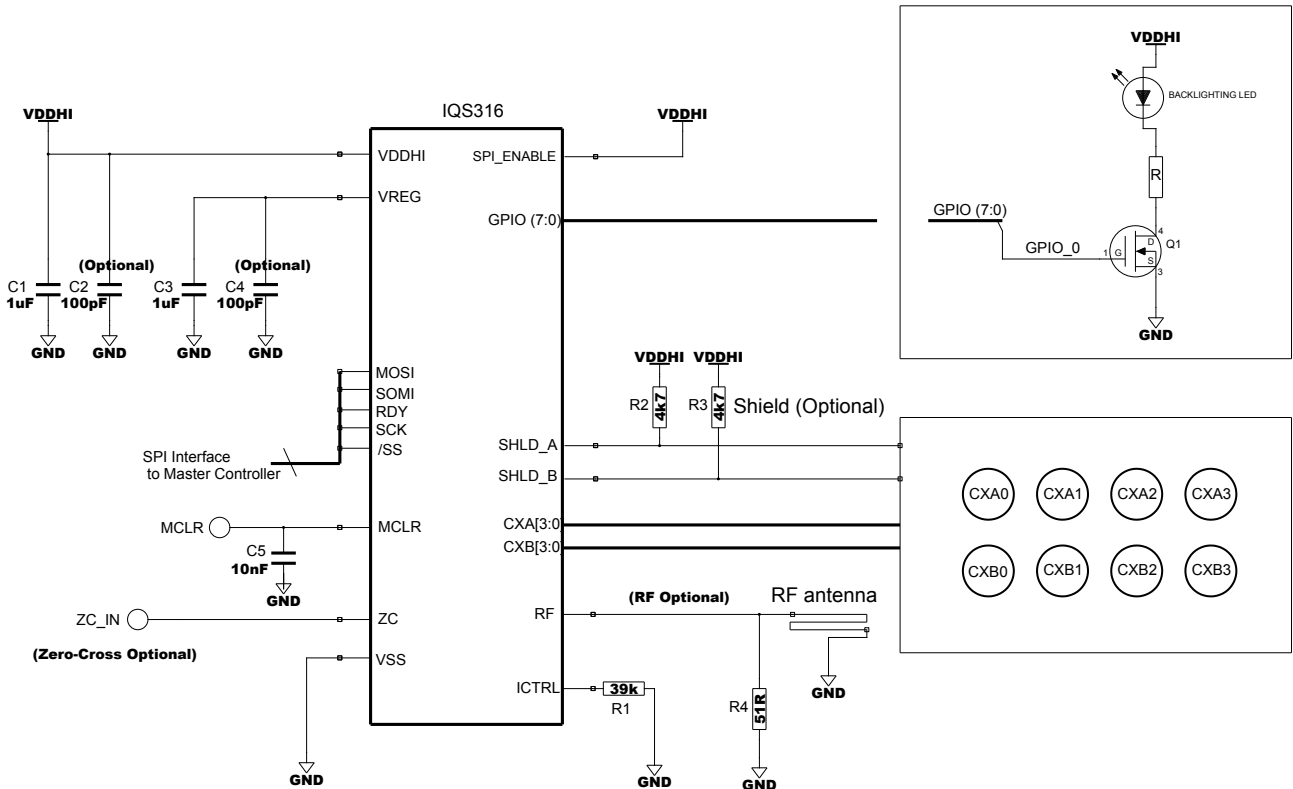

Figure 6.11 Circuit Diagram for 8 GPIO implementation



7 Electrical specifications

7.1 Absolute maximum specifications

Operating temperature	-40°C to 85°C
Supply Voltage ($V_{DDHI}-V_{SS}$)	5.5V
Max pin voltage for ESD= V_{DDHI}	$V_{DDHI} + 0.5V$
Maximum pin voltage for ESD= V_{REG}	$V_{REG} + 0.5V$
Min pin voltage	$V_{SS} - 0.5V$
Min power on slope	100V/s
ESD protection (Human Body Model)	3kV
Latch-up current	100mA

7.2 Operating conditions (Measured at 25°C)

Table 7.1 Electrical operating conditions

Description	Conditions	Parameter	Min	Typ	Max	Unit
Internal regulator output	$2.85V < V_{DDHI} < 5.5V$	V_{REG}	2.3	2.4	2.5	V
Supply voltage		V_{DDHI}	2.85		5.5	V
Normal operating current	$2.85V < V_{DDHI} < 5.5V$	I_{NP}		640		μA
Normal operating current	$V_{DDHI} = 3.3V + 4\text{shields}$	I_{NP}		4		mA
Low power operating current (LP1)	$2.85V < V_{DDHI} < 5.5V$	I_{LP1}		100		μA
Low power operating current (LP2)	$2.85V < V_{DDHI} < 5.5V$	I_{LP2}		60		μA
Low power operating current (LP3)	$2.85V < V_{DDHI} < 5.5V$	I_{LP3}		45		μA
Current in SLEEP mode	$2.85V < V_{DDHI} < 5.5V$	I_{SL}		20		μA
Main Oscillator (8MHz setting)	$2.85V < V_{DDHI} < 5.5V$	Fosc	7.36	8	8.64	MHz

7.3 Moisture Sensitivity Level

Moisture Sensitivity Level (MSL) relates to the packaging and handling precautions for some semiconductors. The MSL is an electronic standard for the time period in which a moisture sensitive device is allowed to be exposed to ambient room conditions (approximately 30°C/60%RH) before reflow must occur.

Table 7.2 MSL

Package	Level (duration)
QFN5x5-32	MSL 3 (168 hours)



7.4 Timing characteristics (Measured at 25°C)

Table 7.3 Timing characteristics

Description	Symbol	Min	Typical	Max	Unit
SPI clock frequency	F_{SCK}		0.4	0.8	MHz
I ² C clock frequency	F_{SCL}		0.1		MHz
Charge transfer oscillator (setting = osc/8)	F_{CX}	0.92	1	1.08	MHz
Filter Halt Short	t_{FHS}		20		s
Filter Halt Long	t_{FHL}		40		s
Mode timer	T_{MODE}		4		s

Table 7.4 IQS316 Data Report Rate²

Charging Mode	Total Groups Charging	Number of Channels per Group	Total Channels	Typical	Unit
Prox Mode	1	4	4	110 ^{Note1}	Hz
Prox Mode	1	3	3	110 ^{Note1}	Hz
Prox Mode	1	2	2	110 ^{Note1}	Hz
Prox Mode	1	1	1	110 ^{Note1}	Hz
Touch Mode	4	4	16	41	Hz
Touch Mode	3	4	12	54	Hz
Touch Mode	2	4	8	82	Hz
Touch Mode	1	4	4	161	Hz
Touch Mode	1	3	3	192	Hz
Touch Mode	1	2	2	238	Hz
Touch Mode	1	1	1	250	Hz

Note 1: In *Prox Mode*, the target charging frequency can decrease if certain situations exist. For example if lengthy communication is done, the frequency will decrease, or if the charge transfer is long (slower prox oscillator divider, or very high count values).

Note 2: Measurements in Table 7.4 were obtained with the following settings:

- *Prox Mode* count values = ±1000
- *Touch Mode* count values = ±500
- 4 bytes read per cycle (XY info, Prox, Touch and Group).

8 Mechanical Dimensions

8.1 IQS316 Mechanical Dimensions

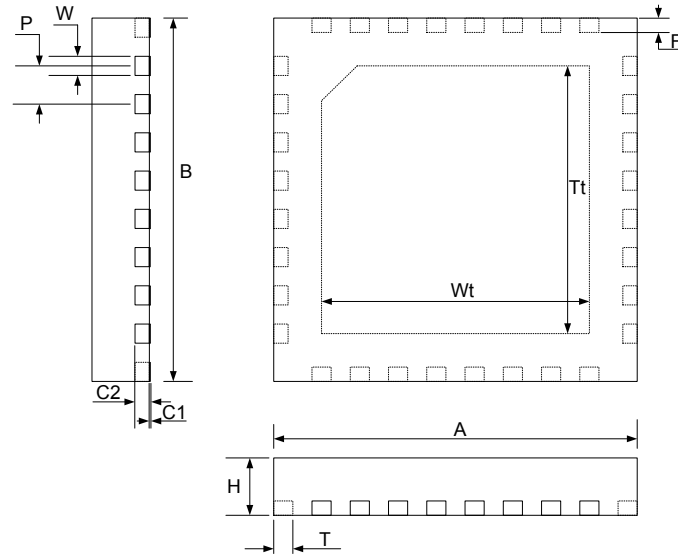

Figure 8.1 IQS316 Package. Drawings not too scale - illustration only.

Table 8.1 Packaging Dimensions.

DESCRIPTION	QNR		QFR		Unit
	MIN	MAX			
A	4.90	5.10	4.90	5.10	mm
B	4.90	5.10	4.90	5.10	mm
C1	0	0.05	0	0.05	mm
C2	0.203TYP		0.203TYP		mm
F	0.600TYP		0.3	0.4	mm
H	0.85	0.95	0.85	0.95	mm
P	0.5TYP		0.5TYP		mm
T	0.3	0.5	0.3	0.5	mm
T_t	3.3 TYP		3.55	3.75	mm
W	0.25TYP		0.25TYP		mm
W_t	3.3 TYP		3.55	3.75	mm



8.1.2 QFR package differences to QNR package

The overall physical size of the part ($l \times w \times h$) and pitch of the pins did not change.

The mechanical dimensions of the saddle (T_t & W_t) and length of the pins (F) have changed from the old part (IQS316-0-QNR) to the new part (IQS316-0-QFR). The new dimensions are given below:

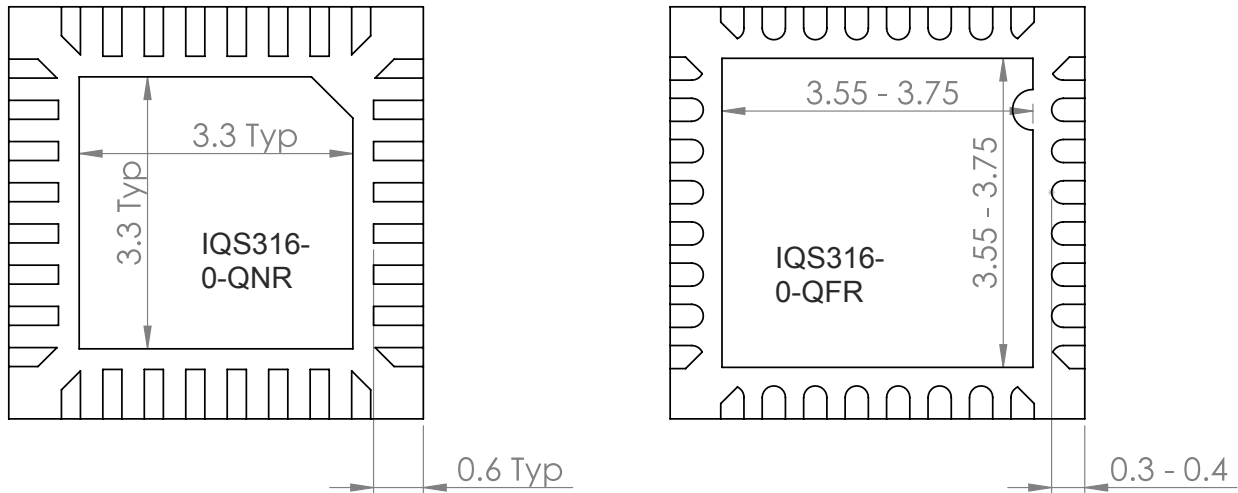

Figure 8.2 Changes in Package. Only affected dimensions are shown. Drawing for illustration only, not too scale.



8.2 IQS316 Landing Pad Layout

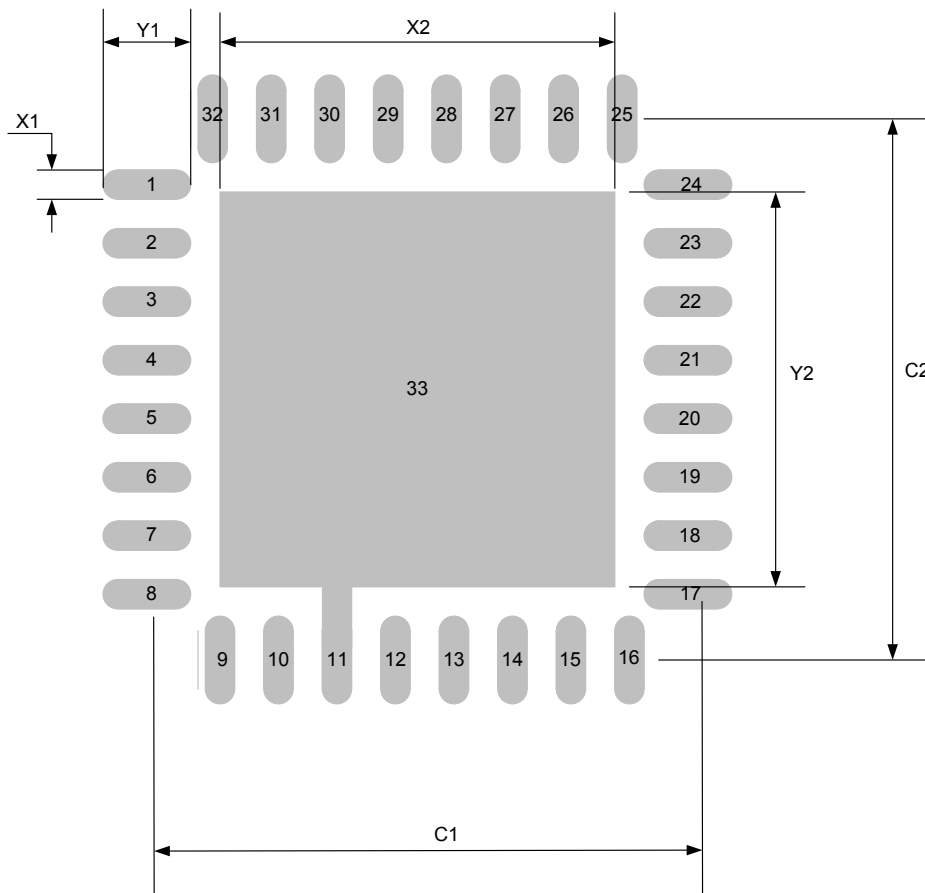

Figure 8.3 IQS316 Footprint. Illustration not to scale.

*NOTE: Pad 33 must be connected to GND.

Table 8.2 Dimensions from Figure 8.3

DESCRIPTION	QFN	QFR	Unit
	Dimension	Dimension	
C1	4.90	4.85	mm
C2	4.90	4.85	mm
X1	0.30	0.25	mm
X2	3.25	3.65	mm
Y1	0.90	0.8	mm
Y2	3.25	3.65	mm



9 Datasheet and Part-number Information

9.1 Ordering Information

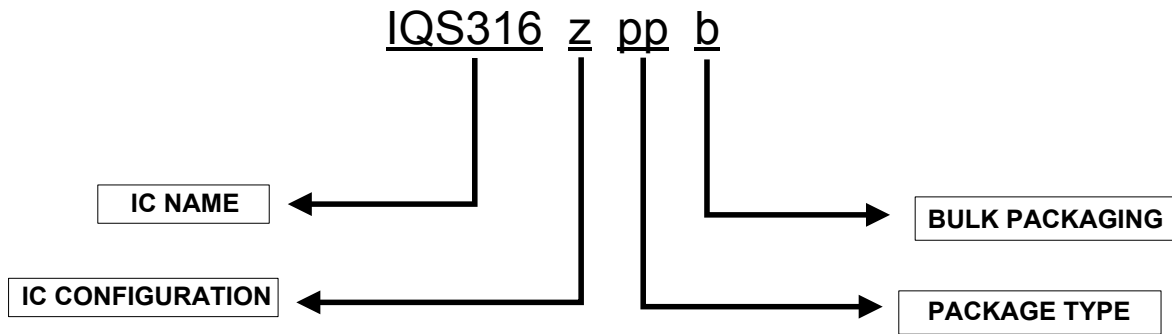

IC CONFIGURATION	z	=	0 : I ² C Sub-address 1 = 0 1 : I ² C Sub-address 1 = 1
PACKAGE TYPE	QN	=	QFN32
	QF	=	QFR32
BULK PACKAGING	QFN5x5-32	R	= Reel (3000 pcs/reel)
		MOQ	= 1 reel. Mass production orders shipped as full reels

9.2 Package Marking

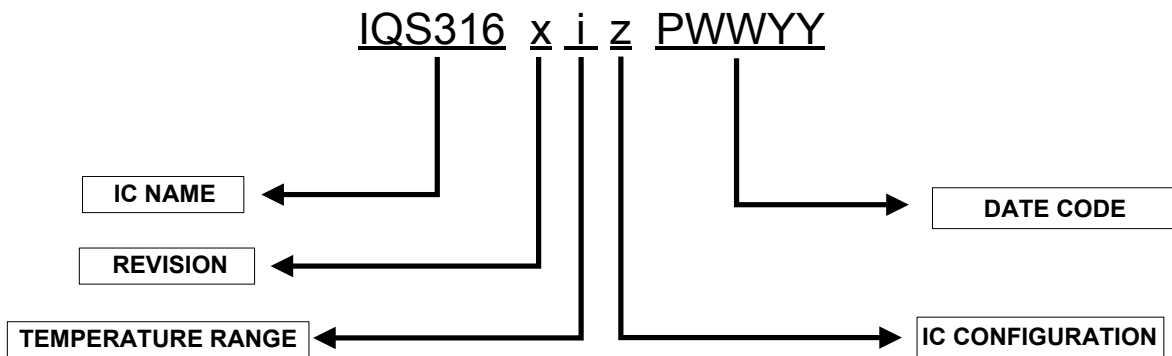

REVISION	X	=	IC Revision Number
TEMPERATURE RANGE	i	=	-40°C to 85°C (Industrial)
IC CONFIGURATION	z	=	I ² C Sub-address 1 = 0 I ² C Sub-address 1 = 1
DATE CODE	P	=	Package House
	WW	=	Week



YY = Year

9.3 Tape and Reel

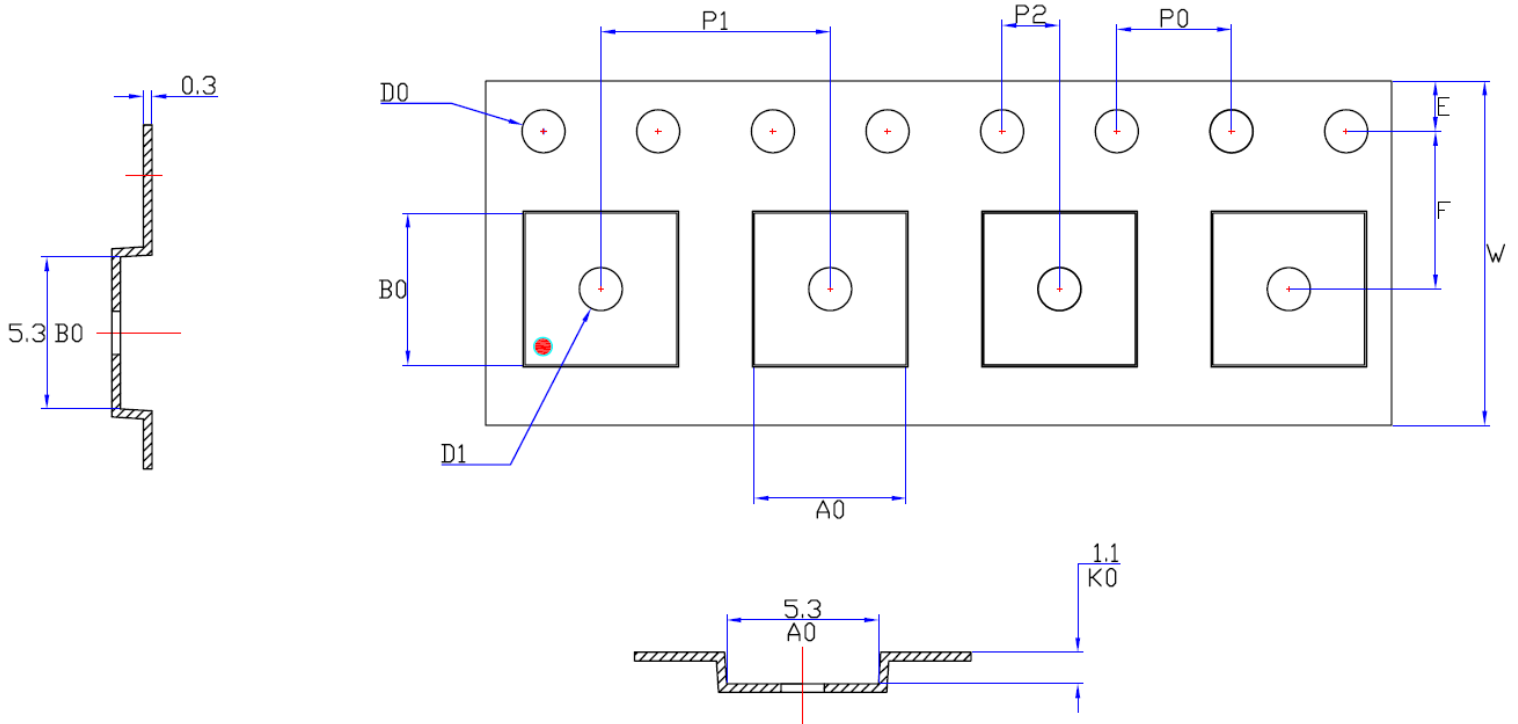

Figure 9.1 Tape Dimensions Figure

Table 9.1 Tape Dimensions Table

LABEL	Dimensions (mm)	LABEL	Dimensions (mm)
A0	5.3 ± 0.10	P0	4.0 ± 0.10
B0	5.3 ± 0.10	P1	8.0 ± 0.10
D0	1.5 ± 0.10	P2	2.0 ± 0.05
D1	1.5 ± 0.25	10xP0	40.0 ± 0.2
E	1.75 ± 0.10	T	0.3 ± 0.05
F	5.5 ± 0.05	W	12.0 ± 0.30
K0	1.1 ± 0.10		

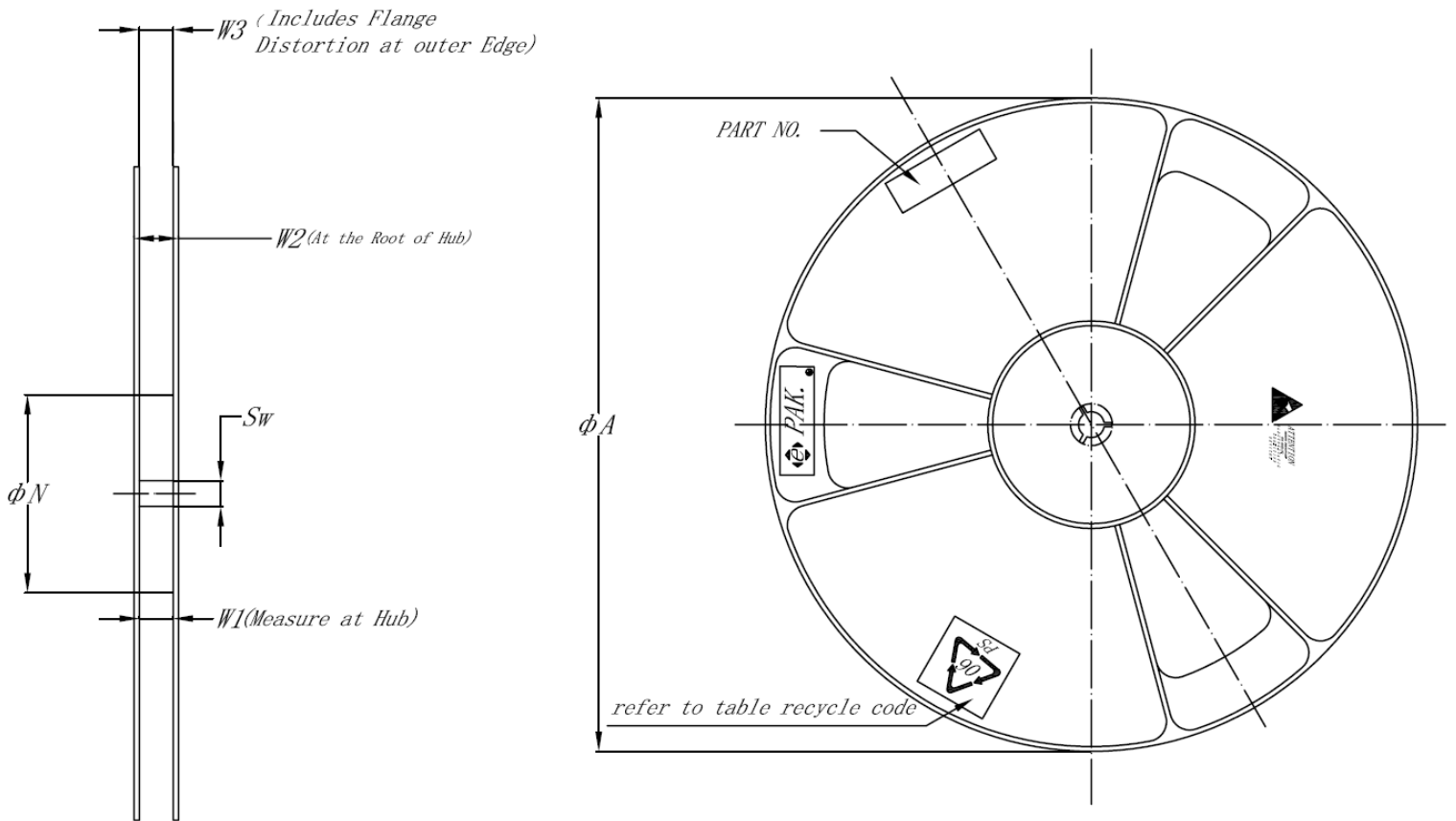

Figure 9.2 Reel Dimension Figure

Table 9.2 Reel Dimension Table

Tape Size		Combination		Part Number	
12		13/04-04-1	13/04-08-1	T12-13/04-A1	
A(+0.25/-4.0)	N(±2.0)	W1(+2/-0)	W2(Max)	W3(Min/Max)	Sw
330	100	12.4	18.4	11.9/15.4	6.0



9.5 Revision History

Revision Number	History
V0.03	<ul style="list-style-type: none">• Added Section 2.2• Updated Figure 2.1 (new qfn package)• Update Section 8.1.
V0.04	<ul style="list-style-type: none">• Fixed Section 9.1 bulk packaging description and removed tube option• Added Section 9.3 (tape and reel details)• Updated 7.1 (ESD Model)• Updated patents• Fixed text Section 3.2
V0.05	<ul style="list-style-type: none">• Terminology updated• Updated to Section 4.6• Updated to Section 2.2• Updated Section 4.4• Connected ZC to ground in Figure 1.1• Added ground tab information to Section 8.1.2• Updated Figure 2.1• Updated Section 4.1.2• Added MSL details Section 7.3
V1.00	<ul style="list-style-type: none">• Added footer first page• Updated Table 3.3 and Table 3.4 to show selection bits• Updated Section 3.3.10• Updated Table 7.3• Updated contacts section
V1.01	<ul style="list-style-type: none">• Add QFR32 package descriptions
V1.02	<ul style="list-style-type: none">• Updated contacts section



Appendix A. Contact Information

	USA	Asia	South Africa
Physical Address	6507 Jester Blvd Bldg 5, suite 510G Austin TX 78750 USA	Rm2125, Glittery City Shennan Rd Futian District Shenzhen, 518033 China	109 Main Street Paarl 7646 South Africa
Postal Address	6507 Jester Blvd Bldg 5, suite 510G Austin TX 78750 USA	Rm2125, Glittery City Shennan Rd Futian District Shenzhen, 518033 China	PO Box 3534 Paarl 7620 South Africa
Tel	+1 512 538 1995	+86 755 8303 5294 ext 808	+27 21 863 0033
Fax	+1 512 672 8442		+27 21 863 1512
Email	kobusm@azoteq.com	linayu@azoteq.com.cn	info@azoteq.com

Please visit www.azoteq.com for a list of distributors and worldwide representation.

The following patents relate to the device or usage of the device: US 6,249,089 B1; US 6,621,225 B2; US 6,650,066 B2; US 6,952,084 B2; US 6,984,900 B1; US 7,084,526 B2; US 7,084,531 B2; US 7,265,494 B2; US 7,291,940 B2; US 7,329,970 B2; US 7,336,037 B2; US 7,443,101 B2; US 7,466,040 B2 ; US 7,498,749 B2; US 7,528,508 B2; US 7,755,219 B2; US 7,772,781 B2; US 7,781,980 B2; US 7,915,765 B2; US 7,994,726 B2; US 8,035,623 B2; US RE43,606 E; US 8,288,952 B2; US 8,395,395 B2; US 8,531,120 B2; US 8,659,306 B2; US 8,823,273 B2; EP 1 120 018 B2; EP 1 206 168 B1; EP 1 308 913 B1; EP 1 530 178 A1; EP 2 351 220 B1; EP 2 559 164 B1; CN 1330853; CN 1783573; AUS 761094; HK 104 1401

IQ Switch®, SwipeSwitch™, ProxSense®, LightSense™, AirButton® and the  logo are trademarks of Azoteq.

The information in this Datasheet is believed to be accurate at the time of publication. Azoteq uses reasonable effort to maintain the information up-to-date and accurate, but does not warrant the accuracy, completeness or reliability of the information contained herein. All content and information are provided on a "as is" basis only, without any representations or warranties, express or implied, of any kind, including representations about the suitability of these products or information for any purpose. Azoteq disclaims all warranties and conditions with regard to these products and information, including but not limited to all implied warranties and conditions of merchantability, fitness for a particular purpose, title and non-infringement of any third party intellectual property rights. Azoteq assumes no liability for any damages or injury arising from any use of the information or the product or caused by, without limitation, failure of performance, error, omission, interruption, defect, delay in operation or transmission, even if Azoteq has been advised of the possibility of such damages. The applications mentioned herein are used solely for the purpose of illustration and Azoteq makes no warranty or representation that such applications will be suitable without further modification, nor recommends the use of its products for application that may present a risk to human life due to malfunction or otherwise. Azoteq products are not authorized for use as critical components in life support devices or systems. No licenses to patents are granted, implicitly, express or implied, by estoppel or otherwise, under any intellectual property rights. In the event that any of the abovementioned limitations or exclusions does not apply, it is agreed that Azoteq's total liability for all losses, damages and causes of action (in contract, tort (including without limitation, negligence) or otherwise) will not exceed the amount already paid by the customer for the products. Azoteq reserves the right to alter its products, to make corrections, deletions, modifications, enhancements, improvements and other changes to the content and information, its products, programs and services at any time or to move or discontinue any contents, products, programs or services without prior notification. For the most up-to-date information and binding Terms and Conditions please refer to www.azoteq.com.

WWW.AZOTEQ.COM

info@azoteq.com



Компания «ЭлектроПласт» предлагает заключение долгосрочных отношений при поставках импортных электронных компонентов на взаимовыгодных условиях!

Наши преимущества:

- Оперативные поставки широкого спектра электронных компонентов отечественного и импортного производства напрямую от производителей и с крупнейших мировых складов;
- Поставка более 17-ти миллионов наименований электронных компонентов;
- Поставка сложных, дефицитных, либо снятых с производства позиций;
- Оперативные сроки поставки под заказ (от 5 рабочих дней);
- Экспресс доставка в любую точку России;
- Техническая поддержка проекта, помощь в подборе аналогов, поставка прототипов;
- Система менеджмента качества сертифицирована по Международному стандарту ISO 9001;
- Лицензия ФСБ на осуществление работ с использованием сведений, составляющих государственную тайну;
- Поставка специализированных компонентов (Xilinx, Altera, Analog Devices, Intersil, Interpoint, Microsemi, Aeroflex, Peregrine, Syfer, Eurofarad, Texas Instrument, Miteq, Cobham, E2V, MA-COM, Hittite, Mini-Circuits, General Dynamics и др.);

Помимо этого, одним из направлений компании «ЭлектроПласт» является направление «Источники питания». Мы предлагаем Вам помощь Конструкторского отдела:

- Подбор оптимального решения, техническое обоснование при выборе компонента;
- Подбор аналогов;
- Консультации по применению компонента;
- Поставка образцов и прототипов;
- Техническая поддержка проекта;
- Защита от снятия компонента с производства.



Как с нами связаться

Телефон: 8 (812) 309 58 32 (многоканальный)

Факс: 8 (812) 320-02-42

Электронная почта: org@eplast1.ru

Адрес: 198099, г. Санкт-Петербург, ул. Калинина, дом 2, корпус 4, литера А.