



MICROCHIP

dsPIC30F5015/5016
Data Sheet

High-Performance,
16-bit Digital Signal Controllers

Note the following details of the code protection feature on Microchip devices:

- Microchip products meet the specification contained in their particular Microchip Data Sheet.
- Microchip believes that its family of products is one of the most secure families of its kind on the market today, when used in the intended manner and under normal conditions.
- There are dishonest and possibly illegal methods used to breach the code protection feature. All of these methods, to our knowledge, require using the Microchip products in a manner outside the operating specifications contained in Microchip's Data Sheets. Most likely, the person doing so is engaged in theft of intellectual property.
- Microchip is willing to work with the customer who is concerned about the integrity of their code.
- Neither Microchip nor any other semiconductor manufacturer can guarantee the security of their code. Code protection does not mean that we are guaranteeing the product as "unbreakable."

Code protection is constantly evolving. We at Microchip are committed to continuously improving the code protection features of our products. Attempts to break Microchip's code protection feature may be a violation of the Digital Millennium Copyright Act. If such acts allow unauthorized access to your software or other copyrighted work, you may have a right to sue for relief under that Act.

Information contained in this publication regarding device applications and the like is provided only for your convenience and may be superseded by updates. It is your responsibility to ensure that your application meets with your specifications. MICROCHIP MAKES NO REPRESENTATIONS OR WARRANTIES OF ANY KIND WHETHER EXPRESS OR IMPLIED, WRITTEN OR ORAL, STATUTORY OR OTHERWISE, RELATED TO THE INFORMATION, INCLUDING BUT NOT LIMITED TO ITS CONDITION, QUALITY, PERFORMANCE, MERCHANTABILITY OR FITNESS FOR PURPOSE. Microchip disclaims all liability arising from this information and its use. Use of Microchip devices in life support and/or safety applications is entirely at the buyer's risk, and the buyer agrees to defend, indemnify and hold harmless Microchip from any and all damages, claims, suits, or expenses resulting from such use. No licenses are conveyed, implicitly or otherwise, under any Microchip intellectual property rights.

Trademarks

The Microchip name and logo, the Microchip logo, dsPIC, KEELOQ, KEELOQ logo, MPLAB, PIC, PICmicro, PICSTART, PIC³² logo, rPIC and UNI/O are registered trademarks of Microchip Technology Incorporated in the U.S.A. and other countries.

FilterLab, Hampshire, HI-TECH C, Linear Active Thermistor, MXDEV, MXLAB, SEEVAL and The Embedded Control Solutions Company are registered trademarks of Microchip Technology Incorporated in the U.S.A.

Analog-for-the-Digital Age, Application Maestro, CodeGuard, dsPICDEM, dsPICDEM.net, dsPICworks, dsSPEAK, ECAN, ECONOMONITOR, FanSense, HI-TIDE, In-Circuit Serial Programming, ICSP, Mindi, MiWi, MPASM, MPLAB Certified logo, MPLIB, MPLINK, mTouch, Omniscient Code Generation, PICC, PICC-18, PICDEM, PICDEM.net, PICKit, PICtail, REAL ICE, rLAB, Select Mode, Total Endurance, TSHARC, UniWinDriver, WiperLock and ZENA are trademarks of Microchip Technology Incorporated in the U.S.A. and other countries.

SQTP is a service mark of Microchip Technology Incorporated in the U.S.A.

All other trademarks mentioned herein are property of their respective companies.

© 2011, Microchip Technology Incorporated, Printed in the U.S.A., All Rights Reserved.

 Printed on recycled paper.

ISBN: 978-1-60932-898-6

Microchip received ISO/TS-16949:2002 certification for its worldwide headquarters, design and wafer fabrication facilities in Chandler and Tempe, Arizona; Gresham, Oregon and design centers in California and India. The Company's quality system processes and procedures are for its PIC[®] MCUs and dsPIC[®] DSCs, KEELOQ[®] code hopping devices, Serial EEPROMs, microperipherals, nonvolatile memory and analog products. In addition, Microchip's quality system for the design and manufacture of development systems is ISO 9001:2000 certified.

**QUALITY MANAGEMENT SYSTEM
CERTIFIED BY DNV
== ISO/TS 16949:2002 ==**

High Performance, 16-bit Digital Signal Controllers

Note: This data sheet summarizes features of this group of dsPIC30F devices and is not intended to be a complete reference source. For more information on the CPU, peripherals, register descriptions and general device functionality, refer to the “*dsPIC30F Family Reference Manual*” (DS70046). For more information on the device instruction set and programming, refer to the “*16-bit MCU and DSC Programmer’s Reference Manual*” (DS70157).

High-Performance Modified RISC CPU:

- Modified Harvard architecture
- C compiler optimized instruction set architecture with flexible Addressing modes
- 83 base instructions
- 24-bit wide instructions, 16-bit wide data path
- 66 Kbytes on-chip Flash program space (Instruction words)
- 2 Kbytes of on-chip data RAM
- 1 Kbyte of nonvolatile data EEPROM
- Up to 30 MIPS operation:
 - DC to 40 MHz external clock input
 - 4 MHz-10 MHz oscillator input with PLL active (4x, 8x, 16x)
- 36 interrupt sources:
 - Five external interrupt sources
 - Eight user-selectable priority levels for each interrupt source
 - Four processor trap sources
- 16 x 16-bit working register array

DSP Engine Features:

- Dual data fetch
- Accumulator write back for DSP operations
- Modulo and Bit-Reversed Addressing modes
- Two 40-bit wide accumulators with optional saturation logic
- 17-bit x 17-bit single-cycle hardware fractional/integer multiplier
- All DSP instructions single cycle
- ± 16 -bit single-cycle shift

Peripheral Features:

- High-current sink/source I/O pins: 25 mA/25 mA
- Timer module with programmable prescaler:
 - Five 16-bit timers/counters; optionally pair 16-bit timers into 32-bit timer modules
- 16-bit Capture input functions
- 16-bit Compare/PWM output functions
- 3-wire SPI modules (supports four Frame modes)
- I²C™ module supports Multi-Master/Slave mode and 7-bit/10-bit addressing
- UART module with FIFO Buffers
- CAN module, 2.0B compliant

Motor Control PWM Module Features:

- Eight PWM output channels
 - Complementary or Independent Output modes
 - Edge and Center-Aligned modes
- Four duty cycle generators
- Dedicated time base
- Programmable output polarity
- Dead-Time control for Complementary mode
- Manual output control
- Trigger for A/D conversions

Quadrature Encoder Interface Module Features:

- Phase A, Phase B and Index Pulse input
- 16-bit up/down position counter
- Count direction status
- Position Measurement (x2 and x4) mode
- Programmable digital noise filters on inputs
- Alternate 16-bit Timer/Counter mode
- Interrupt on position counter rollover/underflow

Analog Features:

- 10-bit Analog-to-Digital Converter (ADC) with 4 S/H Inputs:
 - 1 Msps conversion rate
 - 16 input channels
 - Conversion available during Sleep and Idle
- Programmable Brown-out Reset

dsPIC30F5015/5016

Special Microcontroller Features:

- Enhanced Flash program memory:
 - 10,000 erase/write cycle (minimum) for industrial temperature range, 100K (typical)
- Data EEPROM memory:
 - 100,000 erase/write cycle (minimum) for industrial temperature range, 1M (typical)
- Self-reprogrammable under software control
- Power-on Reset (POR), Power-up Timer (PWRT) and Oscillator Start-up Timer (OST)
- Flexible Watchdog Timer (WDT) with on-chip, low-power RC oscillator for reliable operation
- Fail-Safe Clock Monitor operation detects clock failure and switches to on-chip, low-power RC oscillator
- Programmable code protection
- In-Circuit Serial Programming™ (ICSP™) programming capability
- Selectable Power Management modes:
 - Sleep, Idle and Alternate Clock modes

CMOS Technology:

- Low-power, high-speed Flash technology
- Wide operating voltage range (2.5V to 5.5V)
- Industrial and Extended temperature ranges
- Low power consumption

dsPIC30F Motor Control and Power Conversion Family

Device	Pins	Program Mem. Bytes/Instructions	SRAM Bytes	EEPROM Bytes	Timer 16-bit	Input Cap	Output Comp/Std PWM	Motor Control PWM	A/D 10-bit 1 Msps	Quad Enc	UART	SPI	I ² C™	CAN
dsPIC30F5015	64	66K/22K	2048	1024	5	4	4	8 ch	16 ch	Yes	1	2	1	1
dsPIC30F5016	80	66K/22K	2048	1024	5	4	4	8 ch	16 ch	Yes	1	2	1	1

Pin Diagram

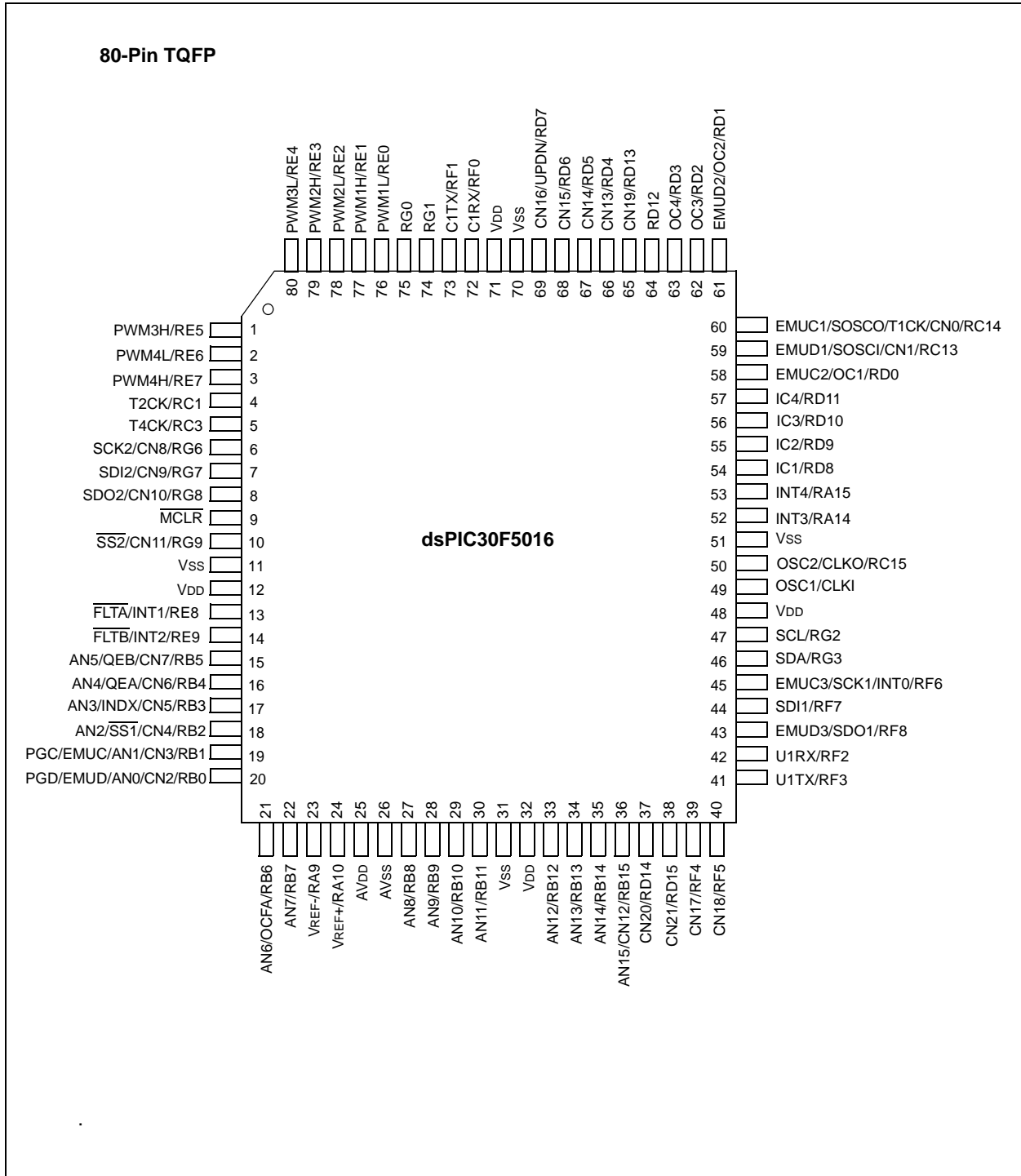

dsPIC30F5015/5016

Pin Diagram

64-Pin TQFP

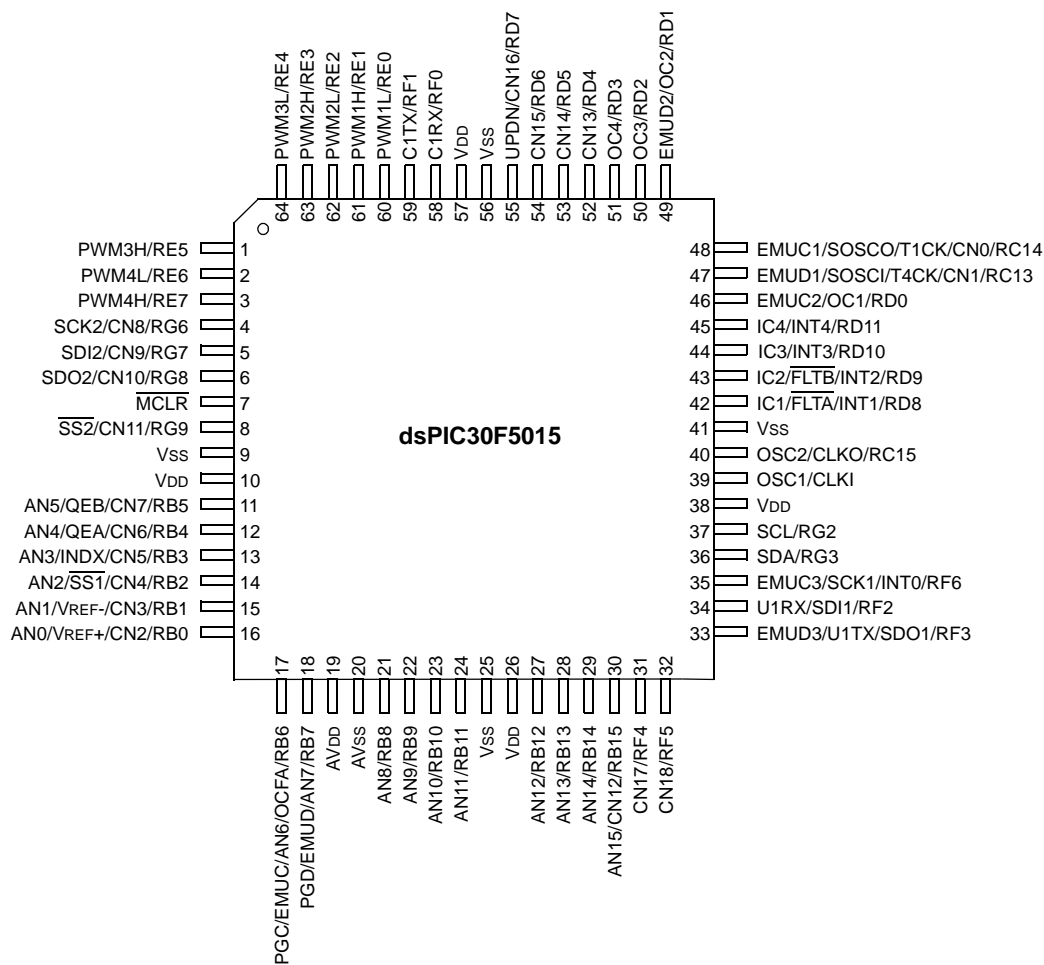

Table of Contents

1.0	Device Overview	9
2.0	CPU Architecture Overview.....	17
3.0	Memory Organization.....	25
4.0	Address Generator Units.....	37
5.0	Interrupts	43
6.0	Flash Program Memory.....	51
7.0	Data EEPROM Memory	57
8.0	I/O Ports	61
9.0	Timer1 Module	67
10.0	Timer2/3 Module	71
11.0	Timer4/5 Module	77
12.0	Input Capture Module	81
13.0	Output Compare Module.....	85
14.0	Quadrature Encoder Interface (QEI) Module	91
15.0	Motor Control PWM Module.....	97
16.0	SPI Module.....	109
17.0	I2C™ Module	113
18.0	Universal Asynchronous Receiver Transmitter (UART) Module	121
19.0	CAN Module.....	129
20.0	10-bit High-Speed Analog-to-Digital Converter (ADC) Module	139
21.0	System Integration	151
22.0	Instruction Set Summary	165
23.0	Development Support.....	173
24.0	Electrical Characteristics.....	177
25.0	Packaging Information.....	217
	Appendix A: Revision History.....	223
	Index	225
	The Microchip Web Site.....	231
	Customer Change Notification Service	231
	Customer Support.....	231
	Reader Response	232
	Product Identification System	233

TO OUR VALUED CUSTOMERS

It is our intention to provide our valued customers with the best documentation possible to ensure successful use of your Microchip products. To this end, we will continue to improve our publications to better suit your needs. Our publications will be refined and enhanced as new volumes and updates are introduced.

If you have any questions or comments regarding this publication, please contact the Marketing Communications Department via E-mail at docerrors@microchip.com or fax the **Reader Response Form** in the back of this data sheet to (480) 792-4150. We welcome your feedback.

Most Current Data Sheet

To obtain the most up-to-date version of this data sheet, please register at our Worldwide Web site at:

<http://www.microchip.com>

You can determine the version of a data sheet by examining its literature number found on the bottom outside corner of any page. The last character of the literature number is the version number, (e.g., DS30000A is version A of document DS30000).

Errata

An errata sheet, describing minor operational differences from the data sheet and recommended workarounds, may exist for current devices. As device/documentation issues become known to us, we will publish an errata sheet. The errata will specify the revision of silicon and revision of document to which it applies.

To determine if an errata sheet exists for a particular device, please check with one of the following:

- Microchip's Worldwide Web site; <http://www.microchip.com>
- Your local Microchip sales office (see last page)

When contacting a sales office, please specify which device, revision of silicon and data sheet (include literature number) you are using.

Customer Notification System

Register on our web site at www.microchip.com to receive the most current information on all of our products.

dsPIC30F5015/5016

NOTES:

1.0 DEVICE OVERVIEW

Note: This data sheet summarizes features of this group of dsPIC30F devices and is not intended to be a complete reference source. For more information on the CPU, peripherals, register descriptions and general device functionality, refer to the “*dsPIC30F Family Reference Manual*” (DS70046). For more information on the device instruction set and programming, refer to the “*16-bit MCU and DSC Programmer’s Reference Manual*” (DS70157).

This document contains device specific information for the dsPIC30F5015/5016 devices. The dsPIC30F devices contain extensive Digital Signal Processor (DSP) functionality within a high-performance 16-bit microcontroller (MCU) architecture.

[Figure 1-1](#) is a block diagram of the dsPIC30F5015 device. Following the block diagram, [Table 1-1](#) provides a brief description of the device I/O pinout and the functions that are multiplexed to the port pins on the dsPIC30F5015.

[Figure 1-2](#) is a block diagram of the dsPIC30F5016 device. Following the block diagram, [Table 1-2](#) provides a brief description of the device I/O pinout and the functions that are multiplexed to the port pins on the dsPIC30F5016.

dsPIC30F5015/5016

Table 1-1 provides a brief description of the device I/O pinout and the functions that are multiplexed to the port pins on the dsPIC30F5015 device. Multiple functions may exist on one port pin. When multiplexing occurs, the peripheral module's functional requirements may force an override of the data direction of the port pin.

TABLE 1-1: I/O PIN DESCRIPTIONS FOR dsPIC30F5015

Pin Name	Pin Type	Buffer Type	Description
AN0-AN15	I	Analog	Analog input channels. AN0 and AN1 are also used for device programming data and clock inputs, respectively.
AVDD	P	P	Positive supply for analog module. This pin must be connected at all times.
AVSS	P	P	Ground reference for analog module. This pin must be connected at all times.
CLKI	I	ST/CMOS	External clock source input. Always associated with OSC1 pin function.
CLKO	O	—	Oscillator crystal output. Connects to crystal or resonator in Crystal Oscillator mode. Optionally functions as CLKO in RC and EC modes. Always associated with OSC2 pin function.
CN0-CN18	I	ST	Input change notification inputs. Can be software programmed for internal weak pull-ups on all inputs.
C1RX	I	ST	CAN1 bus receive pin.
C1TX	O	—	CAN1 bus transmit pin.
EMUD	I/O	ST	ICD Primary Communication Channel data input/output pin.
EMUC	I/O	ST	ICD Primary Communication Channel clock input/output pin.
EMUD1	I/O	ST	ICD Secondary Communication Channel data input/output pin.
EMUC1	I/O	ST	ICD Secondary Communication Channel clock input/output pin.
EMUD2	I/O	ST	ICD Tertiary Communication Channel data input/output pin.
EMUC2	I/O	ST	ICD Tertiary Communication Channel clock input/output pin.
EMUD3	I/O	ST	ICD Quaternary Communication Channel data input/output pin.
EMUC3	I/O	ST	ICD Quaternary Communication Channel clock input/output pin.
IC1-IC4	I	ST	Capture inputs 1 through 4.
INDX	I	ST	Quadrature Encoder Index Pulse input.
QEA	I	ST	Quadrature Encoder Phase A input in QE1 mode.
QEB	I	ST	Quadrature Encoder Phase B input in QE1 mode.
UPDN	O	—	Auxiliary Timer External Clock/Gate input in Timer mode. Position Up/Down Counter Direction State.
INT0	I	ST	External interrupt 0.
INT1	I	ST	External interrupt 1.
INT2	I	ST	External interrupt 2.
INT3	I	ST	External interrupt 3.
INT4	I	ST	External interrupt 4.
FLTA	I	ST	PWM Fault A input.
FLTB	I	ST	PWM Fault B input.
PWM1L	O	—	PWM1 Low output.
PWM1H	O	—	PWM1 High output.
PWM2L	O	—	PWM2 Low output.
PWM2H	O	—	PWM2 High output.
PWM3L	O	—	PWM3 Low output.
PWM3H	O	—	PWM3 High output.
PWM4L	O	—	PWM4 Low output.
PWM4H	O	—	PWM4 High output.

Legend: CMOS = CMOS compatible input or output Analog = Analog input
 ST = Schmitt Trigger input with CMOS levels O = Output
 I = Input P = Power

dsPIC30F5015/5016

TABLE 1-1: I/O PIN DESCRIPTIONS FOR dsPIC30F5015 (CONTINUED)

Pin Name	Pin Type	Buffer Type	Description
MCLR	I/P	ST	Master Clear (Reset) input or programming voltage input. This pin is an active-low Reset to the device.
OCFA OC1-OC4	I O	ST —	Compare Fault A input (for Compare channels 1, 2, 3 and 4). Compare outputs 1 through 4.
OSC1 OSC2	I I/O	ST/CMOS —	Oscillator crystal input. ST buffer when configured in RC mode; CMOS otherwise. Oscillator crystal output. Connects to crystal or resonator in Crystal Oscillator mode. Optionally functions as CLKO in RC and EC modes.
PGD PGC	I/O I	ST ST	In-Circuit Serial Programming™ data input/output pin. In-Circuit Serial Programming clock input pin.
RB0-RB15	I/O	ST	PORTB is a bidirectional I/O port.
RC13-RC15	I/O	ST	PORTC is a bidirectional I/O port.
RD0-RD11	I/O	ST	PORTD is a bidirectional I/O port.
RE0-RE7	I/O	ST	PORTE is a bidirectional I/O port.
RF0-RF6	I/O	ST	PORTF is a bidirectional I/O port.
RG2-RG3 RG6-RG9	I/O I/O	ST ST	PORTG is a bidirectional I/O port.
SCK1 SDI1 SDO1 SS1 SCK2 SDI2 SDO2 SS2	I/O I O I I/O I O I	ST ST — ST ST ST — ST	Synchronous serial clock input/output for SPI1. SPI1 Data In. SPI1 Data Out. SPI1 Slave Synchronization. Synchronous serial clock input/output for SPI2. SPI2 Data In. SPI2 Data Out. SPI2 Slave Synchronization.
SCL SDA	I/O I/O	ST ST	Synchronous serial clock input/output for I ² C™. Synchronous serial data input/output for I ² C.
SOSCO SOSCI	O I	— ST/CMOS	32 kHz low-power oscillator crystal output. 32 kHz low-power oscillator crystal input. ST buffer when configured in RC mode; CMOS otherwise.
T1CK T4CK	I I	ST ST	Timer1 external clock input. Timer4 external clock input.
U1RX U1TX	I O	ST —	UART1 Receive. UART1 Transmit.
VDD	P	—	Positive supply for logic and I/O pins.
VSS	P	—	Ground reference for logic and I/O pins.
VREF+	I	Analog	Analog Voltage Reference (High) input.
VREF-	I	Analog	Analog Voltage Reference (Low) input.

Legend: CMOS = CMOS compatible input or output Analog = Analog input
 ST = Schmitt Trigger input with CMOS levels O = Output
 I = Input P = Power

FIGURE 1-2: dsPIC30F5016 BLOCK DIAGRAM

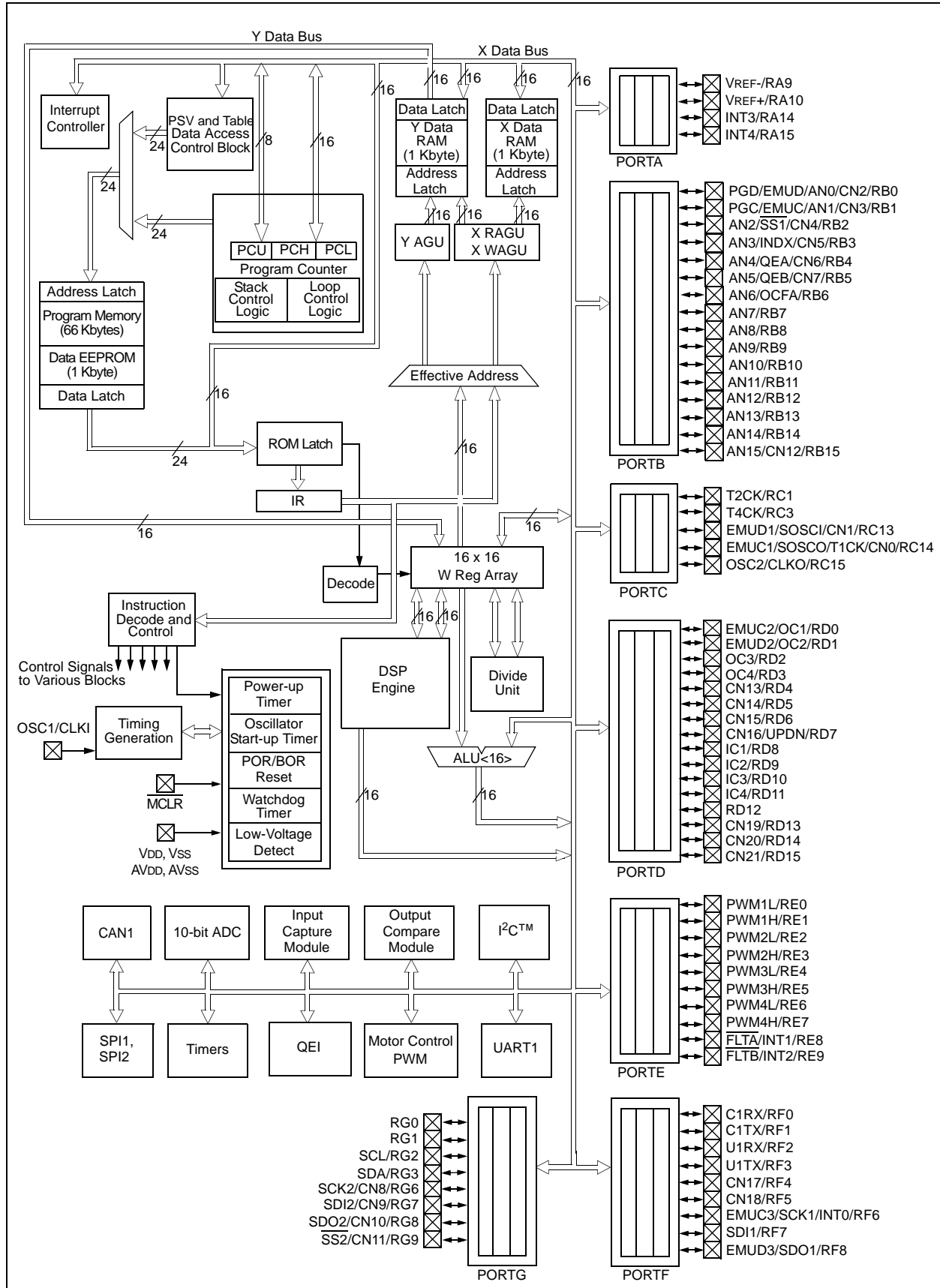

dsPIC30F5015/5016

Table 1-1 provides a brief description of the device I/O pinout and the functions that are multiplexed to the port pins on the dsPIC30F5016. Multiple functions may exist on one port pin. When multiplexing occurs, the peripheral module's functional requirements may force an override of the data direction of the port pin.

TABLE 1-2: I/O PIN DESCRIPTIONS FOR dsPIC30F5016

Pin Name	Pin Type	Buffer Type	Description
AN0-AN15	I	Analog	Analog input channels. AN0 and AN1 are also used for device programming data and clock inputs, respectively.
AVDD	P	P	Positive supply for analog module. This pin must be connected at all times.
AVSS	P	P	Ground reference for analog module. This pin must be connected at all times.
CLKI	I	ST/CMOS	External clock source input. Always associated with OSC1 pin function.
CLKO	O	—	Oscillator crystal output. Connects to crystal or resonator in Crystal Oscillator mode. Optionally functions as CLKO in RC and EC modes. Always associated with OSC2 pin function.
CN0-CN21	I	ST	Input change notification inputs. Can be software programmed for internal weak pull-ups on all inputs.
C1RX	I	ST	CAN1 bus receive pin.
C1TX	O	—	CAN1 bus transmit pin.
EMUD	I/O	ST	ICD Primary Communication Channel data input/output pin.
EMUC	I/O	ST	ICD Primary Communication Channel clock input/output pin.
EMUD1	I/O	ST	ICD Secondary Communication Channel data input/output pin.
EMUC1	I/O	ST	ICD Secondary Communication Channel clock input/output pin.
EMUD2	I/O	ST	ICD Tertiary Communication Channel data input/output pin.
EMUC2	I/O	ST	ICD Tertiary Communication Channel clock input/output pin.
EMUD3	I/O	ST	ICD Quaternary Communication Channel data input/output pin.
EMUC3	I/O	ST	ICD Quaternary Communication Channel clock input/output pin.
IC1-IC4	I	ST	Capture inputs 1 through 8.
INDX	I	ST	Quadrature Encoder Index Pulse input.
QEA	I	ST	Quadrature Encoder Phase A input in QE1 mode.
QEB	I	ST	Quadrature Encoder Phase B input in QE1 mode.
UPDN	O	—	Auxiliary Timer External Clock/Gate input in Timer mode. Position Up/Down Counter Direction State.
INT0	I	ST	External interrupt 0.
INT1	I	ST	External interrupt 1.
INT2	I	ST	External interrupt 2.
INT3	I	ST	External interrupt 3.
INT4	I	ST	External interrupt 4.
FLTA	I	ST	PWM Fault A input.
FLTB	I	ST	PWM Fault B input.
PWM1L	O	—	PWM1 Low output.
PWM1H	O	—	PWM1 High output.
PWM2L	O	—	PWM2 Low output.
PWM2H	O	—	PWM2 High output.
PWM3L	O	—	PWM3 Low output.
PWM3H	O	—	PWM3 High output.
PWM4L	O	—	PWM4 Low output.
PWM4H	O	—	PWM4 High output.

Legend: CMOS = CMOS compatible input or output Analog = Analog input
 ST = Schmitt Trigger input with CMOS levels O = Output
 I = Input P = Power

dsPIC30F5015/5016

TABLE 1-2: I/O PIN DESCRIPTIONS FOR dsPIC30F5016 (CONTINUED)

Pin Name	Pin Type	Buffer Type	Description
MCLR	I/P	ST	Master Clear (Reset) input or programming voltage input. This pin is an active-low Reset to the device.
OCFA	I	ST	Compare Fault A input (for Compare channels 1, 2, 3 and 4).
OCFB	I	ST	Compare Fault B input (for Compare channels 5, 6, 7 and 8).
OC1-OC4	O	—	Compare outputs 1 through 4.
OSC1	I	ST/CMOS	Oscillator crystal input. ST buffer when configured in RC mode; CMOS otherwise.
OSC2	I/O	—	Oscillator crystal output. Connects to crystal or resonator in Crystal Oscillator mode. Optionally functions as CLK0 in RC and EC modes.
PGD	I/O	ST	In-Circuit Serial Programming™ data input/output pin.
PGC	I	ST	In-Circuit Serial Programming clock input pin.
RA9-RA10	I/O	ST	PORTA is a bidirectional I/O port.
RA14-RA15	I/O	ST	
RB0-RB15	I/O	ST	PORTB is a bidirectional I/O port.
RC1	I/O	ST	PORTC is a bidirectional I/O port.
RC3	I/O	ST	
RC13-RC15	I/O	ST	
RD0-RD15	I/O	ST	PORTD is a bidirectional I/O port.
RE0-RE9	I/O	ST	PORTE is a bidirectional I/O port.
RF0-RF8	I/O	ST	PORTF is a bidirectional I/O port.
RG0-RG3	I/O	ST	PORTG is a bidirectional I/O port.
RG6-RG9	I/O	ST	
SCK1	I/O	ST	Synchronous serial clock input/output for SPI1.
SDI1	I	ST	SPI1 Data In.
SDO1	O	—	SPI1 Data Out.
SS1	I	ST	SPI1 Slave Synchronization.
SCK2	I/O	ST	Synchronous serial clock input/output for SPI2.
SDI2	I	ST	SPI2 Data In.
SDO2	O	—	SPI2 Data Out.
SS2	I	ST	SPI2 Slave Synchronization.
SCL	I/O	ST	Synchronous serial clock input/output for I ² C™.
SDA	I/O	ST	Synchronous serial data input/output for I ² C.
SOSCO	O	—	32 kHz low-power oscillator crystal output.
SOSCI	I	ST/CMOS	32 kHz low-power oscillator crystal input. ST buffer when configured in RC mode; CMOS otherwise.
T1CK	I	ST	Timer1 external clock input.
T2CK	I	ST	Timer2 external clock input.
T4CK	I	ST	Timer4 external clock input.
U1RX	I	ST	UART1 Receive.
U1TX	O	—	UART1 Transmit.
VDD	P	—	Positive supply for logic and I/O pins.
VSS	P	—	Ground reference for logic and I/O pins.
VREF+	I	Analog	Analog Voltage Reference (High) input.
VREF-	I	Analog	Analog Voltage Reference (Low) input.

Legend: CMOS = CMOS compatible input or output Analog = Analog input
 ST = Schmitt Trigger input with CMOS levels O = Output
 I = Input P = Power

dsPIC30F5015/5016

NOTES:

2.0 CPU ARCHITECTURE OVERVIEW

Note: This data sheet summarizes features of this group of dsPIC30F devices and is not intended to be a complete reference source. For more information on the CPU, peripherals, register descriptions and general device functionality, refer to the “*dsPIC30F Family Reference Manual*” (DS70046). For more information on the device instruction set and programming, refer to the “*16-bit MCU and DSC Programmer’s Reference Manual*” (DS70157).

This document provides a summary of the dsPIC30F5015/5016 CPU and peripheral function. For a complete description of this functionality, please refer to the “*dsPIC30F Family Reference Manual*” (DS70046).

2.1 Core Overview

The core has a 24-bit instruction word. The Program Counter (PC) is 23 bits wide with the Least Significant bit (LSb) always clear (see [Section 3.1 “Program Address Space”](#)), and the Most Significant bit (MSb) is ignored during normal program execution, except for certain specialized instructions. Thus, the PC can address up to 4M instruction words of user program space. An instruction prefetch mechanism is used to help maintain throughput. Program loop constructs, free from loop count management overhead, are supported using the `DO` and `REPEAT` instructions, both of which are interruptible at any point.

The working register array consists of 16x16-bit registers, each of which can act as data, address or offset registers. One working register (W15) operates as a software Stack Pointer for interrupts and calls.

The data space is 64 Kbytes (32K words) and is split into two blocks, referred to as X and Y data memory. Each block has its own independent Address Generation Unit (AGU). Most instructions operate solely through the X memory AGU, which provides the appearance of a single unified data space. The Multiply-Accumulate (MAC) class of dual source DSP instructions operate through both the X and Y AGUs, splitting the data address space into two parts (see [Section 3.2 “Data Address Space”](#)). The X and Y data space boundary is device specific and cannot be altered by the user. Each data word consists of 2 bytes, and most instructions can address data either as words or bytes.

There are two methods of accessing data stored in program memory:

- The upper 32 Kbytes of data space memory can be mapped into the lower half (user space) of program space at any 16K program word boundary, defined by the 8-bit Program Space Visibility Page register (PSVPAG). This lets any instruction access program space as if it were data space, with a limitation that the access requires an additional cycle. Moreover, only the lower 16 bits of each instruction word can be accessed using this method.
- Linear indirect access of 32K word pages within program space is also possible using any working register, via table read and write instructions. Table read and write instructions can be used to access all 24 bits of an instruction word.

Overhead-free circular buffers (Modulo Addressing) are supported in both X and Y address spaces. This is primarily intended to remove the loop overhead for DSP algorithms.

The X AGU also supports Bit-Reversed Addressing on destination effective addresses, to greatly simplify input or output data reordering for radix-2 FFT algorithms. Refer to [Section 4.0 “Address Generator Units”](#) for details on Modulo and Bit-Reversed Addressing.

The core supports Inherent (no operand), Relative, Literal, Memory Direct, Register Direct, Register Indirect, Register Offset and Literal Offset Addressing modes. Instructions are associated with predefined addressing modes, depending upon their functional requirements.

For most instructions, the core is capable of executing a data (or program data) memory read, a working register (data) read, a data memory write and a program (instruction) memory read per instruction cycle. As a result, 3-operand instructions are supported, allowing $C = A + B$ operations to be executed in a single cycle.

A DSP engine has been included to significantly enhance the core arithmetic capability and throughput. It features a high-speed 17-bit by 17-bit multiplier, a 40-bit ALU, two 40-bit saturating accumulators and a 40-bit bidirectional barrel shifter. Data in the accumulator or any working register can be shifted up to 16 bits right or 16 bits left in a single cycle. The DSP instructions operate seamlessly with all other instructions and have been designed for optimal real-time performance. The MAC class of instructions can concurrently fetch two data operands from memory, while multiplying two W registers. To enable this concurrent fetching of data operands, the data space has been split for these instructions and linear for all others. This has been achieved in a transparent and flexible manner, by dedicating certain working registers to each address space for the MAC class of instructions.

dsPIC30F5015/5016

The core does not support a multi-stage instruction pipeline. However, a single stage instruction prefetch mechanism is used, which accesses and partially decodes instructions a cycle ahead of execution, in order to maximize available execution time. Most instructions execute in a single cycle, with certain exceptions.

The core features a vectored exception processing structure for traps and interrupts, with 62 independent vectors. The exceptions consist of up to 8 traps (of which 4 are reserved) and 54 interrupts. Each interrupt is prioritized based on a user assigned priority between 1 and 7 (1 being the lowest priority and 7 being the highest) in conjunction with a predetermined 'natural order'. Traps have fixed priorities, ranging from 8 to 15.

2.2 Programmer's Model

The programmer's model is shown in Figure 2-1 and consists of 16x16-bit working registers (W0 through W15), 2x40-bit accumulators (ACCA and ACCB), STATUS register (SR), Data Table Page register (TBLPAG), Program Space Visibility Page register (PSVPAG), DO and REPEAT registers (DOSTART, DOEND, DCOUNT and RCOUNT) and Program Counter (PC). The working registers can act as data, address or offset registers. All registers are memory mapped. W0 acts as the W register for file register addressing.

Some of these registers have a shadow register associated with each of them, as shown in Figure 2-1. The shadow register is used as a temporary holding register and can transfer its contents to or from its host register upon the occurrence of an event. None of the shadow registers are accessible directly. The following rules apply for transfer of registers into and out of shadows.

- PUSH.S and POP.S
W0, W1, W2, W3, SR (DC, N, OV, Z and C bits only) are transferred.
- DO instruction
DOSTART, DOEND, DCOUNT shadows are pushed on loop start, and popped on loop end.

When a byte operation is performed on a working register, only the Least Significant Byte (LSB) of the target register is affected. However, a benefit of memory mapped working registers is that both the Least and Most Significant Bytes (MSBs) can be manipulated through byte-wide data memory space accesses.

2.2.1 SOFTWARE STACK POINTER/ FRAME POINTER

The dsPIC DSC devices contain a software stack. W15 is the dedicated software Stack Pointer (SP), and will be automatically modified by exception processing and subroutine calls and returns. However, W15 can be referenced by any instruction in the same manner as all other W registers. This simplifies the reading, writing and manipulation of the Stack Pointer (e.g., creating stack frames).

Note: In order to protect against misaligned stack accesses, W15<0> is always clear.

W15 is initialized to 0x0800 during a Reset. The user may reprogram the SP during initialization to any location within data space.

W14 has been dedicated as a Stack Frame Pointer as defined by the LNK and ULNK instructions. However, W14 can be referenced by any instruction in the same manner as all other W registers.

2.2.2 STATUS REGISTER

The dsPIC DSC core has a 16-bit STATUS register (SR), the LSB of which is referred to as the SR Low Byte (SRL) and the MSB as the SR High Byte (SRH). See Figure 2-1 for SR layout.

SRL contains all the MCU ALU operation Status flags (including the Z bit), as well as the CPU Interrupt Priority Level Status bits, IPL<2:0>, and the Repeat Active Status bit, RA. During exception processing, SRL is concatenated with the MSB of the PC to form a complete word value which is then stacked.

The upper byte of the SR register contains the DSP Adder/Subtractor Status bits, the DO Loop Active bit (DA) and the Digit Carry (DC) Status bit.

2.2.3 PROGRAM COUNTER

The Program Counter is 23 bits wide. Bit 0 is always clear. Therefore, the PC can address up to 4M instruction words.

FIGURE 2-1: dsPIC30F5015/5016 PROGRAMMER'S MODEL

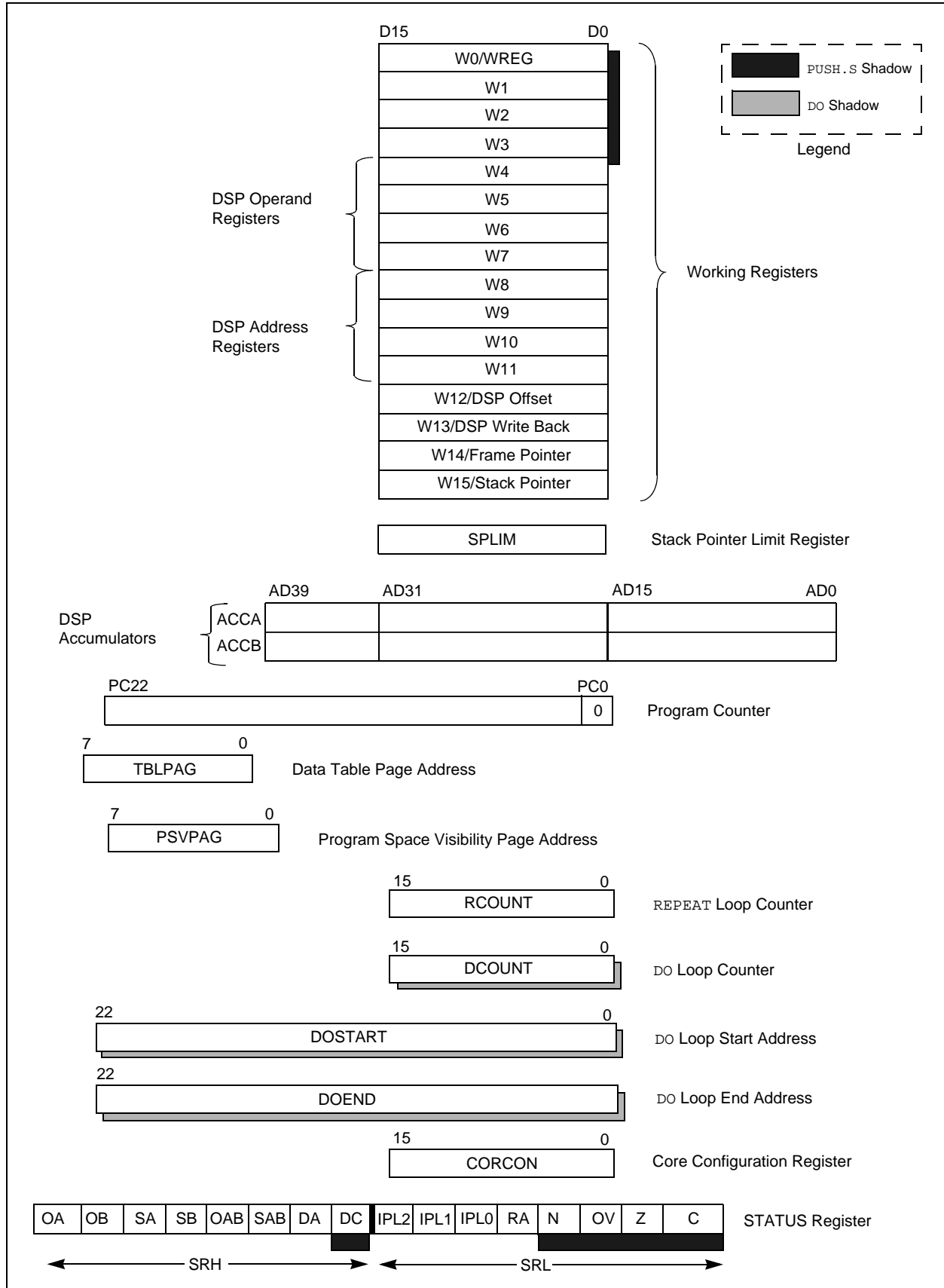

dsPIC30F5015/5016

2.3 Divide Support

The dsPIC DSC devices feature a 16/16-bit signed fractional divide operation, as well as 32/16-bit and 16/16-bit signed and unsigned integer divide operations, in the form of single instruction iterative divides. The following instructions and data sizes are supported:

- `DIVF` – 16/16 signed fractional divide
- `DIV.sd` – 32/16 signed divide
- `DIV.ud` – 32/16 unsigned divide
- `DIV.sw` – 16/16 signed divide
- `DIV.uw` – 16/16 unsigned divide

The divide instructions must be executed within a `REPEAT` loop. Any other form of execution (e.g. a series of discrete divide instructions) will not function correctly because the instruction flow depends on `RCOUNT`. The divide instruction does not automatically set up the `RCOUNT` value, and it must, therefore, be explicitly and correctly specified in the `REPEAT` instruction, as shown in [Table 2-1](#) (`REPEAT` will execute the target instruction {operand value+1} times). The `REPEAT` loop count must be set up for 18 iterations of the `DIV/DIVF` instruction. Thus, a complete divide operation requires 19 cycles.

Note: The divide flow is interruptible. However, the user needs to save the context as appropriate.

TABLE 2-1: DIVIDE INSTRUCTIONS

Instruction	Function
<code>DIVF</code>	Signed fractional divide: $Wm/Wn \rightarrow W0$; $Rem \rightarrow W1$
<code>DIV.sd</code>	Signed divide: $(Wm+1:Wm)/Wn \rightarrow W0$; $Rem \rightarrow W1$
<code>DIV.ud</code>	Unsigned divide: $(Wm+1:Wm)/Wn \rightarrow W0$; $Rem \rightarrow W1$
<code>DIV.sw</code>	Signed divide: $Wm/Wn \rightarrow W0$; $Rem \rightarrow W1$
<code>DIV.uw</code>	Unsigned divide: $Wm/Wn \rightarrow W0$; $Rem \rightarrow W1$

2.4 DSP Engine

The DSP engine consists of a high-speed 17-bit x 17-bit multiplier, a barrel shifter, and a 40-bit adder/subtractor (with two target accumulators, round and saturation logic).

The dsPIC30F devices have a single instruction flow which can execute either DSP or MCU instructions. Many of the hardware resources are shared between the DSP and MCU instructions. For example, the instruction set has both DSP and MCU multiply instructions which use the same hardware multiplier.

The DSP engine also has the capability to perform inherent accumulator-to-accumulator operations, which require no additional data. These instructions are `ADD`, `SUB` and `NEG`.

The DSP engine has various options selected through various bits in the CPU Core Configuration register (`CORCON`), as listed below:

- Fractional or Integer DSP Multiply (`IF`).
- Signed or Unsigned DSP Multiply (`US`).
- Conventional or Convergent Rounding (`RND`).
- Automatic Saturation On/Off for `ACCA` (`SATA`).
- Automatic Saturation On/Off for `ACCB` (`SATB`).
- Automatic Saturation On/Off for Writes to Data Memory (`SATDW`).
- Accumulator Saturation mode Selection (`ACCSAT`).

Note: For `CORCON` layout, see [Table 3-3](#).

A block diagram of the DSP engine is shown in [Figure 2-2](#).

TABLE 2-2: DSP INSTRUCTION SUMMARY

Instruction	Algebraic Operation
<code>CLR</code>	$A = 0$
<code>ED</code>	$A = (x - y)^2$
<code>EDAC</code>	$A = A + (x - y)^2$
<code>MAC</code>	$A = A + (x * y)$
<code>MOVSAC</code>	No change in A
<code>MPY</code>	$A = x * y$
<code>MPY.N</code>	$A = -x * y$
<code>MSC</code>	$A = A - x * y$

FIGURE 2-2: DSP ENGINE BLOCK DIAGRAM

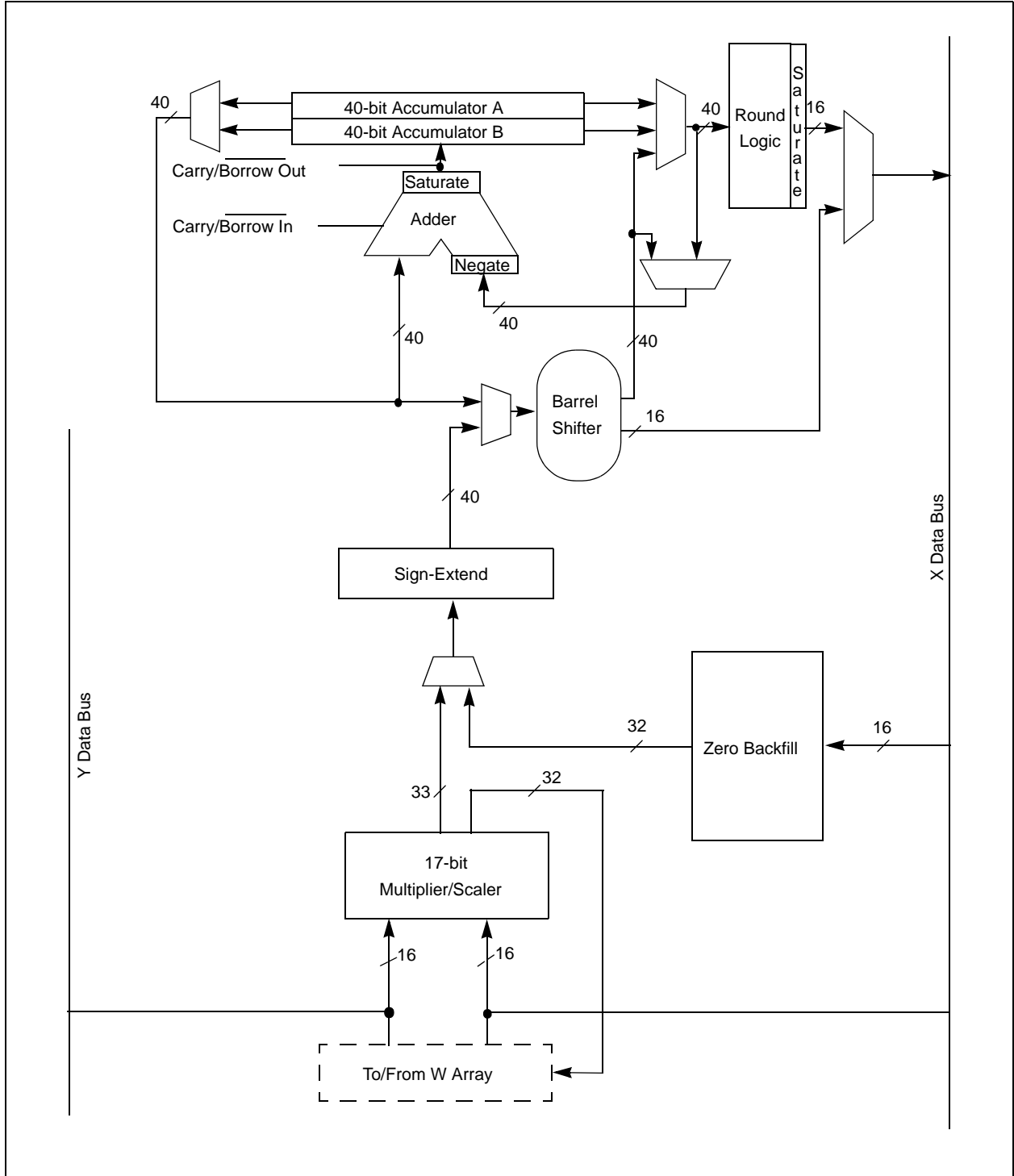

dsPIC30F5015/5016

2.4.1 MULTIPLIER

The 17x17-bit multiplier is capable of signed or unsigned operations and can multiplex its output using a scaler to support either 1.31 fractional (Q31) or 32-bit integer results. Unsigned operands are zero-extended into the 17th bit of the multiplier input value. Signed operands are sign-extended into the 17th bit of the multiplier input value. The output of the 17x17-bit multiplier/scaler is a 33-bit value, which is sign-extended to 40 bits. Integer data is inherently represented as a signed two's complement value, where the MSB is defined as a sign bit. Generally speaking, the range of an N-bit two's complement integer is -2^{N-1} to $2^{N-1} - 1$. For a 16-bit integer, the data range is -32768 (0x8000) to 32767 (0x7FFF), including 0. For a 32-bit integer, the data range is -2,147,483,648 (0x8000 0000) to 2,147,483,645 (0x7FFF FFFF).

When the multiplier is configured for fractional multiplication, the data is represented as a two's complement fraction, where the MSB is defined as a sign bit and the radix point is implied to lie just after the sign bit (QX format). The range of an N-bit two's complement fraction with this implied radix point is -1.0 to $(1 - 2^{1-N})$. For a 16-bit fraction, the Q15 data range is -1.0 (0x8000) to 0.999969482 (0x7FFF), including 0 and has a precision of 3.01518×10^{-5} . In Fractional mode, a 16x16 multiply operation generates a 1.31 product, which has a precision of 4.65661×10^{-10} .

The same multiplier is used to support the MCU multiply instructions, which include integer 16-bit signed, unsigned and mixed sign multiplies.

The MUL instruction may be directed to use byte or word-sized operands. Byte operands will direct a 16-bit result, and word operands will direct a 32-bit result to the specified register(s) in the W array.

2.4.2 DATA ACCUMULATORS AND ADDER/SUBTRACTER

The data accumulator consists of a 40-bit adder/subtractor with automatic sign extension logic. It can select one of two accumulators (A or B) as its pre-accumulation source and post-accumulation destination. For the ADD and LAC instructions, the data to be accumulated or loaded can be optionally scaled via the barrel shifter, prior to accumulation.

2.4.2.1 Adder/Subtractor, Overflow and Saturation

The adder/subtractor is a 40-bit adder with an optional zero input into one side and either true or complement data into the other input. In the case of addition, the carry/borrow input is active-high and the other input is true data (not complemented), whereas in the case of subtraction, the carry/borrow input is active-low and the other input is complemented. The adder/subtractor generates Overflow Status bits, SA/SB and OA/OB, which are latched and reflected in the STATUS register.

- Overflow from bit 39: this is a catastrophic overflow in which the sign of the accumulator is destroyed.
- Overflow into guard bits 32 through 39: this is a recoverable overflow. This bit is set whenever all the guard bits are not identical to each other.

The adder has an additional saturation block which controls accumulator data saturation, if selected. It uses the result of the adder, the Overflow Status bits described above, and the SATA/B (CORCON<7:6>) and ACCSAT (CORCON<4>) mode control bits to determine when and to what value to saturate.

Six STATUS register bits have been provided to support saturation and overflow; they are:

1. OA:
ACCA overflowed into guard bits
2. OB:
ACCB overflowed into guard bits
3. SA:
ACCA saturated (bit 31 overflow and saturation)
or
ACCA overflowed into guard bits and saturated (bit 39 overflow and saturation)
4. SB:
ACCB saturated (bit 31 overflow and saturation)
or
ACCB overflowed into guard bits and saturated (bit 39 overflow and saturation)
5. OAB:
Logical OR of OA and OB
6. SAB:
Logical OR of SA and SB

The OA and OB bits are modified each time data passes through the adder/subtractor. When set, they indicate that the most recent operation has overflowed into the accumulator guard bits (bits 32 through 39). The OA and OB bits can also optionally generate an arithmetic warning trap when set and the corresponding overflow trap flag enable bit (OVATE, OVBTE) in the INTCON1 register (refer to [Section 5.0 "Interrupts"](#)) is set. This allows the user to take immediate action, for example, to correct system gain.

The SA and SB bits are modified each time data passes through the adder/subtractor, but can only be cleared by the user. When set, they indicate that the accumulator has overflowed its maximum range (bit 31 for 32-bit saturation, or bit 39 for 40-bit saturation) and will be saturated (if saturation is enabled). When saturation is not enabled, SA and SB default to bit 39 overflow and thus indicate that a catastrophic overflow has occurred. If the COVTE bit in the INTCON1 register is set, SA and SB bits will generate an arithmetic warning trap when saturation is disabled.

The Overflow and Saturation Status bits can optionally be viewed in the STATUS register (SR) as the logical OR of OA and OB (in bit OAB) and the logical OR of SA and SB (in bit SAB). This allows programmers to check one bit in the STATUS register to determine if either accumulator has overflowed, or one bit to determine if either accumulator has saturated. This would be useful for complex number arithmetic which typically uses both the accumulators.

The device supports three Saturation and Overflow modes.

1. **Bit 39 Overflow and Saturation:**
When bit 39 overflow and saturation occurs, the saturation logic loads the maximally positive 9.31 (0x7FFFFFFF) or maximally negative 9.31 value (0x80000000) into the target accumulator. The SA or SB bit is set and remains set until cleared by the user. This is referred to as 'super saturation' and provides protection against erroneous data or unexpected algorithm problems (e.g., gain calculations).
2. **Bit 31 Overflow and Saturation:**
When bit 31 overflow and saturation occurs, the saturation logic then loads the maximally positive 1.31 value (0x007FFFFFFF) or maximally negative 1.31 value (0x00800000) into the target accumulator. The SA or SB bit is set and remains set until cleared by the user. When this Saturation mode is in effect, the guard bits are not used (so the OA, OB or OAB bits are never set).
3. **Bit 39 Catastrophic Overflow**
The bit 39 Overflow Status bit from the adder is used to set the SA or SB bit, which remain set until cleared by the user. No saturation operation is performed and the accumulator is allowed to overflow (destroying its sign). If the COVTE bit in the INTCON1 register is set, a catastrophic overflow can initiate a trap exception.

2.4.2.2 Accumulator 'Write Back'

The MAC class of instructions (with the exception of MPY, MPY.N, ED and EDAC) can optionally write a rounded version of the high word (bits 31 through 16) of the accumulator that is not targeted by the instruction into data space memory. The write is performed across the X bus into combined X and Y address space. The following addressing modes are supported:

- W13, Register Direct:
The rounded contents of the non-target accumulator are written into W13 as a 1.15 fraction.
- [W13]+ = 2, Register Indirect with Post-Increment:
The rounded contents of the non-target accumulator are written into the address pointed to by W13 as a 1.15 fraction. W13 is then incremented by 2 (for a word write).

2.4.2.3 Round Logic

The round logic is a combinational block, which performs a conventional (biased) or convergent (unbiased) round function during an accumulator write (store). The Round mode is determined by the state of the RND bit in the CORCON register. It generates a 16-bit, 1.15 data value which is passed to the data space write saturation logic. If rounding is not indicated by the instruction, a truncated 1.15 data value is stored and the least significant word (lsw) is simply discarded.

Conventional rounding takes bit 15 of the accumulator, zero-extends it and adds it to the ACCxH word (bits 16 through 31 of the accumulator). If the ACCxL word (bits 0 through 15 of the accumulator) is between 0x8000 and 0xFFFF (0x8000 included), ACCxH is incremented. If ACCxL is between 0x0000 and 0x7FFF, ACCxH is left unchanged. A consequence of this algorithm is that over a succession of random rounding operations, the value will tend to be biased slightly positive.

Convergent (or unbiased) rounding operates in the same manner as conventional rounding, except when ACCxL equals 0x8000. If this is the case, the LSb (bit 16 of the accumulator) of ACCxH is examined. If it is '1', ACCxH is incremented. If it is '0', ACCxH is not modified. Assuming that bit 16 is effectively random in nature, this scheme will remove any rounding bias that may accumulate.

The SAC and SAC.R instructions store either a truncated (SAC) or rounded (SAC.R) version of the contents of the target accumulator to data memory, via the X bus (subject to data saturation, see [Section 2.4.2.4 "Data Space Write Saturation"](#)). Note that for the MAC class of instructions, the accumulator write back operation will function in the same manner, addressing combined MCU (X and Y) data space though the X bus. For this class of instructions, the data is always subject to rounding.

2.4.2.4 Data Space Write Saturation

In addition to adder/subtractor saturation, writes to data space may also be saturated, but without affecting the contents of the source accumulator. The data space write saturation logic block accepts a 16-bit, 1.15 fractional value from the round logic block as its input, together with overflow status from the original source (accumulator) and the 16-bit round adder. These are combined and used to select the appropriate 1.15 fractional value as output to write to data space memory.

If the SATDW bit in the CORCON register is set, data (after rounding or truncation) is tested for overflow and adjusted accordingly. For input data greater than 0x007FFF, data written to memory is forced to the maximum positive 1.15 value, 0x7FFF. For input data less than 0xFF8000, data written to memory is forced to the maximum negative 1.15 value, 0x8000. The MSb of the source (bit 39) is used to determine the sign of the operand being tested.

If the SATDW bit in the CORCON register is not set, the input data is always passed through unmodified under all conditions.

2.4.3 BARREL SHIFTER

The barrel shifter is capable of performing up to 16-bit arithmetic or logic right shifts, or up to 16-bit left shifts in a single cycle. The source can be either of the two DSP accumulators or the X bus (to support multi-bit shifts of register or memory data).

The shifter requires a signed binary value to determine both the magnitude (number of bits) and direction of the shift operation. A positive value will shift the operand right. A negative value will shift the operand left. A value of '0' will not modify the operand.

The barrel shifter is 40 bits wide, thereby obtaining a 40-bit result for DSP shift operations and a 16-bit result for MCU shift operations. Data from the X bus is presented to the barrel shifter between bit positions 16 to 31 for right shifts, and bit positions 0 to 15 for left shifts.

3.0 MEMORY ORGANIZATION

Note: This data sheet summarizes features of this group of dsPIC30F devices and is not intended to be a complete reference source. For more information on the CPU, peripherals, register descriptions and general device functionality, refer to the “dsPIC30F Family Reference Manual” (DS70046). For more information on the device instruction set and programming, refer to the “16-bit MCU and DSC Programmer’s Reference Manual” (DS70157).

3.1 Program Address Space

The program address space is 4M instruction words. It is addressable by the 23-bit PC, table instruction Effective Address (EA), or data space EA, when program space is mapped into data space, as defined by Table 3-1. Note that the program space address is incremented by two between successive program words, in order to provide compatibility with data space addressing.

User program space access is restricted to the lower 4M instruction word address range (0x000000 to 0x7FFFFE), for all accesses other than TBLRD/TBLWT, which use TBLPAG<7> to determine user or configuration space access. In TABLE 3-1: “Program Space Address Construction”, bit 23 allows access to the Device ID, the User ID and the Configuration bits. Otherwise, bit 23 is always clear.

FIGURE 3-1: PROGRAM SPACE MEMORY MAP FOR dsPIC30F5015/5016

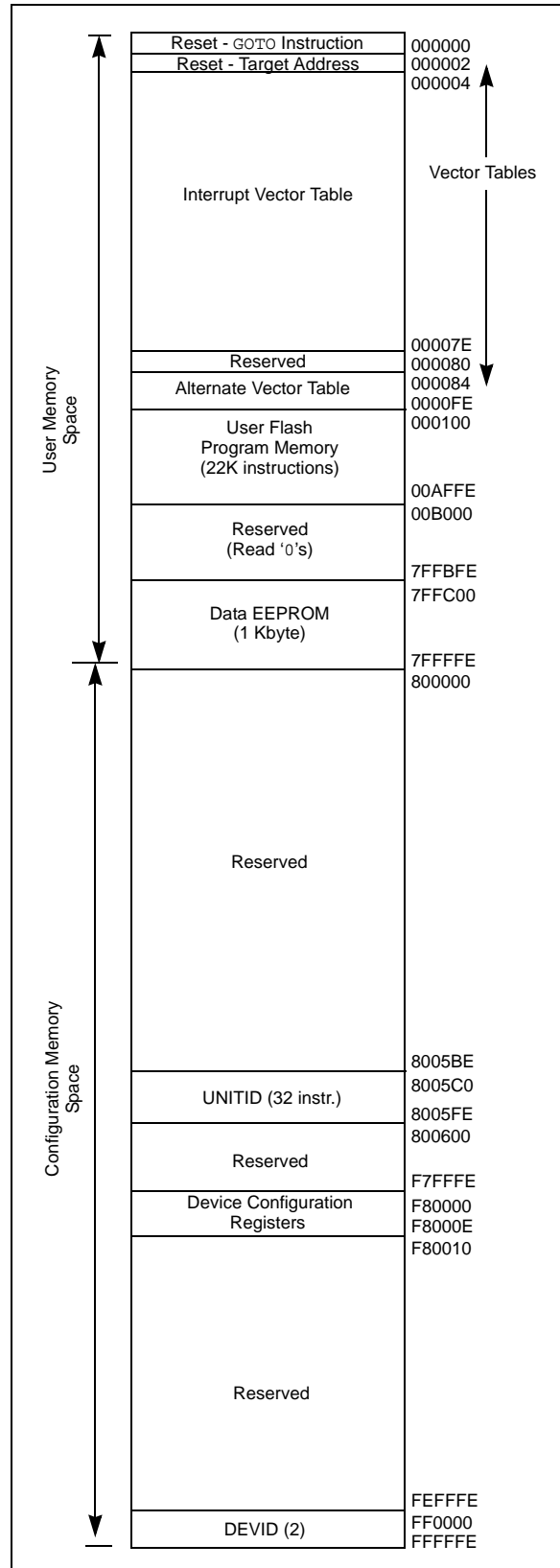

dsPIC30F5015/5016

TABLE 3-1: PROGRAM SPACE ADDRESS CONSTRUCTION

Access Type	Access Space	Program Space Address				
		<23>	<22:16>	<15>	<14:1>	<0>
Instruction Access	User	0	PC<22:1>			0
TBLRD/TBLWT	User (TBLPAG<7> = 0)	TBLPAG<7:0>		Data EA<15:0>		
TBLRD/TBLWT	Configuration (TBLPAG<7> = 1)	TBLPAG<7:0>		Data EA<15:0>		
Program Space Visibility	User	0	PSVPAG<7:0>	Data EA<14:0>		

FIGURE 3-2: DATA ACCESS FROM PROGRAM SPACE ADDRESS GENERATION

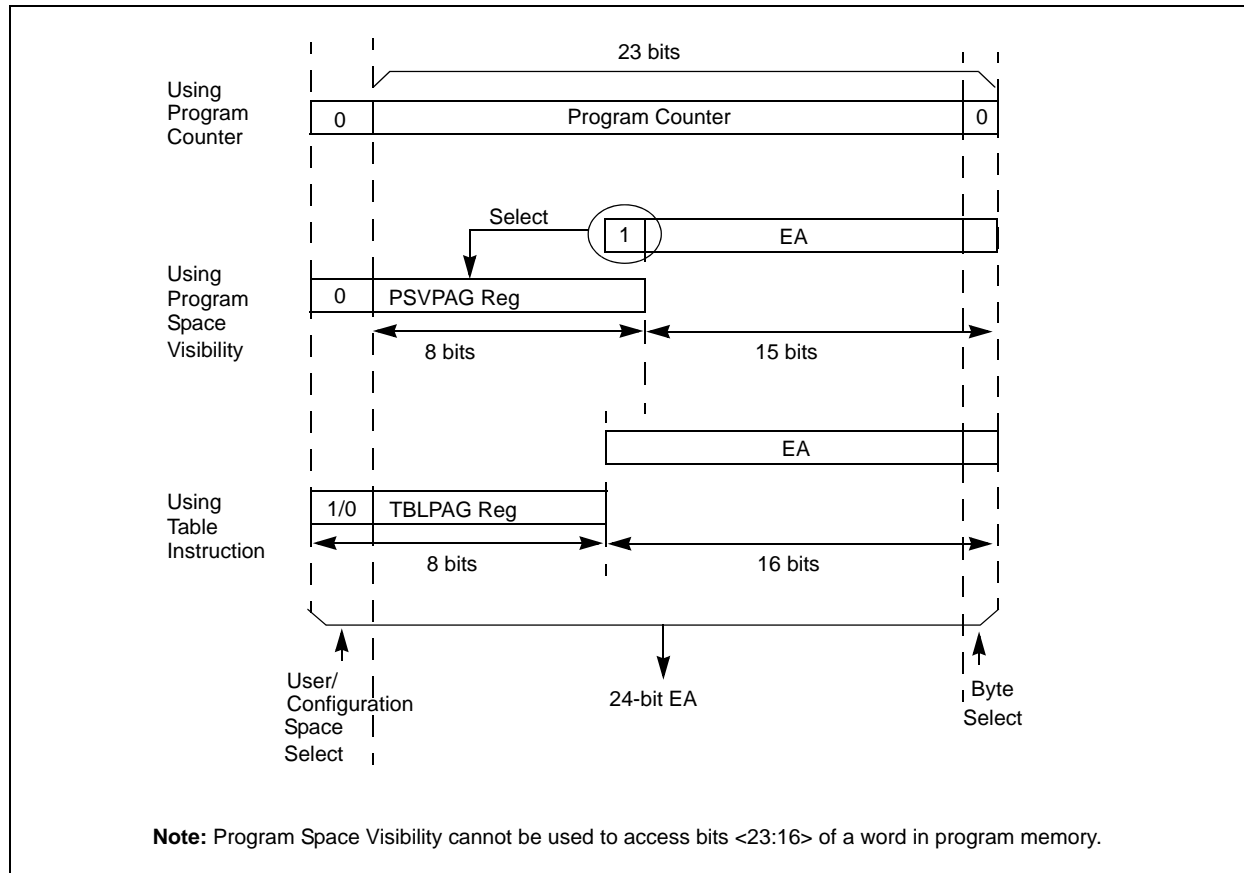

3.1.1 DATA ACCESS FROM PROGRAM MEMORY USING TABLE INSTRUCTIONS

This architecture fetches 24-bit wide program memory. Consequently, instructions are always aligned. However, as the architecture is modified Harvard, data can also be present in program space.

There are two methods by which program space can be accessed; via special table instructions, or through the remapping of a 16K word program space page into the upper half of data space (see [Section 3.1.2 “Data Access from Program Memory Using Program Space Visibility”](#)). The **TBLRDL** and **TBLWTL** instructions offer a direct method of reading or writing the least significant word of any address within program space, without going through data space. The **TBLRDH** and **TBLWTH** instructions are the only method whereby the upper 8 bits of a program space word can be accessed as data.

The PC is incremented by two for each successive 24-bit program word. This allows program memory addresses to directly map to data space addresses. Program memory can thus be regarded as two 16-bit word wide address spaces, residing side by side, each with the same address range. **TBLRDL** and **TBLWTL** access the space that contains the least significant word, and **TBLRDH** and **TBLWTH** access the space that contains the MSB.

[Figure 3-2](#) shows how the EA is created for table operations and data space accesses (PSV = 1). Here, P<23:0> refers to a program space word, whereas D<15:0> refers to a data space word.

A set of table instructions are provided to move byte or word-sized data to and from program space.

1. **TBLRDL**: Table Read Low
Word: Read the least significant word of the program address;
P<15:0> maps to D<15:0>.
Byte: Read one of the LSBs of the program address;
P<7:0> maps to the destination byte when byte select = 0;
P<15:8> maps to the destination byte when byte select = 1.
2. **TBLWTL**: Table Write Low (refer to [Section 6.0 “Flash Program Memory”](#) for details on Flash Programming).
3. **TBLRDH**: Table Read High
Word: Read the most significant word of the program address;
P<23:16> maps to D<7:0>; D<15:8> always is = 0.
Byte: Read one of the MSBs of the program address;
P<23:16> maps to the destination byte when byte select = 0;
The destination byte will always be = 0 when byte select = 1.
4. **TBLWTH**: Table Write High (refer to [Section 6.0 “Flash Program Memory”](#) for details on Flash Programming).

FIGURE 3-3: PROGRAM DATA TABLE ACCESS (LEAST SIGNIFICANT WORD)

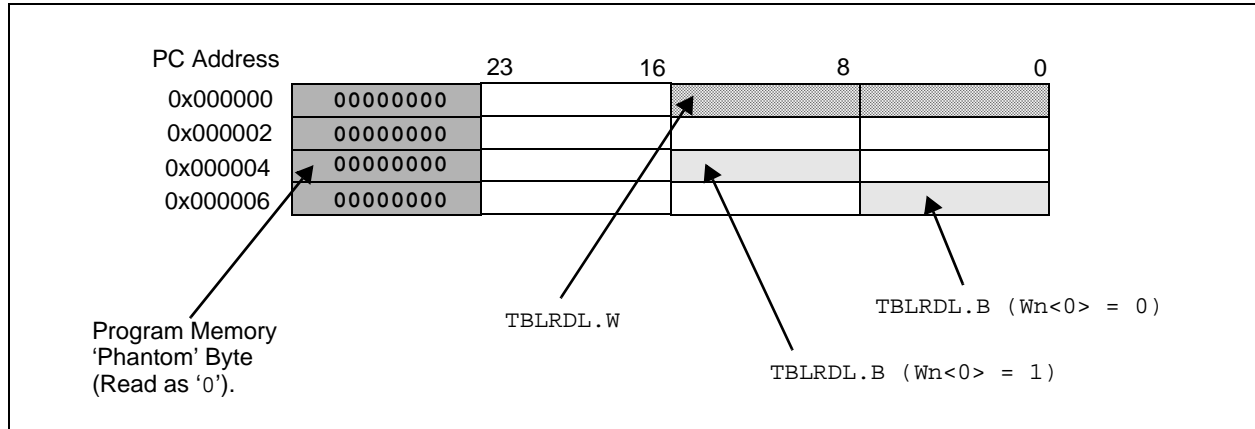

dsPIC30F5015/5016

FIGURE 3-4: PROGRAM DATA TABLE ACCESS (MSB)

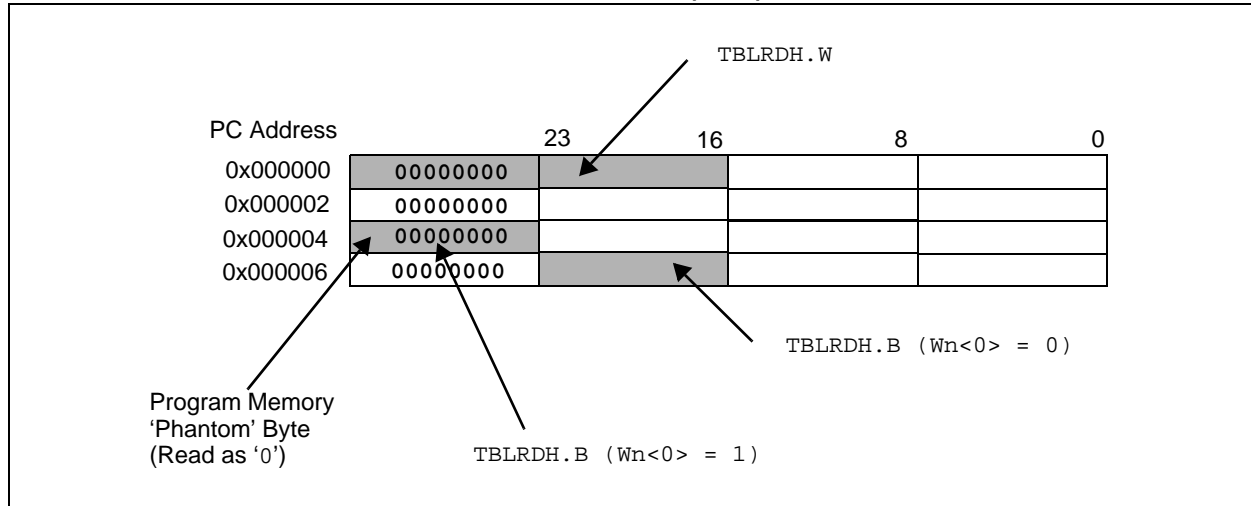

3.1.2 DATA ACCESS FROM PROGRAM MEMORY USING PROGRAM SPACE VISIBILITY

The upper 32 Kbytes of data space may optionally be mapped into any 16K word program space page. This provides transparent access of stored constant data from X data space, without the need to use special instructions (i.e., TBLRDL/H, TBLWTL/H instructions).

Program space access through the data space occurs if the MSb of the data space EA is set and program space visibility is enabled, by setting the PSV bit in the Core Control register (CORCON). The functions of CORCON are discussed in [Section 2.4 "DSP Engine"](#).

Data accesses to this area add an additional cycle to the instruction being executed, since two program memory fetches are required.

Note that the upper half of addressable data space is always part of the X data space. Therefore, when a DSP operation uses program space mapping to access this memory region, Y data space should typically contain state (variable) data for DSP operations, whereas X data space should typically contain coefficient (constant) data.

Although each data space address, 0x8000 and higher, maps directly into a corresponding program memory address (see Figure 3-5), only the lower 16 bits of the 24-bit program word are used to contain the data. The upper 8 bits should be programmed to force an illegal instruction to maintain machine robustness. Refer to the *"16-bit MCU and DSC Programmer's Reference Manual"* (DS70157) for details on instruction encoding.

Note that by incrementing the PC by 2 for each program memory word, the Least Significant 15 bits of data space addresses directly map to the Least Significant 15 bits in the corresponding program space addresses. The remaining bits are provided by the Program Space Visibility Page register, PSVPAG<7:0>, as shown in [Figure 3-5](#).

Note: PSV access is temporarily disabled during table reads/writes.

For instructions which use PSV that are executed outside a REPEAT loop:

- The following instructions will require one instruction cycle in addition to the specified execution time:
 - MAC class of instructions with data operand prefetch
 - MOV instructions
 - MOV.D instructions
- All other instructions will require two instruction cycles in addition to the specified execution time of the instruction.

For instructions that use PSV which are executed inside a REPEAT loop:

- The following instances will require two instruction cycles in addition to the specified execution time of the instruction:
 - Execution in the first iteration
 - Execution in the last iteration
 - Execution prior to exiting the loop due to an interrupt
 - Execution upon re-entering the loop after an interrupt is serviced
- Any other iteration of the REPEAT loop will allow the instruction, accessing data using PSV, to execute in a single cycle.

FIGURE 3-5: DATA SPACE WINDOW INTO PROGRAM SPACE OPERATION

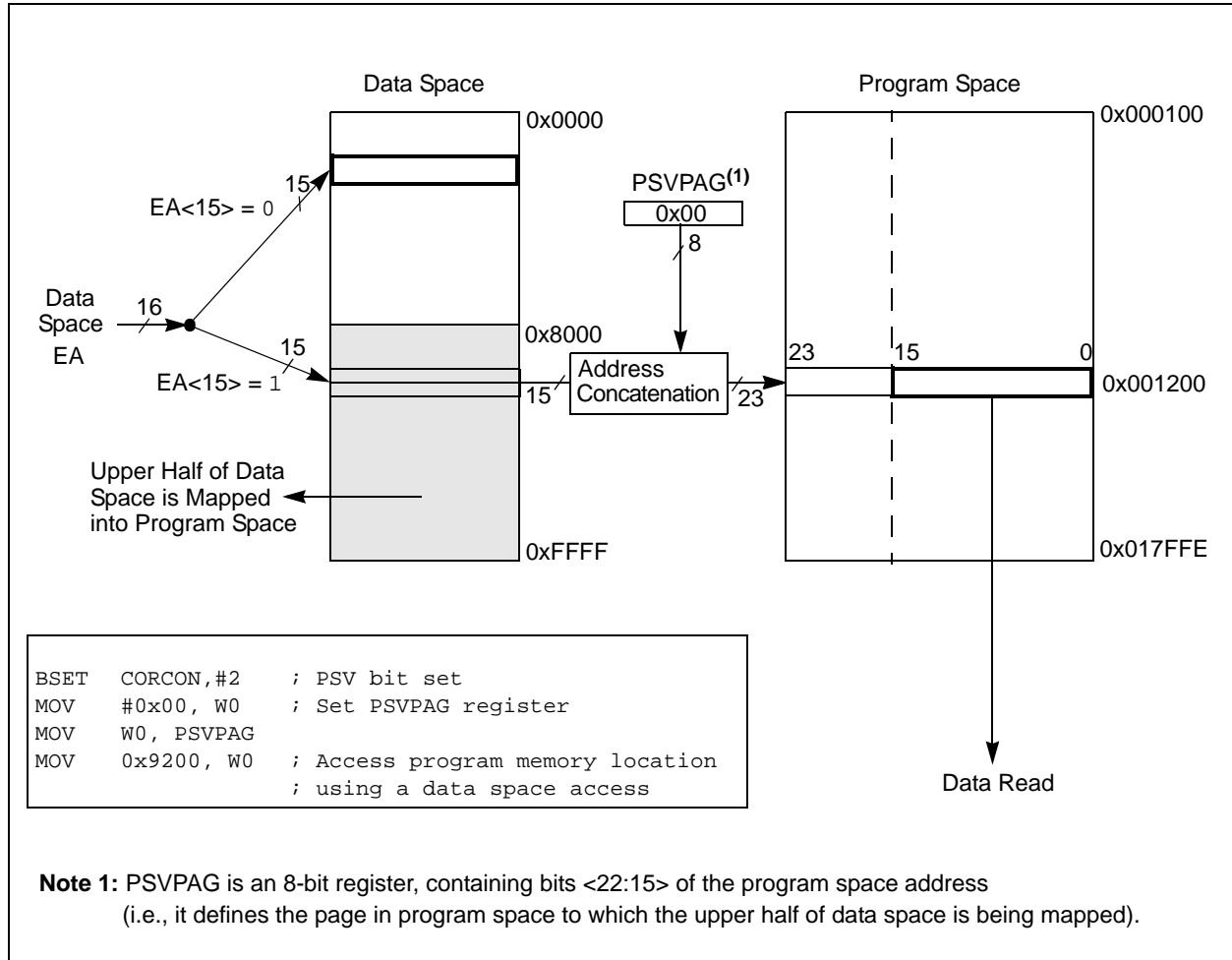

3.2 Data Address Space

The core has two data spaces. The data spaces can be considered either separate (for some DSP instructions), or as one unified linear address range (for MCU instructions). The data spaces are accessed using two Address Generation Units (AGUs) and separate data paths.

3.2.1 DATA SPACE MEMORY MAP

The data space memory is split into two blocks, X and Y data space. A key element of this architecture is that Y space is a subset of X space, and is fully contained within X space. In order to provide an apparent linear addressing space, X and Y spaces have contiguous addresses.

When executing any instruction other than one of the MAC class of instructions, the X block consists of the 64 Kbyte data address space (including all Y addresses). When executing one of the MAC class of instructions, the X block consists of the 64 Kbyte data address space excluding the Y address block (for data reads only). In other words, all other instructions regard the entire data memory as one composite address space. The MAC class instructions extract the Y address space from data space and address it using EAs sourced from W10 and W11. The remaining X data space is addressed using W8 and W9. Both address spaces are concurrently accessed only with the MAC class instructions.

A data space memory map is shown in [Figure 3-6](#).

[Figure 3-7](#) shows a graphical summary of how X and Y data spaces are accessed for MCU and DSP instructions.

dsPIC30F5015/5016

FIGURE 3-6: dsPIC30F5015/5016 DATA SPACE MEMORY MAP

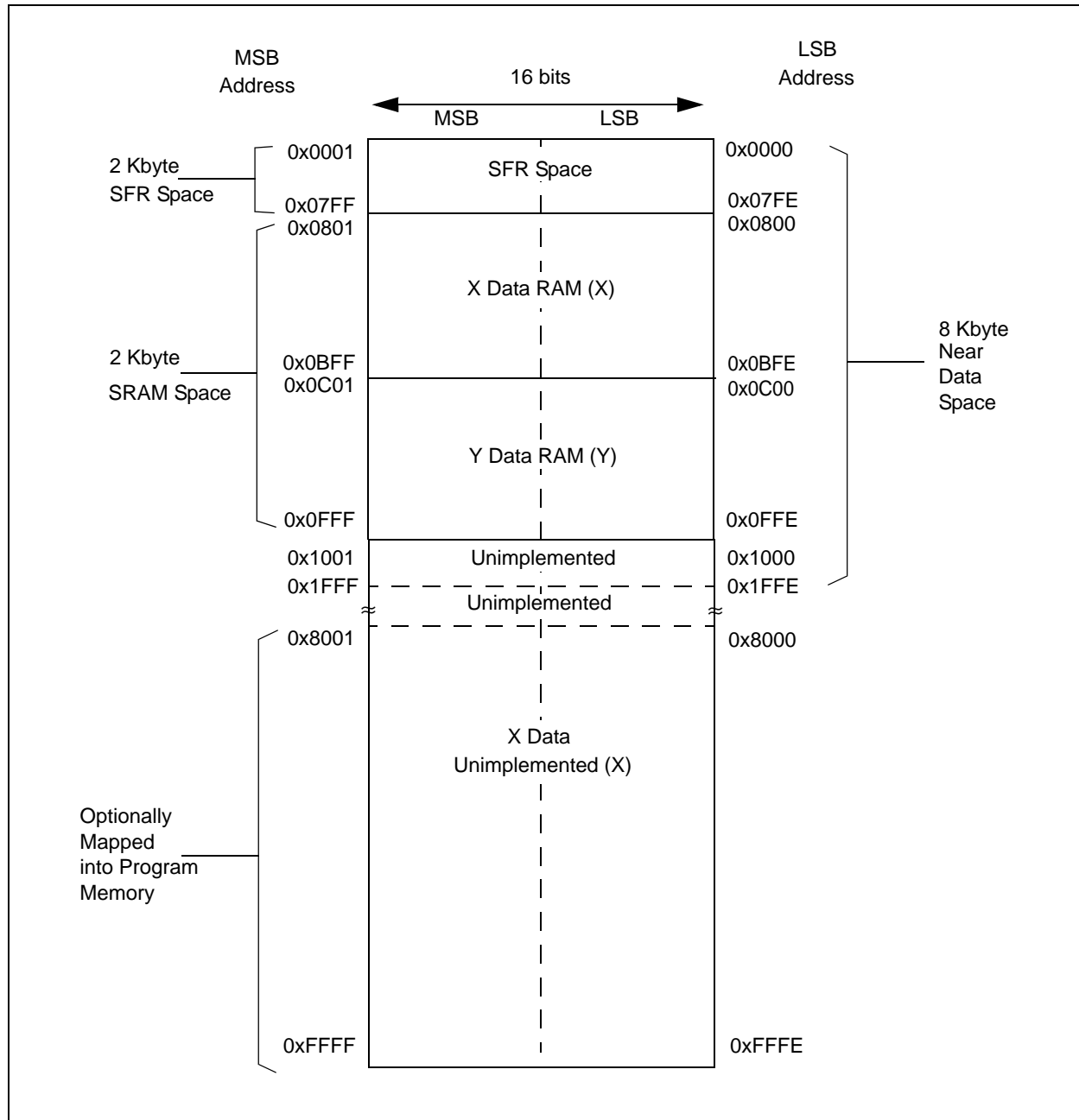
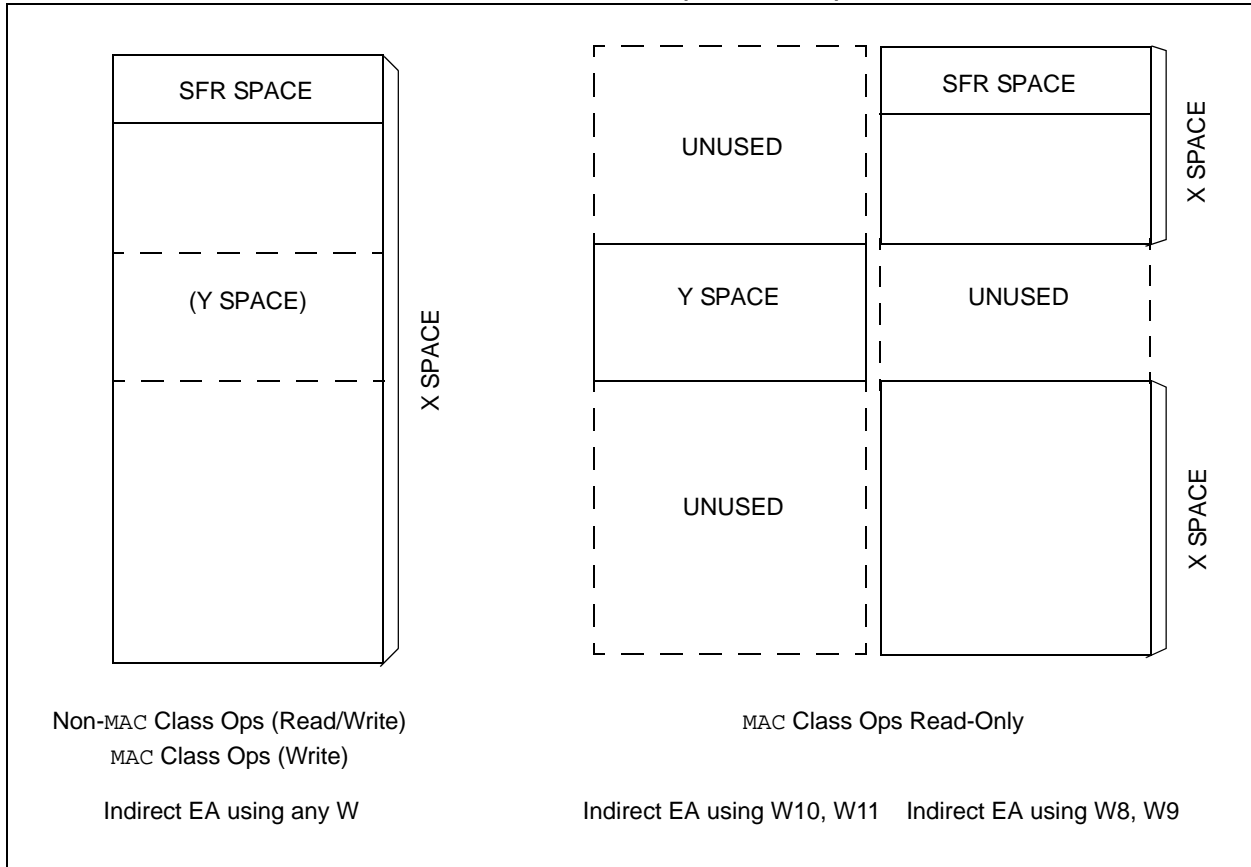

FIGURE 3-7: DATA SPACE FOR MCU AND DSP (MAC CLASS) INSTRUCTIONS EXAMPLE



dsPIC30F5015/5016

3.2.2 DATA SPACES

The X data space is used by all instructions and supports all addressing modes. There are separate read and write data buses. The X read data bus is the return data path for all instructions that view data space as combined X and Y address space. It is also the X address space data path for the dual operand read instructions (MAC class). The X write data bus is the only write path to data space for all instructions.

The X data space also supports Modulo Addressing for all instructions, subject to addressing mode restrictions. Bit-Reversed Addressing is only supported for writes to X data space.

The Y data space is used in concert with the X data space by the MAC class of instructions (CLR, ED, EDAC, MAC, MOVSAC, MPY, MPY.N and MSC) to provide two concurrent data read paths. No writes occur across the Y bus. This class of instructions dedicates two W register pointers, W10 and W11, to always address Y data space, independent of X data space, whereas W8 and W9 always address X data space. Note that during accumulator write back, the data address space is considered a combination of X and Y data spaces, so the write occurs across the X bus. Consequently, the write can be to any address in the entire data space.

The Y data space can only be used for the data prefetch operation associated with the MAC class of instructions. It also supports Modulo Addressing for automated circular buffers. Of course, all other instructions can access the Y data address space through the X data path, as part of the composite linear space.

The boundary between the X and Y data spaces is defined as shown in Figure 3-6 and is not user programmable. Should an EA point to data outside its own assigned address space, or to a location outside physical memory, an all-zero word/byte will be returned. For example, although Y address space is visible by all non-MAC instructions using any addressing mode, an attempt by a MAC instruction to fetch data from that space, using W8 or W9 (X space pointers), will return 0x0000.

TABLE 3-2: EFFECT OF INVALID MEMORY ACCESSES

Attempted Operation	Data Returned
EA = an unimplemented address	0x0000
W8 or W9 used to access Y data space in a MAC instruction	0x0000
W10 or W11 used to access X data space in a MAC instruction	0x0000

All effective addresses are 16 bits wide and point to bytes within the data space. Therefore, the data space address range is 64 Kbytes or 32K words.

3.2.3 DATA SPACE WIDTH

The core data width is 16 bits. All internal registers are organized as 16-bit wide words. Data space memory is organized in byte addressable, 16-bit wide blocks.

3.2.4 DATA ALIGNMENT

To help maintain backward compatibility with PIC® devices and improve data space memory usage efficiency, the dsPIC30F instruction set supports both word and byte operations. Data is aligned in data memory and registers as words, but all data space EAs resolve to bytes. Data byte reads will read the complete word, which contains the byte, using the LSB of any EA to determine which byte to select. The selected byte is placed onto the LSB of the X data path (no byte accesses are possible from the Y data path as the MAC class of instruction can only fetch words). That is, data memory and registers are organized as two parallel byte wide entities with shared (word) address decode, but separate write lines. Data byte writes only write to the corresponding side of the array or register which matches the byte address.

As a consequence of this byte accessibility, all effective address calculations (including those generated by the DSP operations, which are restricted to word-sized data) are internally scaled to step through word-aligned memory. For example, the core would recognize that Post-Modified Register Indirect Addressing mode, [Ws++], will result in a value of Ws + 1 for byte operations and Ws + 2 for word operations.

All word accesses must be aligned to an even address. Misaligned word data fetches are not supported, so care must be taken when mixing byte and word operations, or translating from 8-bit MCU code. Should a misaligned read or write be attempted, an address error trap will be generated. If the error occurred on a read, the instruction underway is completed, whereas if it occurred on a write, the instruction will be executed but the write will not occur. In either case, a trap will then be executed, allowing the system and/or user to examine the machine state prior to execution of the address fault.

FIGURE 3-8: DATA ALIGNMENT

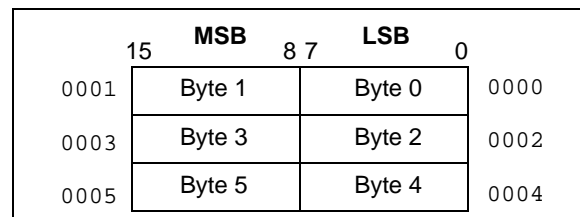

All byte loads into any W register are loaded into the LSB. The MSB is not modified.

A sign-extend (SE) instruction is provided to allow users to translate 8-bit signed data to 16-bit signed values. Alternatively, for 16-bit unsigned data, users can clear the MSB of any W register by executing a zero-extend (ZE) instruction on the appropriate address.

Although most instructions are capable of operating on word or byte data sizes, it should be noted that some instructions, including the DSP instructions, operate only on words.

3.2.5 NEAR DATA SPACE

An 8 Kbyte 'near' data space is reserved in X address memory space between 0x0000 and 0x1FFF, which is directly addressable via a 13-bit absolute address field within all memory direct instructions. The remaining X address space and all of the Y address space is addressable indirectly. Additionally, the whole of X data space is addressable using MOV instructions, which support memory direct addressing with a 16-bit address field.

3.2.6 SOFTWARE STACK

The dsPIC DSC device contains a software stack. W15 is used as the Stack Pointer.

The Stack Pointer always points to the first available free word and grows from lower addresses towards higher addresses. It pre-decrements for stack pops and post-increments for stack pushes, as shown in Figure 3-9. Note that for a PC push during any CALL instruction, the MSB of the PC is zero-extended before the push, ensuring that the MSB is always clear.

Note: A PC push during exception processing will concatenate the SRL register to the MSB of the PC prior to the push.

There is a Stack Pointer Limit register (SPLIM) associated with the Stack Pointer. SPLIM is uninitialized at Reset. As is the case for the Stack Pointer, $SPLIM<0>$ is forced to '0', because all stack operations must be word-aligned. Whenever an Effective Address (EA) is generated using W15 as a source or destination pointer, the address thus generated is compared with the value in SPLIM. If the contents of the Stack Pointer (W15) and the SPLIM register are equal and a push operation is performed, a stack error trap will not occur. The stack error trap will occur on a subsequent push operation. Thus, for example, if it is desirable to cause a stack error trap when the stack grows beyond address 0x2000 in RAM, initialize the SPLIM with the value, 0x1FFE.

Similarly, a Stack Pointer underflow (stack error) trap is generated when the Stack Pointer address is found to be less than 0x0800, thus preventing the stack from interfering with the Special Function Register (SFR) space.

A write to the SPLIM register should not be immediately followed by an indirect read operation using W15.

FIGURE 3-9: CALL STACK FRAME

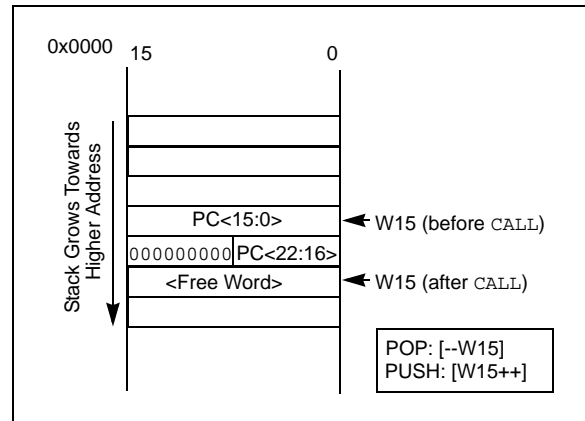

TABLE 3-3: CORE REGISTER MAP⁽¹⁾

SFR Name	Address (Home)	Bit 15	Bit 14	Bit 13	Bit 12	Bit 11	Bit 10	Bit 9	Bit 8	Bit 7	Bit 6	Bit 5	Bit 4	Bit 3	Bit 2	Bit 1	Bit 0	Reset State	
W0	0000	W0/WREG																0000 0000 0000 0000	
W1	0002	W1																0000 0000 0000 0000	
W2	0004	W2																0000 0000 0000 0000	
W3	0006	W3																0000 0000 0000 0000	
W4	0008	W4																0000 0000 0000 0000	
W5	000A	W5																0000 0000 0000 0000	
W6	000C	W6																0000 0000 0000 0000	
W7	000E	W7																0000 0000 0000 0000	
W8	0010	W8																0000 0000 0000 0000	
W9	0012	W9																0000 0000 0000 0000	
W10	0014	W10																0000 0000 0000 0000	
W11	0016	W11																0000 0000 0000 0000	
W12	0018	W12																0000 0000 0000 0000	
W13	001A	W13																0000 0000 0000 0000	
W14	001C	W14																0000 0000 0000 0000	
W15	001E	W15																0000 1000 0000 0000	
SPLIM	0020	SPLIM																0000 0000 0000 0000	
ACCAL	0022	ACCAL																0000 0000 0000 0000	
ACCAH	0024	ACCAH																0000 0000 0000 0000	
ACCAU	0026	Sign-Extension (ACCA<39>)								ACCAU								0000 0000 0000 0000	
ACCBL	0028	ACCBL																0000 0000 0000 0000	
ACCBH	002A	ACCBH																0000 0000 0000 0000	
ACCBU	002C	Sign-Extension (ACCB<39>)								ACCBU								0000 0000 0000 0000	
PCL	002E	PCL																0000 0000 0000 0000	
PCH	0030	—	—	—	—	—	—	—	—	—	PCH							0000 0000 0000 0000	
TBLPAG	0032	—	—	—	—	—	—	—	—	TBLPAG								0000 0000 0000 0000	
PSVPAG	0034	—	—	—	—	—	—	—	—	PSVPAG								0000 0000 0000 0000	
RCOUNT	0036	RCOUNT																uuuu uuuu uuuu uuuu	
DCOUNT	0038	DCOUNT																uuuu uuuu uuuu uuuu	
DOSTARTL	003A	DOSTARTL																0	uuuu uuuu uuuu uu0
DOSTARTH	003C	—	—	—	—	—	—	—	—	—	DOSTARTH							0000 0000 0uuu uuuu	
DOENDL	003E	DOENDL																0	uuuu uuuu uuuu uu0
DOENDH	0040	—	—	—	—	—	—	—	—	DOENDH								0000 0000 0uuu uuuu	
SR	0042	OA	OB	SA	SB	OAB	SAB	DA	DC	IPL2	IPL1	IPL0	RA	N	OV	Z	C	0000 0000 0000 0000	
CORCON	0044	—	—	—	US	EDT	DL2	DL1	DL0	SATA	SATB	SATDW	ACCSAT	IPL3	PSV	RND	IF	0000 0000 0010 0000	

Legend: u = uninitialized bit; — = unimplemented bit, read as '0'

Note 1: Refer to the "dsPIC30F Family Reference Manual" (DS70046) for descriptions of register bit fields.

TABLE 3-3: CORE REGISTER MAP⁽¹⁾ (CONTINUED)

SFR Name	Address (Home)	Bit 15	Bit 14	Bit 13	Bit 12	Bit 11	Bit 10	Bit 9	Bit 8	Bit 7	Bit 6	Bit 5	Bit 4	Bit 3	Bit 2	Bit 1	Bit 0	Reset State
MODCON	0046	XMODEN	YMODEN	—	—	BWM<3:0>			YWM<3:0>			XWM<3:0>			0000 0000 0000 0000			
XMODSRT	0048	XS<15:1>															0	uuuu uuuu uuuu uuu0
XMODEND	004A	XE<15:1>															1	uuuu uuuu uuuu uuu1
YMODSRT	004C	YS<15:1>															0	uuuu uuuu uuuu uuu0
YMODEND	004E	YE<15:1>															1	uuuu uuuu uuuu uuu1
XBREV	0050	BREN	XB<14:0>															uuuu uuuu uuuu uuuu
DISICNT	0052	—	—	DISICNT<13:0>													0000 0000 0000 0000	

Legend: u = uninitialized bit; — = unimplemented bit, read as '0'

Note 1: Refer to the “dsPIC30F Family Reference Manual” (DS70046) for descriptions of register bit fields.

dsPIC30F5015/5016

NOTES:

4.0 ADDRESS GENERATOR UNITS

Note: This data sheet summarizes features of this group of dsPIC30F devices and is not intended to be a complete reference source. For more information on the CPU, peripherals, register descriptions and general device functionality, refer to the “dsPIC30F Family Reference Manual” (DS70046). For more information on the device instruction set and programming, refer to the “16-bit MCU and DSC Programmer’s Reference Manual” (DS70157).

The dsPIC DSC core contains two independent Address Generator Units (AGUs): the X AGU and Y AGU. The Y AGU supports word-sized data reads for the DSP MAC class of instructions only. The dsPIC DSC AGUs support three types of data addressing:

- Linear Addressing
- Modulo (Circular) Addressing
- Bit-Reversed Addressing

Linear and Modulo Data Addressing modes can be applied to data space or program space. Bit-Reversed Addressing is only applicable to data space addresses.

4.1 Instruction Addressing Modes

The addressing modes in [Table 4-1](#) form the basis of the addressing modes optimized to support the specific features of individual instructions. The addressing modes provided in the MAC class of instructions are somewhat different from those in the other instruction types.

4.1.1 FILE REGISTER INSTRUCTIONS

Most file register instructions use a 13-bit address field (f) to directly address data present in the first 8192 bytes of data memory (near data space). Most file register instructions employ a working register W0, which is denoted as WREG in these instructions. The destination is typically either the same file register, or WREG (with the exception of the MUL instruction), which writes the result to a register or register pair. The MOV instruction allows additional flexibility and can access the entire data space during file register operation.

4.1.2 MCU INSTRUCTIONS

The three-operand MCU instructions are of the form:

Operand 3 = Operand 1 <function> Operand 2

where Operand 1 is always a working register (i.e., the addressing mode can only be Register Direct), which is referred to as Wb. Operand 2 can be a W register, fetched from data memory, or a 5-bit literal. The result location can be either a W register or an address location. The following addressing modes are supported by MCU instructions:

- Register Direct
- Register Indirect
- Register Indirect Post-Modified
- Register Indirect Pre-Modified
- 5-bit or 10-bit Literal

Note: Not all instructions support all the addressing modes given above. Individual instructions may support different subsets of these addressing modes.

TABLE 4-1: FUNDAMENTAL ADDRESSING MODES SUPPORTED

Addressing Mode	Description
File Register Direct	The address of the file register is specified explicitly.
Register Direct	The contents of a register are accessed directly.
Register Indirect	The contents of Wn forms the EA.
Register Indirect Post-Modified	The contents of Wn forms the EA. Wn is post-modified (incremented or decremented) by a constant value.
Register Indirect Pre-Modified	Wn is pre-modified (incremented or decremented) by a signed constant value to form the EA.
Register Indirect with Register Offset	The sum of Wn and Wb forms the EA.
Register Indirect with Literal Offset	The sum of Wn and a literal forms the EA.

dsPIC30F5015/5016

4.1.3 MOVE AND ACCUMULATOR INSTRUCTIONS

Move instructions and the DSP Accumulator class of instructions provide a greater degree of addressing flexibility than other instructions. In addition to the addressing modes supported by most MCU instructions, Move and Accumulator instructions also support Register Indirect with Register Offset Addressing mode, also referred to as Register Indexed mode.

Note: For the `MOV` instructions, the addressing mode specified in the instruction can differ for the source and destination EA. However, the 4-bit `Wb` (Register Offset) field is shared between both source and destination (but typically only used by one).

In summary, the following addressing modes are supported by Move and Accumulator instructions:

- Register Direct
- Register Indirect
- Register Indirect Post-Modified
- Register Indirect Pre-Modified
- Register Indirect with Register Offset (Indexed)
- Register Indirect with Literal Offset
- 8-bit Literal
- 16-bit Literal

Note: Not all instructions support all the addressing modes given above. Individual instructions may support different subsets of these addressing modes.

4.1.4 MAC INSTRUCTIONS

The dual source operand DSP instructions (`CLR`, `ED`, `EDAC`, `MAC`, `MPY`, `MPY.N`, `MOVSAC` and `MSC`), also referred to as `MAC` instructions, utilize a simplified set of addressing modes to allow the user to effectively manipulate the data pointers through Register Indirect tables.

The two source operand prefetch registers must be a member of the set {`W8`, `W9`, `W10`, `W11`}. For data reads, `W8` and `W9` will always be directed to the X RAGU and `W10` and `W11` will always be directed to the Y AGU. The effective addresses generated (before and after modification) must, therefore, be valid addresses within X data space for `W8` and `W9` and Y data space for `W10` and `W11`.

Note: Register Indirect with Register Offset Addressing is only available for `W9` (in X space) and `W11` (in Y space).

In summary, the following addressing modes are supported by the `MAC` class of instructions:

- Register Indirect
- Register Indirect Post-Modified by 2
- Register Indirect Post-Modified by 4
- Register Indirect Post-Modified by 6
- Register Indirect with Register Offset (Indexed)

4.1.5 OTHER INSTRUCTIONS

Besides the various addressing modes outlined above, some instructions use literal constants of various sizes. For example, `BRA` (branch) instructions use 16-bit signed literals to specify the branch destination directly, whereas the `DISI` instruction uses a 14-bit unsigned literal field. In some instructions, such as `ADD ACC`, the source of an operand or result is implied by the opcode itself. Certain operations, such as `NOP`, do not have any operands.

4.2 Modulo Addressing

Modulo Addressing is a method of providing an automated means to support circular data buffers using hardware. The objective is to remove the need for software to perform data address boundary checks when executing tightly looped code, as is typical in many DSP algorithms.

Modulo Addressing can operate in either data or program space (since the data pointer mechanism is essentially the same for both). One circular buffer can be supported in each of the X (which also provides the pointers into program space) and Y data spaces. Modulo Addressing can operate on any `W` register pointer. However, it is not advisable to use `W14` or `W15` for Modulo Addressing, since these two registers are used as the Stack Frame Pointer and Stack Pointer, respectively.

In general, any particular circular buffer can only be configured to operate in one direction, as there are certain restrictions on the buffer start address (for incrementing buffers) or end address (for decrementing buffers) based upon the direction of the buffer.

The only exception to the usage restrictions is for buffers which have a power-of-2 length. As these buffers satisfy the start and end address criteria, they may operate in a Bidirectional mode, (i.e., address boundary checks will be performed on both the lower and upper address boundaries).

4.2.1 START AND END ADDRESS

The Modulo Addressing scheme requires that a starting and an ending address be specified and loaded into the 16-bit Modulo Buffer Address registers: XMODSRT, XMODEND, YMODSRT and YMODEND (see Table 3-3).

Note: Y-space Modulo Addressing EA calculations assume word-sized data (LSb of every EA is always clear).

The length of a circular buffer is not directly specified. It is determined by the difference between the corresponding start and end addresses. The maximum possible length of the circular buffer is 32K words (64 Kbytes).

4.2.2 W ADDRESS REGISTER SELECTION

The Modulo and Bit-Reversed Addressing Control register, MODCON<15:0>, contains enable flags, as well as a W register field to specify the W Address registers. The XWM and YWM fields select which registers will operate with Modulo Addressing. If XWM = 15, X RAGU and X WAGU Modulo Addressing are disabled. Similarly, if YWM = 15, Y AGU Modulo Addressing is disabled.

The X Address Space Pointer W register (XWM) to which Modulo Addressing is to be applied, is stored in MODCON<3:0> (see Table 3-3). Modulo Addressing is enabled for X data space when XWM is set to any value other than 15 and the XMODEN bit is set at MODCON<15>.

The Y Address Space Pointer W register (YWM) to which Modulo Addressing is to be applied, is stored in MODCON<7:4>. Modulo Addressing is enabled for Y data space when YWM is set to any value other than 15 and the YMODEN bit is set at MODCON<14>.

FIGURE 4-1: MODULO ADDRESSING OPERATION EXAMPLE

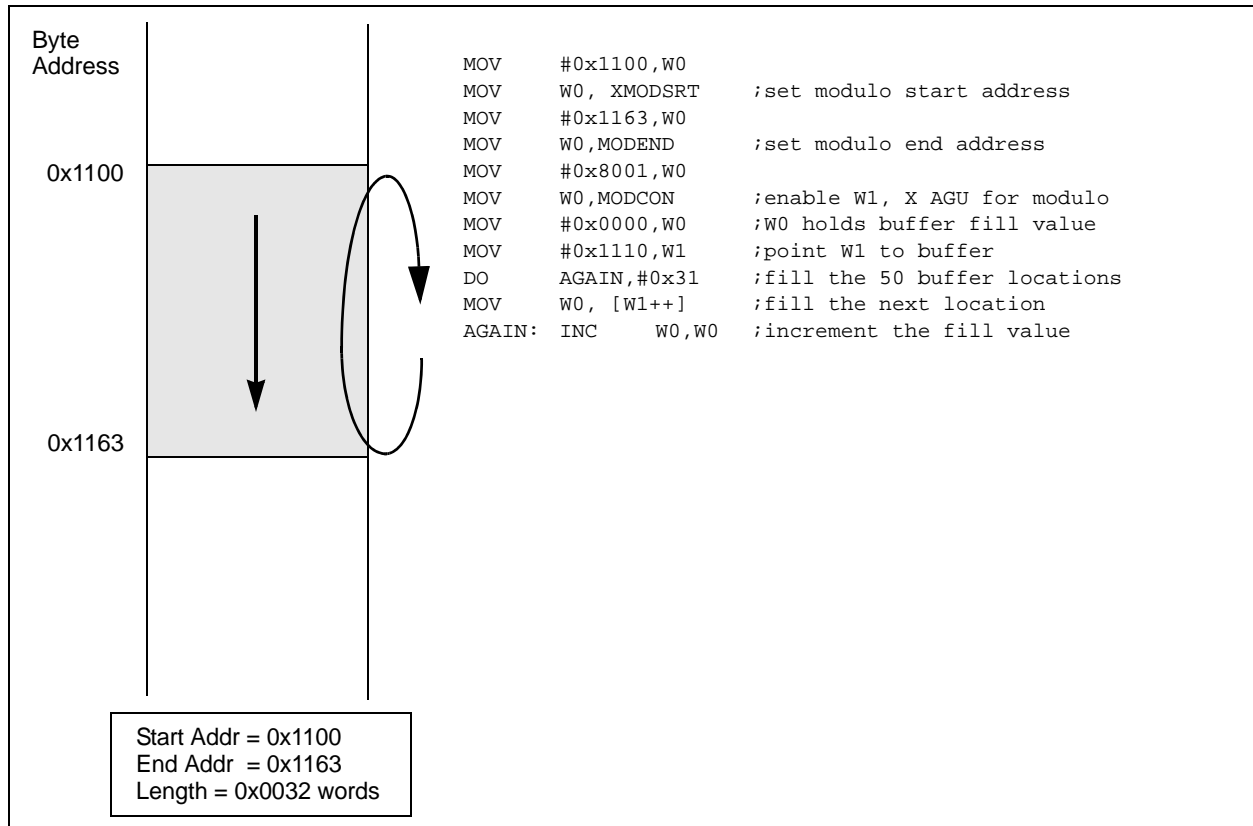

dsPIC30F5015/5016

4.2.3 MODULO ADDRESSING APPLICABILITY

Modulo Addressing can be applied to the Effective Address (EA) calculation associated with any W register. It is important to realize that the address boundaries check for addresses less than or greater than the upper (for incrementing buffers) and lower (for decrementing buffers) boundary addresses (not just equal to). Address changes may, therefore, jump beyond boundaries and still be adjusted correctly.

Note: The modulo corrected Effective Address is written back to the register only when Pre-Modify or Post-Modify Addressing mode is used to compute the Effective Address. When an address offset (e.g., [W7 + W2]) is used, modulo address correction is performed, but the contents of the register remains unchanged.

4.3 Bit-Reversed Addressing

Bit-Reversed Addressing is intended to simplify data reordering for radix-2 FFT algorithms. It is supported by the X AGU for data writes only.

The modifier, which may be a constant value or register contents, is regarded as having its bit order reversed. The address source and destination are kept in normal order. Thus, the only operand requiring reversal is the modifier.

4.3.1 BIT-REVERSED ADDRESSING IMPLEMENTATION

Bit-Reversed Addressing is enabled when:

1. BWM (W register selection) in the MODCON register is any value other than 15 (the stack cannot be accessed using Bit-Reversed Addressing) **and**
2. the BREN bit is set in the XBREV register **and**
3. the addressing mode used is Register Indirect with Pre-Increment or Post-Increment.

If the length of a Bit-Reversed buffer is $M = 2^N$ bytes, then the last 'N' bits of the data buffer start address must be zeros.

$XB<14:0>$ is the Bit-Reversed Address modifier or 'pivot point' which is typically a constant. In the case of an FFT computation, its value is equal to half of the FFT data buffer size.

Note: All bit-reversed EA calculations assume word-sized data (LSb of every EA is always clear). The XB value is scaled accordingly to generate compatible (byte) addresses.

When enabled, Bit-Reversed Addressing will only be executed for Register Indirect with Pre-Increment or Post-Increment Addressing and word-sized data writes. It will not function for any other addressing mode or for byte-sized data, and normal addresses will be generated instead. When Bit-Reversed Addressing is active, the W address pointer will always be added to the address modifier (XB) and the offset associated with the Register Indirect Addressing mode will be ignored. In addition, as word-sized data is a requirement, the LSb of the EA is ignored (and always clear).

Note: Modulo Addressing and Bit-Reversed Addressing should not be enabled together. In the event that the user attempts to do this, Bit-Reversed Addressing will assume priority when active for the X WAGU, and X WAGU Modulo Addressing will be disabled. However, Modulo Addressing will continue to function in the X RAGU.

If Bit-Reversed Addressing has already been enabled by setting the BREN bit ($XBREV<15>$), a write to the $XBREV$ register should not be immediately followed by an indirect read operation using the W register that has been designated as the Bit-Reversed Pointer.

FIGURE 4-2: BIT-REVERSED ADDRESS EXAMPLE

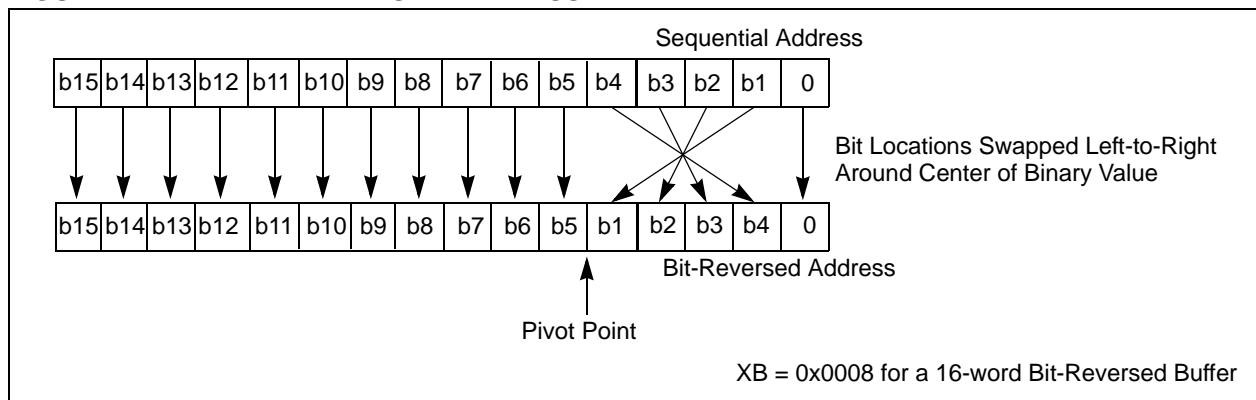

TABLE 4-2: BIT-REVERSED ADDRESS SEQUENCE (16-ENTRY)

Normal Address					Bit-Reversed Address				
A3	A2	A1	A0	Decimal	A3	A2	A1	A0	Decimal
0	0	0	0	0	0	0	0	0	0
0	0	0	1	1	1	0	0	0	8
0	0	1	0	2	0	1	0	0	4
0	0	1	1	3	1	1	0	0	12
0	1	0	0	4	0	0	1	0	2
0	1	0	1	5	1	0	1	0	10
0	1	1	0	6	0	1	1	0	6
0	1	1	1	7	1	1	1	0	14
1	0	0	0	8	0	0	0	1	1
1	0	0	1	9	1	0	0	1	9
1	0	1	0	10	0	1	0	1	5
1	0	1	1	11	1	1	0	1	13
1	1	0	0	12	0	0	1	1	3
1	1	0	1	13	1	0	1	1	11
1	1	1	0	14	0	1	1	1	7
1	1	1	1	15	1	1	1	1	15

TABLE 4-3: BIT-REVERSED ADDRESS MODIFIER VALUES FOR XBREV REGISTER

Buffer Size (Words)	XB<14:0> Bit-Reversed Address Modifier Value
4096	0x0800
2048	0x0400
1024	0x0200
512	0x0100
256	0x0080
128	0x0040
64	0x0020
32	0x0010
16	0x0008
8	0x0004
4	0x0002
2	0x0001

dsPIC30F5015/5016

NOTES:

5.0 INTERRUPTS

Note: This data sheet summarizes features of this group of dsPIC30F devices and is not intended to be a complete reference source. For more information on the CPU, peripherals, register descriptions and general device functionality, refer to the “dsPIC30F Family Reference Manual” (DS70046). For more information on the device instruction set and programming, refer to the “16-bit MCU and DSC Programmer’s Reference Manual” (DS70157).

The dsPIC30F5015/5016 has 36 interrupt sources and 4 processor exceptions (traps), which must be arbitrated based on a priority scheme.

The CPU is responsible for reading the Interrupt Vector Table (IVT) and transferring the address contained in the interrupt vector to the program counter. The interrupt vector is transferred from the program data bus into the program counter, via a 24-bit wide multiplexer on the input of the program counter.

The Interrupt Vector Table (IVT) and Alternate Interrupt Vector Table (AIVT) are placed near the beginning of program memory (0x000004). The IVT and AIVT are shown in [Figure 5-1](#).

The interrupt controller is responsible for pre-processing the interrupts and processor exceptions, prior to their being presented to the processor core. The peripheral interrupts and traps are enabled, prioritized and controlled using centralized Special Function Registers:

- IFS0<15:0>, IFS1<15:0>, IFS2<15:0>
All Interrupt Request Flags are maintained in these three registers. The flags are set by their respective peripherals or external signals, and they are cleared via software.
- IEC0<15:0>, IEC1<15:0>, IEC2<15:0>
All Interrupt Enable Control bits are maintained in these three registers. These control bits are used to individually enable interrupts from the peripherals or external signals.
- IPC0<15:0>... IPC11<7:0>
The user assignable priority level associated with each of these 44 interrupts is held centrally in these twelve registers.
- IPL<3:0>
The current CPU priority level is explicitly stored in the IPL bits. IPL<3> is present in the CORCON register, whereas IPL<2:0> are present in the STATUS register (SR) in the processor core.

- INTCON1<15:0>, INTCON2<15:0>
Global interrupt control functions are derived from these two registers. INTCON1 contains the control and status flags for the processor exceptions. The INTCON2 register controls the external interrupt request signal behavior and the use of the alternate vector table.

Note: Interrupt flag bits get set when an interrupt condition occurs, regardless of the state of its corresponding enable bit. User software should ensure the appropriate interrupt flag bits are clear prior to enabling an interrupt.

All interrupt sources can be user assigned to one of seven priority levels, 1 through 7, via the IPCx registers. Each interrupt source is associated with an interrupt vector, as shown in [Table 5-1](#). Levels 7 and 1 represent the highest and lowest maskable priorities, respectively.

Note: Assigning a priority level of 0 to an interrupt source is equivalent to disabling that interrupt.

If the NSTDIS bit (INTCON1<15>) is set, nesting of interrupts is prevented. Thus, if an interrupt is currently being serviced, processing of a new interrupt is prevented, even if the new interrupt is of higher priority than the one currently being serviced.

Note: The IPL bits become read-only whenever the NSTDIS bit has been set to ‘1’.

Certain interrupts have specialized control bits for features like edge or level triggered interrupts, interrupt-on-change, etc. Control of these features remains within the peripheral module which generates the interrupt.

The DISI instruction can be used to disable the processing of interrupts of priorities 6 and lower for a certain number of instructions, during which the DISI bit (INTCON2<14>) remains set.

When an interrupt is serviced, the PC is loaded with the address stored in the vector location in program memory that corresponds to the interrupt. There are 63 different vectors within the IVT (refer to [Figure 5-2](#)). These vectors are contained in locations 0x000004 through 0x0000FE of program memory (refer to [Figure 5-2](#)). These locations contain 24-bit addresses, and in order to preserve robustness, an address error trap will take place should the PC attempt to fetch any of these words during normal execution. This prevents execution of random data as a result of accidentally decrementing a PC into vector space, accidentally mapping a data space address into vector space or the PC rolling over to 0x000000 after reaching the end of implemented program memory space. Execution of a GOTO instruction to this vector space will also generate an address error trap.

dsPIC30F5015/5016

5.1 Interrupt Priority

The user-assignable Interrupt Priority bits (IP<2:0>) for each individual interrupt source are located in the Least Significant 3 bits of each nibble within the IPCx register(s). Bit 3 of each nibble is not used and is read as a '0'. These bits define the priority level assigned to a particular interrupt by the user.

Note: The user-assignable priority levels start at 0, as the lowest priority and level 7, as the highest priority.

Since more than one interrupt request source may be assigned to a specific user-assigned priority level, a means is provided to assign priority within a given level. This method is called "Natural Order Priority".

Natural Order Priority is determined by the position of an interrupt in the vector table, and only affects interrupt operation when multiple interrupts with the same user-assigned priority become pending at the same time.

Table 5-1 lists the interrupt numbers and interrupt sources for the dsPIC DSC devices and their associated vector numbers.

Note 1: The Natural Order Priority scheme has 0 as the highest priority and 53 as the lowest priority.

2: The Natural Order Priority number is the same as the INT number.

The ability for the user to assign every interrupt to one of seven priority levels means that the user can assign a very high overall priority level to an interrupt with a low natural order priority.

TABLE 5-1: INTERRUPT VECTOR TABLE

Interrupt Number	Vector Number	Interrupt Source
Highest Natural Order Priority		
0	8	INT0 – External Interrupt 0
1	9	IC1 – Input Capture 1
2	10	OC1 – Output Compare 1
3	11	T1 – Timer1
4	12	IC2 – Input Capture 2
5	13	OC2 – Output Compare 2
6	14	T2 – Timer2
7	15	T3 – Timer3
8	16	SPI1
9	17	U1RX – UART1 Receiver
10	18	U1TX – UART1 Transmitter
11	19	ADC – ADC Convert Done
12	20	NVM – NVM Write Complete
13	21	SI2C – I ² C™ Slave Interrupt
14	22	MI2C – I ² C Master Interrupt
15	23	Input Change Interrupt
16	24	INT1 – External Interrupt 1
17	25	Reserved
18	26	Reserved
19	27	OC3 – Output Compare 3
20	28	OC4 – Output Compare 4
21	29	T4 – Timer4
22	30	T5 – Timer5
23	31	INT2 – External Interrupt 2
24	32	Reserved
25	33	Reserved
26	34	SPI2
27	35	C1 – Combined IRQ for CAN1
28	36	IC3 – Input Capture 3
29	37	IC4 – Input Capture 4
30	38	Reserved
31	39	Reserved
32	40	Reserved
33	41	Reserved
34	42	Reserved
35	43	Reserved
36	44	INT3 – External Interrupt 3
37	45	INT4 – External Interrupt 4
38	46	Reserved
39	47	PWM – PWM Period Match
40	48	QE1 – QE1 Interrupt
41	49	Reserved
42	50	Reserved
43	51	FLTA – PWM Fault A
44	52	FLTB – PWM Fault B
45-53	53-61	Reserved
Lowest Natural Order Priority		

5.2 Reset Sequence

A Reset is not a true exception because the interrupt controller is not involved in the Reset process. The processor initializes its registers in response to a Reset which forces the PC to zero. The processor then begins program execution at location 0x000000. A `GOTO` instruction is stored in the first program memory location, immediately followed by the address target for the `GOTO` instruction. The processor executes the `GOTO` to the specified address and then begins operation at the specified target (start) address.

5.2.1 RESET SOURCES

There are 6 sources of error which will cause a device Reset.

- **Watchdog Time-out:**
The Watchdog has timed out, indicating that the processor is no longer executing the correct flow of code.
- **Uninitialized W Register Trap:**
An attempt to use an uninitialized W register as an Address Pointer will cause a Reset.
- **Illegal Instruction Trap:**
Attempted execution of any unused opcodes will result in an illegal instruction trap. Note that a fetch of an illegal instruction does not result in an illegal instruction trap if that instruction is flushed prior to execution due to a flow change.
- **Brown-out Reset (BOR):**
A momentary dip in the power supply to the device has been detected which may result in malfunction.
- **Trap Lockout:**
Occurrence of multiple trap conditions simultaneously will cause a Reset.

5.3 Traps

Traps can be considered as non-maskable interrupts indicating a software or hardware error, which adhere to a predefined priority, as shown in [Figure 5-1](#). They are intended to provide the user a means to correct erroneous operation during debug and when operating within the application.

Note: If the user does not intend to take corrective action in the event of a trap error condition, these vectors must be loaded with the address of a default handler that simply contains the `RESET` instruction. If, on the other hand, one of the vectors containing an invalid address is called, an address error trap is generated.

Note that many of these trap conditions can only be detected when they occur. Consequently, the questionable instruction is allowed to complete prior to trap exception processing. If the user chooses to recover from the error, the result of the erroneous action that caused the trap may have to be corrected.

There are 8 fixed priority levels for traps: Level 8 through Level 15, which means that IPL3 is always set during processing of a trap.

If the user is not currently executing a trap, and sets the IPL<3:0> bits to a value of '0111' (Level 7), then all interrupts are disabled, but traps can still be processed.

5.3.1 TRAP SOURCES

The following traps are provided with increasing priority. However, since all traps can be nested, priority has little effect.

Math Error Trap:

The math error trap executes under the following four circumstances:

1. Should an attempt be made to divide by zero, the divide operation will be aborted on a cycle boundary and the trap taken.
2. If enabled, a math error trap will be taken when an arithmetic operation on either Accumulator A or B causes an overflow from bit 31 and the Accumulator Guard bits are not utilized.
3. If enabled, a math error trap will be taken when an arithmetic operation on either Accumulator A or B causes a catastrophic overflow from bit 39 and all saturation is disabled.
4. If the shift amount specified in a shift instruction is greater than the maximum allowed shift amount, a trap will occur.

dsPIC30F5015/5016

Address Error Trap:

This trap is initiated when any of the following circumstances occurs:

- A misaligned data word access is attempted.
- A data fetch from unimplemented data memory location is attempted.
- A data access of an unimplemented program memory location is attempted.
- An instruction fetch from vector space is attempted.

Note: In the MAC class of instructions, wherein the data space is split into X and Y data space, unimplemented X space includes all of Y space, and unimplemented Y space includes all of X space.

5. Execution of a "BRA #literal" instruction or a "GOTO #literal" instruction, where literal is an unimplemented program memory address.
6. Executing instructions after modifying the PC to point to unimplemented program memory addresses. The PC may be modified by loading a value into the stack and executing a RETURN instruction.

Stack Error Trap:

This trap is initiated under the following conditions:

1. The Stack Pointer is loaded with a value which is greater than the (user-programmable) limit value written into the SPLIM register (stack overflow).
2. The Stack Pointer is loaded with a value which is less than 0x0800 (simple stack underflow).

Oscillator Fail Trap:

This trap is initiated if the external oscillator fails and operation becomes reliant on an internal RC backup.

5.3.2 HARD AND SOFT TRAPS

It is possible that multiple traps can become active within the same cycle (e.g., a misaligned word stack write to an overflowed address). In such a case, the fixed priority shown in Figure 5-2 is implemented, which may require the user to check if other traps are pending in order to completely correct the Fault.

'Soft' traps include exceptions of priority level 8 through level 11, inclusive. The arithmetic error trap (level 11) falls into this category of traps.

'Hard' traps include exceptions of priority level 12 through level 15, inclusive. The address error (level 12), stack error (level 13) and oscillator error (level 14) traps fall into this category.

Each hard trap that occurs must be Acknowledged before code execution of any type may continue. If a lower priority hard trap occurs while a higher priority trap is pending, acknowledged, or is being processed, a hard trap conflict will occur.

The device is automatically reset in a hard trap conflict condition. The TRAPR Status bit (RCON<15>) is set when the Reset occurs, so that the condition may be detected in software.

FIGURE 5-1: TRAP VECTORS

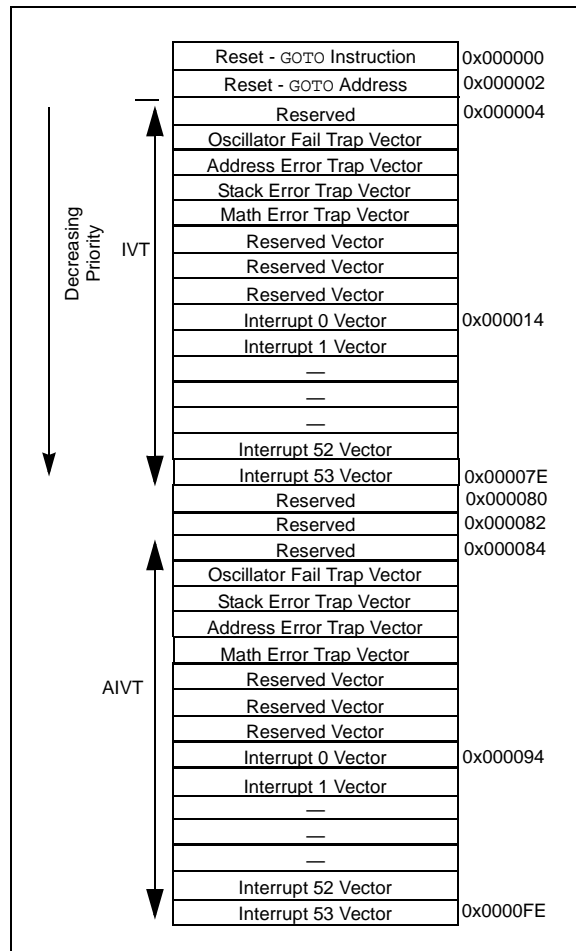

5.4 Interrupt Sequence

All interrupt event flags are sampled in the beginning of each instruction cycle by the IFSx registers. A pending Interrupt Request (IRQ) is indicated by the flag bit being equal to a '1' in an IFSx register. The IRQ will cause an interrupt to occur if the corresponding bit in the Interrupt Enable register (IECx) is set. For the remainder of the instruction cycle, the priorities of all pending interrupt requests are evaluated.

If there is a pending IRQ with a priority level greater than the current processor priority level in the IPL bits, the processor will be interrupted.

The processor then stacks the current program counter and the low byte of the processor STATUS register (SRL), as shown in Figure 5-2. The low byte of the STATUS register contains the processor priority level at the time prior to the beginning of the interrupt cycle. The processor then loads the priority level for this interrupt into the STATUS register. This action will disable all lower priority interrupts until the completion of the Interrupt Service Routine.

FIGURE 5-2: INTERRUPT STACK FRAME

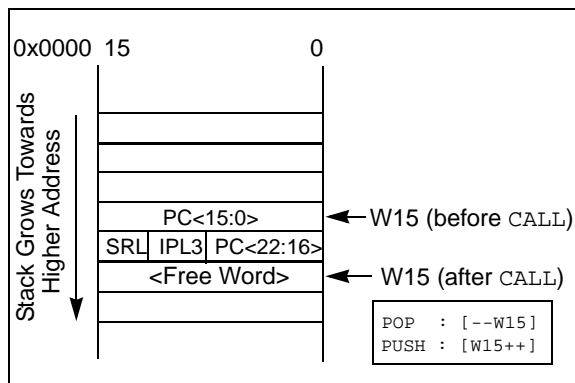

- Note 1:** The user can always lower the priority level by writing a new value into SR. The Interrupt Service Routine must clear the interrupt flag bits in the IFSx register before lowering the processor interrupt priority in order to avoid recursive interrupts.
- 2:** The IPL3 bit (CORCON<3>) is always clear when interrupts are being processed. It is set only during execution of traps.

The RETFIE (Return from Interrupt) instruction will unstack the program counter and STATUS registers to return the processor to its state prior to the interrupt sequence.

5.5 Alternate Vector Table

In program memory, the Interrupt Vector Table (IVT) is followed by the Alternate Interrupt Vector Table (AIVT), as shown in Figure 5-1. Access to the Alternate Vector Table is provided by the ALTIVT bit in the INTCON2 register. If the ALTIVT bit is set, all interrupt and exception processes will use the alternate vectors instead of the default vectors. The alternate vectors are organized in the same manner as the default vectors. The AIVT supports emulation and debugging efforts by providing a means to switch between an application and a support environment, without requiring the interrupt vectors to be reprogrammed. This feature also enables switching between applications for evaluation of different software algorithms at run time.

If the AIVT is not required, the program memory allocated to the AIVT may be used for other purposes. AIVT is not a protected section and may be freely programmed by the user.

5.6 Fast Context Saving

A context saving option is available using shadow registers. Shadow registers are provided for the DC, N, OV, Z and C bits in SR, and the registers W0 through W3. The shadows are only one level deep. The shadow registers are accessible using the PUSH.S and POP.S instructions only.

When the processor vectors to an interrupt, the PUSH.S instruction can be used to store the current value of the aforementioned registers into their respective shadow registers.

If an ISR of a certain priority uses the PUSH.S and POP.S instructions for fast context saving, then a higher priority ISR should not include the same instructions. Users must save the key registers in software during a lower priority interrupt if the higher priority ISR uses fast context saving.

5.7 External Interrupt Requests

The interrupt controller supports five external interrupt request signals, INT0-INT4. These inputs are edge sensitive; they require a low-to-high or a high-to-low transition to generate an interrupt request. The INTCON2 register has five bits, INT0EP-INT4EP, that select the polarity of the edge detection circuitry.

5.8 Wake-up from Sleep and Idle

The interrupt controller may be used to wake-up the processor from either Sleep or Idle modes, if Sleep or Idle mode is active when the interrupt is generated.

If an enabled interrupt request of sufficient priority is received by the interrupt controller, then the standard interrupt request is presented to the processor. At the same time, the processor will wake-up from Sleep or Idle and begin execution of the Interrupt Service Routine (ISR) needed to process the interrupt request.

TABLE 5-2: INTERRUPT CONTROLLER REGISTER MAP FOR dsPIC30F5015⁽¹⁾

SFR Name	ADR	Bit 15	Bit 14	Bit 13	Bit 12	Bit 11	Bit 10	Bit 9	Bit 8	Bit 7	Bit 6	Bit 5	Bit 4	Bit 3	Bit 2	Bit 1	Bit 0	Reset State	
INTCON1	0080	NSTDIS	—	—	—	—	OVATE	OVATE	COVTE	—	—	—	MATHERR	ADDRERR	STKERR	OSCFAIL	—	0000 0000 0000 0000	
INTCON2	0082	ALTIPT	DISI	—	—	—	—	—	—	—	—	—	INT4EP	INT3EP	INT2EP	INT1EP	INT0EP	0000 0000 0000 0000	
IFS0	0084	CNIF	MI2CIF	SI2CIF	NVMIF	ADIF	U1TXIF	U1RXIF	SPI1IF	T3IF	T2IF	OC2IF	IC2IF	T1IF	OC1IF	IC1IF	INT0IF	0000 0000 0000 0000	
IFS1	0086	—	—	IC4IF	IC3IF	C1IF	SPI2IF	—	—	INT2IF	T5IF	T4IF	OC4IF	OC3IF	—	—	INT1IF	0000 0000 0000 0000	
IFS2	0088	—	—	—	FLTBI	FLTAIF	—	—	QEII	PWMIF	—	INT4IF	INT3IF	—	—	—	—	0000 0000 0000 0000	
IEC0	008C	CNIE	MI2CIE	SI2CIE	NVMIE	ADIE	U1TXIE	U1RXIE	SPI1IE	T3IE	T2IE	OC2IE	IC2IE	T1IE	OC1IE	IC1IE	INT0IE	0000 0000 0000 0000	
IEC1	008E	—	—	IC4IE	IC3IE	C1IE	SPI2IE	—	—	INT2IE	T5IE	T4IE	OC4IE	OC3IE	—	—	INT1IE	0000 0000 0000 0000	
IEC2	0090	—	—	—	FLTBIE	FLTAIE	—	—	QEIE	PWMIE	—	INT4IE	INT3IE	—	—	—	—	0000 0000 0000 0000	
IPC0	0094	—	T1IP<2:0>			—	OC1IP<2:0>			—	IC1IP<2:0>			—	INT0IP<2:0>			0100 0100 0100 0100	
IPC1	0096	—	T3IP<2:0>			—	T2IP<2:0>			—	OC2IP<2:0>			—	IC2IP<2:0>			0100 0100 0100 0100	
IPC2	0098	—	ADIP<2:0>			—	U1TXIP<2:0>			—	U1RXIP<2:0>			—	SPI1IP<2:0>			0100 0100 0100 0100	
IPC3	009A	—	CNIP<2:0>			—	MI2CIP<2:0>			—	SI2CIP<2:0>			—	NVMIP<2:0>			0100 0100 0100 0100	
IPC4	009C	—	OC3IP<2:0>			—	—	—	—	—	—	—	—	—	—	INT1IP<2:0>			0100 0000 0000 0100
IPC5	009E	—	INT2IP<2:0>			—	T5IP<2:0>			—	T4IP<2:0>			—	OC4IP<2:0>			0100 0100 0100 0100	
IPC6	00A0	—	C1IP<2:0>			—	SPI2IP<2:0>			—	—	—	—	—	—	—	—	—	0100 0100 0000 0000
IPC7	00A2	—	—	—	—	—	—	—	—	—	IC4IP<2:0>			—	IC3IP<2:0>			0000 0000 0100 0100	
IPC8	00A4	—	—	—	—	—	—	—	—	—	—	—	—	—	—	—	—	0000 0000 0000 0000	
IPC9	00A6	—	PWMIP<2:0>			—	—	—	—	—	INT4IP<2:0>			—	INT3IP<2:0>			0100 0000 0100 0100	
IPC10	00A8	—	FLTAIP<2:0>			—	—	—	—	—	—	—	—	—	QEIIP<2:0>			0100 0000 0000 0100	
IPC11	00AA	—	—	—	—	—	—	—	—	—	—	—	—	—	FLTBIP<2:0>			0000 0000 0000 0100	

Legend: — = unimplemented bit, read as '0'

Note 1: Refer to the "dsPIC30F Family Reference Manual" (DS70046) for descriptions of register bit fields.

TABLE 5-3: INTERRUPT CONTROLLER REGISTER MAP FOR dsPIC30F5016⁽¹⁾

SFR Name	ADR	Bit 15	Bit 14	Bit 13	Bit 12	Bit 11	Bit 10	Bit 9	Bit 8	Bit 7	Bit 6	Bit 5	Bit 4	Bit 3	Bit 2	Bit 1	Bit 0	Reset State	
INTCON1	0080	NSTDIS	—	—	—	—	OVATE	OVBTE	COVTE	—	—	—	MATHERR	ADDRERR	STKERR	OSCFAIL	—	0000 0000 0000 0000	
INTCON2	0082	ALTIVT	—	—	—	—	—	—	—	—	—	—	INT4EP	INT3EP	INT2EP	INT1EP	INT0EP	0000 0000 0000 0000	
IFS0	0084	CNIF	MI2CIF	SI2CIF	NVMIF	ADIF	U1TXIF	U1RXIF	SPI1IF	T3IF	T2IF	OC2IF	IC2IF	T1IF	OC1IF	IC1IF	INT0IF	0000 0000 0000 0000	
IFS1	0086	—	—	IC4IF	IC3IF	C1IF	SPI2IF	—	—	INT2IF	T5IF	T4IF	OC4IF	OC3IF	—	—	INT1IF	0000 0000 0000 0000	
IFS2	0088	—	—	—	FLTBF	FLTAIF	—	—	QEIIF	PWMIF	—	INT4IF	INT3IF	—	—	—	—	0000 0000 0000 0000	
IEC0	008C	CNIE	MI2CIE	SI2CIE	NVMIE	ADIE	U1TXIE	U1RXIE	SPI1IE	T3IE	T2IE	OC2IE	IC2IE	T1IE	OC1IE	IC1IE	INT0IE	0000 0000 0000 0000	
IEC1	008E	—	—	IC4IE	IC3IE	C1IE	SPI2IE	—	—	INT2IE	T5IE	T4IE	OC4IE	OC3IE	—	—	INT1IE	0000 0000 0000 0000	
IEC2	0090	—	—	—	FLTBIE	FLTAIE	—	—	QEIIIE	PWMIE	—	INT4IE	INT3IE	—	—	—	—	0000 0000 0000 0000	
IPC0	0094	—	T1IP<2:0>			—	OC1IP<2:0>			—	IC1IP<2:0>			—	INT0IP<2:0>			0100 0100 0100 0100	
IPC1	0096	—	T31P<2:0>			—	T2IP<2:0>			—	OC2IP<2:0>			—	IC2IP<2:0>			0100 0100 0100 0100	
IPC2	0098	—	ADIP<2:0>			—	U1TXIP<2:0>			—	U1RXIP<2:0>			—	SPI1IP<2:0>			0100 0100 0100 0100	
IPC3	009A	—	CNIP<2:0>			—	MI2CIP<2:0>			—	SI2CIP<2:0>			—	NVMIP<2:0>			0100 0100 0100 0100	
IPC4	009C	—	OC3IP<2:0>			—	—	—	—	—	—	—	—	—	—	INT1IP<2:0>			0100 0000 0000 0100
IPC5	009E	—	INT2IP<2:0>			—	T5IP<2:0>			—	T4IP<2:0>			—	OC4IP<2:0>			0100 0100 0100 0100	
IPC6	00A0	—	C1IP<2:0>			—	SPI2IP<2:0>			—	—	—	—	—	—	—	—	—	0100 0100 0000 0000
IPC7	00A2	—	—	—	—	—	—	—	—	—	IC4IP<2:0>			—	IC3IP<2:0>			0000 0000 0100 0100	
IPC8	00A4	—	—	—	—	—	—	—	—	—	—	—	—	—	—	—	—	0000 0000 0000 0100	
IPC9	00A6	—	PWMIP<2:0>			—	—	—	—	—	INT4IP<2:0>			—	INT3IP<2:0>			0100 0000 0100 0100	
IPC10	00A8	—	FLTAIP<2:0>			—	—	—	—	—	—	—	—	—	—	QEIIIP<2:0>			0100 0000 0000 0100
IPC11	00AA	—	—	—	—	—	—	—	—	—	—	—	—	—	FLTBIP<2:0>			0000 0000 0000 0100	

Legend: — = unimplemented bit, read as '0'

Note 1: Refer to "dsPIC30F Family Reference Manual" (DS70046) for descriptions of register bit fields.

dsPIC30F5015/5016

NOTES:

6.0 FLASH PROGRAM MEMORY

Note: This data sheet summarizes features of this group of dsPIC30F devices and is not intended to be a complete reference source. For more information on the CPU, peripherals, register descriptions and general device functionality, refer to the “dsPIC30F Family Reference Manual” (DS70046). For more information on the device instruction set and programming, refer to the “16-bit MCU and DSC Programmer’s Reference Manual” (DS70157).

The dsPIC30F family of devices contains internal program Flash memory for executing user code. There are two methods by which the user can program this memory:

1. In-Circuit Serial Programming™ (ICSP™) programming capability
2. Run-Time Self-Programming (RTSP)

6.1 In-Circuit Serial Programming (ICSP)

dsPIC30F devices can be serially programmed while in the end application circuit. This is simply done with two lines for Programming Clock and Programming Data (which are named PGC and PGD respectively), and three other lines for Power (VDD), Ground (VSS) and

Master Clear ($\overline{\text{MCLR}}$). This allows customers to manufacture boards with unprogrammed devices, and then program the microcontroller just before shipping the product. This also allows the most recent firmware or a custom firmware to be programmed.

6.2 Run-Time Self-Programming (RTSP)

RTSP is accomplished using TBLRD (table read) and TBLWT (table write) instructions.

With RTSP, the user may erase program memory, 32 instructions (96 bytes) at a time and can write program memory data, 32 instructions (96 bytes) at a time.

6.3 Table Instruction Operation Summary

The TBLRDL and the TBLWTL instructions are used to read or write to bits<15:0> of program memory. TBLRDL and TBLWTL can access program memory in Word or Byte mode.

The TBLRDH and TBLWTH instructions are used to read or write to bits<23:16> of program memory. TBLRDH and TBLWTH can access program memory in Word or Byte mode.

A 24-bit program memory address is formed using bits<7:0> of the TBLPAG register and the Effective Address (EA) from a W register specified in the table instruction, as shown in Figure 6-1.

FIGURE 6-1: ADDRESSING FOR TABLE AND NVM REGISTERS

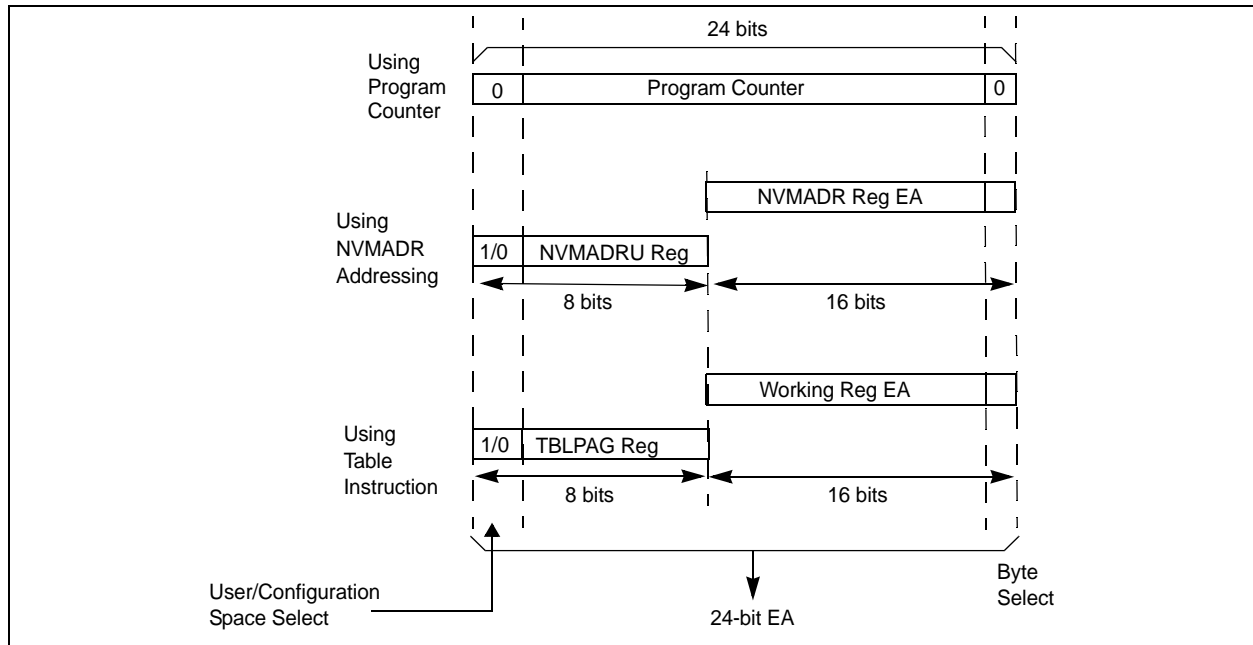

6.4 RTSP Operation

The dsPIC30F Flash program memory is organized into rows and panels. Each row consists of 32 instructions, or 96 bytes. Each panel consists of 128 rows, or 4K x 24 instructions. RTSP allows the user to erase one row (32 instructions) at a time and to program 32 instructions at one time.

Each panel of program memory contains write latches that hold 32 instructions of programming data. Prior to the actual programming operation, the write data must be loaded into the panel write latches. The data to be programmed into the panel is loaded in sequential order into the write latches; instruction 0, instruction 1, etc. The addresses loaded must always be from an even group of 32 boundary.

The basic sequence for RTSP programming is to set up a Table Pointer, then do a series of `TBLWT` instructions to load the write latches. Programming is performed by setting the special bits in the `NVMCON` register. 32 `TBLWTL` and 32 `TBLWTH` instructions are required to load the 32 instructions.

All of the table write operations are single-word writes (2 instruction cycles), because only the table latches are written.

After the latches are written, a programming operation needs to be initiated to program the data.

The Flash program memory is readable, writable and erasable during normal operation over the entire `VDD` range.

6.5 RTSP Control Registers

The four SFRs used to read and write the program Flash memory are:

- `NVMCON`
- `NVMADR`
- `NVMADRU`
- `NVMKEY`

6.5.1 NVMCON REGISTER

The `NVMCON` register controls which blocks are to be erased, which memory type is to be programmed and start of the programming cycle.

6.5.2 NVMADR REGISTER

The `NVMADR` register is used to hold the lower two bytes of the Effective Address. The `NVMADR` register captures the `EA<15:0>` of the last table instruction that has been executed and selects the row to write.

6.5.3 NVMADRU REGISTER

The `NVMADRU` register is used to hold the upper byte of the Effective Address. The `NVMADRU` register captures the `EA<23:16>` of the last table instruction that has been executed.

6.5.4 NVMKEY REGISTER

`NVMKEY` is a write-only register that is used for write protection. To start a programming or an erase sequence, the user must consecutively write `0x55` and `0xAA` to the `NVMKEY` register. Refer to [Section 6.6 “Programming Operations”](#) for further details.

<p>Note: The user can also directly write to the <code>NVMADR</code> and <code>NVMADRU</code> registers to specify a program memory address for erasing or programming.</p>
--

6.6 Programming Operations

A complete programming sequence is necessary for programming or erasing the internal Flash in RTSP mode. A programming operation is nominally 2 msec in duration and the processor stalls (waits) until the operation is finished. Setting the WR bit (NVMCON<15>) starts the operation, and the WR bit is automatically cleared when the operation is finished.

6.6.1 PROGRAMMING ALGORITHM FOR PROGRAM FLASH

The user can erase or program one row of program Flash memory at a time. The general process is:

1. Read one row of program Flash (32 instruction words) and store into data RAM as a data "image".
2. Update the data image with the desired new data.
3. Erase program Flash row.
 - a) Set up NVMCON register for multi-word, program Flash, erase, and set WREN bit.
 - b) Write address of row to be erased into NVMADRU/NVMADR.
 - c) Write 0x55 to NVMKEY.
 - d) Write 0xAA to NVMKEY.
 - e) Set the WR bit. This will begin erase cycle.
 - f) CPU will stall for the duration of the erase cycle.
 - g) The WR bit is cleared when erase cycle ends.

4. Write 32 instruction words of data from data RAM "image" into the program Flash write latches.
5. Program 32 instruction words into program Flash.
 - a) Set up NVMCON register for multi-word, program Flash, program, and set WREN bit.
 - b) Write 0x55 to NVMKEY.
 - c) Write 0xAA to NVMKEY.
 - d) Set the WR bit. This will begin program cycle.
 - e) CPU will stall for duration of the program cycle.
 - f) The WR bit is cleared by the hardware when program cycle ends.
6. Repeat steps 1 through 5 as needed to program desired amount of program Flash memory.

6.6.2 ERASING A ROW OF PROGRAM MEMORY

[Example 6-1](#) shows a code sequence that can be used to erase a row (32 instructions) of program memory.

EXAMPLE 6-1: ERASING A ROW OF PROGRAM MEMORY

```

; Setup NVMCON for erase operation, multi word write
; program memory selected, and writes enabled
MOV    #0x4041,W0          ;
MOV    W0,NVMCON          ; Init NVMCON SFR
; Init pointer to row to be ERASED
MOV    #tblpage(PROG_ADDR),W0 ;
MOV    W0,NVMADRU         ; Initialize PM Page Boundary SFR
MOV    #tbloffset(PROG_ADDR),W0 ; Intialize in-page EA[15:0] pointer
MOV    W0, NVMADR         ; Intialize NVMADR SFR
DISI   #5                 ; Block all interrupts with priority <7
                                ; for next 5 instructions

MOV    #0x55,W0           ; Write the 0x55 key
MOV    W0,NVMKEY          ;
MOV    #0xAA,W1           ;
MOV    W1,NVMKEY          ; Write the 0xAA key
BSET   NVMCON,#WR        ; Start the erase sequence
NOP    ; Insert two NOPs after the erase
NOP    ; command is asserted

```

dsPIC30F5015/5016

6.6.3 LOADING WRITE LATCHES

Example 6-2 shows a sequence of instructions that can be used to load the 96 bytes of write latches. 32 TBLWTL and 32 TBLWTH instructions are needed to load the write latches selected by the Table Pointer.

EXAMPLE 6-2: LOADING WRITE LATCHES

```
; Set up a pointer to the first program memory location to be written
; program memory selected, and writes enabled
MOV    #0x0000,W0                ;
MOV    W0,TBLPAG                 ; Initialize PM Page Boundary SFR
MOV    #0x6000,W0                ; An example program memory address
; Perform the TBLWT instructions to write the latches
; 0th_program_word
MOV    #LOW_WORD_0,W2           ;
MOV    #HIGH_BYTE_0,W3         ;
TBLWTL W2,[W0]                 ; Write PM low word into program latch
TBLWTH W3,[W0++]               ; Write PM high byte into program latch
; 1st_program_word
MOV    #LOW_WORD_1,W2           ;
MOV    #HIGH_BYTE_1,W3         ;
TBLWTL W2,[W0]                 ; Write PM low word into program latch
TBLWTH W3,[W0++]               ; Write PM high byte into program latch
; 2nd_program_word
MOV    #LOW_WORD_2,W2           ;
MOV    #HIGH_BYTE_2,W3         ;
TBLWTL W2,[W0]                 ; Write PM low word into program latch
TBLWTH W3,[W0++]               ; Write PM high byte into program latch
.
.
.
; 31st_program_word
MOV    #LOW_WORD_31,W2          ;
MOV    #HIGH_BYTE_31,W3        ;
TBLWTL W2,[W0]                 ; Write PM low word into program latch
TBLWTH W3,[W0++]               ; Write PM high byte into program latch
```

Note: In **Example 6-2**, the contents of the upper byte of W3 has no effect.

6.6.4 INITIATING THE PROGRAMMING SEQUENCE

For protection, the write initiate sequence for NVMKEY must be used to allow any erase or program operation to proceed. After the programming command has been executed, the user must wait for the programming time until programming is complete. The two instructions following the start of the programming sequence should be NOPS.

EXAMPLE 6-3: INITIATING A PROGRAMMING SEQUENCE

```
DISI    #5                        ; Block all interrupts with priority <7
                                           ; for next 5 instructions
MOV     #0x55,W0                   ; Write the 0x55 key
MOV     #0xAA,W1                   ;
MOV     W1,NVMKEY                  ; Write the 0xAA key
BSET    NVMCON,#WR                 ; Start the erase sequence
NOP                                           ; Insert two NOPS after the erase
NOP                                           ; command is asserted
```

TABLE 6-1: NVM REGISTER MAP⁽¹⁾

File Name	Addr.	Bit 15	Bit 14	Bit 13	Bit 12	Bit 11	Bit 10	Bit 9	Bit 8	Bit 7	Bit 6	Bit 5	Bit 4	Bit 3	Bit 2	Bit 1	Bit 0	All Resets
NVMCON	0760	WR	WREN	WRERR	—	—	—	—	TWRI	—	PROGOP<6:0>							0000 0000 0000 0000
NVMADR	0762	NVMADR<15:0>																uuuu uuuu uuuu uuuu
NVMADRU	0764	—	—	—	—	—	—	—	—	—	NVMADR<23:16>							0000 0000 uuuu uuuu
NVMKEY	0766	—	—	—	—	—	—	—	—	—	KEY<7:0>							0000 0000 0000 0000

Legend: u = uninitialized bit; — = unimplemented bit, read as '0'

Note 1: Refer to the "dsPIC30F Family Reference Manual" (DS70046) for descriptions of register bit fields.

dsPIC30F5015/5016

NOTES:

7.0 DATA EEPROM MEMORY

Note: This data sheet summarizes features of this group of dsPIC30F devices and is not intended to be a complete reference source. For more information on the CPU, peripherals, register descriptions and general device functionality, refer to the “dsPIC30F Family Reference Manual” (DS70046). For more information on the device instruction set and programming, refer to the “16-bit MCU and DSC Programmer’s Reference Manual” (DS70157).

The data EEPROM memory is readable and writable during normal operation over the entire VDD range. The data EEPROM memory is directly mapped in the program memory address space.

The four SFRs used to read and write the program Flash memory are used to access data EEPROM memory, as well. As described in [Section 4.0 “Address Generator Units”](#), these registers are:

- NVMCON
- NVMADR
- NVMADRU
- NVMKEY

The EEPROM data memory allows read and write of single words and 16-word blocks. When interfacing to data memory, NVMADR, in conjunction with the NVMADRU register, is used to address the EEPROM location being accessed. TBLRD and TBLWT instructions are used to read and write data EEPROM.

A word write operation should be preceded by an erase of the corresponding memory location(s). The write typically requires 2 ms to complete, but the write time will vary with voltage and temperature.

A program or erase operation on the data EEPROM does not stop the instruction flow. The user is responsible for waiting for the appropriate duration of time before initiating another data EEPROM write/erase operation. Attempting to read the data EEPROM while a programming or erase operation is in progress results in unspecified data.

Control bit WR initiates write operations, similar to program Flash writes. This bit cannot be cleared, only set, in software. This bit is cleared in hardware at the completion of the write operation. The inability to clear the WR bit in software prevents the accidental or premature termination of a write operation.

The WREN bit, when set, will allow a write operation. On power-up, the WREN bit is clear. The WRERR bit is set when a write operation is interrupted by a MCLR Reset, or a WDT Time-out Reset, during normal operation. In these situations, following Reset, the user can check the WRERR bit and rewrite the location. The address register NVMADR remains unchanged.

Note: Interrupt flag bit NVMIF in the IFS0 register is set when write is complete. It must be cleared in software.

7.1 Reading the Data EEPROM

A TBLRD instruction reads a word at the current program word address. This example uses W0 as a pointer to data EEPROM. The result is placed in register W4, as shown in [Example 7-1](#).

EXAMPLE 7-1: DATA EEPROM READ

```
MOV    #LOW_ADDR_WORD,W0    ; Init Pointer
MOV    #HIGH_ADDR_WORD,W1
MOV    W1,TBLPAG
TBLRD  [ W0 ], W4           ; read data EEPROM
```

dsPIC30F5015/5016

7.2 Erasing Data EEPROM

7.2.1 ERASING A BLOCK OF DATA EEPROM

In order to erase a block of data EEPROM, the NVMADRU and NVMADR registers must initially point to the block of memory to be erased. Configure NVMCON for erasing a block of data EEPROM, and set the ERASE and WREN bits in the NVMCON register. Setting the WR bit initiates the erase, as shown in [Example 7-2](#).

EXAMPLE 7-2: DATA EEPROM BLOCK ERASE

```
; Select data EEPROM block, ERASE, WREN bits
MOV    #4045,W0
MOV    W0,NVMCON                ; Initialize NVMCON SFR

; Start erase cycle by setting WR after writing key sequence
DISI   #5                        ; Block all interrupts with priority <7
                                           ; for next 5 instructions

MOV    #0x55,W0                  ;
MOV    W0,NVMKEY                 ; Write the 0x55 key
MOV    #0xAA,W1                  ;
MOV    W1,NVMKEY                 ; Write the 0xAA key
BSET   NVMCON,#WR                ; Initiate erase sequence
NOP
NOP

; Erase cycle will complete in 2mS. CPU is not stalled for the Data Erase Cycle
; User can poll WR bit, use NVMIF or Timer IRQ to determine erasure complete
```

7.2.2 ERASING A WORD OF DATA EEPROM

The NVMADRU and NVMADR registers must point to the block. Erase a block of data Flash and set the ERASE and WREN bits in the NVMCON register. Setting the WR bit initiates the erase, as shown in [Example 7-3](#).

EXAMPLE 7-3: DATA EEPROM WORD ERASE

```
; Select data EEPROM word, ERASE, WREN bits
MOV    #4044,W0
MOV    W0,NVMCON

; Start erase cycle by setting WR after writing key sequence
DISI   #5                        ; Block all interrupts with priority <7
                                           ; for next 5 instructions

MOV    #0x55,W0                  ;
MOV    W0,NVMKEY                 ; Write the 0x55 key
MOV    #0xAA,W1                  ;
MOV    W1,NVMKEY                 ; Write the 0xAA key
BSET   NVMCON,#WR                ; Initiate erase sequence
NOP
NOP

; Erase cycle will complete in 2mS. CPU is not stalled for the Data Erase Cycle
; User can poll WR bit, use NVMIF or Timer IRQ to determine erasure complete
```

7.3 Writing to the Data EEPROM

To write an EEPROM data location, the following sequence must be followed:

1. Erase data EEPROM word.
 - a) Select word, data EEPROM, erase and set WREN bit in NVMCON register.
 - b) Write address of word to be erased into NVMADRU/NVMADR.
 - c) Enable NVM interrupt (optional).
 - d) Write 0x55 to NVMKEY.
 - e) Write 0xAA to NVMKEY.
 - f) Set the WR bit. This will begin erase cycle.
 - g) Either poll NVMIF bit or wait for NVMIF interrupt.
 - h) The WR bit is cleared when the erase cycle ends.
2. Write data word into data EEPROM write latches.
3. Program 1 data word into data EEPROM.
 - a) Select word, data EEPROM, program and set WREN bit in NVMCON register.
 - b) Enable NVM write done interrupt (optional).
 - c) Write 0x55 to NVMKEY.
 - d) Write 0xAA to NVMKEY.
 - e) Set the WR bit. This will begin program cycle.
 - f) Either poll NVMIF bit or wait for NVM interrupt.
 - g) The WR bit is cleared when the write cycle ends.

The write will not initiate if the above sequence is not exactly followed (write 0x55 to NVMKEY, write 0xAA to NVMCON, then set WR bit) for each word. It is strongly recommended that interrupts be disabled during this code segment.

Additionally, the WREN bit in NVMCON must be set to enable writes. This mechanism prevents accidental writes to data EEPROM, due to unexpected code execution. The WREN bit should be kept clear at all times, except when updating the EEPROM. The WREN bit is not cleared by hardware.

After a write sequence has been initiated, clearing the WREN bit will not affect the current write cycle. The WR bit will be inhibited from being set unless the WREN bit is set. The WREN bit must be set on a previous instruction. Both WR and WREN cannot be set with the same instruction.

At the completion of the write cycle, the WR bit is cleared in hardware and the Nonvolatile Memory Write Complete Interrupt Flag bit (NVMIF) is set. The user may either enable this interrupt, or poll this bit. NVMIF must be cleared by software.

7.3.1 WRITING A WORD OF DATA EEPROM

Once the user has erased the word to be programmed, then a table write instruction is used to write one write latch, as shown in [Example 7-4](#).

EXAMPLE 7-4: DATA EEPROM WORD WRITE

```

; Point to data memory
MOV          #LOW_ADDR_WORD,W0          ; Init pointer
MOV          #HIGH_ADDR_WORD,W1
MOV          W1,TBLPAG
MOV          #LOW(WORD),W2              ; Get data
TBLWTL      W2,[ W0]                    ; Write data
; The NVMADR captures last table access address
; Select data EEPROM for 1 word op
MOV          #0x4004,W0
MOV          W0,NVMCON

; Operate key to allow write operation
DISI        #5                          ; Block all interrupts with priority <7
                                                ; for next 5 instructions

MOV          #0x55,W0
MOV          W0,NVMKEY                  ; Write the 0x55 key
MOV          #0xAA,W1
MOV          W1,NVMKEY                  ; Write the 0xAA key
BSET        NVMCON,#WR                  ; Initiate program sequence
NOP
NOP

; Write cycle will complete in 2mS. CPU is not stalled for the Data Write Cycle
; User can poll WR bit, use NVMIF or Timer IRQ to determine write complete

```

dsPIC30F5015/5016

7.3.2 WRITING A BLOCK OF DATA EEPROM

To write a block of data EEPROM, write to all sixteen latches first, then set the NVMCON register and program the block.

EXAMPLE 7-5: DATA EEPROM BLOCK WRITE

```
MOV      #LOW_ADDR_WORD,W0 ; Init pointer
MOV      #HIGH_ADDR_WORD,W1
MOV      W1,TBLPAG
MOV      #data1,W2          ; Get 1st data
TBLWTL   W2,[W0]++         ; write data
MOV      #data2,W2          ; Get 2nd data
TBLWTL   W2,[W0]++         ; write data
MOV      #data3,W2          ; Get 3rd data
TBLWTL   W2,[W0]++         ; write data
MOV      #data4,W2          ; Get 4th data
TBLWTL   W2,[W0]++         ; write data
MOV      #data5,W2          ; Get 5th data
TBLWTL   W2,[W0]++         ; write data
MOV      #data6,W2          ; Get 6th data
TBLWTL   W2,[W0]++         ; write data
MOV      #data7,W2          ; Get 7th data
TBLWTL   W2,[W0]++         ; write data
MOV      #data8,W2          ; Get 8th data
TBLWTL   W2,[W0]++         ; write data
MOV      #data9,W2          ; Get 9th data
TBLWTL   W2,[W0]++         ; write data
MOV      #data10,W2         ; Get 10th data
TBLWTL   W2,[W0]++        ; write data
MOV      #data11,W2         ; Get 11th data
TBLWTL   W2,[W0]++        ; write data
MOV      #data12,W2         ; Get 12th data
TBLWTL   W2,[W0]++        ; write data
MOV      #data13,W2         ; Get 13th data
TBLWTL   W2,[W0]++        ; write data
MOV      #data14,W2         ; Get 14th data
TBLWTL   W2,[W0]++        ; write data
MOV      #data15,W2         ; Get 15th data
TBLWTL   W2,[W0]++        ; write data
MOV      #data16,W2         ; Get 16th data
TBLWTL   W2,[W0]++        ; write data. The NVMADR captures last table access address.
MOV      #0x400A,W0         ; Select data EEPROM for multi word op
MOV      W0,NVMCON          ; Operate Key to allow program operation
DISI     #5                 ; Block all interrupts with priority <7
                               ; for next 5 instructions

MOV      #0x55,W0
MOV      W0,NVMKEY          ; Write the 0x55 key
MOV      #0xAA,W1
MOV      W1,NVMKEY          ; Write the 0xAA key
BSET     NVMCON,#WR         ; Start write cycle
NOP
NOP
```

7.4 Write Verify

Depending on the application, good programming practice may dictate that the value written to the memory should be verified against the original value. This should be used in applications where excessive writes can stress bits near the specification limit.

7.5 Protection Against Spurious Write

There are conditions when the device may not want to write to the data EEPROM memory. To protect against spurious EEPROM writes, various mechanisms have been built-in. On power-up, the WREN bit is cleared; also, the Power-up Timer prevents EEPROM write.

The write initiate sequence and the WREN bit together help prevent an accidental write during brown-out, power glitch or software malfunction.

8.0 I/O PORTS

Note: This data sheet summarizes features of this group of dsPIC30F devices and is not intended to be a complete reference source. For more information on the CPU, peripherals, register descriptions and general device functionality, refer to the “dsPIC30F Family Reference Manual” (DS70046). For more information on the device instruction set and programming, refer to the “16-bit MCU and DSC Programmer’s Reference Manual” (DS70157).

All of the device pins (except VDD, VSS, MCLR and OSC1/CLKI) are shared between the peripherals and the parallel I/O ports.

All I/O input ports feature Schmitt Trigger inputs for improved noise immunity.

8.1 Parallel I/O (PIO) Ports

When a peripheral is enabled and the peripheral is actively driving an associated pin, the use of the pin as a general purpose output pin is disabled. The I/O pin may be read, but the output driver for the parallel port bit will be disabled. If a peripheral is enabled, but the peripheral is not actively driving a pin, that pin may be driven by a port.

All port pins have three registers directly associated with the operation of the port pin. The data direction register (TRISx) determines whether the pin is an input or an output. If the data direction bit is a ‘1’, then the pin is an input. All port pins are defined as inputs after a

Reset. Reads from the latch (LATx), read the latch. Writes to the latch, write the latch (LATx). Reads from the port (PORTx), read the port pins and writes to the port pins, write the latch (LATx).

Any bit and its associated data and control registers that are not valid for a particular device will be disabled. That means the corresponding LATx and TRISx registers and the port pin will read as zeros.

When a pin is shared with another peripheral or function that is defined as an input only, it is nevertheless regarded as a dedicated port because there is no other competing source of outputs. An example is the INT4 pin.

The format of the registers for PORTA are shown in [Table 8-2](#).

The TRISA (Data Direction Control) register controls the direction of the RA<7:0> pins, as well as the INTx pins and the VREF pins. The LATA register supplies data to the outputs and is readable/writable. Reading the PORTA register yields the state of the input pins, while writing the PORTA register modifies the contents of the LATA register.

A parallel I/O (PIO) port that shares a pin with a peripheral is, in general, subservient to the peripheral. The peripheral’s output buffer data and control signals are provided to a pair of multiplexers. The multiplexers select whether the peripheral or the associated port has ownership of the output data and control signals of the I/O pad cell. [Figure 8-2](#) shows how ports are shared with other peripherals, and the associated I/O cell (pad) to which they are connected. [Table 8-1](#) and [Table 8-2](#) show the formats of the registers for the shared ports, PORTB through PORTG.

FIGURE 8-1: BLOCK DIAGRAM OF A DEDICATED PORT STRUCTURE

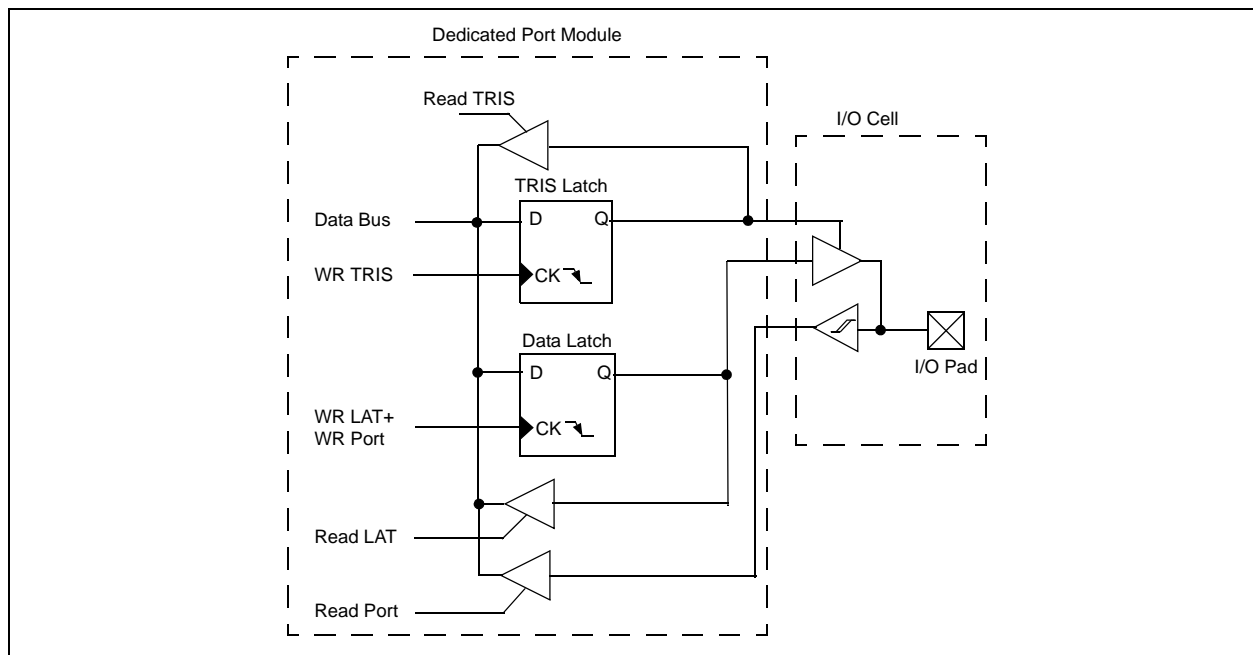

dsPIC30F5015/5016

FIGURE 8-2: BLOCK DIAGRAM OF A SHARED PORT STRUCTURE

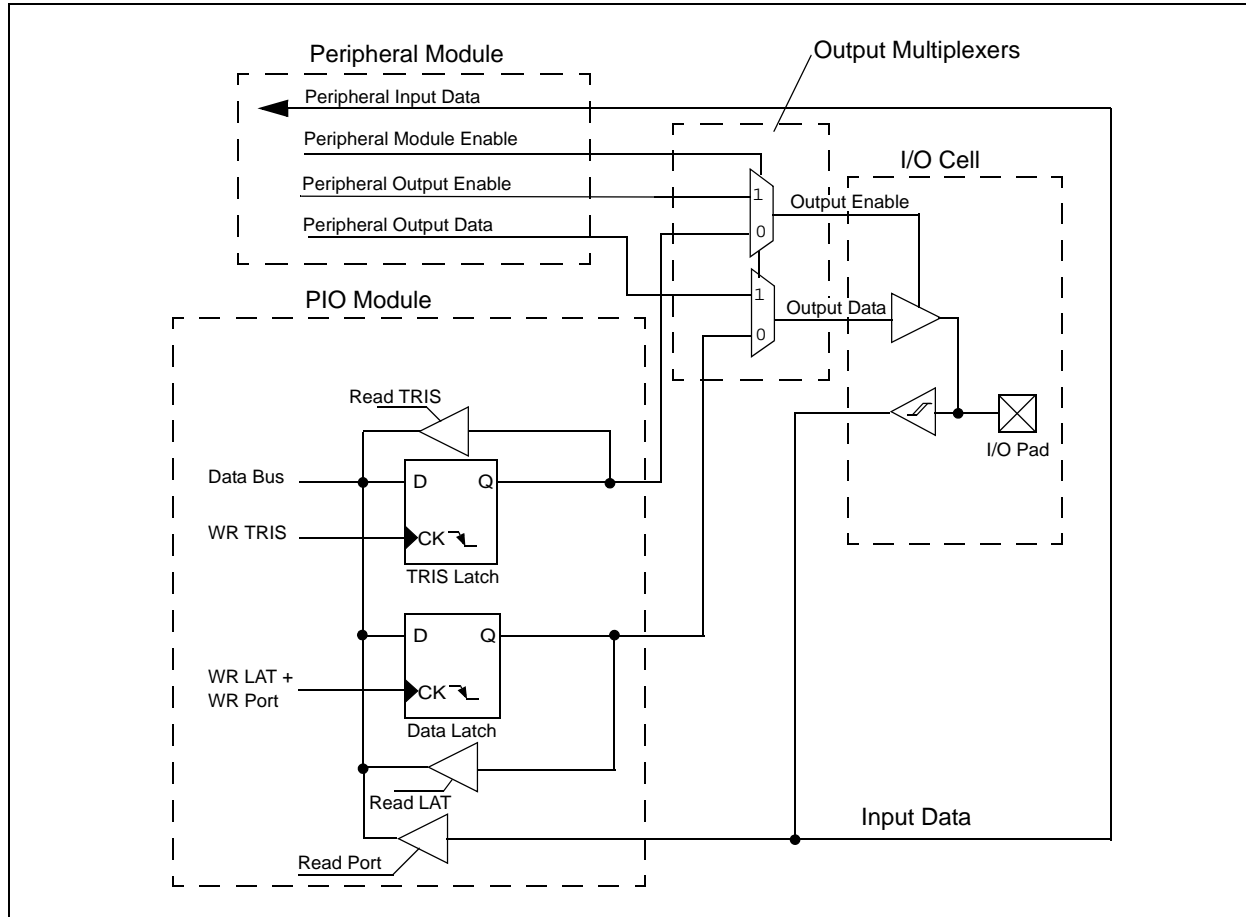

8.2 Configuring Analog Port Pins

The use of the ADPCFG and TRIS registers control the operation of the A/D port pins. The port pins that are desired as analog inputs must have their corresponding TRIS bit set (input). If the TRIS bit is cleared (output), the digital output level (VOH or VOL) will be converted.

When reading the PORT register, all pins configured as analog input channels will read as cleared (a low level).

Pins configured as digital inputs will not convert an analog input. Analog levels on any pin that is defined as a digital input (including the ANx pins) may cause the input buffer to consume current that exceeds the device specifications.

8.2.1 I/O PORT WRITE/READ TIMING

One instruction cycle is required between a port direction change or port write operation and a read operation of the same port. Typically this instruction would be a NOP.

EXAMPLE 8-1: PORT WRITE/READ EXAMPLE

```

MOV 0xFF00, W0    ; Configure PORTB<15:8>
                  ; as inputs
MOV W0, TRISBB    ; and PORTB<7:0> as outputs
NOP               ; Delay 1 cycle
BTSS PORTB, #13   ; Next Instruction
    
```

TABLE 8-1: dsPIC30F5015 PORT REGISTER MAP⁽¹⁾

SFR Name	Addr.	Bit 15	Bit 14	Bit 13	Bit 12	Bit 11	Bit 10	Bit 9	Bit 8	Bit 7	Bit 6	Bit 5	Bit 4	Bit 3	Bit 2	Bit 1	Bit 0	Reset State
TRISA	02C0	—	—	—	—	—	—	—	—	—	—	—	—	—	—	—	—	0000 0000 0000 0000
PORTA	02C2	—	—	—	—	—	—	—	—	—	—	—	—	—	—	—	—	0000 0000 0000 0000
LATA	02C4	—	—	—	—	—	—	—	—	—	—	—	—	—	—	—	—	0000 0000 0000 0000
TRISB	02C6	TRISB15	TRISB14	TRISB13	TRISB12	TRISB11	TRISB10	TRISB9	TRISB8	TRISB7	TRISB6	TRISB5	TRISB4	TRISB3	TRISB2	TRISB1	TRISB0	1111 1111 1111 1111
PORTB	02C8	RB15	RB14	RB13	RB12	RB11	RB10	RB9	RB8	RB7	RB6	RB5	RB4	RB3	RB2	RB1	RB0	0000 0000 0000 0000
LATB	02CB	LATB15	LATB14	LATB13	LATB12	LATB11	LATB10	LATB9	LATB8	LATB7	LATB6	LATB5	LATB4	LATB3	LATB2	LATB1	LATB0	0000 0000 0000 0000
TRISC	02CC	TRISC15	TRISC14	TRISC13	—	—	—	—	—	—	—	—	—	—	—	—	—	1110 0000 0000 0000
PORTC	02CE	RC15	RC14	RC13	—	—	—	—	—	—	—	—	—	—	—	—	—	0000 0000 0000 0000
LATC	02D0	LATC15	LATC14	LATC13	—	—	—	—	—	—	—	—	—	—	—	—	—	0000 0000 0000 0000
TRISD	02D2	—	—	—	—	TRISD11	TRISD10	TRISD9	TRISD8	TRISD7	TRISD6	TRISD5	TRISD4	TRISD3	TRISD2	TRISD1	TRISD0	0000 1111 1111 1111
PORTD	02D4	—	—	—	—	RD11	RD10	RD9	RD8	RD7	RD6	RD5	RD4	RD3	RD2	RD1	RD0	0000 0000 0000 0000
LATD	02D6	—	—	—	—	LATD11	LATD10	LATD9	LATD8	LATD7	LATD6	LATD5	LATD4	LATD3	LATD2	LATD1	LATD0	0000 0000 0000 0000
TRISE	02D8	—	—	—	—	—	—	—	—	TRISE7	TRISE6	TRISE5	TRISE4	TRISE3	TRISE2	TRISE1	TRISE0	0000 0000 1111 1111
PORTE	02DA	—	—	—	—	—	—	—	—	RE7	RE6	RE5	RE4	RE3	RE2	RE1	RE0	0000 0000 0000 0000
LATE	02DC	—	—	—	—	—	—	—	—	LATE7	LATE6	LATE5	LATE4	LATE3	LATE2	LATE1	LATE0	0000 0000 0000 0000
TRISF	02EE	—	—	—	—	—	—	—	—	—	TRISF6	TRISF5	TRISF4	TRISF3	TRISF2	TRISF1	TRISF0	0000 0000 0111 1111
PORTF	02E0	—	—	—	—	—	—	—	—	—	RF6	RF5	RF4	RF3	RF2	RF1	RF0	0000 0000 0000 0000
LATF	02E2	—	—	—	—	—	—	—	—	—	LATF6	LATF5	LATF4	LATF3	LATF2	LATF1	LATF0	0000 0000 0000 0000
TRISG	02E4	—	—	—	—	—	—	TRISG9	TRISG8	TRISG7	TRISG6	—	—	TRISG3	TRISG2	—	—	0000 0011 1100 1100
PORTG	02E6	—	—	—	—	—	—	RG9	RG8	RG7	RG6	—	—	RG3	RG2	—	—	0000 0000 0000 0000
LATG	02E8	—	—	—	—	—	—	LATG9	LATG8	LATG7	LATG6	—	—	LATG3	LATG2	—	—	0000 0000 0000 0000

Legend: — = unimplemented bit, read as '0'

Note 1: Refer to the "dsPIC30F Family Reference Manual" (DS70046) for descriptions of register bit fields.

TABLE 8-2: dsPIC30F5016 PORT REGISTER MAP⁽¹⁾

SFR Name	Addr.	Bit 15	Bit 14	Bit 13	Bit 12	Bit 11	Bit 10	Bit 9	Bit 8	Bit 7	Bit 6	Bit 5	Bit 4	Bit 3	Bit 2	Bit 1	Bit 0	Reset State
TRISA	02C0	TRISA15	TRISA14	—	—	—	TRISA10	TRISA9	—	—	—	—	—	—	—	—	—	1100 0110 0000 0000
PORTA	02C2	RA15	RA14	—	—	—	RA10	RA9	—	—	—	—	—	—	—	—	—	0000 0000 0000 0000
LATA	02C4	LATA15	LATA14	—	—	—	LATA10	LATA9	—	—	—	—	—	—	—	—	—	0000 0000 0000 0000
TRISB	02C6	TRISB15	TRISB14	TRISB13	TRISB12	TRISB11	TRISB10	TRISB9	TRISB8	TRISB7	TRISB6	TRISB5	TRISB4	TRISB3	TRISB2	TRISB1	TRISB0	1111 1111 1111 1111
PORTB	02C8	RB15	RB14	RB13	RB12	RB11	RB10	RB9	RB8	RB7	RB6	RB5	RB4	RB3	RB2	RB1	RB0	0000 0000 0000 0000
LATB	02CB	LATB15	LATB14	LATB13	LATB12	LATB11	LATB10	LATB9	LATB8	LATB7	LATB6	LATB5	LATB4	LATB3	LATB2	LATB1	LATB0	0000 0000 0000 0000
TRISC	02CC	TRISC15	TRISC14	TRISC13	—	—	—	—	—	—	—	—	—	TRISC3	—	TRISC1	—	1110 0000 0000 1010
PORTC	02CE	RC15	RC14	RC13	—	—	—	—	—	—	—	—	—	RC3	—	RC1	—	0000 0000 0000 0000
LATC	02D0	LATC15	LATC14	LATC13	—	—	—	—	—	—	—	—	—	LATC3	—	LATC1	—	0000 0000 0000 0000
TRISD	02D2	TRISD15	TRISD14	TRISD13	TRISD12	TRISD11	TRISD10	TRISD9	TRISD8	TRISD7	TRISD6	TRISD5	TRISD4	TRISD3	TRISD2	TRISD1	TRISD0	1111 1111 1111 1111
PORTD	02D4	RD15	RD14	RD13	RD12	RD11	RD10	RD9	RD8	RD7	RD6	RD5	RD4	RD3	RD2	RD1	RD0	0000 0000 0000 0000
LATD	02D6	LATD15	LATD14	LATD13	LATD12	LATD11	LATD10	LATD9	LATD8	LATD7	LATD6	LATD5	LATD4	LATD3	LATD2	LATD1	LATD0	0000 0000 0000 0000
TRISE	02D8	—	—	—	—	—	—	TRISE9	TRISE8	TRISE7	TRISE6	TRISE5	TRISE4	TRISE3	TRISE2	TRISE1	TRISE0	0000 0011 1111 1111
PORTE	02DA	—	—	—	—	—	—	RE9	RE8	RE7	RE6	RE5	RE4	RE3	RE2	RE1	RE0	0000 0000 0000 0000
LATE	02DC	—	—	—	—	—	—	LATE9	LATE8	LATE7	LATE6	LATE5	LATE4	LATE3	LATE2	LATE1	LATE0	0000 0000 0000 0000
TRISF	02EE	—	—	—	—	—	—	—	TRISF8	TRISF7	TRISF6	TRISF5	TRISF4	TRISF3	TRISF2	TRISF1	TRISF0	0000 0001 1111 1111
PORTF	02E0	—	—	—	—	—	—	—	RF8	RF7	RF6	RF5	RF4	RF3	RF2	RF1	RF0	0000 0000 0000 0000
LATF	02E2	—	—	—	—	—	—	—	LATF8	LATF7	LATF6	LATF5	LATF4	LATF3	LATF2	LATF1	LATF0	0000 0000 0000 0000
TRISG	02E4	—	—	—	—	—	—	TRISG9	TRISG8	TRISG7	TRISG6	—	—	TRISG3	TRISG2	TRISG1	TRISG0	0000 0011 1100 1111
PORTG	02E6	—	—	—	—	—	—	RG9	RG8	RG7	RG6	—	—	RG3	RG2	RG1	RG0	0000 0000 0000 0000
LATG	02E8	—	—	—	—	—	—	LATG9	LATG8	LATG7	LATG6	—	—	LATG3	LATG2	LATG1	LATG0	0000 0000 0000 0000

Legend: — = unimplemented bit, read as '0'

Note 1: Refer to the "dsPIC30F Family Reference Manual" (DS70046) for descriptions of register bit fields.

8.3 Input Change Notification Module

The input change notification module provides the dsPIC30F devices the ability to generate interrupt requests to the processor in response to a change-of-state on selected input pins. This module is capable of detecting input change-of-states, even in Sleep mode

when the clocks are disabled. There are 22 external signals (CN0 through CN21) that may be selected (enabled) for generating an interrupt request on a change-of-state.

Please refer to the pin diagrams for CN pin locations.

TABLE 8-3: INPUT CHANGE NOTIFICATION REGISTER MAP (BITS 15-8) FOR dsPIC30F5015⁽¹⁾

SFR Name	Addr.	Bit 15	Bit 14	Bit 13	Bit 12	Bit 11	Bit 10	Bit 9	Bit 8	Reset State
CNEN1	00C0	CN15IE	CN14IE	CN13IE	CN12IE	CN11IE	CN10IE	CN9IE	CN8IE	0000 0000 0000 0000
CNEN2	00C2	—	—	—	—	—	—	—	—	0000 0000 0000 0000
CNPU1	00C4	CN15PUE	CN14PUE	CN13PUE	CN12PUE	CN11PUE	CN10PUE	CN9PUE	CN8PUE	0000 0000 0000 0000
CNPU2	00C6	—	—	—	—	—	—	—	—	0000 0000 0000 0000

Legend: — = unimplemented bit, read as '0'

Note 1: Refer to the "dsPIC30F Family Reference Manual" (DS70046) for descriptions of register bit fields.

TABLE 8-4: INPUT CHANGE NOTIFICATION REGISTER MAP (BITS 7-0) FOR dsPIC30F5015⁽¹⁾

SFR Name	Addr.	Bit 7	Bit 6	Bit 5	Bit 4	Bit 3	Bit 2	Bit 1	Bit 0	Reset State
CNEN1	00C0	CN7IE	CN6IE	CN5IE	CN4IE	CN3IE	CN2IE	CN1IE	CN0IE	0000 0000 0000 0000
CNEN2	00C2	—	—	—	—	—	CN18IE	CN17IE	CN16IE	0000 0000 0000 0000
CNPU1	00C4	CN7PUE	CN6PUE	CN5PUE	CN4PUE	CN3PUE	CN2PUE	CN1PUE	CN0PUE	0000 0000 0000 0000
CNPU2	00C6	—	—	—	—	—	CN18PUE	CN17PUE	CN16PUE	0000 0000 0000 0000

Legend: — = unimplemented bit, read as '0'

Note 1: Refer to the "dsPIC30F Family Reference Manual" (DS70046) for descriptions of register bit fields.

TABLE 8-5: INPUT CHANGE NOTIFICATION REGISTER MAP (BITS 15-8) FOR dsPIC30F5016⁽¹⁾

SFR Name	Addr.	Bit 15	Bit 14	Bit 13	Bit 12	Bit 11	Bit 10	Bit 9	Bit 8	Reset State
CNEN1	00C0	CN15IE	CN14IE	CN13IE	CN12IE	CN11IE	CN10IE	CN9IE	CN8IE	0000 0000 0000 0000
CNEN2	00C2	—	—	—	—	—	—	—	—	0000 0000 0000 0000
CNPU1	00C4	CN15PUE	CN14PUE	CN13PUE	CN12PUE	CN11PUE	CN10PUE	CN9PUE	CN8PUE	0000 0000 0000 0000
CNPU2	00C6	—	—	—	—	—	—	—	—	0000 0000 0000 0000

Legend: — = unimplemented bit, read as '0'

Note 1: Refer to the "dsPIC30F Family Reference Manual" (DS70046) for descriptions of register bit fields.

TABLE 8-6: INPUT CHANGE NOTIFICATION REGISTER MAP (BITS 7-0) FOR dsPIC30F5016⁽¹⁾

SFR Name	Addr.	Bit 7	Bit 6	Bit 5	Bit 4	Bit 3	Bit 2	Bit 1	Bit 0	Reset State
CNEN1	00C0	CN7IE	CN6IE	CN5IE	CN4IE	CN3IE	CN2IE	CN1IE	CN0IE	0000 0000 0000 0000
CNEN2	00C2	—	—	CN21IE	CN20IE	CN19IE	CN18IE	CN17IE	CN16IE	0000 0000 0000 0000
CNPU1	00C4	CN7PUE	CN6PUE	CN5PUE	CN4PUE	CN3PUE	CN2PUE	CN1PUE	CN0PUE	0000 0000 0000 0000
CNPU2	00C6	—	—	CN21PUE	CN20PUE	CN19PUE	CN18PUE	CN17PUE	CN16PUE	0000 0000 0000 0000

Legend: — = unimplemented bit, read as '0'

Note 1: Refer to the "dsPIC30F Family Reference Manual" (DS70046) for descriptions of register bit fields.

dsPIC30F5015/5016

NOTES:

9.0 TIMER1 MODULE

Note: This data sheet summarizes features of this group of dsPIC30F devices and is not intended to be a complete reference source. For more information on the CPU, peripherals, register descriptions and general device functionality, refer to the “dsPIC30F Family Reference Manual” (DS70046). For more information on the device instruction set and programming, refer to the “16-bit MCU and DSC Programmer’s Reference Manual” (DS70157).

This section describes the 16-bit General Purpose (GP) Timer1 module and associated operational modes.

Note: Timer1 is a Type A timer. Please refer to the specifications for a Type A timer in [Section 24.0 Electrical Characteristics](#) of this document.

The following sections provide a detailed description, including setup and control registers along with associated block diagrams for the operational modes of the timers.

The Timer1 module is a 16-bit timer which can serve as the time counter for the real-time clock, or operate as a free-running interval timer/counter. The 16-bit timer has the following modes:

- 16-bit Timer
- 16-bit Synchronous Counter
- 16-bit Asynchronous Counter

Further, the following operational characteristics are supported:

- Timer gate operation
- Selectable prescaler settings
- Timer operation during CPU Idle and Sleep modes
- Interrupt on 16-bit Period register match or falling edge of external gate signal

These operating modes are determined by setting the appropriate bit(s) in the 16-bit SFR, T1CON. [Figure 9-1](#) presents a block diagram of the 16-bit timer module.

16-bit Timer Mode: In the 16-bit Timer mode, the timer increments on every instruction cycle up to a match value, preloaded into the Period register, PR1, then resets to ‘0’ and continues to count.

When the CPU goes into the Idle mode, the timer will stop incrementing, unless the TSIDL (T1CON<13>) bit = 0. If TSIDL = 1, the timer module logic will resume the incrementing sequence upon termination of the CPU Idle mode.

16-bit Synchronous Counter Mode: In the 16-bit Synchronous Counter mode, the timer increments on the rising edge of the applied external clock signal, which is synchronized with the internal phase clocks. The timer counts up to a match value preloaded in PR1, then resets to ‘0’ and continues.

When the CPU goes into the Idle mode, the timer will stop incrementing, unless the respective TSIDL bit = 0. If TSIDL = 1, the timer module logic will resume the incrementing sequence upon termination of the CPU Idle mode.

16-bit Asynchronous Counter Mode: In the 16-bit Asynchronous Counter mode, the timer increments on every rising edge of the applied external clock signal. The timer counts up to a match value preloaded in PR1, then resets to ‘0’ and continues.

When the timer is configured for the Asynchronous mode of operation and the CPU goes into the Idle mode, the timer will stop incrementing if TSIDL = 1.

9.4 Timer Interrupt

The 16-bit timer has the ability to generate an interrupt on period match. When the timer count matches the Period register, the T1IF bit is asserted and an interrupt will be generated, if enabled. The T1IF bit must be cleared in software. The Timer Interrupt Flag, T1IF, is located in the IFS0 Control register in the interrupt controller.

When the Gated Time Accumulation mode is enabled, an interrupt will also be generated on the falling edge of the gate signal (at the end of the accumulation cycle).

Enabling an interrupt is accomplished via the respective Timer Interrupt Enable bit, T1IE. The Timer Interrupt Enable bit is located in the IEC0 Control register in the interrupt controller.

9.5 Real-Time Clock

Timer1, when operating in Real-Time Clock (RTC) mode, provides time-of-day and event time-stamping capabilities. Key operational features of the RTC are:

- Operation from 32 kHz LP oscillator
- 8-bit prescaler
- Low power
- Real-Time Clock Interrupts

These operating modes are determined by setting the appropriate bit(s) in the T1CON Control register.

9.5.1 RTC OSCILLATOR OPERATION

When the TON = 1, TCS = 1 and TGATE = 0, the timer increments on the rising edge of the 32 kHz LP oscillator output signal, up to the value specified in the Period register, and is then reset to '0'.

The TSYNC bit must be asserted to a logic '0' (Asynchronous mode) for correct operation.

Enabling LPOSCEN (OSCCON<1>) will disable the normal Timer and Counter modes and enable a timer carry-out wake-up event.

When the CPU enters Sleep mode, the RTC will continue to operate, provided the 32 kHz external crystal oscillator is active and the control bits have not been changed. The TSIDL bit should be cleared to '0' in order for RTC to continue operation in Idle mode.

9.5.2 RTC INTERRUPTS

When an interrupt event occurs, the respective interrupt flag, T1IF, is asserted and an interrupt will be generated, if enabled. The T1IF bit must be cleared in software. The respective Timer Interrupt Flag, T1IF, is located in the IFS0 Status register in the interrupt controller.

Enabling an interrupt is accomplished via the respective Timer Interrupt Enable bit, T1IE. The Timer Interrupt Enable bit is located in the IEC0 Control register in the interrupt controller.

FIGURE 9-2: RECOMMENDED COMPONENTS FOR TIMER1 LP OSCILLATOR RTC

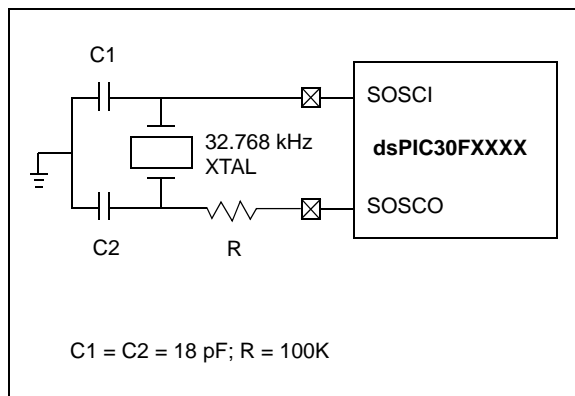

TABLE 9-1: TIMER1 REGISTER MAP⁽¹⁾

SFR Name	Addr.	Bit 15	Bit 14	Bit 13	Bit 12	Bit 11	Bit 10	Bit 9	Bit 8	Bit 7	Bit 6	Bit 5	Bit 4	Bit 3	Bit 2	Bit 1	Bit 0	Reset State
TMR1	0100	Timer1 Register																uuuu uuuu uuuu uuuu
PR1	0102	Period Register 1																1111 1111 1111 1111
T1CON	0104	TON	—	TSIDL	—	—	—	—	—	—	TGATE	TCKPS1	TCKPS0	—	TSYNC	TCS	—	0000 0000 0000 0000

Legend: u = uninitialized bit; — = unimplemented bit, read as '0'

Note 1: Refer to the "dsPIC30F Family Reference Manual" (DS70046) for descriptions of register bit fields.

10.0 TIMER2/3 MODULE

Note: This data sheet summarizes features of this group of dsPIC30F devices and is not intended to be a complete reference source. For more information on the CPU, peripherals, register descriptions and general device functionality, refer to the “dsPIC30F Family Reference Manual” (DS70046). For more information on the device instruction set and programming, refer to the “16-bit MCU and DSC Programmer’s Reference Manual” (DS70157).

This section describes the 32-bit General Purpose (GP) timer module (Timer2/3) and associated operational modes. Figure 10-1 depicts the simplified block diagram of the 32-bit Timer2/3 module. Figure 10-2 and Figure 10-3 show Timer2/3 configured as two independent 16-bit timers: Timer2 and Timer3, respectively.

Note: Timer2 is a Type B timer and Timer3 is a Type C timer. Please refer to the appropriate timer type in Section 24.0 “Electrical Characteristics”.

The Timer2/3 module is a 32-bit timer, which can be configured as two 16-bit timers, with selectable operating modes. These timers are utilized by other peripheral modules such as:

- Input Capture
- Output Compare/Simple PWM

The following sections provide a detailed description, including setup and control registers, along with associated block diagrams for the operational modes of the timers.

The 32-bit timer has the following modes:

- Two independent 16-bit timers (Timer2 and Timer3) with all 16-bit operating modes (except Asynchronous Counter mode)
- Single 32-bit Timer operation
- Single 32-bit Synchronous Counter

Further, the following operational characteristics are supported:

- ADC Event Trigger
- Timer Gate Operation
- Selectable Prescaler Settings
- Timer Operation during Idle and Sleep modes
- Interrupt on a 32-bit Period register Match

These operating modes are determined by setting the appropriate bit(s) in the 16-bit T2CON and T3CON SFRs.

For 32-bit timer/counter operation, Timer2 is the least significant word and Timer3 is the most significant word of the 32-bit timer.

Note: For 32-bit timer operation, T3CON control bits are ignored. Only T2CON control bits are used for setup and control. Timer2 clock and gate inputs are utilized for the 32-bit timer module, but an interrupt is generated with the Timer3 Interrupt Flag (T3IF) and the interrupt is enabled with the Timer3 Interrupt Enable bit (T3IE).

16-bit Mode: In 16-bit mode, Timer2 and Timer3 can be configured as two independent 16-bit timers. Each timer can be set up in either 16-bit Timer mode or 16-bit Synchronous Counter mode. See Section 9.0 “Timer1 Module” for details on these two operating modes.

The only functional difference between Timer2 and Timer3 is that Timer2 provides synchronization of the clock prescaler output. This is useful for high-frequency external clock inputs.

32-bit Timer Mode: In the 32-bit Timer mode, the timer increments on every instruction cycle up to a match value, preloaded into the combined 32-bit Period register, PR3/PR2, then resets to ‘0’ and continues to count.

For synchronous 32-bit reads of the Timer2/Timer3 pair, reading the least significant word (TMR2 register) will cause the most significant word to be read and latched into a 16-bit holding register, termed TMR3HLD.

For synchronous 32-bit writes, the holding register (TMR3HLD) must first be written to. When followed by a write to the TMR2 register, the contents of TMR3HLD will be transferred and latched into the MSB of the 32-bit timer (TMR3).

32-bit Synchronous Counter Mode: In the 32-bit Synchronous Counter mode, the timer increments on the rising edge of the applied external clock signal, which is synchronized with the internal phase clocks. The timer counts up to a match value preloaded in the combined 32-bit Period register, PR3/PR2, then resets to ‘0’ and continues.

When the timer is configured for the Synchronous Counter mode of operation and the CPU goes into the Idle mode, the timer will stop incrementing, unless the TSIDL (T2CON<13>) bit = 0. If TSIDL = 1, the timer module logic will resume the incrementing sequence upon termination of the CPU Idle mode.

FIGURE 10-2: 16-BIT TIMER2 BLOCK DIAGRAM (TYPE B TIMER)

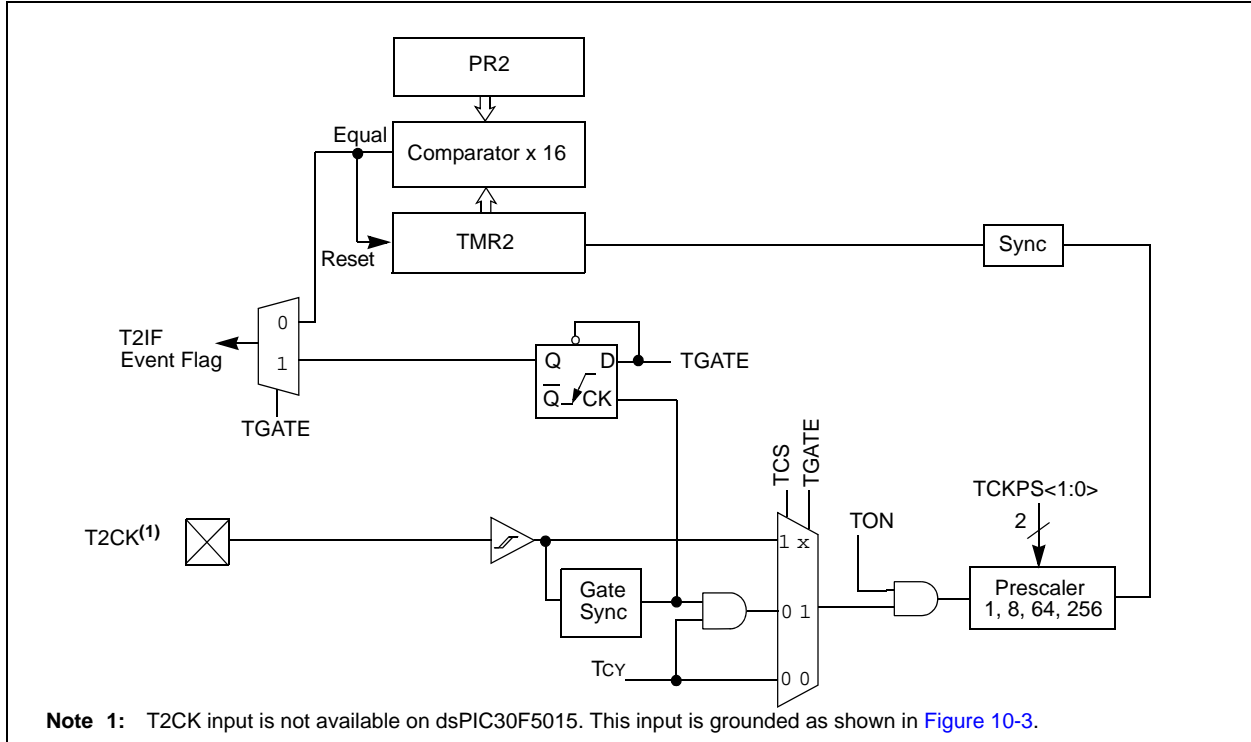
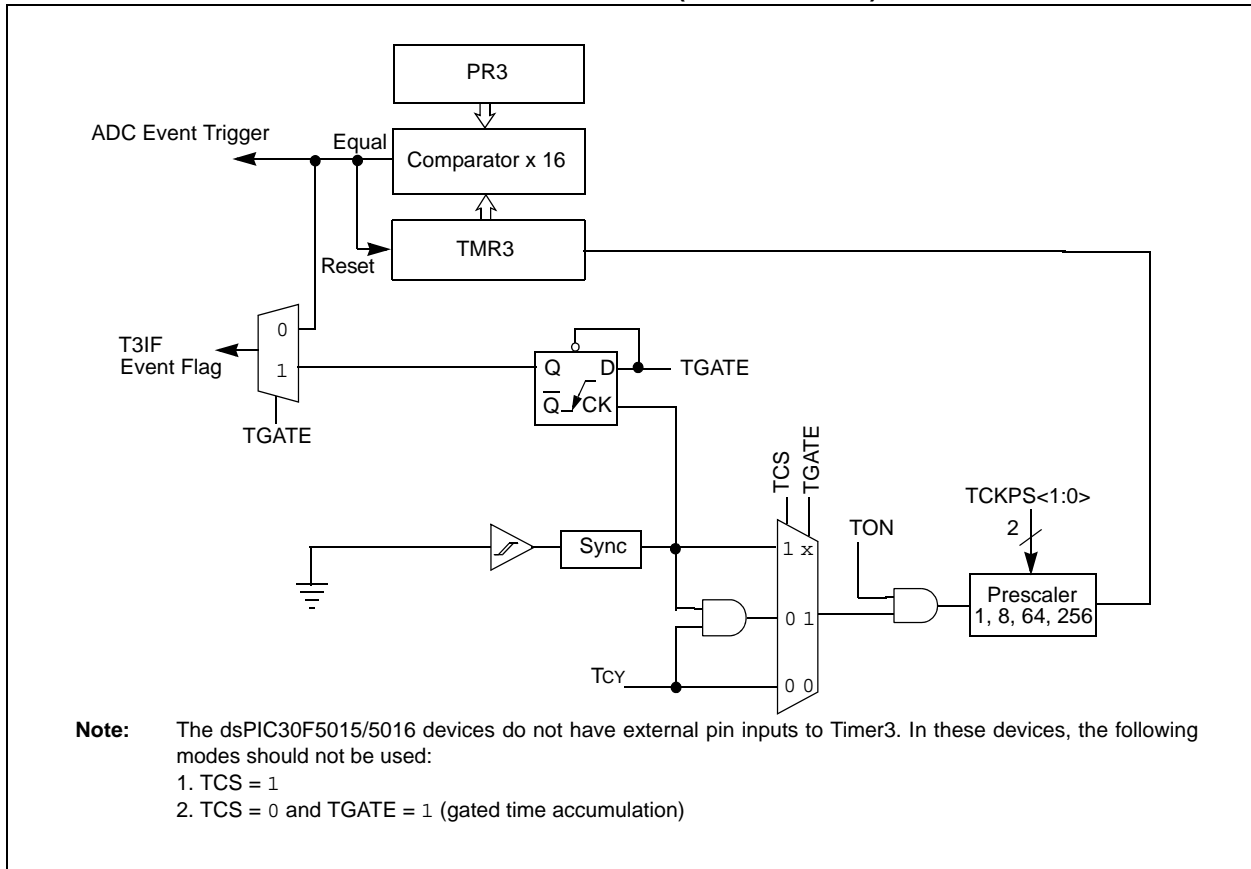

FIGURE 10-3: 16-BIT TIMER3 BLOCK DIAGRAM (TYPE C TIMER)



10.1 Timer Gate Operation

The 32-bit timer can be placed in the Gated Time Accumulation mode. This mode allows the internal Tcy to increment the respective timer when the gate input signal (T2CK pin) is asserted high. Control bit TGATE (T2CON<6>) must be set to enable this mode. When in this mode, Timer2 is the originating clock source. The TGATE setting is ignored for Timer3. The timer must be enabled (TON = 1) and the timer clock source set to internal (TCS = 0).

The falling edge of the external signal terminates the count operation, but does not reset the timer. The user must reset the timer in order to start counting from zero.

10.2 ADC Event Trigger

When a match occurs between the 32-bit timer (TMR3/TMR2) and the 32-bit combined Period register (PR3/PR2), a special ADC trigger event signal is generated by Timer3.

10.3 Timer Prescaler

The input clock (FOSC/4 or external clock) to the timer has a prescale option of 1:1, 1:8, 1:64 and 1:256 selected by control bits TCKPS<1:0> (T2CON<5:4> and T3CON<5:4>). For the 32-bit timer operation, the originating clock source is Timer2. The prescaler operation for Timer3 is not applicable in this mode. The prescaler counter is cleared when any of the following occurs:

- write to the TMR2/TMR3 register
- clearing either of the TON (T2CON<15> or T3CON<15>) bits to '0'
- device Reset, such as POR and BOR

However, if the timer is disabled (TON = 0), then the Timer2 prescaler cannot be reset, since the prescaler clock is halted.

TMR2/TMR3 is not cleared when T2CON/T3CON is written.

10.4 Timer Operation During Sleep Mode

During CPU Sleep mode, the timer will not operate, because the internal clocks are disabled.

10.5 Timer Interrupt

The 32-bit timer module can generate an interrupt on period match, or on the falling edge of the external gate signal. When the 32-bit timer count matches the respective 32-bit Period register, or the falling edge of the external "gate" signal is detected, the T3IF bit (IFS0<7>) is asserted and an interrupt will be generated if enabled. In this mode, the T3IF interrupt flag is used as the source of the interrupt. The T3IF bit must be cleared in software.

Enabling an interrupt is accomplished via the respective Timer Interrupt Enable bit, T3IE (IEC0<7>).

TABLE 10-1: TIMER2/3 REGISTER MAP⁽¹⁾

SFR Name	Addr.	Bit 15	Bit 14	Bit 13	Bit 12	Bit 11	Bit 10	Bit 9	Bit 8	Bit 7	Bit 6	Bit 5	Bit 4	Bit 3	Bit 2	Bit 1	Bit 0	Reset State
TMR2	0106	Timer2 Register																uuuu uuuu uuuu uuuu
TMR3HLD	0108	Timer3 Holding Register (For 32-bit timer operations only)																uuuu uuuu uuuu uuuu
TMR3	010A	Timer3 Register																uuuu uuuu uuuu uuuu
PR2	010C	Period Register 2																1111 1111 1111 1111
PR3	010E	Period Register 3																1111 1111 1111 1111
T2CON	0110	TON	—	TSIDL	—	—	—	—	—	—	TGATE	TCKPS1	TCKPS0	T32	—	TCS ⁽²⁾	—	0000 0000 0000 0000
T3CON	0112	TON	—	TSIDL	—	—	—	—	—	—	TGATE	TCKPS1	TCKPS0	—	—	—	—	0000 0000 0000 0000

Legend: u = uninitialized bit; — = unimplemented bit, read as '0'

Note 1: Refer to the "dsPIC30F Family Reference Manual" (DS70046) for descriptions of register bit fields.

Note 2: This bit is not available in dsPIC30F5015 devices.

dsPIC30F5015/5016

NOTES:

11.0 TIMER4/5 MODULE

Note: This data sheet summarizes features of this group of dsPIC30F devices and is not intended to be a complete reference source. For more information on the CPU, peripherals, register descriptions and general device functionality, refer to the “dsPIC30F Family Reference Manual” (DS70046). For more information on the device instruction set and programming, refer to the “16-bit MCU and DSC Programmer’s Reference Manual” (DS70157).

This section describes the second 32-bit General Purpose timer module (Timer4/5) and associated operational modes. Figure 11-1 depicts the simplified block diagram of the 32-bit Timer4/5 module. Figure 11-2 and Figure 11-3 show Timer4/5 configured as two independent 16-bit timers, Timer4 and Timer5, respectively.

Note: Timer4 is a Type B timer and Timer5 is a Type C timer. Please refer to the appropriate timer type in Section 24.0 “Electrical Characteristics”.

The Timer4/5 module is similar in operation to the Timer2/3 module. However, there are some differences, which are listed below:

- The Timer4/5 module does not support the ADC Event Trigger feature
- Timer4/5 cannot be utilized by other peripheral modules such as Input Capture and Output Compare

The operating modes of the Timer4/5 module are determined by setting the appropriate bit(s) in the 16-bit T4CON and T5CON SFRs.

For 32-bit timer/counter operation, Timer4 is the least significant word and Timer5 is the most significant word of the 32-bit timer.

Note: For 32-bit timer operation, T5CON control bits are ignored. Only T4CON control bits are used for setup and control. Timer4 clock and gate inputs are utilized for the 32-bit timer module, but an interrupt is generated with the Timer5 Interrupt Flag (T5IF) and the interrupt is enabled with the Timer5 Interrupt Enable bit (T5IE).

FIGURE 11-1: 32-BIT TIMER4/5 BLOCK DIAGRAM

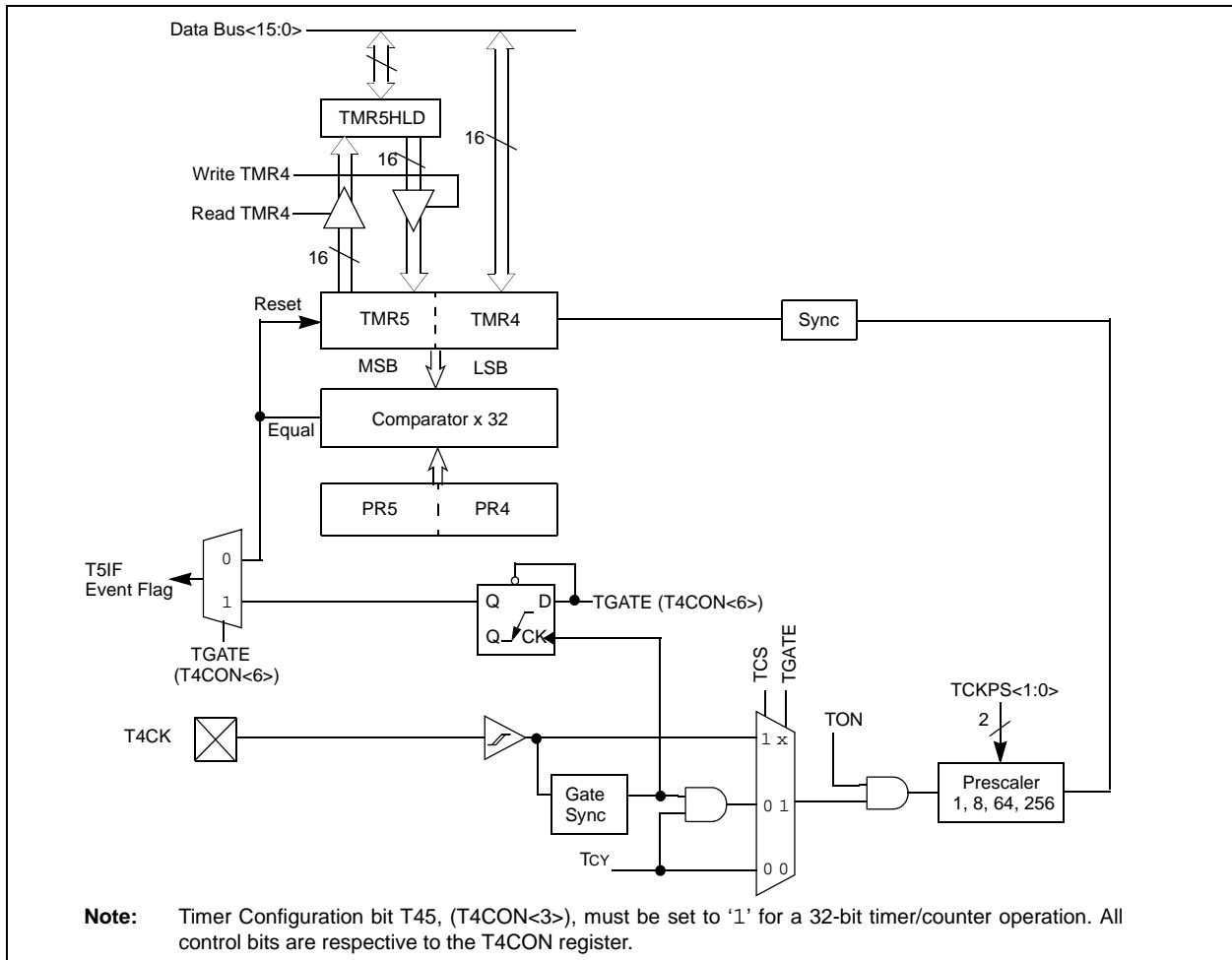

dsPIC30F5015/5016

FIGURE 11-2: 16-BIT TIMER4 BLOCK DIAGRAM (TYPE B TIMER)

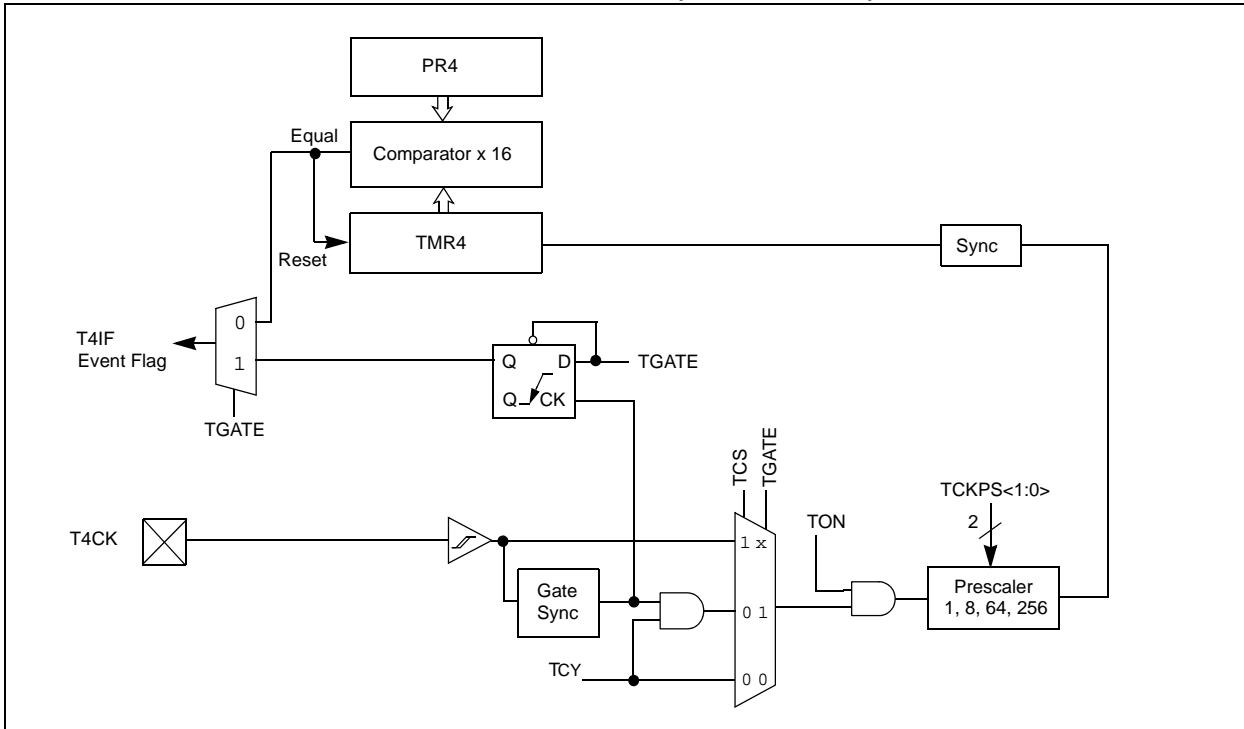

FIGURE 11-3: 16-BIT TIMER5 BLOCK DIAGRAM (TYPE C TIMER)

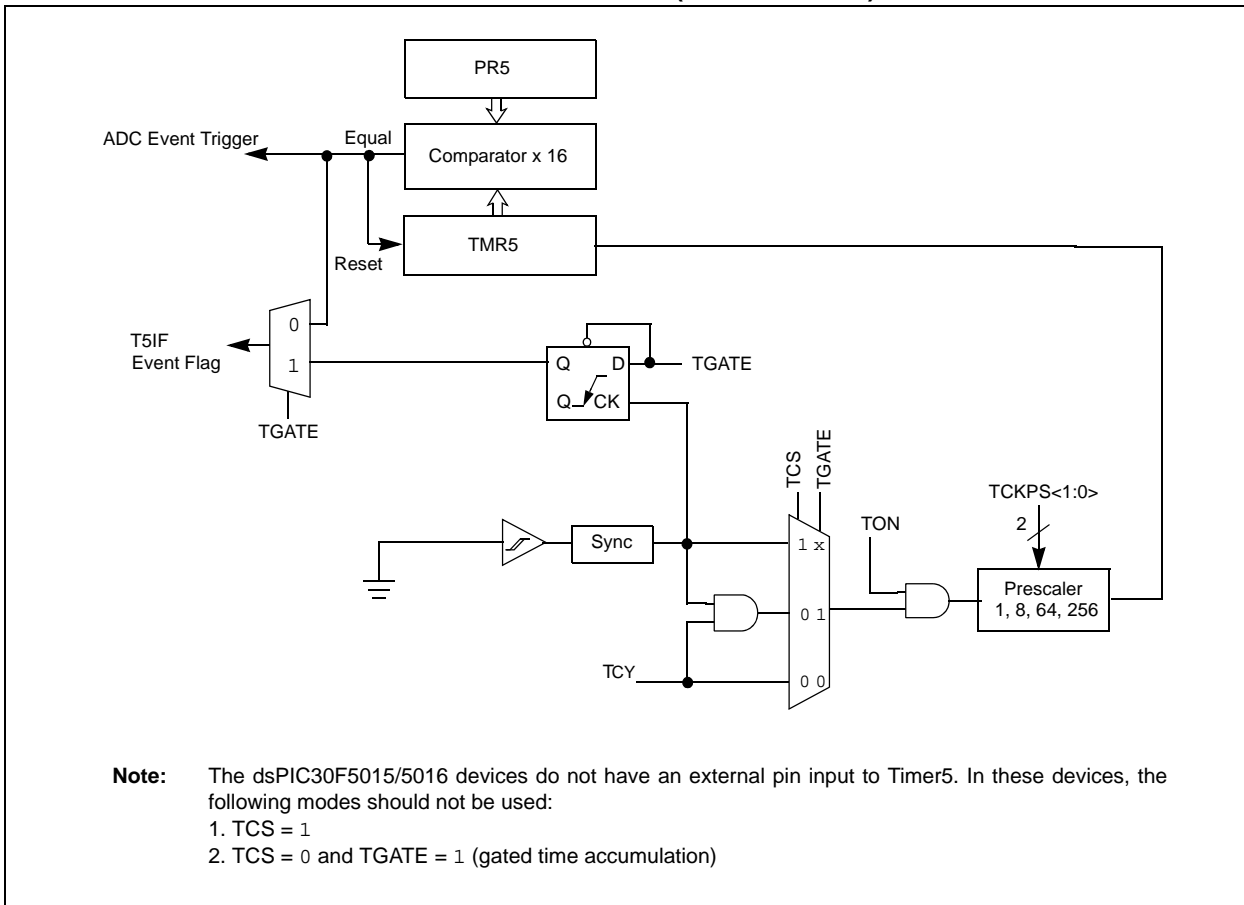

TABLE 11-1: TIMER4/5 REGISTER MAP⁽¹⁾

SFR Name	Addr.	Bit 15	Bit 14	Bit 13	Bit 12	Bit 11	Bit 10	Bit 9	Bit 8	Bit 7	Bit 6	Bit 5	Bit 4	Bit 3	Bit 2	Bit 1	Bit 0	Reset State
TMR4	0114	Timer4 Register																uuuu uuuu uuuu uuuu
TMR5HLD	0116	Timer5 Holding Register (For 32-bit operations only)																uuuu uuuu uuuu uuuu
TMR5	0118	Timer5 Register																uuuu uuuu uuuu uuuu
PR4	011A	Period Register 4																1111 1111 1111 1111
PR5	011C	Period Register 5																1111 1111 1111 1111
T4CON	011E	TON	—	TSIDL	—	—	—	—	—	—	TGATE	TCKPS1	TCKPS0	T45	—	TCS	—	0000 0000 0000 0000
T5CON	0120	TON	—	TSIDL	—	—	—	—	—	—	TGATE	TCKPS1	TCKPS0	—	—	—	—	0000 0000 0000 0000

Legend: u = uninitialized bit; — = unimplemented bit, read as '0'

Note 1: Refer to the “dsPIC30F Family Reference Manual” (DS70046) for descriptions of register bit fields.

dsPIC30F5015/5016

NOTES:

12.0 INPUT CAPTURE MODULE

Note: This data sheet summarizes features of this group of dsPIC30F devices and is not intended to be a complete reference source. For more information on the CPU, peripherals, register descriptions and general device functionality, refer to the “dsPIC30F Family Reference Manual” (DS70046). For more information on the device instruction set and programming, refer to the “16-bit MCU and DSC Programmer’s Reference Manual” (DS70157).

This section describes the input capture module and associated operational modes. The features provided by this module are useful in applications requiring frequency (period) and pulse measurement. Figure 12-1 depicts a block diagram of the input capture module. Input capture is useful for such modes as:

- Frequency/Period/Pulse Measurements
- Additional sources of External Interrupts

The key operational features of the input capture module are:

- Simple Capture Event mode
- Timer2 and Timer3 mode selection
- Interrupt on input capture event

These operating modes are determined by setting the appropriate bits in the ICxCON register (where $x = 1, 2, \dots, N$). The dsPIC30F5015/5016 device has eight capture channels.

12.1 Simple Capture Event Mode

The simple capture events in the dsPIC30F product family are:

- Capture every falling edge
- Capture every rising edge
- Capture every 4th rising edge
- Capture every 16th rising edge
- Capture every rising and falling edge

These simple Input Capture modes are configured by setting the appropriate bits ICM<2:0> (ICxCON<2:0>).

12.1.1 CAPTURE PRESCALER

There are four input capture prescaler settings, specified by bits ICM<2:0> (ICxCON<2:0>). Whenever the capture channel is turned off, the prescaler counter will be cleared. In addition, any Reset will clear the prescaler counter.

FIGURE 12-1: INPUT CAPTURE MODE BLOCK DIAGRAM

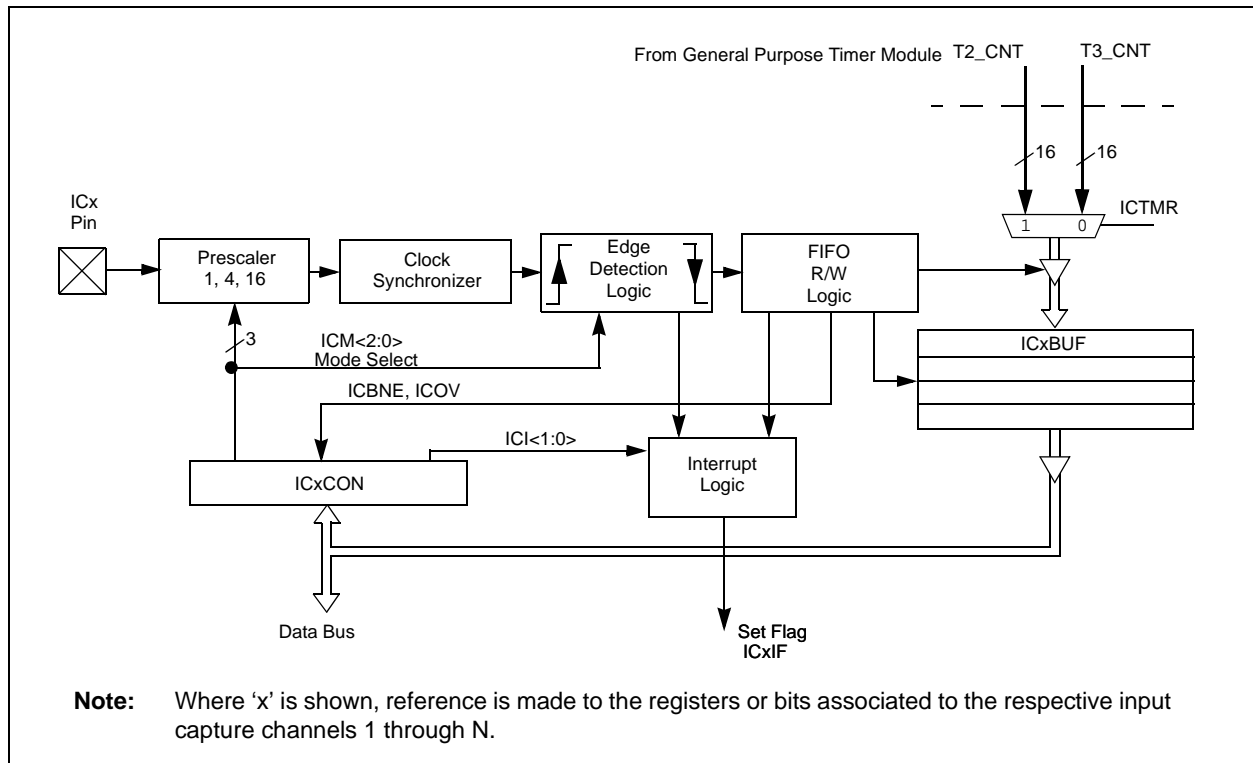

12.1.2 CAPTURE BUFFER OPERATION

Each capture channel has an associated FIFO buffer, which is four 16-bit words deep. There are two status flags, which provide status on the FIFO buffer:

- ICBFNE – Input Capture Buffer Not Empty
- ICOV – Input Capture Overflow

The ICBFNE will be set on the first input capture event and remain set until all capture events have been read from the FIFO. As each word is read from the FIFO, the remaining words are advanced by one position within the buffer.

In the event that the FIFO is full with four capture events and a fifth capture event occurs prior to a read of the FIFO, an overflow condition will occur and the ICOV bit will be set to a logic '1'. The fifth capture event is lost and is not stored in the FIFO. No additional events will be captured till all four events have been read from the buffer.

If a FIFO read is performed after the last read and no new capture event has been received, the read will yield indeterminate results.

12.1.3 TIMER2 AND TIMER3 SELECTION MODE

Each capture channel can select between one of two timers for the time base, Timer2 or Timer3.

Selection of the timer resource is accomplished through SFR bit ICTMR (ICxCON<7>). Timer3 is the default timer resource available for the input capture module.

12.1.4 HALL SENSOR MODE

When the input capture module is set for capture on every edge, rising and falling, ICM<2:0> = 001, the following operations are performed by the input capture logic:

- The input capture interrupt flag is set on every edge, rising and falling
- The interrupt on Capture mode setting bits, ICI<1:0>, is ignored, since every capture generates an interrupt
- A capture overflow condition is not generated in this mode

12.2 Input Capture Operation During Sleep and Idle Modes

An input capture event will generate a device wake-up or interrupt, if enabled, if the device is in CPU Idle or Sleep mode.

Independent of the timer being enabled, the input capture module will wake-up from the CPU Sleep or Idle mode when a capture event occurs, if ICM<2:0> = 111 and the interrupt enable bit is asserted. The same wake-up can generate an interrupt if the conditions for processing the interrupt have been satisfied. The wake-up feature is useful as a method of adding extra external pin interrupts.

12.2.1 INPUT CAPTURE IN CPU SLEEP MODE

CPU Sleep mode allows input capture module operation with reduced functionality. In the CPU Sleep mode, the ICI<1:0> bits are not applicable, and the input capture module can only function as an external interrupt source.

The capture module must be configured for interrupt only on the rising edge (ICM<2:0> = 111) in order for the input capture module to be used while the device is in Sleep mode. The prescale settings of 4:1 or 16:1 are not applicable in this mode.

12.2.2 INPUT CAPTURE IN CPU IDLE MODE

CPU Idle mode allows input capture module operation with full functionality. In the CPU Idle mode, the Interrupt mode selected by the ICI<1:0> bits is applicable, as well as the 4:1 and 16:1 capture prescale settings, which are defined by control bits ICM<2:0>. This mode requires the selected timer to be enabled. Moreover, the ICSIDL bit must be asserted to a logic '0'.

If the input capture module is defined as ICM<2:0> = 111 in CPU Idle mode, the input capture pin will serve only as an external interrupt pin.

12.3 Input Capture Interrupts

The input capture channels have the ability to generate an interrupt, based upon the selected number of capture events. The selection number is set by control bits ICI<1:0> (ICxCON<6:5>).

Each channel provides an interrupt flag bit (ICxIF). The respective capture channel interrupt flag is located in the corresponding IFSx Status register.

Enabling an interrupt is accomplished via the respective Capture Channel Interrupt Enable bit (ICxIE). The Capture Interrupt Enable bit is located in the corresponding IEC Control register.

TABLE 12-1: INPUT CAPTURE REGISTER MAP⁽¹⁾

SFR Name	Addr.	Bit 15	Bit 14	Bit 13	Bit 12	Bit 11	Bit 10	Bit 9	Bit 8	Bit 7	Bit 6	Bit 5	Bit 4	Bit 3	Bit 2	Bit 1	Bit 0	Reset State
IC1BUF	0140	Input 1 Capture Register																uuuu uuuu uuuu uuuu
IC1CON	0142	—	—	ICSIDL	—	—	—	—	—	ICTMR	ICI<1:0>	ICOV	ICBNE	ICM<2:0>			0000 0000 0000 0000	
IC2BUF	0144	Input 2 Capture Register																uuuu uuuu uuuu uuuu
IC2CON	0146	—	—	ICSIDL	—	—	—	—	—	ICTMR	ICI<1:0>	ICOV	ICBNE	ICM<2:0>			0000 0000 0000 0000	
IC3BUF	0148	Input 3 Capture Register																uuuu uuuu uuuu uuuu
IC3CON	014A	—	—	ICSIDL	—	—	—	—	—	ICTMR	ICI<1:0>	ICOV	ICBNE	ICM<2:0>			0000 0000 0000 0000	
IC4BUF	014C	Input 4 Capture Register																uuuu uuuu uuuu uuuu
IC4CON	014E	—	—	ICSIDL	—	—	—	—	—	ICTMR	ICI<1:0>	ICOV	ICBNE	ICM<2:0>			0000 0000 0000 0000	

Legend: u = uninitialized bit; — = unimplemented bit, read as '0'

Note 1: Refer to the "dsPIC30F Family Reference Manual" (DS70046) for descriptions of register bit fields.

dsPIC30F5015/5016

NOTES:

13.0 OUTPUT COMPARE MODULE

Note: This data sheet summarizes features of this group of dsPIC30F devices and is not intended to be a complete reference source. For more information on the CPU, peripherals, register descriptions and general device functionality, refer to the “dsPIC30F Family Reference Manual” (DS70046). For more information on the device instruction set and programming, refer to the “16-bit MCU and DSC Programmer’s Reference Manual” (DS70157).

This section describes the output compare module and associated operational modes. The features provided by this module are useful in applications requiring operational modes such as:

- Generation of Variable Width Output Pulses
- Power Factor Correction

Figure 13-1 depicts a block diagram of the output compare module.

The key operational features of the output compare module include:

- Timer2 and Timer3 Selection mode
- Simple Output Compare Match mode
- Dual Output Compare Match mode
- Simple PWM mode
- Output Compare during Sleep and Idle modes
- Interrupt on Output Compare/PWM Event

These operating modes are determined by setting the appropriate bits in the 16-bit OCxCON SFR (where $x = 1, 2, 3, \dots, N$). The dsPIC30F5015/5016 device has 4 compare channels.

OCxRS and OCxR in the figure represent the Dual Compare registers. In the Dual Compare mode, the OCxR register is used for the first compare and OCxRS is used for the second compare.

FIGURE 13-1: OUTPUT COMPARE MODE BLOCK DIAGRAM

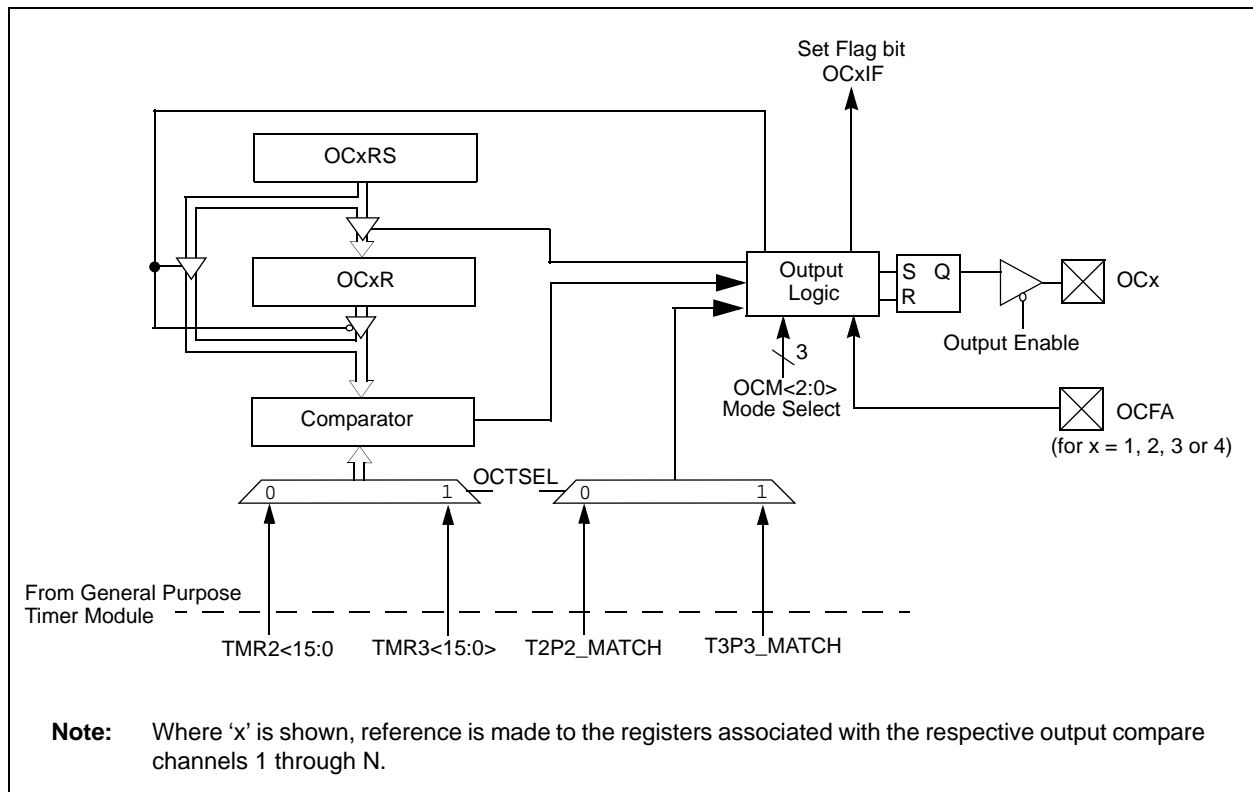

13.1 Timer2 and Timer3 Selection Mode

Each output compare channel can select between one of two 16-bit timers; Timer2 or Timer3.

The selection of the timers is controlled by the OCTSEL bit (OCxCON<3>). Timer2 is the default timer resource for the output compare module.

13.2 Simple Output Compare Match Mode

When control bits OCM<2:0> (OCxCON<2:0>) = 001, 010 or 011, the selected output compare channel is configured for one of three simple output compare match modes:

- Compare forces I/O pin low
- Compare forces I/O pin high
- Compare toggles I/O pin

The OCxR register is used in these modes. The OCxR register is loaded with a value and is compared to the selected incrementing timer count. When a compare occurs, one of these compare match modes occurs. If the counter resets to zero before reaching the value in OCxR, the state of the OCx pin remains unchanged.

13.3 Dual Output Compare Match Mode

When control bits OCM<2:0> (OCxCON<2:0>) = 100 or 101, the selected output compare channel is configured for one of two dual output compare modes, which are:

- Single Output Pulse mode
- Continuous Output Pulse mode

13.3.1 SINGLE-PULSE MODE

For the user to configure the module for the generation of a single output pulse, the following steps are required (assuming timer is off):

- Determine instruction cycle time T_{CY} .
- Calculate desired pulse width value based on T_{CY} .
- Calculate time to start pulse from timer start value of 0x0000.
- Write pulse width start and stop times into OCxR and OCxRS Compare registers (x denotes channel 1, 2, ...,N).
- Set Timer Period register to value equal to, or greater than, value in OCxRS Compare register.
- Set OCM<2:0> = 100.
- Enable timer, TON (TxCON<15>) = 1.

To initiate another single pulse, issue another write to set OCM<2:0> = 100.

13.3.2 CONTINUOUS PULSE MODE

For the user to configure the module for the generation of a continuous stream of output pulses, the following steps are required:

- Determine instruction cycle time T_{CY} .
- Calculate desired pulse value based on T_{CY} .
- Calculate timer to start pulse width from timer start value of 0x0000.
- Write pulse width start and stop times into OCxR and OCxRS (x denotes channel 1, 2, ...,N) Compare registers, respectively.
- Set Timer Period register to value equal to, or greater than, value in OCxRS Compare register.
- Set OCM<2:0> = 101.
- Enable timer, TON (TxCON<15>) = 1.

13.4 Simple PWM Mode

When control bits OCM<2:0> (OCxCON<2:0>) = 110 or 111, the selected output compare channel is configured for the PWM mode of operation. When configured for the PWM mode of operation, OCxR is the main latch (read-only) and OCxRS is the secondary latch. This enables glitchless PWM transitions.

The user must perform the following steps in order to configure the output compare module for PWM operation:

1. Set the PWM period by writing to the appropriate Period register.
2. Set the PWM duty cycle by writing to the OCxRS register.
3. Configure the output compare module for PWM operation.
4. Set the TMRx prescale value and enable the timer, TON (TxCON<15>) = 1.

13.4.1 INPUT PIN FAULT PROTECTION FOR PWM

When control bits OCM<2:0> (OCxCON<2:0>) = 111, the selected output compare channel is again configured for the PWM mode of operation, with the additional feature of input Fault protection. While in this mode, if a logic '0' is detected on the OCFA pin, the respective PWM output pin is placed in the high-impedance input state. The OCFLT bit (OCxCON<4>) indicates whether a Fault condition has occurred. This state will be maintained until both of the following events have occurred:

- The external Fault condition has been removed.
- The PWM mode has been re-enabled by writing to the appropriate control bits.

13.4.2 PWM PERIOD

The PWM period is specified by writing to the PRx register. The PWM period can be calculated using Equation 13-1.

EQUATION 13-1: PWM PERIOD

$$\text{PWM Period} = [(PRx) + 1] \cdot 4 \cdot T_{OSC} \cdot (\text{TMRx Prescale Value})$$

PWM frequency is defined as $1/[\text{PWM period}]$.

When the selected TMRx is equal to its respective Period register, PRx, the following four events occur on the next increment cycle:

- TMRx is cleared.
- The OCx pin is set.
 - Exception 1: If PWM duty cycle is 0x0000, the OCx pin will remain low.
 - Exception 2: If duty cycle is greater than PRx, the pin will remain high.
- The PWM duty cycle is latched from OCxRS into OCxR.
- The corresponding timer interrupt flag is set.

See Figure 13-1 for key PWM period comparisons. Timer3 is referred to in the figure for clarity.

FIGURE 13-1: PWM OUTPUT TIMING

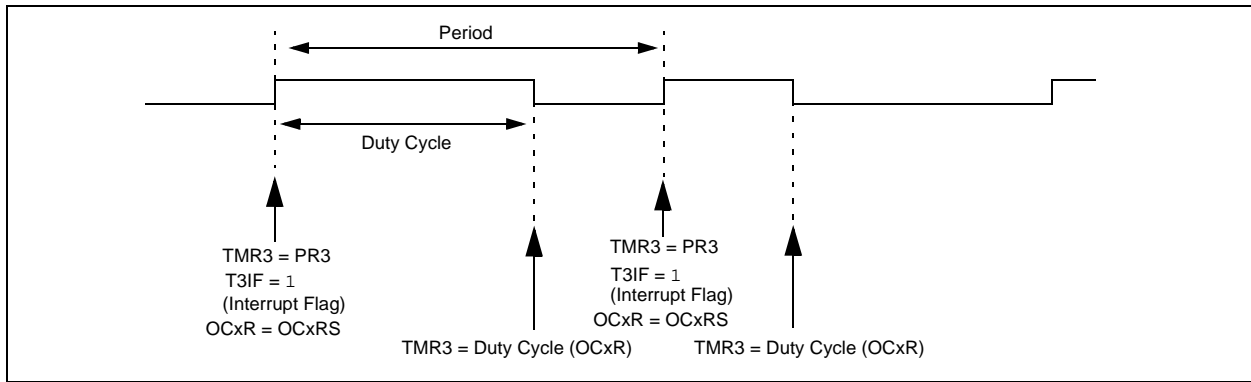

13.5 Output Compare Operation During CPU Sleep Mode

When the CPU enters the Sleep mode, all internal clocks are stopped. Therefore, when the CPU enters the Sleep state, the output compare channel will drive the pin to the active state that was observed prior to entering the CPU Sleep state.

For example, if the pin was high when the CPU entered the Sleep state, the pin will remain high. Likewise, if the pin was low when the CPU entered the Sleep state, the pin will remain low. In either case, the output compare module will resume operation when the device wakes up.

13.6 Output Compare Operation During CPU Idle Mode

When the CPU enters the Idle mode, the output compare module can operate with full functionality.

The output compare channel will operate during the CPU Idle mode if the OCSIDL bit (OCxCON<13>) is at logic '0' and the selected time base (Timer2 or Timer3) is enabled and the TSIDL bit of the selected timer is set to logic '0'.

13.7 Output Compare Interrupts

The output compare channels have the ability to generate an interrupt on a compare match, for whichever match mode has been selected.

For all modes except the PWM mode, when a compare event occurs, the respective interrupt flag (OCxIF) is asserted and an interrupt will be generated, if enabled. The OCxIF bit is located in the corresponding IFS Status register and must be cleared in software. The interrupt is enabled via the respective Compare Interrupt Enable bit (OCxIE), located in the corresponding IEC Control register.

For the PWM mode, when an event occurs, the respective Timer Interrupt Flag (T2IF or T3IF) is asserted and an interrupt will be generated, if enabled. The IF bit is located in the IFS0 Status register and must be cleared in software. The interrupt is enabled via the respective Timer Interrupt Enable bit (T2IE or T3IE), located in the IEC0 Control register. The output compare interrupt flag is never set during the PWM mode of operation.

TABLE 13-1: OUTPUT COMPARE REGISTER MAP⁽¹⁾

SFR Name	Addr.	Bit 15	Bit 14	Bit 13	Bit 12	Bit 11	Bit 10	Bit 9	Bit 8	Bit 7	Bit 6	Bit 5	Bit 4	Bit 3	Bit 2	Bit 1	Bit 0	Reset State
OC1RS	0180	Output Compare 1 Secondary Register																0000 0000 0000 0000
OC1R	0182	Output Compare 1 Main Register																0000 0000 0000 0000
OC1CON	0184	—	—	OCSIDL	—	—	—	—	—	—	—	—	OCFLT	OCTSEL	OCM<2:0>		0000 0000 0000 0000	
OC2RS	0186	Output Compare 2 Secondary Register																0000 0000 0000 0000
OC2R	0188	Output Compare 2 Main Register																0000 0000 0000 0000
OC2CON	018A	—	—	OCSIDL	—	—	—	—	—	—	—	—	OCFLT	OCTSE	OCM<2:0>		0000 0000 0000 0000	
OC3RS	018C	Output Compare 3 Secondary Register																0000 0000 0000 0000
OC3R	018E	Output Compare 3 Main Register																0000 0000 0000 0000
OC3CON	0190	—	—	OCSIDL	—	—	—	—	—	—	—	—	OCFLT	OCTSEL	OCM<2:0>		0000 0000 0000 0000	
OC4RS	0192	Output Compare 4 Secondary Register																0000 0000 0000 0000
OC4R	0194	Output Compare 4 Main Register																0000 0000 0000 0000
OC4CON	0196	—	—	OCSIDL	—	—	—	—	—	—	—	—	OCFLT	OCTSEL	OCM<2:0>		0000 0000 0000 0000	

Legend: — = unimplemented bit, read as '0'

Note 1: Refer to the "dsPIC30F Family Reference Manual" (DS70046) for descriptions of register bit fields.

dsPIC30F5015/5016

NOTES:

14.0 QUADRATURE ENCODER INTERFACE (QEI) MODULE

Note: This data sheet summarizes features of this group of dsPIC30F devices and is not intended to be a complete reference source. For more information on the CPU, peripherals, register descriptions and general device functionality, refer to the “dsPIC30F Family Reference Manual” (DS70046). For more information on the device instruction set and programming, refer to the “16-bit MCU and DSC Programmer’s Reference Manual” (DS70157).

This section describes the Quadrature Encoder Interface (QEI) module and associated operational modes. The QEI module provides the interface to incremental encoders for obtaining mechanical position data.

The operational features of the QEI include:

- Three input channels for two phase signals and index pulse
- 16-bit up/down position counter
- Count direction status
- Position Measurement (x2 and x4) mode
- Programmable digital noise filters on inputs
- Alternate 16-bit Timer/Counter mode
- Quadrature Encoder Interface interrupts

FIGURE 14-1: QUADRATURE ENCODER INTERFACE BLOCK DIAGRAM

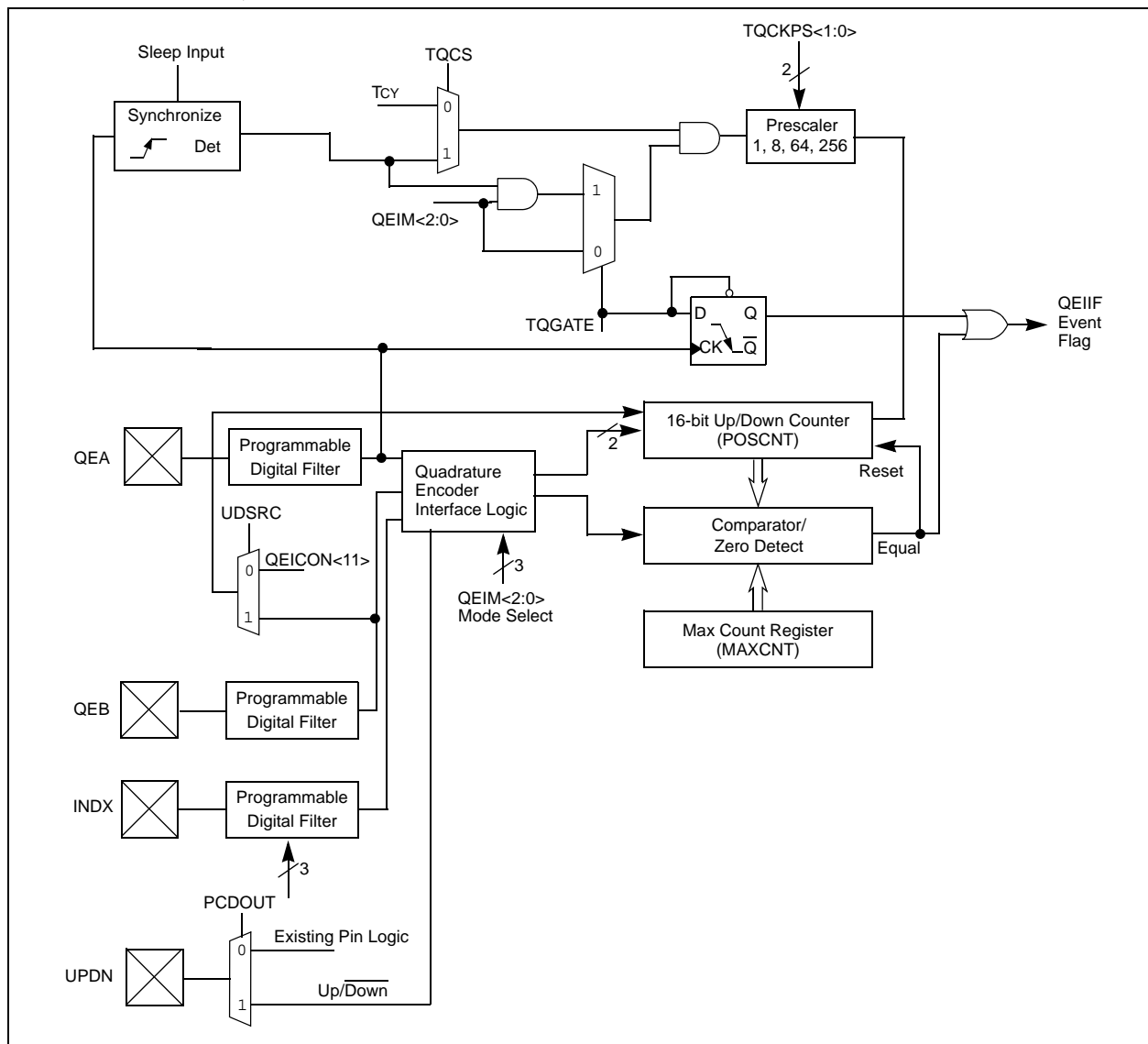

14.1 Quadrature Encoder Interface Logic

A typical incremental (a.k.a. optical) encoder has three outputs: Phase A, Phase B and an index pulse. These signals are useful and often required in position and speed control of ACIM and SR motors.

The two channels, Phase A (QEA) and Phase B (QEB), have a unique relationship. If Phase A leads Phase B, then the direction (of the motor) is deemed positive or forward. If Phase A lags Phase B, then the direction (of the motor) is deemed negative or reverse.

A third channel, termed index pulse, occurs once per revolution and is used as a reference to establish an absolute position. The index pulse coincides with Phase A and Phase B, both low.

14.2 16-bit Up/Down Position Counter Mode

The 16-bit up/down counter counts up or down on every count pulse, which is generated by the difference of the Phase A and Phase B input signals. The counter acts as an integrator, whose count value is proportional to position. The direction of the count is determined by the UPDN signal, which is generated by the Quadrature Encoder Interface logic.

14.2.1 POSITION COUNTER ERROR CHECKING

Position count error checking in the QEI is provided for and indicated by the CNTERR bit (QEICON<15>). The error checking only applies when the position counter is configured for Reset on the Index Pulse modes (QEIM<2:0> = 110 or 100). In these modes, the contents of the POSCNT register are compared with the values (0xFFFF or MAXCNT + 1, depending on direction). If these values are detected, an error condition is generated by setting the CNTERR bit and a QEI count error interrupt is generated. The QEI count error interrupt can be disabled by setting the CEID bit (DFLTCON<8>). The position counter continues to count encoder edges after an error has been detected. The POSCNT register continues to count up/down until a natural rollover/underflow. No interrupt is generated for the natural rollover/underflow event. The CNTERR bit is a read/write bit and reset in software by the user.

14.2.2 POSITION COUNTER RESET

The Position Counter Reset Enable bit, POSRES (QEICON<2>), controls whether the position counter is reset when the index pulse is detected. This bit is only applicable when QEIM<2:0> = 100 or 110.

If the POSRES bit is set to '1', then the position counter is reset when the index pulse is detected. If the POSRES bit is set to '0', then the position counter is not reset when the index pulse is detected. The position counter will continue counting up or down, and will be reset on the rollover or underflow condition.

The interrupt is still generated on the detection of the index pulse and not on the position counter overflow/underflow.

14.2.3 COUNT DIRECTION STATUS

As mentioned in the previous section, the QEI logic generates an UPDN signal, based upon the relationship between Phase A and Phase B. In addition to the output pin, the state of this internal UPDN signal is supplied to a SFR bit, UPDN (QEICON<11>), as a read-only bit. To place the state of this signal on an I/O pin, the SFR bit, PCDOUT (QEICON<6>), must be '1'.

14.3 Position Measurement Mode

There are two measurement modes which are supported and are termed x2 and x4. These modes are selected by the QEIM<2:0> mode select bits located in SFR QEICON<10:8>.

When control bits QEIM<2:0> = 100 or 101, the x2 Measurement mode is selected and the QEI logic only looks at the Phase A input for the position counter increment rate. Every rising and falling edge of the Phase A signal causes the position counter to be incremented or decremented. The Phase B signal is still utilized for the determination of the counter direction, just as in the x4 mode.

Within the x2 Measurement mode, there are two variations of how the position counter is reset:

1. Position counter reset by detection of index pulse, QEIM<2:0> = 100.
2. Position counter reset by match with MAXCNT, QEIM<2:0> = 101.

When control bits QEIM<2:0> = 110 or 111, the x4 Measurement mode is selected and the QEI logic looks at both edges of the Phase A and Phase B input signals. Every edge of both signals causes the position counter to increment or decrement.

Within the x4 Measurement mode, there are two variations of how the position counter is reset:

1. Position counter reset by detection of index pulse, QEIM<2:0> = 110.
2. Position counter reset by match with MAXCNT, QEIM<2:0> = 111.

The x4 Measurement mode provides for finer resolution data (more position counts) for determining motor position.

14.4 Programmable Digital Noise Filters

The digital noise filter section is responsible for rejecting noise on the incoming quadrature signals. Schmitt Trigger inputs and a three-clock cycle delay filter combine to reject low-level noise and large, short duration noise spikes that typically occur in noise prone applications, such as a motor system.

The filter ensures that the filtered output signal is not permitted to change until a stable value has been registered for three consecutive clock cycles.

For the QEA, QEB and INDX pins, the clock divide frequency for the digital filter is programmed by bits QECK<2:0> (DFLTCON<6:4>) and are derived from the base instruction cycle TCY.

To enable the filter output for channels QEA, QEB and INDX, the QEOUT bit must be '1'. The filter network for all channels is disabled on POR and BOR.

14.5 Alternate 16-bit Timer/Counter

When the QEI module is not configured for the QEI mode, QEIM<2:0> = 001, the module can be configured as a simple 16-bit timer/counter. The setup and control of the auxiliary timer is accomplished through the QEICON SFR register. This timer functions identically to Timer1. The QEA pin is used as the timer clock input.

When configured as a timer, the POSCNT register serves as the Timer Count register and the MAXCNT register serves as the Period register. When a Timer/Period register match occurs, the QEI interrupt flag will be asserted.

The only exception between the general purpose timers and this timer is the added feature of external up/down input select. When the UPDN pin is asserted high, the timer will increment up. When the UPDN pin is asserted low, the timer will be decremented.

Note: Changing the operational mode (i.e., from QEI to Timer or vice versa), will not affect the Timer/Position Count register contents.

The UPDN control/Status bit (QEICON<11>) can be used to select the count direction state of the Timer register. When UPDN = 1, the timer will count up. When UPDN = 0, the timer will count down.

In addition, control bit, UDSRC (QEICON<0>), determines whether the timer count direction state is based on the logic state written into the UPDN control/Status bit (QEICON<11>), or the QEB pin state. When

UDSRC = 1, the timer count direction is controlled from the QEB pin. Likewise, when UDSRC = 0, the timer count direction is controlled by the UPDN bit.

Note: This timer does not support the External Asynchronous Counter mode of operation. If using an external clock source, the clock will automatically be synchronized to the internal instruction cycle.

14.6 QEI Module Operation During CPU Sleep Mode

14.6.1 QEI OPERATION DURING CPU SLEEP MODE

The QEI module will be halted during the CPU Sleep mode.

14.6.2 TIMER OPERATION DURING CPU SLEEP MODE

During CPU Sleep mode, the timer will not operate, because the internal clocks are disabled.

14.7 QEI Module Operation During CPU Idle Mode

Since the QEI module can function as a Quadrature Encoder Interface, or as a 16-bit timer, the following section describes operation of the module in both modes.

14.7.1 QEI OPERATION DURING CPU IDLE MODE

When the CPU is placed in the Idle mode, the QEI module will operate if the QEISIDL bit (QEICON<13>) = 0. This bit defaults to a logic '0' upon executing POR and BOR. For halting the QEI module during the CPU Idle mode, QEISIDL should be set to '1'.

14.7.2 TIMER OPERATION DURING CPU IDLE MODE

When the CPU is placed in the Idle mode and the QEI module is configured in the 16-bit Timer mode, the 16-bit timer will operate if the QEISIDL bit (QEICON<13>) = 0. This bit defaults to a logic '0' upon executing POR and BOR. For halting the timer module during the CPU Idle mode, QEISIDL should be set to '1'.

If the QEISIDL bit is cleared, the timer will function normally, as if the CPU Idle mode had not been entered.

14.8 Quadrature Encoder Interface Interrupts

The Quadrature Encoder Interface has the ability to generate an interrupt on occurrence of the following events:

- Interrupt on 16-bit up/down position counter rollover/underflow
- Detection of qualified index pulse, or if CNTERR bit is set
- Timer period match event (overflow/underflow)
- Gate accumulation event

The QEI Interrupt Flag bit, QEIIF, is asserted upon occurrence of any of the above events. The QEIIF bit must be cleared in software. QEIIF is located in the IFS2 Status register.

Enabling an interrupt is accomplished via the respective enable bit, QEIIE. The QEIIE bit is located in the IEC2 Control register.

TABLE 14-1: QEI REGISTER MAP⁽¹⁾

SFR Name	Addr.	Bit 15	Bit 14	Bit 13	Bit 12	Bit 11	Bit 10	Bit 9	Bit 8	Bit 7	Bit 6	Bit 5	Bit 4	Bit 3	Bit 2	Bit 1	Bit 0	Reset State
QEICON	0122	CNTERR	—	QEISIDL	INDX	UPDN	QEIM<2:0>		SWPAB	PCDOU	TQGATE	TQCKPS<1:0>		POSRES	TQCS	UDSRC	0000 0000 0000 0000	
DFLTCON	0124	—	—	—	—	—	IMV<1:0>	CEID	QEOUT	QECK2	QECK1	QECK0	—	—	—	—	0000 0000 0000 0000	
POSCNT	0126	Position Counter<15:0>															0000 0000 0000 0000	
MAXCNT	0128	Maximun Count<15:0>															1111 1111 1111 1111	

Legend: — = unimplemented bit, read as '0'

Note 1: Refer to the "dsPIC30F Family Reference Manual" (DS70046) for descriptions of register bit fields.

dsPIC30F5015/5016

NOTES:

15.0 MOTOR CONTROL PWM MODULE

Note: This data sheet summarizes features of this group of dsPIC30F devices and is not intended to be a complete reference source. For more information on the CPU, peripherals, register descriptions and general device functionality, refer to the “*dsPIC30F Family Reference Manual*” (DS70046). For more information on the device instruction set and programming, refer to the “*16-bit MCU and DSC Programmer’s Reference Manual*” (DS70157).

This module simplifies the task of generating multiple, synchronized Pulse-Width Modulated (PWM) outputs. In particular, the following power and motion control applications are supported by the PWM module:

- Three Phase AC Induction Motor
- Switched Reluctance (SR) Motor
- Brushless DC (BLDC) Motor
- Uninterruptible Power Supply (UPS)

The PWM module has the following features:

- Eight PWM I/O pins with four duty cycle generators
- Up to 16-bit resolution
- ‘On-the-Fly’ PWM frequency changes
- Edge and Center-Aligned Output modes
- Single-Pulse Generation mode
- Interrupt support for asymmetrical updates in Center-Aligned mode
- Output override control for Electrically Commutative Motor (ECM) operation
- ‘Special Event’ comparator for scheduling other peripheral events
- Fault pins to optionally drive each of the PWM output pins to a defined state
- Duty cycle updates are configurable to be immediate or synchronized to the PWM time base

This module contains four duty cycle generators, numbered 1 through 4. The module has eight PWM output pins, numbered PWM1H/PWM1L through PWM4H/PWM4L. The eight I/O pins are grouped into high/low numbered pairs, denoted by the suffix H or L, respectively. For complementary loads, the low PWM pins are always the complement of the corresponding high I/O pin.

The PWM module allows several modes of operation which are beneficial for specific power control applications.

dsPIC30F5015/5016

FIGURE 15-1: PWM MODULE BLOCK DIAGRAM

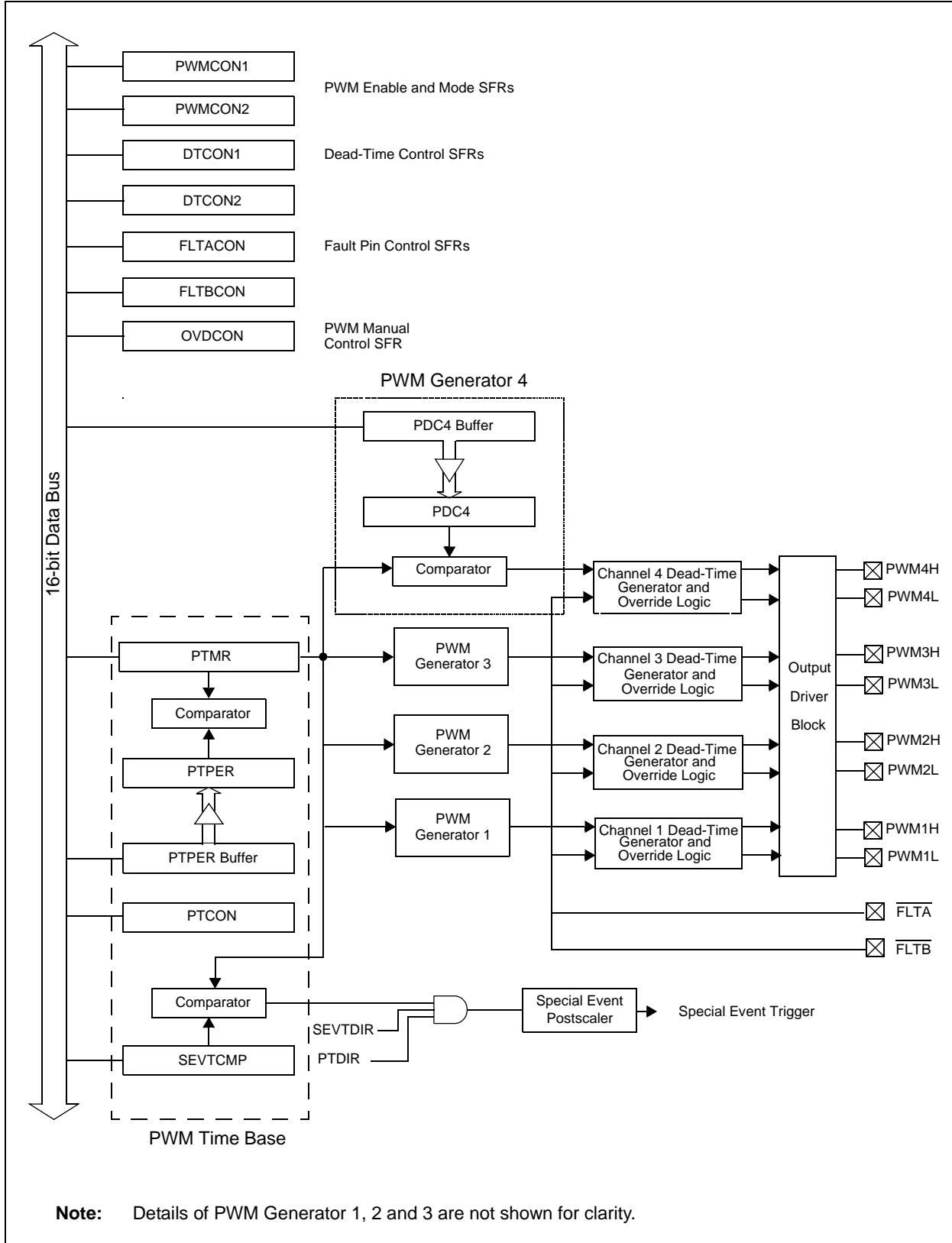

15.1 PWM Time Base

The PWM time base is provided by a 15-bit timer with a prescaler and postscaler. The time base is accessible via the PTMR SFR. PTMR<15> is a read-only Status bit, PTDIR, that indicates the present count direction of the PWM time base. If PTDIR is cleared, PTMR is counting upwards. If PTDIR is set, PTMR is counting downwards. The PWM time base is configured via the PTCAN SFR. The time base is enabled/disabled by setting/clearing the PTEN bit in the PTCAN SFR. PTMR is not cleared when the PTEN bit is cleared in software.

The PTPER SFR sets the counting period for PTMR. The user must write a 15-bit value to PTPER<14:0>. When the value in PTMR<14:0> matches the value in PTPER<14:0>, the time base will either reset to '0', or reverse the count direction on the next occurring clock cycle. The action taken depends on the operating mode of the time base.

Note: If the Period register is set to 0x0000, the timer will stop counting, and the interrupt and the special event trigger will not be generated, even if the special event value is also 0x0000. The module will not update the Period register if it is already at 0x0000; therefore, the user must disable the module in order to update the Period register.

The PWM time base can be configured for four different modes of operation:

- Free-Running mode
- Single-Shot mode
- Continuous Up/Down Count mode
- Continuous Up/Down Count mode with interrupts for double updates

These four modes are selected by the PTMOD<1:0> bits in the PTCAN SFR. The Up/Down Counting modes support center-aligned PWM generation. The Single-Shot mode allows the PWM module to support pulse control of certain Electronically Commutative Motors (ECMs).

The interrupt signals generated by the PWM time base depend on the mode selection bits (PTMOD<1:0>) and the postscaler bits (PTOPS<3:0>) in the PTCAN SFR.

15.1.1 FREE-RUNNING MODE

In Free-Running mode, the PWM time base counts upwards until the value in the Time Base Period register (PTPER) is matched. The PTMR register is reset on the following input clock edge and the time base will continue to count upwards as long as the PTEN bit remains set.

When the PWM time base is in the Free-Running mode (PTMOD<1:0> = 00), an interrupt event is generated each time a match with the PTPER register occurs and the PTMR register is reset to zero. The postscaler selection bits may be used in this mode of the timer to reduce the frequency of the interrupt events.

15.1.2 SINGLE-SHOT MODE

In the Single-Shot Counting mode, the PWM time base begins counting upwards when the PTEN bit is set. When the value in the PTMR register matches the PTPER register, the PTMR register will be reset on the following input clock edge and the PTEN bit will be cleared by the hardware to halt the time base.

When the PWM time base is in the Single-Shot mode (PTMOD<1:0> = 01), an interrupt event is generated when a match with the PTPER register occurs, the PTMR register is reset to zero on the following input clock edge, and the PTEN bit is cleared. The postscaler selection bits have no effect in this mode of the timer.

15.1.3 CONTINUOUS UP/DOWN COUNTING MODES

In the Continuous Up/Down Counting modes, the PWM time base counts upwards until the value in the PTPER register is matched. The timer will begin counting downwards on the following input clock edge. The PTDIR bit in the PTCAN SFR is read-only and indicates the counting direction. The PTDIR bit is set when the timer counts downwards.

In the Up/Down Counting mode (PTMOD<1:0> = 10), an interrupt event is generated each time the value of the PTMR register becomes zero and the PWM time base begins to count upwards. The postscaler selection bits may be used in this mode of the timer to reduce the frequency of the interrupt events.

dsPIC30F5015/5016

15.1.4 DOUBLE UPDATE MODE

In the Double Update mode (PTMOD<1:0> = 11), an interrupt event is generated each time the PTMR register is equal to zero, as well as each time a period match occurs. The postscaler selection bits have no effect in this mode of the timer.

The Double Update mode provides two additional functions to the user. First, the control loop bandwidth is doubled because the PWM duty cycles can be updated, twice per period. Second, asymmetrical center-aligned PWM waveforms can be generated, which are useful for minimizing output waveform distortion in certain motor control applications.

Note: Programming a value of 0x0001 in the Period register could generate a continuous interrupt pulse and hence, must be avoided.

15.1.5 PWM TIME BASE PRESCALER

The input clock to PTMR (Fosc/4), has prescaler options of 1:1, 1:4, 1:16, or 1:64, selected by control bits PTCKPS<1:0> in the PTCN SFR. The prescaler counter is cleared when any of the following occurs:

- a write to the PTMR register
- a write to the PTCN register
- any device Reset

PTMR is not cleared when PTCN is written.

15.1.6 PWM TIME BASE POSTSCALER

The match output of PTMR can optionally be post-scaled through a 4-bit postscaler (which gives a 1:1 to 1:16 scaling).

The postscaler counter is cleared when any of the following occurs:

- a write to the PTMR register
- a write to the PTCN register
- any device Reset

The PTMR register is not cleared when PTCN is written.

15.2 PWM Period

PTPER is a 15-bit register and is used to set the counting period for the PWM time base. PTPER is a double-buffered register. The PTPER buffer contents are loaded into the PTPER register at the following instants:

- Free-Running and Single-Shot modes: When the PTMR register is reset to zero after a match with the PTPER register.
- Up/Down Counting modes: When the PTMR register is zero.

The value held in the PTPER buffer is automatically loaded into the PTPER register when the PWM time base is disabled (PTEN = 0).

The PWM period can be determined using [Equation 15-1](#):

EQUATION 15-1: PWM PERIOD

$$T_{PWM} = T_{CY} \cdot (PTPER + 1) \cdot \text{PTMR Prescale Value}$$

If the PWM time base is configured for one of the Up/Down Count modes, the PWM period is given by [Equation 15-2](#).

EQUATION 15-2: PWM PERIOD (UP/DOWN MODE)

$$T_{PWM} = T_{CY} \cdot 2 \cdot (PTPER + 1) \cdot \text{PTMR Prescale Value}$$

The maximum resolution (in bits) for a given device oscillator and PWM frequency can be determined using [Equation 15-3](#):

EQUATION 15-3: PWM RESOLUTION

$$\text{Resolution} = \frac{\log(2 \cdot T_{PWM}/T_{CY})}{\log(2)}$$

15.3 Edge-Aligned PWM

Edge-aligned PWM signals are produced by the module when the PWM time base is in the Free-Running or Single-Shot mode. For edge-aligned PWM outputs, the output has a period specified by the value in PTPER and a duty cycle specified by the appropriate Duty Cycle register (see [Figure 15-2](#)). The PWM output is driven active at the beginning of the period (PTMR = 0) and is driven inactive when the value in the Duty Cycle register matches PTMR.

If the value in a particular Duty Cycle register is zero, then the output on the corresponding PWM pin will be inactive for the entire PWM period. In addition, the output on the PWM pin will be active for the entire PWM period if the value in the Duty Cycle register is greater than the value held in the PTPER register.

FIGURE 15-2: EDGE-ALIGNED PWM

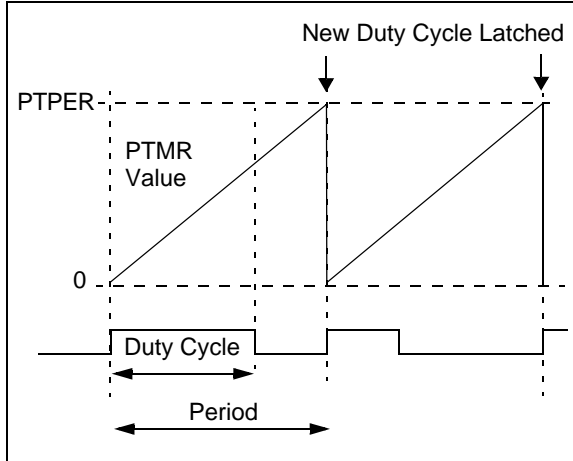

15.4 Center-Aligned PWM

Center-aligned PWM signals are produced by the module when the PWM time base is configured in an Up/Down Counting mode (see [Figure 15-3](#)).

The PWM compare output is driven to the active state when the value of the Duty Cycle register matches the value of PTMR and the PWM time base is counting downwards (PTDIR = 1). The PWM compare output is driven to the inactive state when the PWM time base is counting upwards (PTDIR = 0) and the value in the PTMR register matches the duty cycle value.

If the value in a particular Duty Cycle register is zero, then the output on the corresponding PWM pin will be inactive for the entire PWM period. In addition, the output on the PWM pin will be active for the entire PWM period if the value in the Duty Cycle register is equal to the value held in the PTPER register.

FIGURE 15-3: CENTER-ALIGNED PWM

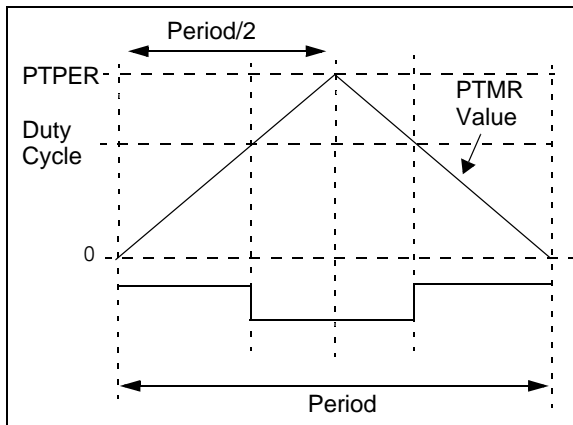

15.5 PWM Duty Cycle Comparison Units

There are four 16-bit Special Function Registers (PDC1, PDC2, PDC3 and PDC4) used to specify duty cycle values for the PWM module.

The value in each Duty Cycle register determines the amount of time that the PWM output is in the active state. The Duty Cycle registers are 16 bits wide. The LSB of a Duty Cycle register determines whether the PWM edge occurs in the beginning. Thus, the PWM resolution is effectively doubled.

15.5.1 DUTY CYCLE REGISTER BUFFERS

The four PWM Duty Cycle registers are double-buffered to allow glitchless updates of the PWM outputs. For each duty cycle, there is a Duty Cycle register that is accessible by the user, and a second Duty Cycle register that holds the actual compare value used in the present PWM period.

For edge-aligned PWM output, a new duty cycle value will be updated whenever a match with the PTPER register occurs and PTMR is reset. The contents of the duty cycle buffers are automatically loaded into the Duty Cycle registers when the PWM time base is disabled (PTEN = 0) and the UDIS bit is cleared in PWMCON2.

When the PWM time base is in the Up/Down Counting mode, new duty cycle values are updated when the value of the PTMR register is zero and the PWM time base begins to count upwards. The contents of the duty cycle buffers are automatically loaded into the Duty Cycle registers when the PWM time base is disabled (PTEN = 0).

When the PWM time base is in the Up/Down Counting mode with double updates, new duty cycle values are updated when the value of the PTMR register is zero, and when the value of the PTMR register matches the value in the PTPER register. The contents of the duty cycle buffers are automatically loaded into the Duty Cycle registers when the PWM time base is disabled (PTEN = 0).

15.5.2 DUTY CYCLE IMMEDIATE UPDATES

When the Immediate Update Enable bit is set (IUE = 1), any write to the Duty Cycle registers updates the new duty cycle value immediately. This feature gives the option to the user to allow immediate updates of the active PWM Duty Cycle registers instead of waiting for the end of the current time base period. System stability is improved in closed-loop servo applications by reducing the delay between system observation and the issuance of system corrective commands when immediate updates are enabled.

If the PWM output is active at the time the new duty cycle is written, and the new duty cycle is less than the current time base value, the PWM pulse width is shortened.

If the PWM output is active at the time the new duty cycle is written, and the new duty cycle is greater than the current time base value, the PWM pulse width is lengthened.

If the PWM output is inactive at the time the new duty cycle is written, and the new duty cycle is greater than the current time base value, the PWM output becomes active immediately and remains active for the new written duty cycle value.

15.6 Complementary PWM Operation

In the Complementary mode of operation, each pair of PWM outputs is obtained by a complementary PWM signal. A dead time may be optionally inserted during device switching, when both outputs are inactive for a short period (Refer to [Section 15.7 “Dead-Time Generators”](#)).

In Complementary mode, the duty cycle comparison units are assigned to the PWM outputs as follows:

- PDC1 register controls PWM1H/PWM1L outputs
- PDC2 register controls PWM2H/PWM2L outputs
- PDC3 register controls PWM3H/PWM3L outputs
- PDC4 register controls PWM4H/PWM4L outputs

The Complementary mode is selected for each PWM I/O pin pair by clearing the appropriate PMODx bit in the PWMCON1 SFR. The PWM I/O pins are set to Complementary mode by default upon a device Reset.

15.7 Dead-Time Generators

Dead-time generation may be provided when any of the PWM I/O pin pairs are operating in the Complementary Output mode. The PWM outputs use Push-Pull drive circuits. Due to the inability of the power output devices to switch instantaneously, some amount of time must be provided between the turn off event of one PWM output in a complementary pair and the turn on event of the other transistor.

The PWM module allows two different dead times to be programmed. These two dead times may be used in one of two methods described below to increase user flexibility:

- The PWM output signals can be optimized for different turn off times in the high side and low side transistors in a complementary pair of transistors. The first dead time is inserted between the turn off event of the lower transistor of the complementary pair and the turn on event of the upper transistor. The second dead time is inserted between the turn off event of the upper transistor and the turn on event of the lower transistor.
- The two dead times can be assigned to individual PWM I/O pin pairs. This operating mode allows the PWM module to drive different transistor/load combinations with each complementary PWM I/O pin pair.

15.7.1 DEAD-TIME GENERATORS

Each complementary output pair for the PWM module has a 6-bit down counter that is used to produce the dead-time insertion. As shown in [Figure 15-4](#), each dead-time unit has a rising and falling edge detector connected to the duty cycle comparison output.

15.7.2 DEAD-TIME ASSIGNMENT

The DTCON2 SFR contains control bits that allow the dead times to be assigned to each of the complementary outputs. Table 15-1 summarizes the function of each dead-time selection control bit.

TABLE 15-1: DEAD-TIME SELECTION BITS

Bit	Selects
DTS1A	PWM1L/PWM1H active edge dead time.
DTS1I	PWM1L/PWM1H inactive edge dead time.
DTS2A	PWM2L/PWM2H active edge dead time.
DTS2I	PWM2L/PWM2H inactive edge dead time.
DTS3A	PWM3L/PWM3H active edge dead time.
DTS3I	PWM3L/PWM3H inactive edge dead time.
DTS4A	PWM4L/PWM4H active edge dead time.
DTS4I	PWM4L/PWM4H inactive edge dead time.

15.7.3 DEAD-TIME RANGES

The amount of dead time provided by each dead-time unit is selected by specifying the input clock prescaler value and a 6-bit unsigned value. The amount of dead time provided by each unit may be set independently.

Four input clock prescaler selections have been provided to allow a suitable range of dead times, based on the device operating frequency. The clock prescaler option may be selected independently for each of the two dead-time values. The dead-time clock prescaler values are selected using the DTAPS<1:0> and DTBPS<1:0> control bits in the DTCON1 SFR. One of four clock prescaler options (T_{CY} , $2 T_{CY}$, $4 T_{CY}$ or $8 T_{CY}$) may be selected for each of the dead-time values.

After the prescaler values are selected, the dead time for each unit is adjusted by loading two 6-bit unsigned values into the DTCON1 SFR.

The dead-time unit prescalers are cleared on the following events:

- On a load of the down timer due to a duty cycle comparison edge event.
- On a write to the DTCON1 or DTCON2 registers.
- On any device Reset.

Note: The user should not modify the DTCON1 or DTCON2 values while the PWM module is operating ($PTEN = 1$). Unexpected results may occur.

FIGURE 15-4: DEAD-TIME TIMING DIAGRAM

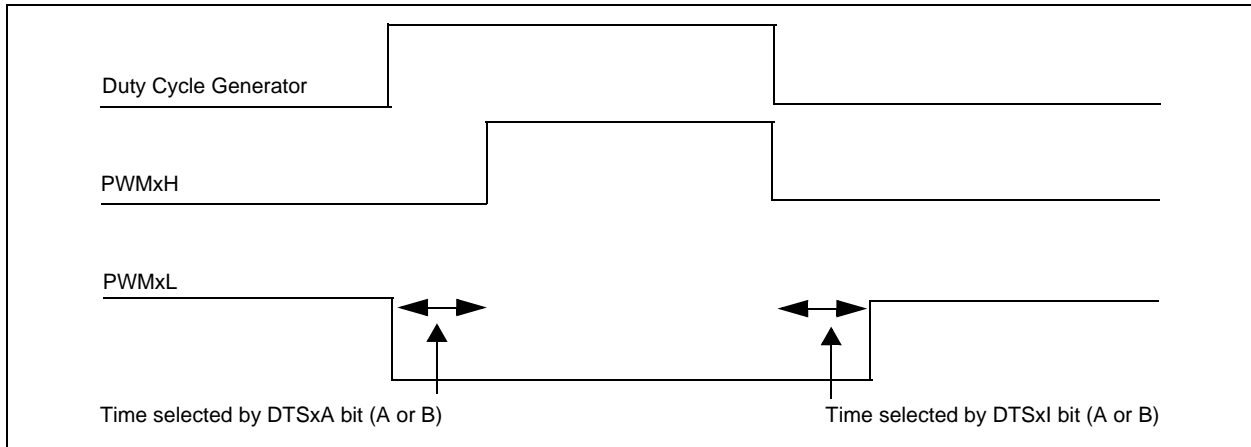

15.8 Independent PWM Output

An Independent PWM Output mode is required for driving certain types of loads. A particular PWM output pair is in the Independent Output mode when the corresponding PMOD bit in the PWMCON1 register is set. No dead-time control is implemented between adjacent PWM I/O pins when the module is operating in the Independent mode and both I/O pins are allowed to be active simultaneously.

In the Independent mode, each duty cycle generator is connected to both of the PWM I/O pins in an output pair. By using the associated Duty Cycle register and the appropriate bits in the OVDCON register, the user may select the following signal output options for each PWM I/O pin operating in the Independent mode:

- I/O pin outputs PWM signal
- I/O pin inactive
- I/O pin active

15.9 Single-Pulse PWM Operation

The PWM module produces single-pulse outputs when the PTCON control bits PTMOD<1:0> = 10. Only edge-aligned outputs may be produced in the Single-Pulse mode. In Single-Pulse mode, the PWM I/O pin(s) are driven to the active state when the PTEN bit is set. When a match with a Duty Cycle register occurs, the PWM I/O pin is driven to the inactive state. When a match with the PTPER register occurs, the PTMR register is cleared, all active PWM I/O pins are driven to the inactive state, the PTEN bit is cleared and an interrupt is generated.

15.10 PWM Output Override

The PWM output override bits allow the user to manually drive the PWM I/O pins to specified logic states, independent of the duty cycle comparison units.

All control bits associated with the PWM output override function are contained in the OVDCON register. The upper half of the OVDCON register contains eight bits, POVDxH<4:1> and POVDxL<4:1>, that determine which PWM I/O pins will be overridden. The lower half of the OVDCON register contains eight bits, POUTxH<4:1> and POUTxL<4:1>, that determine the state of the PWM I/O pins when a particular output is overridden via the POVD bits.

15.10.1 COMPLEMENTARY OUTPUT MODE

When a PWMxL pin is driven active via the OVDCON register, the output signal is forced to be the complement of the corresponding PWMxH pin in the pair. Dead-time insertion is still performed when PWM channels are overridden manually.

15.10.2 OVERRIDE SYNCHRONIZATION

If the OSYNC bit in the PWMCON2 register is set, all output overrides performed via the OVDCON register are synchronized to the PWM time base. Synchronous output overrides occur at the following times:

- Edge-Aligned mode, when PTMR is zero.
- Center-Aligned modes, when PTMR is zero and when the value of PTMR matches PTPER.

15.11 PWM Output and Polarity Control

There are three device Configuration bits associated with the PWM module that provide PWM output pin control:

- HPOL Configuration bit
- LPOL Configuration bit
- PWMPIN Configuration bit

These three bits in the FBORPOR Configuration register (see [Section 21.6 “Device Configuration Registers”](#)) work in conjunction with the four PWM Enable bits (PWMEN<4:1>) located in the PWMCON1 SFR. The Configuration bits and PWM enable bits ensure that the PWM pins are in the correct states after a device Reset occurs. The PWMPIN configuration fuse allows the PWM module outputs to be optionally enabled on a device Reset. If PWMPIN = 0, the PWM outputs will be driven to their inactive states at Reset. If PWMPIN = 1 (default), the PWM outputs will be tri-stated. The HPOL bit specifies the polarity for the PWMxH outputs, whereas the LPOL bit specifies the polarity for the PWMxL outputs.

15.11.1 OUTPUT PIN CONTROL

The PENxH and PENxL control bits in the PWMCON1 SFR enable each high PWM output pin and each low PWM output pin, respectively. If a particular PWM output pin is not enabled, it is treated as a general purpose I/O pin.

15.12 PWM FAULT Pins

There are two Fault pins (\overline{FLTA} and $\overline{FLT B}$) associated with the PWM module. When asserted, these pins can optionally drive each of the PWM I/O pins to a defined state.

15.12.1 FAULT PIN ENABLE BITS

The FLTACON and FLTBCON SFRs each have 4 control bits that determine whether a particular pair of PWM I/O pins is to be controlled by the Fault input pin. To enable a specific PWM I/O pin pair for Fault overrides, the corresponding bit should be set in the FLTACON or FLTBCON register.

If all enable bits are cleared in the FLTACON or FLTBCON registers, then the corresponding Fault input pin has no effect on the PWM module and the pin may be used as a general purpose interrupt or I/O pin.

Note: The Fault pin logic can operate independent of the PWM logic. If all the enable bits in the FLTACON/FLTBCON registers are cleared, then the Fault pin(s) could be used as general purpose interrupt pin(s). Each Fault pin has an interrupt vector, interrupt flag bit and interrupt priority bits associated with it.

15.12.2 FAULT STATES

The FLTACON and FLTBCON Special Function Registers have 8 bits each that determine the state of each PWM I/O pin when it is overridden by a Fault input. When these bits are cleared, the PWM I/O pin is driven to the inactive state. If the bit is set, the PWM I/O pin will be driven to the active state. The active and inactive states are referenced to the polarity defined for each PWM I/O pin (HPOL and LPOL polarity control bits).

A special case exists when a PWM module I/O pair is in the Complementary mode and both pins are programmed to be active on a Fault condition. The PWMxH pin always has priority in the Complementary mode, so that both I/O pins cannot be driven active simultaneously.

15.12.3 FAULT PIN PRIORITY

If both Fault input pins have been assigned to control a particular PWM I/O pin, the Fault state programmed for the Fault A input pin will take priority over the Fault B input pin.

15.12.4 FAULT INPUT MODES

Each of the Fault input pins has two modes of operation:

- **Latched Mode:** When the Fault pin is driven low, the PWM outputs will go to the states defined in the FLTACON/FLTBCON register. The PWM outputs will remain in this state until the Fault pin is driven high and the corresponding interrupt flag has been cleared in software. When both of these actions have occurred, the PWM outputs will return to normal operation at the beginning of the next PWM cycle or half-cycle boundary. If the interrupt flag is cleared before the Fault condition ends, the PWM module will wait until the Fault pin is no longer asserted, to restore the outputs.
- **Cycle-by-Cycle Mode:** When the Fault input pin is driven low, the PWM outputs remain in the defined Fault states for as long as the Fault pin is held low. After the Fault pin is driven high, the PWM outputs return to normal operation at the beginning of the following PWM cycle or half-cycle boundary.

The operating mode for each Fault input pin is selected using the FLTAM and FLTBM control bits in the FLTACON and FLTBCON Special Function Registers.

Each of the Fault pins can be controlled manually in software.

15.13 PWM Update Lockout

For a complex PWM application, the user may need to write up to four Duty Cycle registers and the Time Base Period register, PTPER, at a given time. In some applications, it is important that all buffer registers be written before the new duty cycle and period values are loaded for use by the module.

The PWM update lockout feature is enabled by setting the UDIS control bit and clearing the IUE control bit in the PWMCON2 SFR. The UDIS bit affects all Duty Cycle Buffer registers and the PWM time base period buffer, PTPER. No duty cycle changes or period value changes will have effect while UDIS = 1.

If the IUE bit is set, any change to the Duty Cycle registers is immediately updated regardless of the bit state of the UDI. The PWM Period register update (PTPER) is not affected by the IUE control bit.

15.14 PWM Special Event Trigger

The PWM module has a special event trigger that allows A/D conversions to be synchronized to the PWM time base. The A/D sampling and conversion time may be programmed to occur at any point within the PWM period. The special event trigger allows the user to minimize the delay between the time when A/D conversion results are acquired and the time when the duty cycle value is updated.

The PWM special event trigger has an SFR named SEVTCMP, and five control bits to control its operation. The PTMR value for which a special event trigger should occur is loaded into the SEVTCMP register. When the PWM time base is in an Up/Down Counting mode, an additional control bit is required to specify the counting phase for the special event trigger. The count phase is selected using the SEVTDIR control bit in the SEVTCMP SFR. If the SEVTDIR bit is cleared, the special event trigger will occur on the upward counting cycle of the PWM time base. If the SEVTDIR bit is set, the special event trigger will occur on the downward count cycle of the PWM time base. The SEVTDIR control bit has no effect unless the PWM time base is configured for an Up/Down Counting mode.

15.14.1 SPECIAL EVENT TRIGGER POSTSCALER

The PWM special event trigger has a postscaler that allows a 1:1 to 1:16 postscale ratio. The postscaler is configured by writing the SEVOPS<3:0> control bits in the PWMCON2 SFR.

The special event output postscaler is cleared on the following events:

- Any write to the SEVTCMP register
- Any device Reset

15.15 PWM Operation During CPU Sleep Mode

The Fault A and Fault B input pins have the ability to wake the CPU from Sleep mode. The PWM module generates an interrupt if either of the Fault pins is driven low while in Sleep.

15.16 PWM Operation During CPU Idle Mode

The PTCON SFR contains a PTSIDL control bit. This bit determines if the PWM module will continue to operate or stop when the device enters Idle mode. If PTSIDL = 0, the module will continue to operate. If PTSIDL = 1, the module will stop operation as long as the CPU remains in Idle mode.

TABLE 15-2: 8-OUTPUT PWM REGISTER MAP⁽¹⁾

SFR Name	Addr	Bit 15	Bit 14	Bit 13	Bit 12	Bit 11	Bit 10	Bit 9	Bit 8	Bit 7	Bit 6	Bit 5	Bit 4	Bit 3	Bit 2	Bit 1	Bit 0	Reset State			
PTCON	01C0	PTEN	—	PTSIDL	—	—	—	—	—	PTOPS<3:0>			PTCKPS<1:0>		PTMOD<1:0>		0000	0000	0000	0000	
PTMR	01C2	PTDIR	PWM Timer Count Value															0000	0000	0000	0000
PTPER	01C4	—	PWM Time Base Period Register															0111	1111	1111	1111
SEVTCMP	01C6	SEVTDIR	PWM Special Event Compare Register															0000	0000	0000	0000
PWMCON1	01C8	—	—	—	—	PTMOD4	PTMOD3	PTMOD2	PTMOD1	PEN4H	PEN3H	PEN2H	PEN1H	PEN4L	PEN3L	PEN2L	PEN1L	0000	0000	1111	1111
PWMCON2	01CA	—	—	—	—	SEVOPS<3:0>			—	—	—	—	—	IUE	OSYNC	UDIS	0000	0000	0000	0000	
DTCON1	01CC	DTBPS<1:0>		Dead-Time B Value					DTAPS<1:0>		Dead-Time A Value						0000	0000	0000	0000	
DTCON2	01CE	—	—	—	—	—	—	—	—	DTS4A	DTS4I	DTS3A	DTS3I	DTS2A	DTS2I	DTS1A	DTS1I	0000	0000	0000	0000
FLTACON	01D0	FAOV4H	FAOV4L	FAOV3H	FAOV3L	FAOV2H	FAOV2L	FAOV1H	FAOV1L	FLTAM	—	—	—	FAEN4	FAEN3	FAEN2	FAEN1	0000	0000	0000	0000
FLTBCON	01D2	FBOV4H	FBOV4L	FBOV3H	FBOV3L	FBOV2H	FBOV2L	FBOV1H	FBOV1L	FLTBM	—	—	—	FBEN4	FBEN3	FBEN2	FBEN1	0000	0000	0000	0000
OVDCON	01D4	POVD4H	POVD4L	POVD3H	POVD3L	POVD2H	POVD2L	POVD1H	POVD1L	POUT4H	POUT4L	POUT3H	POUT3L	POUT2H	POUT2L	POUT1H	POUT1L	1111	1111	0000	0000
PDC1	01D6	PWM Duty Cycle 1 Register															0000	0000	0000	0000	
PDC2	01D8	PWM Duty Cycle 2 Register															0000	0000	0000	0000	
PDC3	01DA	PWM Duty Cycle 3 Register															0000	0000	0000	0000	
PDC4	01DC	PWM Duty Cycle 4 Register															0000	0000	0000	0000	

Legend: u = uninitialized bit; — = unimplemented bit, read as '0'

Note 1: Refer to the "dsPIC30F Family Reference Manual" (DS70046) for descriptions of register bit fields.

dsPIC30F5015/5016

NOTES:

16.0 SPI MODULE

Note: This data sheet summarizes features of this group of dsPIC30F devices and is not intended to be a complete reference source. For more information on the CPU, peripherals, register descriptions and general device functionality, refer to the “*dsPIC30F Family Reference Manual*” (DS70046). For more information on the device instruction set and programming, refer to the “*16-bit MCU and DSC Programmer’s Reference Manual*” (DS70157).

The Serial Peripheral Interface (SPI) module is a synchronous serial interface. It is useful for communicating with other peripheral devices such as EEPROMs, shift registers, display drivers and A/D converters, or other microcontrollers. It is compatible with Motorola’s SPI and SIOP interfaces.

16.1 Operating Function Description

Each SPI module consists of a 16-bit Shift register, SPIxSR (where x = 1 or 2), used for shifting data in and out, and a Buffer register, SPIxBUF. A Control register, SPIxCON, configures the module. Additionally, a status register, SPIxSTAT, indicates various status conditions.

The serial interface consists of 4 pins: SDIx (serial data input), SDOx (serial data output), SCKx (shift clock input or output), and SSx (active-low slave select).

In Master mode operation, SCK is a clock output, but in Slave mode, it is a clock input.

A series of eight (8) or sixteen (16) clock pulses shifts out bits from the SPIxSR to SDOx pin and simultaneously shifts in data from SDIx pin. An interrupt is generated when the transfer is complete and the corresponding Interrupt Flag bit (SPI1IF or SPI2IF) is set. This interrupt can be disabled through an Interrupt Enable bit (SPI1IE or SPI2IE).

The receive operation is double-buffered. When a complete byte is received, it is transferred from SPIxSR to SPIxBUF.

If the receive buffer is full when new data is being transferred from SPIxSR to SPIxBUF, the module will set the SPIROV bit, indicating an overflow condition. The transfer of the data from SPIxSR to SPIxBUF will not be completed and the new data will be lost. The

module will not respond to SCL transitions while SPIROV is ‘1’, effectively disabling the module until SPIxBUF is read by user software.

Note: The user must perform reads of SPIxBUF if the module is used in a transmit only configuration to avoid a receive overflow condition (SPIROV = 1).

Transmit writes are also double-buffered. The user writes to SPIxBUF. When the master or slave transfer is completed, the contents of the Shift register (SPIxSR) is moved to the receive buffer. If any transmit data has been written to the Buffer register, the contents of the transmit buffer are moved to SPIxSR. The received data is thus placed in SPIxBUF and the transmit data in SPIxSR is ready for the next transfer.

Note: Both the transmit buffer (SPIxTXB) and the receive buffer (SPIxRXB) are mapped to the same register address, SPIxBUF.

In Master mode, the clock is generated by prescaling the system clock. Data is transmitted as soon as a value is written to SPIxBUF. The interrupt is generated at the middle of the transfer of the last bit.

In Slave mode, data is transmitted and received as external clock pulses appear on SCK. Again, the interrupt is generated when the last bit is latched. If SSx control is enabled, then transmission and reception are enabled only when SSx = low. The SDOx output will be disabled in SSx mode with SSx high.

The clock provided to the module is (Fosc/4). This clock is then prescaled by the primary (PPRE<1:0>) and the secondary (SPRE<2:0>) prescale factors. The CKE bit determines whether transmit occurs on transition from active clock state to Idle clock state, or vice versa. The CKP bit selects the Idle state (high or low) for the clock.

16.1.1 WORD AND BYTE COMMUNICATION

A control bit, MODE16 (SPIxCON<10>), allows the module to communicate in either 16-bit or 8-bit mode. 16-bit operation is identical to 8-bit operation, except that the number of bits transmitted is 16 instead of 8.

The user software must disable the module prior to changing the MODE16 bit. The SPI module is reset when the MODE16 bit is changed by the user.

A basic difference between 8-bit and 16-bit operation is that the data is transmitted out of bit 7 of the SPIxSR for 8-bit operation, and data is transmitted out of bit 15 of the SPIxSR for 16-bit operation. In both modes, data is shifted into bit 0 of the SPIxSR.

dsPIC30F5015/5016

16.1.2 SDOx DISABLE

A control bit, DISSDO, is provided to the SPIxCON register to allow the SDOx output to be disabled. This will allow the SPI module to be connected in an input only configuration. SDO can also be used for general purpose I/O.

FIGURE 16-1: SPI BLOCK DIAGRAM

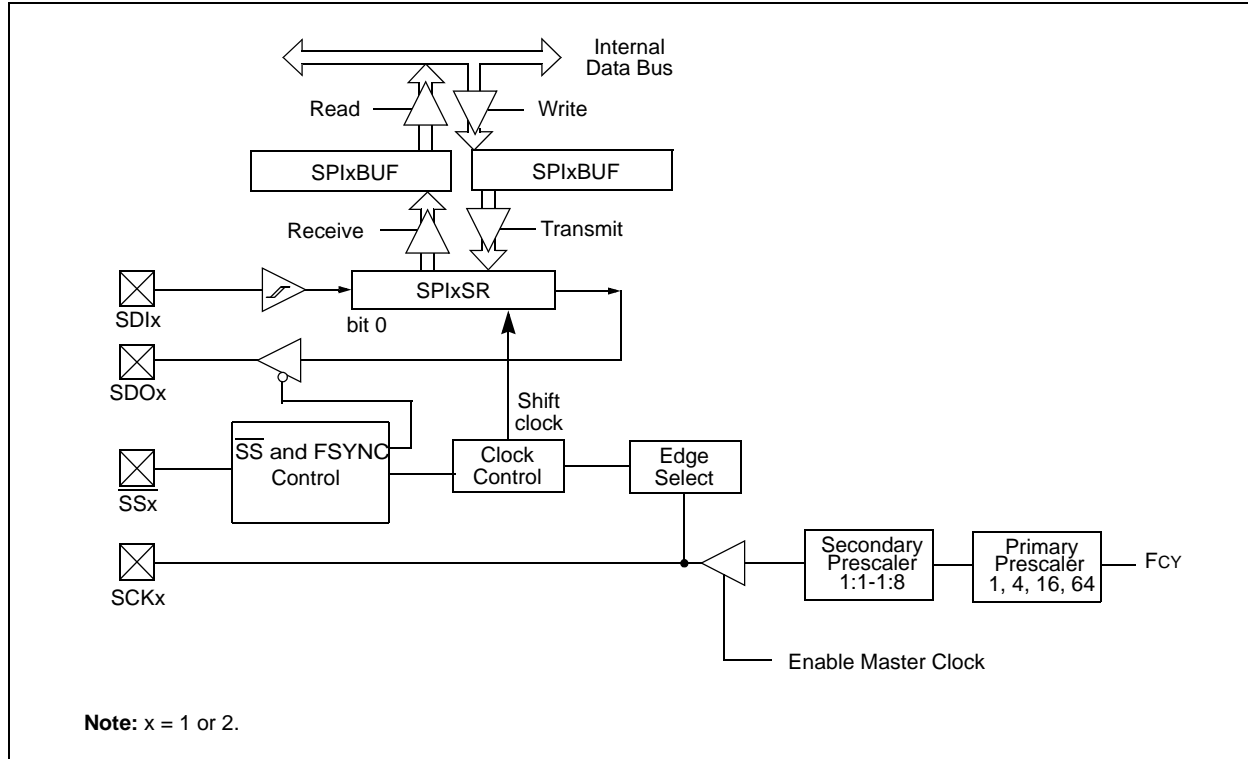
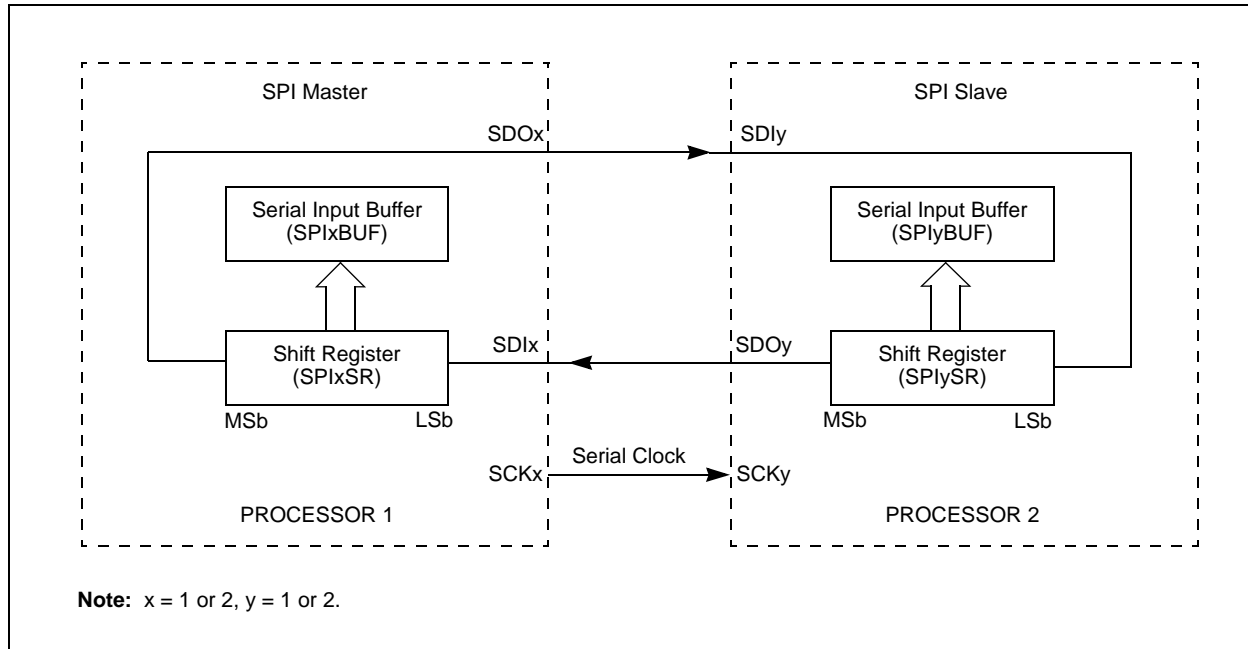

FIGURE 16-2: SPI MASTER/SLAVE CONNECTION



16.2 Framed SPI Support

The module supports a basic framed SPI protocol in Master or Slave mode. The control bit `FRMEN` enables framed SPI support and causes the `SSx` pin to perform the frame synchronization pulse (FSYNC) function. The control bit, `SPIFSD`, determines whether the `SSx` pin is an input or an output (i.e., whether the module receives or generates the frame synchronization pulse). The frame pulse is an active-high pulse for a single SPI clock cycle. When frame synchronization is enabled, the data transmission starts only on the subsequent transmit edge of the SPI clock.

16.3 Slave Select Synchronization

The `SSx` pin allows a Synchronous Slave mode. The SPI must be configured in SPI Slave mode, with `SSx` pin control enabled (`SSEN = 1`). When the `SSx` pin is low, transmission and reception are enabled, and the `SDOx` pin is driven. When `SSx` pin goes high, the `SDOx` pin is no longer driven. Also, the SPI module is re-synchronized, and all counters/control circuitry are reset. Therefore, when the `SSx` pin is asserted low again, transmission/reception will begin at the MSb, even if `SSx` had been deasserted in the middle of a transmit/receive.

16.4 SPI Operation During CPU Sleep Mode

During Sleep mode, the SPI module is shutdown. If the CPU enters Sleep mode while an SPI transaction is in progress, then the transmission and reception is aborted.

The transmitter and receiver will stop in Sleep mode. However, register contents are not affected by entering or exiting Sleep mode.

16.5 SPI Operation During CPU Idle Mode

When the device enters Idle mode, all clock sources remain functional. The `SPISIDL` bit (`SPIxSTAT<13>`) selects if the SPI module will stop or continue on Idle. If `SPISIDL = 0`, the module will continue to operate when the CPU enters Idle mode. If `SPISIDL = 1`, the module will stop when the CPU enters Idle mode.

TABLE 16-1: SPI1 REGISTER MAP⁽¹⁾

SFR Name	Addr.	Bit 15	Bit 14	Bit 13	Bit 12	Bit 11	Bit 10	Bit 9	Bit 8	Bit 7	Bit 6	Bit 5	Bit 4	Bit 3	Bit 2	Bit 1	Bit 0	Reset State
SPI1STAT	0220	SPIEN	—	SPISIDL	—	—	—	—	—	—	SPIROV	—	—	—	—	SPITBF	SPIRBF	0000 0000 0000 0000
SPI1CON	0222	—	FRMEN	SPIFSD	—	DISSDO	MODE16	SMP	CKE	SSEN	CKP	MSTEN	SPRE2	SPRE1	SPRE0	PPRE1	PPRE0	0000 0000 0000 0000
SPI1BUF	0224	Transmit and Receive Buffer																0000 0000 0000 0000

Legend: — = unimplemented bit, read as '0'

Note 1: Refer to the "dsPIC30F Family Reference Manual" (DS70046) for descriptions of register bit fields.

TABLE 16-2: SPI2 REGISTER MAP⁽¹⁾

SFR Name	Addr.	Bit 15	Bit 14	Bit 13	Bit 12	Bit 11	Bit 10	Bit 9	Bit 8	Bit 7	Bit 6	Bit 5	Bit 4	Bit 3	Bit 2	Bit 1	Bit 0	Reset State
SPI2STAT	0226	SPIEN	—	SPISIDL	—	—	—	—	—	—	SPIROV	—	—	—	—	SPITBF	SPIRBF	0000 0000 0000 0000
SPI2CON	0228	—	FRMEN	SPIFSD	—	DISSDO	MODE16	SMP	CKE	SSEN	CKP	MSTEN	SPRE2	SPRE1	SPRE0	PPRE1	PPRE0	0000 0000 0000 0000
SPI2BUF	022A	Transmit and Receive Buffer																0000 0000 0000 0000

Legend: — = unimplemented bit, read as '0'

Note 1: Refer to the "dsPIC30F Family Reference Manual" (DS70046) for descriptions of register bit fields.

17.0 I²C™ MODULE

Note: This data sheet summarizes features of this group of dsPIC30F devices and is not intended to be a complete reference source. For more information on the CPU, peripherals, register descriptions and general device functionality, refer to the “dsPIC30F Family Reference Manual” (DS70046). For more information on the device instruction set and programming, refer to the “16-bit MCU and DSC Programmer’s Reference Manual” (DS70157).

The Inter-Integrated Circuit (I²C™) module provides complete hardware support for both Slave and Multi-Master modes of the I²C serial communication standard, with a 16-bit interface.

This module offers the following key features:

- I²C interface supporting both Master and Slave operation.
- I²C Slave mode supports 7-bit and 10-bit addressing.
- I²C Master mode supports 7-bit and 10-bit addressing.
- I²C port allows bidirectional transfers between master and slaves.
- Serial clock synchronization for I²C port can be used as a handshake mechanism to suspend and resume serial transfer (SCLREL control).
- I²C supports Multi-Master operation; detects bus collision and will arbitrate accordingly.

17.1 Operating Function Description

The hardware fully implements all the master and slave functions of the I²C Standard and Fast mode specifications, as well as 7 and 10-bit addressing.

Thus, the I²C module can operate either as a slave or a master on an I²C bus.

17.1.1 VARIOUS I²C MODES

The following types of I²C operation are supported:

- I²C Slave operation with 7-bit addressing
- I²C Slave operation with 10-bit addressing
- I²C Master operation with 7-bit or 10-bit addressing

See the I²C programmer’s model in [Figure 17-1](#).

17.1.2 PIN CONFIGURATION IN I²C MODE

I²C has a 2-pin interface; pin SCL is clock and pin SDA is data.

17.1.3 I²C REGISTERS

I2CCON and I2CSTAT are control and status registers, respectively. The I2CCON register is readable and writable. The lower 6 bits of I2CSTAT are read-only. The remaining bits of the I2CSTAT are read/write.

I2CRSR is the Shift register used for shifting data, whereas I2CRCV is the Buffer register to which data bytes are written, or from which data bytes are read. I2CRCV is the Receive buffer, as shown in Figure 16-1. I2CTRN is the Transmit register to which bytes are written during a transmit operation, as shown in Figure 16-2.

The I2CADD register holds the slave address. A Status bit, ADD10, indicates 10-bit Address mode. The I2CBRG acts as the Baud Rate Generator (BRG) reload value.

In receive operations, I2CRSR and I2CRCV together form a double-buffered receiver. When I2CRSR receives a complete byte, it is transferred to I2CRCV and an interrupt pulse is generated. During transmission, the I2CTRN is not double-buffered.

Note: Following a Restart condition in 10-bit mode, the user only needs to match the first 7-bit address.

FIGURE 17-1: PROGRAMMER’S MODEL

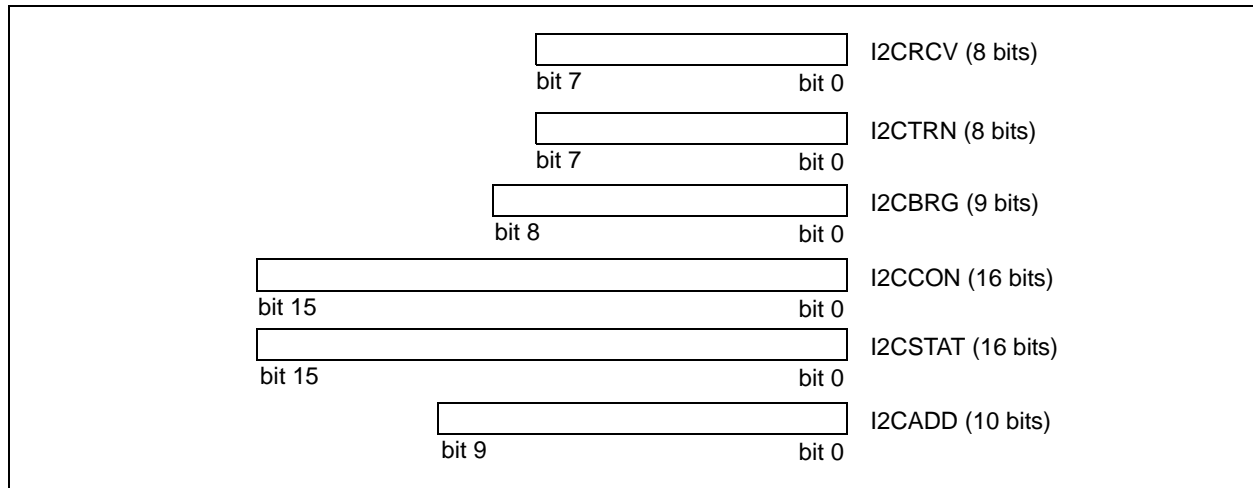

dsPIC30F5015/5016

FIGURE 17-2: I²C™ BLOCK DIAGRAM

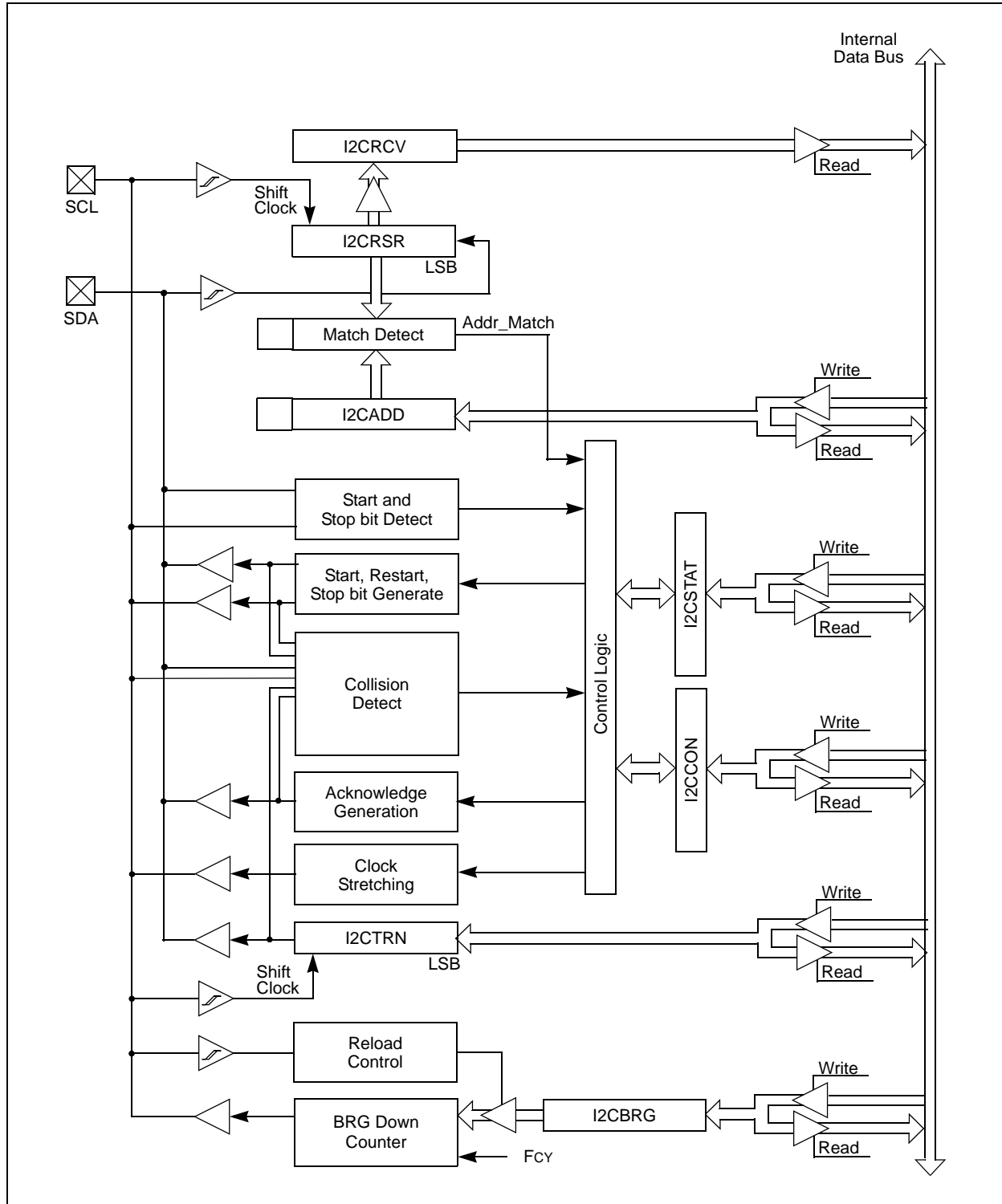

17.2 I²C Module Addresses

The I2CADD register contains the Slave mode addresses. The register is a 10-bit register.

If the A10M bit (I2CCON<10>) is '0', the address is interpreted by the module as a 7-bit address. When an address is received, it is compared to the 7 LSbs of the I2CADD register.

If the A10M bit is '1', the address is assumed to be a 10-bit address. When an address is received, it is compared with the binary value '1 1 1 1 0 A9 A8' (where A9, A8 are two Most Significant bits of I2CADD). If that value matches, the next address is compared with the Least Significant 8 bits of I2CADD, as specified in the 10-bit addressing protocol.

TABLE 17-1: 7-BIT I²C™ SLAVE ADDRESSES SUPPORTED BY dsPIC30F

Address	Description
0x00	General call address or start byte
0x01-0x03	Reserved
0x04-0x07	HS mode Master codes
0x08-0x77	Valid 7-bit addresses
0x78-0x7b	Valid 10-bit addresses (lower 7 bits)
0x7c-0x7f	Reserved

17.3 I²C 7-bit Slave Mode Operation

Once enabled (I2CEN = 1), the slave module will wait for a Start bit to occur (i.e., the I²C module is 'Idle'). Following the detection of a Start bit, 8 bits are shifted into I2CRSR and the address is compared against I2CADD. In 7-bit mode (A10M = 0), bits I2CADD<6:0> are compared against I2CRSR<7:1> and I2CRSR<0> is the R_W bit. All incoming bits are sampled on the rising edge of SCL.

If an address match occurs, an Acknowledgement will be sent, and the Slave Event Interrupt Flag (SI2CIF) is set on the falling edge of the ninth (ACK) bit. The address match does not affect the contents of the I2CRCV buffer or the RBF bit.

17.3.1 SLAVE TRANSMISSION

If the R_W bit received is a '1', then the serial port will go into Transmit mode. It will send ACK on the ninth bit and then hold SCL to '0' until the CPU responds by writing to I2CTRN. SCL is released by setting the SCLREL bit, and 8 bits of data are shifted out. Data bits are shifted out on the falling edge of SCL, such that SDA is valid during SCL high (see timing diagram). The interrupt pulse is sent on the falling edge of the ninth clock pulse, regardless of the status of the ACK received from the master.

17.3.2 SLAVE RECEPTION

If the R_W bit received is a '0' during an address match, then Receive mode is initiated. Incoming bits are sampled on the rising edge of SCL. After 8 bits are received, if I2CRCV is not full or I2COV is not set, I2CRSR is transferred to I2CRCV. ACK is sent on the ninth clock.

If the RBF flag is set, indicating that I2CRCV is still holding data from a previous operation (RBF = 1), then ACK is not sent; however, the interrupt pulse is generated. In the case of an overflow, the contents of the I2CRSR are not loaded into the I2CRCV.

Note: The I2CRCV will be loaded if the I2COV bit = 1 and the RBF flag = 0. In this case, a read of the I2CRCV was performed, but the user did not clear the state of the I2COV bit before the next receive occurred. The Acknowledgement is not sent (ACK = 1) and the I2CRCV is updated.

17.4 I²C 10-bit Slave Mode Operation

In 10-bit mode, the basic receive and transmit operations are the same as in the 7-bit mode. However, the criteria for address match is more complex.

The I²C specification dictates that a slave must be addressed for a write operation, with two address bytes following a Start bit.

The A10M bit is a control bit that signifies that the address in I2CADD is a 10-bit address rather than a 7-bit address. The address detection protocol for the first byte of a message address is identical for 7-bit and 10-bit messages, but the bits being compared are different.

I2CADD holds the entire 10-bit address. Upon receiving an address following a Start bit, I2CRSR <7:3> is compared against a literal '11110' (the default 10-bit address) and I2CRSR<2:1> are compared against I2CADD<9:8>. If a match occurs and if R_W = 0, the interrupt pulse is sent. The ADD10 bit will be cleared to indicate a partial address match. If a match fails or R_W = 1, the ADD10 bit is cleared and the module returns to the Idle state.

The low byte of the address is then received and compared with I2CADD<7:0>. If an address match occurs, the interrupt pulse is generated and the ADD10 bit is set, indicating a complete 10-bit address match. If an address match did not occur, the ADD10 bit is cleared and the module returns to the Idle state.

dsPIC30F5015/5016

17.4.1 10-BIT MODE SLAVE TRANSMISSION

Once a slave is addressed in this fashion, with the full 10-bit address (we will refer to this state as "PRIOR_ADDR_MATCH"), the master can begin sending data bytes for a slave reception operation.

17.4.2 10-BIT MODE SLAVE RECEPTION

Once addressed, the master can generate a Repeated Start, reset the high byte of the address and set the R_W bit without generating a Stop bit, thus initiating a slave transmit operation.

17.5 Automatic Clock Stretch

In the slave modes, the module can synchronize buffer reads and write to the master device by clock stretching.

17.5.1 TRANSMIT CLOCK STRETCHING

Both 10-bit and 7-bit transmit modes implement clock stretching by asserting the SCLREL bit after the falling edge of the ninth clock if the TBF bit is cleared, indicating the buffer is empty.

In slave transmit modes, clock stretching is always performed, irrespective of the STREN bit.

Clock synchronization takes place following the ninth clock of the transmit sequence. If the device samples an ACK on the falling edge of the ninth clock, and if the TBF bit is still clear, then the SCLREL bit is automatically cleared. The SCLREL being cleared to '0' will assert the SCL line low. The user's ISR must set the SCLREL bit before transmission is allowed to continue. By holding the SCL line low, the user has time to service the ISR and load the contents of the I2CTRN before the master device can initiate another transmit sequence.

Note 1: If the user loads the contents of I2CTRN, setting the TBF bit before the falling edge of the ninth clock, the SCLREL bit will not be cleared and clock stretching will not occur.

2: The SCLREL bit can be set in software, regardless of the state of the TBF bit.

17.5.2 RECEIVE CLOCK STRETCHING

The STREN bit in the I2CCON register can be used to enable clock stretching in Slave Receive mode. When the STREN bit is set, the SCL pin will be held low at the end of each data receive sequence.

17.5.3 CLOCK STRETCHING DURING 7-BIT ADDRESSING (STREN = 1)

When the STREN bit is set in Slave Receive mode, the SCL line is held low when the Buffer register is full. The method for stretching the SCL output is the same for both 7 and 10-bit addressing modes.

Clock stretching takes place following the ninth clock of the receive sequence. On the falling edge of the ninth clock at the end of the ACK sequence, if the RBF bit is set, the SCLREL bit is automatically cleared, forcing the SCL output to be held low. The user's ISR must set the SCLREL bit before reception is allowed to continue. By holding the SCL line low, the user has time to service the ISR and read the contents of the I2CRCV before the master device can initiate another receive sequence. This will prevent buffer overruns from occurring.

Note 1: If the user reads the contents of the I2CRCV, clearing the RBF bit before the falling edge of the ninth clock, the SCLREL bit will not be cleared and clock stretching will not occur.

2: The SCLREL bit can be set in software, regardless of the state of the RBF bit. The user should be careful to clear the RBF bit in the ISR before the next receive sequence in order to prevent an overflow condition.

17.5.4 CLOCK STRETCHING DURING 10-BIT ADDRESSING (STREN = 1)

Clock stretching takes place automatically during the addressing sequence. Because this module has a register for the entire address, it is not necessary for the protocol to wait for the address to be updated.

After the address phase is complete, clock stretching will occur on each data receive or transmit sequence as was described earlier.

17.6 Software Controlled Clock Stretching (STREN = 1)

When the STREN bit is '1', the SCLREL bit may be cleared by software to allow software to control the clock stretching. The logic will synchronize writes to the SCLREL bit with the SCL clock. Clearing the SCLREL bit will not assert the SCL output until the module detects a falling edge on the SCL output and SCL is sampled low. If the SCLREL bit is cleared by the user while the SCL line has been sampled low, the SCL output will be asserted (held low). The SCL output will remain low until the SCLREL bit is set, and all other devices on the I²C bus have deasserted SCL. This ensures that a write to the SCLREL bit will not violate the minimum high time requirement for SCL.

If the STREN bit is '0', a software write to the SCLREL bit will be disregarded and have no effect on the SCLREL bit.

17.7 Interrupts

The I²C module generates two interrupt flags, MI2CIF (I²C Master Interrupt Flag) and SI2CIF (I²C Slave Interrupt Flag). The MI2CIF interrupt flag is activated on completion of a master message event. The SI2CIF interrupt flag is activated on detection of a message directed to the slave.

17.8 Slope Control

The I²C standard requires slope control on the SDA and SCL signals for Fast Mode (400 kHz). The control bit, DISSLW, enables the user to disable slew rate control, if desired. It is necessary to disable the slew rate control for 1 MHz mode.

17.9 IPMI Support

The control bit, IPMIEN, enables the module to support Intelligent Peripheral Management Interface (IPMI). When this bit is set, the module accepts and acts upon all addresses.

17.10 General Call Address Support

The general call address can address all devices. When this address is used, all devices should, in theory, respond with an Acknowledgement.

The general call address is one of eight addresses reserved for specific purposes by the I²C protocol. It consists of all '0's with R_W = 0.

The general call address is recognized when the General Call Enable bit (GCEN) is set (I2CCON<7> = 1). Following a Start bit detection, 8 bits are shifted into I2CRSR and the address is compared with I2CADD, and is also compared with the general call address which is fixed in hardware.

If a general call address match occurs, the I2CRSR is transferred to the I2CRCV after the eighth clock, the RBF flag is set, and on the falling edge of the ninth bit ($\overline{\text{ACK}}$ bit), the master event interrupt flag (MI2CIF) is set.

When the interrupt is serviced, the source for the interrupt can be checked by reading the contents of the I2CRCV to determine if the address was device specific, or a general call address.

17.11 I²C Master Support

As a Master device, six operations are supported.

- Assert a Start condition on SDA and SCL.
- Assert a Restart condition on SDA and SCL.
- Write to the I2CTRN register initiating transmission of data/address.
- Generate a Stop condition on SDA and SCL.
- Configure the I²C port to receive data.
- Generate an $\overline{\text{ACK}}$ condition at the end of a received byte of data.

17.12 I²C Master Operation

The master device generates all of the serial clock pulses and the Start and Stop conditions. A transfer is ended with a Stop condition or with a Repeated Start condition. Since the Repeated Start condition is also the beginning of the next serial transfer, the I²C bus will not be released.

In Master Transmitter mode, serial data is output through SDA, while SCL outputs the serial clock. The first byte transmitted contains the slave address of the receiving device (7 bits) and the data direction bit. In this case, the data direction bit (R_W) is logic '0'. Serial data is transmitted 8 bits at a time. After each byte is transmitted, an $\overline{\text{ACK}}$ bit is received. Start and Stop conditions are output to indicate the beginning and the end of a serial transfer.

In Master Receive mode, the first byte transmitted contains the slave address of the transmitting device (7 bits) and the data direction bit. In this case, the data direction bit (R_W) is logic '1'. Thus, the first byte transmitted is a 7-bit slave address, followed by a '1' to indicate receive bit. Serial data is received via SDA, while SCL outputs the serial clock. Serial data is received 8 bits at a time. After each byte is received, an $\overline{\text{ACK}}$ bit is transmitted. Start and Stop conditions indicate the beginning and end of transmission.

17.12.1 I²C MASTER TRANSMISSION

Transmission of a data byte, a 7-bit address, or the second half of a 10-bit address is accomplished by simply writing a value to I2CTRN register. The user should only write to I2CTRN when the module is in a WAIT state. This action will set the buffer full flag (TBF) and allow the Baud Rate Generator to begin counting and start the next transmission. Each bit of address/data will be shifted out onto the SDA pin after the falling edge of SCL is asserted. The Transmit Status Flag, TRSTAT (I2CSTAT<14>), indicates that a master transmit is in progress.

17.12.2 I²C MASTER RECEPTION

Master mode reception is enabled by programming the receive enable (RCEN) bit (I2CCON<3>). The I²C module must be Idle before the RCEN bit is set, otherwise the RCEN bit will be disregarded. The Baud Rate Generator begins counting, and on each rollover, the state of the SCL pin toggles, and data is shifted in to the I2CRSR on the rising edge of each clock.

17.12.3 BAUD RATE GENERATOR

In I²C Master mode, the reload value for the BRG is located in the I2CBRG register. When the BRG is loaded with this value, the BRG counts down to '0' and stops until another reload has taken place. If clock arbitration is taking place, for instance, the BRG is reloaded when the SCL pin is sampled high.

dsPIC30F5015/5016

As per the I²C standard, FSK may be 100 kHz or 400 kHz. However, the user can specify any baud rate up to 1 MHz. I2CBRG values of '0' or '1' are illegal.

EQUATION 17-1: SERIAL CLOCK RATE

$$I2CBRG = \left(\frac{FCY}{FSCL} - \frac{FCY}{1, 111, 111} \right) - 1$$

17.12.4 CLOCK ARBITRATION

Clock arbitration occurs when the master de-asserts the SCL pin (SCL allowed to float high) during any receive, transmit, or Restart/Stop condition. When the SCL pin is allowed to float high, the Baud Rate Generator is suspended from counting until the SCL pin is actually sampled high. When the SCL pin is sampled high, the Baud Rate Generator is reloaded with the contents of I2CBRG and begins counting. This ensures that the SCL high time will always be at least one BRG rollover count in the event that the clock is held low by an external device.

17.12.5 MULTI-MASTER COMMUNICATION, BUS COLLISION AND BUS ARBITRATION

Multi-Master operation support is achieved by bus arbitration. When the master outputs address/data bits onto the SDA pin, arbitration takes place when the master outputs a '1' on SDA, by letting SDA float high while another master asserts a '0'. When the SCL pin floats high, data should be stable. If the expected data on SDA is a '1' and the data sampled on the SDA pin = 0, then a bus collision has taken place. The master will set the MI2CIF pulse and reset the master portion of the I²C port to its Idle state.

If a transmit was in progress when the bus collision occurred, the transmission is halted, the TBF flag is cleared, the SDA and SCL lines are deasserted, and a value can now be written to I2CTRN. When the user services the I²C master event Interrupt Service Routine, if the I²C bus is free (i.e., the P bit is set), the user can resume communication by asserting a Start condition.

If a Start, Restart, Stop or Acknowledge condition was in progress when the bus collision occurred, the condition is aborted, the SDA and SCL lines are deasserted, and the respective control bits in the I2CCON register are cleared to '0'. When the user services the bus collision Interrupt Service Routine, and if the I²C bus is free, the user can resume communication by asserting a Start condition.

The Master will continue to monitor the SDA and SCL pins, and if a Stop condition occurs, the MI2CIF bit will be set.

A write to the I2CTRN will start the transmission of data at the first data bit, regardless of where the transmitter left off when bus collision occurred.

In a Multi-Master environment, the interrupt generation on the detection of Start and Stop conditions allows the determination of when the bus is free. Control of the I²C bus can be taken when the P bit is set in the I2CSTAT register, or the bus is Idle and the S and P bits are cleared.

17.13 I²C Module Operation During CPU Sleep and Idle Modes

17.13.1 I²C OPERATION DURING CPU SLEEP MODE

When the device enters Sleep mode, all clock sources to the module are shutdown and stay at logic '0'. If Sleep occurs in the middle of a transmission, and the state machine is partially into a transmission as the clocks stop, then the transmission is aborted. Similarly, if Sleep occurs in the middle of a reception, then the reception is aborted.

17.13.2 I²C OPERATION DURING CPU IDLE MODE

For the I²C, the I2CSIDL bit selects if the module will stop on Idle or continue on Idle. If I2CSIDL = 0, the module will continue operation on assertion of the Idle mode. If I2CSIDL = 1, the module will stop on Idle.

TABLE 17-2: I²C™ REGISTER MAP⁽¹⁾

SFR Name	Addr.	Bit 15	Bit 14	Bit 13	Bit 12	Bit 11	Bit 10	Bit 9	Bit 8	Bit 7	Bit 6	Bit 5	Bit 4	Bit 3	Bit 2	Bit 1	Bit 0	Reset State
I2CRCV	0200	—	—	—	—	—	—	—	—	Receive Register								0000 0000 0000 0000
I2CTRN	0202	—	—	—	—	—	—	—	—	Transmit Register								0000 0000 1111 1111
I2CBRG	0204	—	—	—	—	—	—	—	Baud Rate Generator								0000 0000 0000 0000	
I2CCON	0206	I2CEN	—	I2CSIDL	SCLREL	IPMIEN	A10M	DISSLW	SMEN	GCEN	STREN	ACKDT	ACKEN	RCEN	PEN	RSEN	SEN	0001 0000 0000 0000
I2CSTAT	0208	ACKSTAT	TRSTAT	—	—	—	BCL	GCSTAT	ADD10	IWCOL	I2COV	D_A	P	S	R_W	RBF	TBF	0000 0000 0000 0000
I2CADD	020A	—	—	—	—	—	—	Address Register								0000 0000 0000 0000		

Legend: — = unimplemented bit, read as '0'

Note 1: Refer to the "dsPIC30F Family Reference Manual" (DS70046) for descriptions of register bit fields.

dsPIC30F5015/5016

NOTES:

18.0 UNIVERSAL ASYNCHRONOUS RECEIVER TRANSMITTER (UART) MODULE

Note: This data sheet summarizes features of this group of dsPIC30F devices and is not intended to be a complete reference source. For more information on the CPU, peripherals, register descriptions and general device functionality, refer to the “dsPIC30F Family Reference Manual” (DS70046). For more information on the device instruction set and programming, refer to the “16-bit MCU and DSC Programmer’s Reference Manual” (DS70157).

This section describes the Universal Asynchronous Receiver/Transmitter Communications module.

18.1 UART Module Overview

The key features of the UART module are:

- Full-duplex, 8 or 9-bit data communication
- Even, Odd or No Parity options (for 8-bit data)
- One or two Stop bits
- Fully integrated Baud Rate Generator with 16-bit prescaler
- Baud rates range from 38 bps to 1.875 Mbps at a 30 MHz instruction rate
- 4-word deep transmit data buffer
- 4-word deep receive data buffer
- Parity, Framing and Buffer Overrun error detection
- Support for Interrupt only on Address Detect (9th bit = 1)
- Separate Transmit and Receive Interrupts
- Loopback mode for diagnostic support

FIGURE 18-1: UART TRANSMITTER BLOCK DIAGRAM

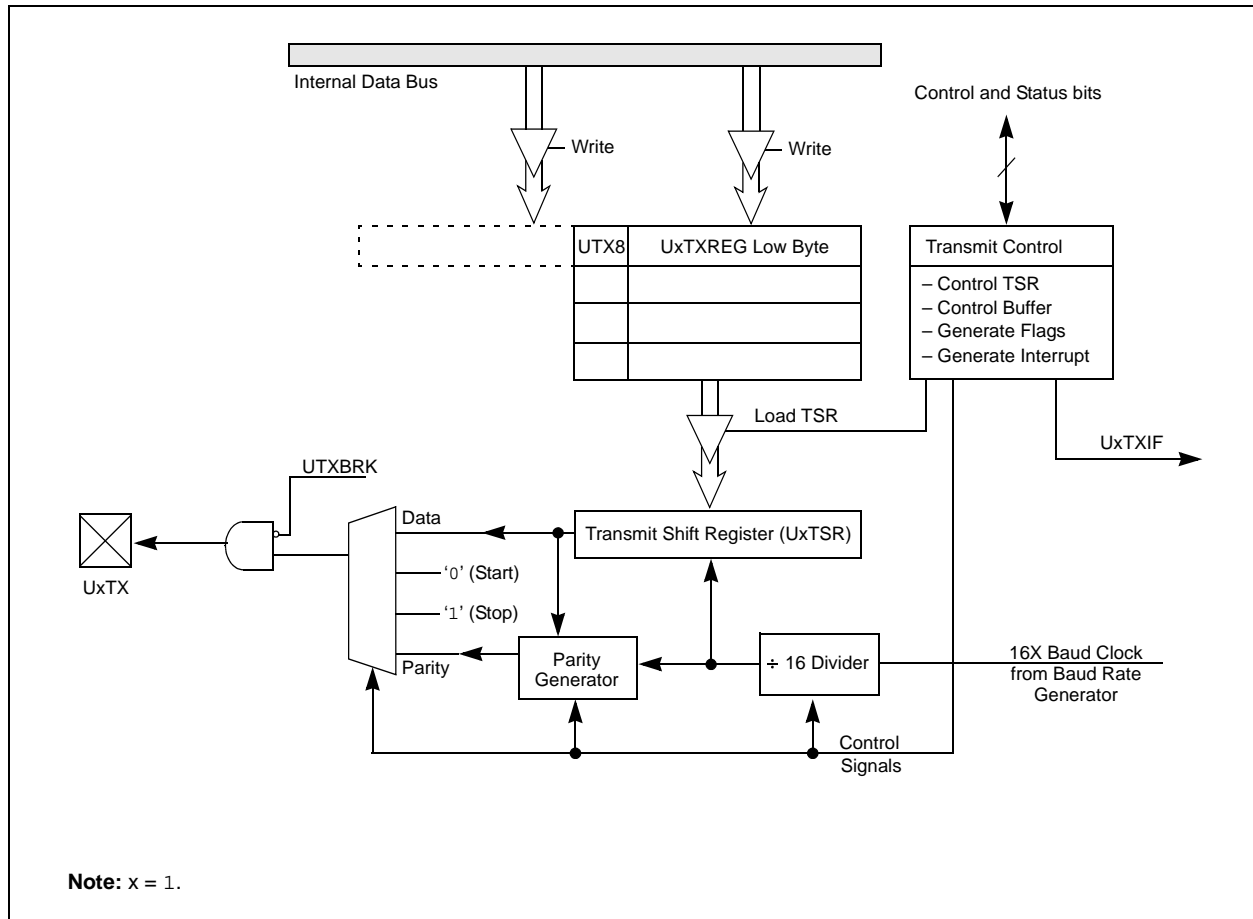

dsPIC30F5015/5016

FIGURE 18-2: UART RECEIVER BLOCK DIAGRAM

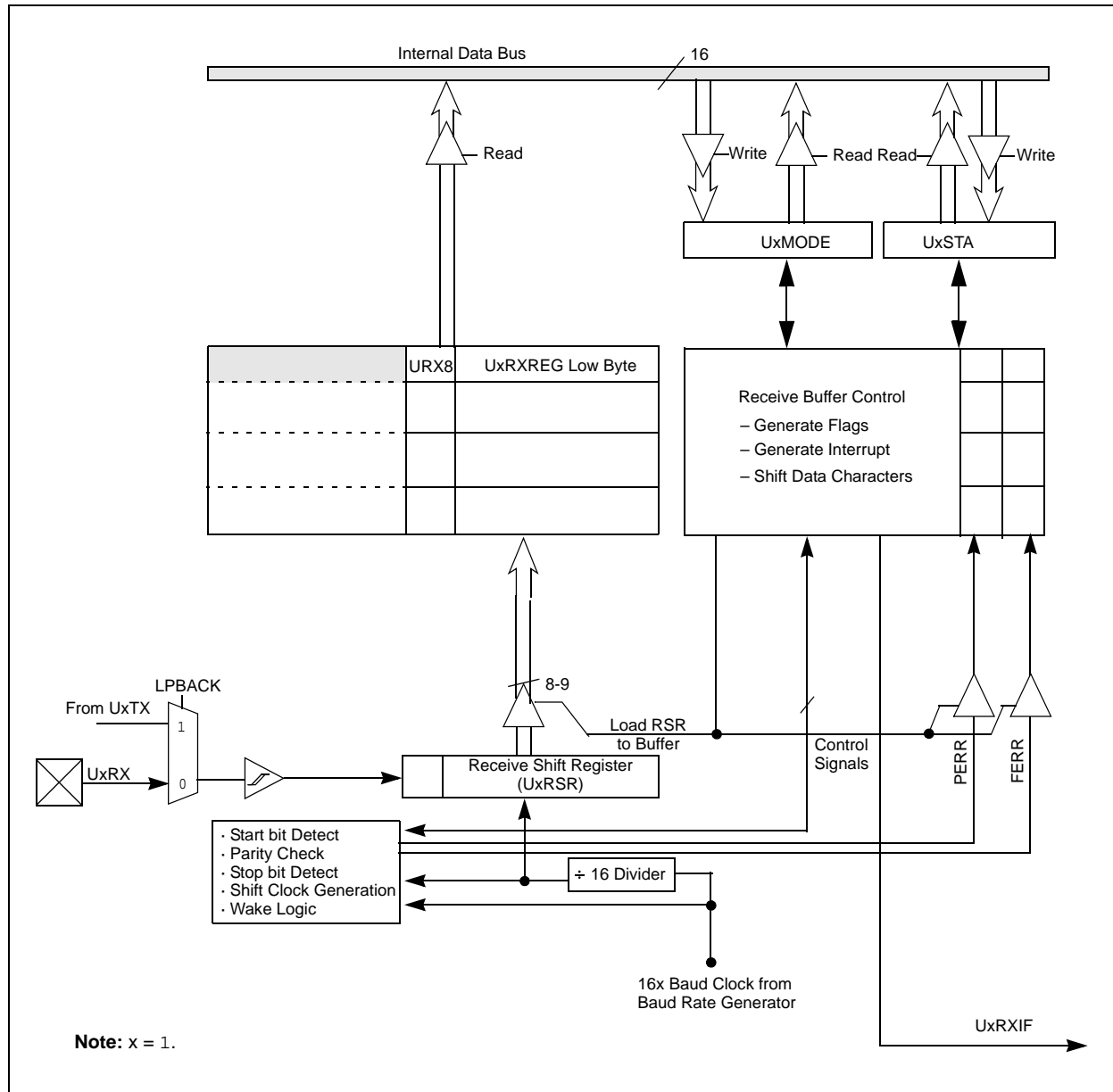

18.2 Enabling and Setting Up UART

18.2.1 ENABLING THE UART

The UART module is enabled by setting the UARTEN bit in the UxMODE register (where x = 1). Once enabled, the UxTX and UxRX pins are configured as an output and an input respectively, overriding the TRIS and LATCH register bit settings for the corresponding I/O port pins. The UxTX pin is at logic '1' when no transmission is taking place.

18.2.2 DISABLING THE UART

The UART module is disabled by clearing the UARTEN bit in the UxMODE register. This is the default state after any Reset. If the UART is disabled, all I/O pins operate as port pins under the control of the latch and TRIS bits of the corresponding port pins.

Disabling the UART module resets the buffers to empty states. Any data characters in the buffers are lost, and the baud rate counter is reset.

All error and status flags associated with the UART module are reset when the module is disabled. The URXDA, OERR, FERR, PERR, UTXEN, UTXBRK and UTXBF bits are cleared, whereas RIDLE and TRMT are set. Other control bits, including ADDEN, URXISEL<1:0>, UTXISEL, as well as the UxMODE and UxBRG registers, are not affected.

Clearing the UARTEN bit while the UART is active will abort all pending transmissions and receptions and reset the module as defined above. Re-enabling the UART will restart the UART in the same configuration.

18.2.3 SETTING UP DATA, PARITY AND STOP BIT SELECTIONS

Control bits, PDSEL<1:0>, in the UxMODE register are used to select the data length and parity used in the transmission. The data length may either be 8 bits with even, odd or no parity, or 9 bits with no parity.

The STSEL bit determines whether one or two Stop bits will be used during data transmission.

The default (Power-on) setting of the UART is 8 bits, no parity, 1 Stop bit (typically represented as 8, N, 1).

18.3 Transmitting Data

18.3.1 TRANSMITTING IN 8-BIT DATA MODE

The following steps must be performed in order to transmit 8-bit data:

1. Set up the UART:
First, the data length, parity and number of Stop bits must be selected. Then, the Transmit and Receive Interrupt enable and priority bits are setup in the UxMODE and UxSTA registers. Also, the appropriate baud rate value must be written to the UxBRG register.
2. Enable the UART by setting the UARTEN bit (UxMODE<15>).
3. Set the UTXEN bit (UxSTA<10>), thereby enabling a transmission.

Note: The UTXEN bit must be set after the UARTEN bit is set to enable UART transmissions.

4. Write the byte to be transmitted to the lower byte of UxTXREG. The value will be transferred to the Transmit Shift register (UxTSR) immediately and the serial bit stream will start shifting out during the next rising edge of the baud clock. Alternatively, the data byte may be written while UTXEN = 0, following which, the user may set UTXEN. This will cause the serial bit stream to begin immediately because the baud clock will start from a cleared state.
5. A Transmit interrupt will be generated depending on the value of the interrupt control bit UTXISEL (UxSTA<15>).

18.3.2 TRANSMITTING IN 9-BIT DATA MODE

The sequence of steps involved in the transmission of 9-bit data is similar to 8-bit transmission, except that a 16-bit data word (of which the upper 7 bits are always clear) must be written to the UxTXREG register.

18.3.3 TRANSMIT BUFFER (UxTXB)

The transmit buffer is 9 bits wide and 4 characters deep. Including the Transmit Shift register (UxTSR), the user effectively has a 5-deep FIFO (First-In, First-Out) buffer. The UTXBF Status bit (UxSTA<9>) indicates whether the transmit buffer is full.

If a user attempts to write to a full buffer, the new data will not be accepted into the FIFO, and no data shift will occur within the buffer. This enables recovery from a buffer overrun condition.

The FIFO is reset during any device Reset, but is not affected when the device enters or wakes up from a Power-Saving mode.

18.3.4 TRANSMIT INTERRUPT

The transmit interrupt flag (U1TXIF) is located in the corresponding Interrupt Flag register.

The transmitter generates an edge to set the UxTXIF bit. The condition for generating the interrupt depends on UTXISEL control bit:

- If UTXISEL = 0, an interrupt is generated when a word is transferred from the Transmit buffer to the Transmit Shift register (UxTSR). This implies that the transmit buffer has at least one empty word.
- If UTXISEL = 1, an interrupt is generated when a word is transferred from the Transmit buffer to the Transmit Shift register (UxTSR) and the Transmit buffer is empty.

Switching between the two interrupt modes during operation is possible and sometimes offers more flexibility.

18.3.5 TRANSMIT BREAK

Setting the UTXBRK bit (UxSTA<11>) will cause the UxTX line to be driven to logic '0'. The UTXBRK bit overrides all transmission activity. Therefore, the user should generally wait for the transmitter to be Idle before setting UTXBRK.

To send a break character, the UTXBRK bit must be set by software and must remain set for a minimum of 13 baud clock cycles. The UTXBRK bit is then cleared by software to generate Stop bits. The user must wait for a duration of at least one or two baud clock cycles in order to ensure a valid Stop bit(s) before reloading the UxTXB or starting other transmitter activity. Transmission of a break character does not generate a transmit interrupt.

18.4 Receiving Data

18.4.1 RECEIVING IN 8-BIT OR 9-BIT DATA MODE

The following steps must be performed while receiving 8-bit or 9-bit data:

1. Set up the UART (see [Section 18.3.1 "Transmitting in 8-bit Data Mode"](#)).
2. Enable the UART (see [Section 18.3.1 "Transmitting in 8-bit Data Mode"](#)).
3. A receive interrupt will be generated when one or more data words have been received, depending on the receive interrupt settings specified by the URXISEL bits (UxSTA<7:6>).
4. Read the OERR bit to determine if an overrun error has occurred. The OERR bit must be reset in software.
5. Read the received data from UxRXREG. The act of reading UxRXREG will move the next word to the top of the receive FIFO, and the PERR and FERR values will be updated.

18.4.2 RECEIVE BUFFER (UxRXB)

The receive buffer is 4 words deep. Including the Receive Shift register (UxRSR), the user effectively has a 5-word deep FIFO buffer.

URXDA (UxSTA<0>) = 1 indicates that the receive buffer has data available. URXDA = 0 implies that the buffer is empty. If a user attempts to read an empty buffer, the old values in the buffer will be read and no data shift will occur within the FIFO.

The FIFO is reset during any device Reset. It is not affected when the device enters or wakes up from a Power-Saving mode.

18.4.3 RECEIVE INTERRUPT

The receive interrupt flag (U1RXIF or U2RXIF) can be read from the corresponding Interrupt Flag register. The interrupt flag is set by an edge generated by the receiver. The condition for setting the receive interrupt flag depends on the settings specified by the URXISEL<1:0> (UxSTA<7:6>) control bits.

- If URXISEL<1:0> = 00 or 01, an interrupt is generated every time a data word is transferred from the Receive Shift register (UxRSR) to the Receive Buffer. There may be one or more characters in the receive buffer.
- If URXISEL<1:0> = 10, an interrupt is generated when a word is transferred from the Receive Shift register (UxRSR) to the Receive Buffer, which, as a result of the transfer, contains 3 characters.
- If URXISEL<1:0> = 11, an interrupt is set when a word is transferred from the Receive Shift register (UxRSR) to the Receive Buffer, which, as a result of the transfer, contains 4 characters (i.e., becomes full).

Switching between the Interrupt modes during operation is possible, though generally not advisable during normal operation.

18.5 Reception Error Handling

18.5.1 RECEIVE BUFFER OVERRUN ERROR (OERR BIT)

The OERR bit (UxSTA<1>) is set if all of the following conditions occur:

- The receive buffer is full.
- The Receive Shift register is full, but unable to transfer the character to the receive buffer.
- The Stop bit of the character in the UxRSR is detected, indicating that the UxRSR needs to transfer the character to the buffer.

Once OERR is set, no further data is shifted in UxRSR (until the OERR bit is cleared in software or a Reset occurs). The data held in UxRSR and UxRXREG remains valid.

18.5.2 FRAMING ERROR (FERR BIT)

The FERR bit (UxSTA<2>) is set if a '0' is detected instead of a Stop bit. If two Stop bits are selected, both Stop bits must be '1', otherwise FERR will be set. The read-only FERR bit is buffered along with the received data. It is cleared on any Reset.

18.5.3 PARITY ERROR (PERR BIT)

The PERR bit (UxSTA<3>) is set if the parity of the received word is incorrect. This error bit is applicable only if a Parity mode (odd or even) is selected. The read-only PERR bit is buffered along with the received data bytes. It is cleared on any Reset.

18.5.4 IDLE STATUS

When the receiver is active (i.e., between the initial detection of the Start bit and the completion of the Stop bit), the RIDLE bit (UxSTA<4>) is '0'. Between the completion of the Stop bit and detection of the next Start bit, the RIDLE bit is '1', indicating that the UART is Idle.

18.5.5 RECEIVE BREAK

The receiver will count and expect a certain number of bit times based on the values programmed in the PDSEL (UxMODE<2:1>) and STSEL (UxMODE<0>) bits.

If the break is longer than 13 bit times, the reception is considered complete after the number of bit times specified by PDSEL and STSEL. The URXDA bit is set, FERR is set, zeros are loaded into the receive FIFO, interrupts are generated, if appropriate, and the RIDLE bit is set.

When the module receives a long break signal and the receiver has detected the Start bit, the data bits and the invalid Stop bit (which sets the FERR), the receiver must wait for a valid Stop bit before looking for the next Start bit. It cannot assume that the break condition on the line is the next Start bit.

Break is regarded as a character containing all 0's, with the FERR bit set. The break character is loaded into the buffer. No further reception can occur until a Stop bit is received. Note that RIDLE goes high when the Stop bit has not been received yet.

18.6 Address Detect Mode

Setting the ADDEN bit (UxSTA<5>) enables this special mode, in which a 9th bit (URX8) value of '1' identifies the received word as an address rather than data. This mode is only applicable for 9-bit data communication. The URXISEL control bit does not have any impact on interrupt generation in this mode, since an interrupt (if enabled) will be generated every time the received word has the 9th bit set.

18.7 Loopback Mode

Setting the LPBACK bit enables this special mode in which the UxTX pin is internally connected to the UxRX pin. When configured for the Loopback mode, the UxRX pin is disconnected from the internal UART receive logic. However, the UxTX pin still functions as in a normal operation.

To select this mode:

- Configure UART for desired mode of operation.
- Set LPBACK = 1 to enable Loopback mode.
- Enable transmission as defined in [Section 18.3 "Transmitting Data"](#).

18.8 Baud Rate Generator

The UART has a 16-bit Baud Rate Generator to allow maximum flexibility in baud rate generation. The Baud Rate Generator register (UxBRG) is readable and writable. The baud rate is computed as follows:

BRG = 16-bit value held in UxBRG register
(0 through 65535)

FCY = Instruction Clock Rate (1/Tcy)

The Baud Rate is given by [Equation 18-1](#).

EQUATION 18-1: BAUD RATE

$$\text{Baud Rate} = \text{FCY} / (16 * (\text{BRG} + 1))$$

Therefore, maximum baud rate possible is:

$$\text{FCY} / 16 \text{ (if BRG} = 0\text{),}$$

and the minimum baud rate possible is:

$$\text{FCY} / (16 * 65536).$$

With a full 16-bit Baud Rate Generator, at 30 MIPS operation, the minimum baud rate achievable is 28.5 bps.

18.9 Auto-Baud Support

To allow the system to determine baud rates of received characters, the input can be optionally linked to a selected capture input. To enable this mode, the user must program the input capture module to detect the falling and rising edges of the Start bit.

18.10 UART Operation During CPU Sleep and Idle Modes

18.10.1 UART OPERATION DURING CPU SLEEP MODE

When the device enters Sleep mode, all clock sources to the module are shutdown and stay at logic '0'. If entry into Sleep mode occurs while a transmission is in progress, then the transmission is aborted. The UxTX pin is driven to logic '1'. Similarly, if entry into Sleep mode occurs while a reception is in progress, then the reception is aborted. The UxSTA, UxMODE, transmit and receive registers and buffers, and the UxBRG register are not affected by Sleep mode.

If the Wake bit (UxMODE<7>) is set before the device enters Sleep mode, then a falling edge on the UxRX pin will generate a receive interrupt. The Receive Interrupt Select Mode bit (URXISEL) has no effect for this function. If the receive interrupt is enabled, then this will wake-up the device from Sleep. The UARTEN bit must be set in order to generate a wake-up interrupt.

18.10.2 UART OPERATION DURING CPU IDLE MODE

For the UART, the USIDL bit selects if the module will stop operation when the device enters Idle mode, or whether the module will continue on Idle. If USIDL = 0, the module will continue operation during Idle mode. If USIDL = 1, the module will stop on Idle.

TABLE 18-1: UART1 REGISTER MAP⁽¹⁾

SFR Name	Addr.	Bit 15	Bit 14	Bit 13	Bit 12	Bit 11	Bit 10	Bit 9	Bit 8	Bit 7	Bit 6	Bit 5	Bit 4	Bit 3	Bit 2	Bit 1	Bit 0	Reset State
U1MODE	020C	UARTEN	—	USIDL	—	—	—	—	—	WAKE	LPBACK	ABAUD	—	—	PDSEL1	PDSEL0	STSEL	0000 0000 0000 0000
U1STA	020E	UTXISEL	—	—	—	UTXBRK	UTXEN	UTXBF	TRMT	URXISEL1	URXISEL0	ADDEN	RIDLE	PERR	FERR	OERR	URXDA	0000 0001 0001 0000
U1TXREG	0210	—	—	—	—	—	—	—	UTX8	Transmit Register								0000 000u uuuu uuuu
U1RXREG	0212	—	—	—	—	—	—	—	URX8	Receive Register								0000 0000 0000 0000
U1BRG	0214	Baud Rate Generator Prescaler																0000 0000 0000 0000

Legend: u = uninitialized bit; — = unimplemented bit, read as '0'

Note 1: Refer to the “dsPIC30F Family Reference Manual” (DS70046) for descriptions of register bit fields.

dsPIC30F5015/5016

NOTES:

19.0 CAN MODULE

Note: This data sheet summarizes features of this group of dsPIC30F devices and is not intended to be a complete reference source. For more information on the CPU, peripherals, register descriptions and general device functionality, refer to the “dsPIC30F Family Reference Manual” (DS70046). For more information on the device instruction set and programming, refer to the “16-bit MCU and DSC Programmer’s Reference Manual” (DS70157).

19.1 Overview

The Controller Area Network (CAN) module is a serial interface, useful for communicating with other CAN modules or microcontroller devices. This interface/protocol was designed to allow communications within noisy environments. Only one CAN module is available.

The CAN module is a communication controller implementing the CAN 2.0 A/B protocol, as defined in the BOSCH specification. The module will support CAN 1.2, CAN 2.0A, CAN 2.0B Passive and CAN 2.0B Active versions of the protocol. The module implementation is a full CAN system. The CAN specification is not covered within this data sheet. The reader may refer to the BOSCH CAN specification for further details.

The module features are as follows:

- Implementation of the CAN protocol CAN 1.2, CAN 2.0A and CAN 2.0B
- Standard and extended data frames
- 0-8 bytes data length
- Programmable bit rate up to 1 Mbit/sec
- Support for remote frames
- Double-buffered receiver with two prioritized received message storage buffers (each buffer may contain up to 8 bytes of data)
- Six full (standard/extended identifier) acceptance filters, two associated with the high priority receive buffer, and four associated with the low priority receive buffer
- Two full acceptance filter masks, one each associated with the high and low priority receive buffers
- Three transmit buffers with application specified prioritization and abort capability (each buffer may contain up to 8 bytes of data)
- Programmable wake-up functionality with integrated low pass filter
- Programmable Loopback mode supports self-test operation
- Signaling via interrupt capabilities for all CAN receiver and transmitter error states

- Programmable clock source
- Programmable link to timer module for time-stamping and network synchronization
- Low-power Sleep and Idle mode

The CAN bus module consists of a protocol engine, and message buffering/control. The CAN protocol engine handles all functions for receiving and transmitting messages on the CAN bus. Messages are transmitted by first loading the appropriate data registers. Status and errors can be checked by reading the appropriate registers. Any message detected on the CAN bus is checked for errors and then matched against filters to see if it should be received and stored in one of the receive registers.

19.2 Frame Types

The CAN module transmits various types of frames, which include data messages or remote transmission requests initiated by the user as other frames that are automatically generated for control purposes. The following frame types are supported:

- Standard Data Frame

A Standard Data Frame is generated by a node when the node wishes to transmit data. It includes an 11-bit Standard Identifier (SID) but not an 18-bit Extended Identifier (EID).

- Extended Data Frame

An Extended Data Frame is similar to a Standard Data Frame, but includes an Extended Identifier as well.

- Remote Frame

It is possible for a destination node to request the data from the source. For this purpose, the destination node sends a Remote Frame with an identifier that matches the identifier of the required Data Frame. The appropriate data source node will then send a Data Frame as a response to this remote request.

- Error Frame

An Error Frame is generated by any node that detects a bus error. An error frame consists of two fields: an Error Flag field and an Error Delimiter field.

- Overload Frame

An Overload Frame can be generated by a node as a result of 2 conditions. First, the node detects a dominant bit during Interframe Space, which is an illegal condition. Second, due to internal conditions, the node is not yet able to start reception of the next message. A node may generate a maximum of two sequential Overload Frames to delay the start of the next message.

- Interframe Space

Interframe Space separates a proceeding frame (of whatever type) from a following Data or Remote Frame.

dsPIC30F5015/5016

FIGURE 19-1: CAN BUFFERS AND PROTOCOL ENGINE BLOCK DIAGRAM

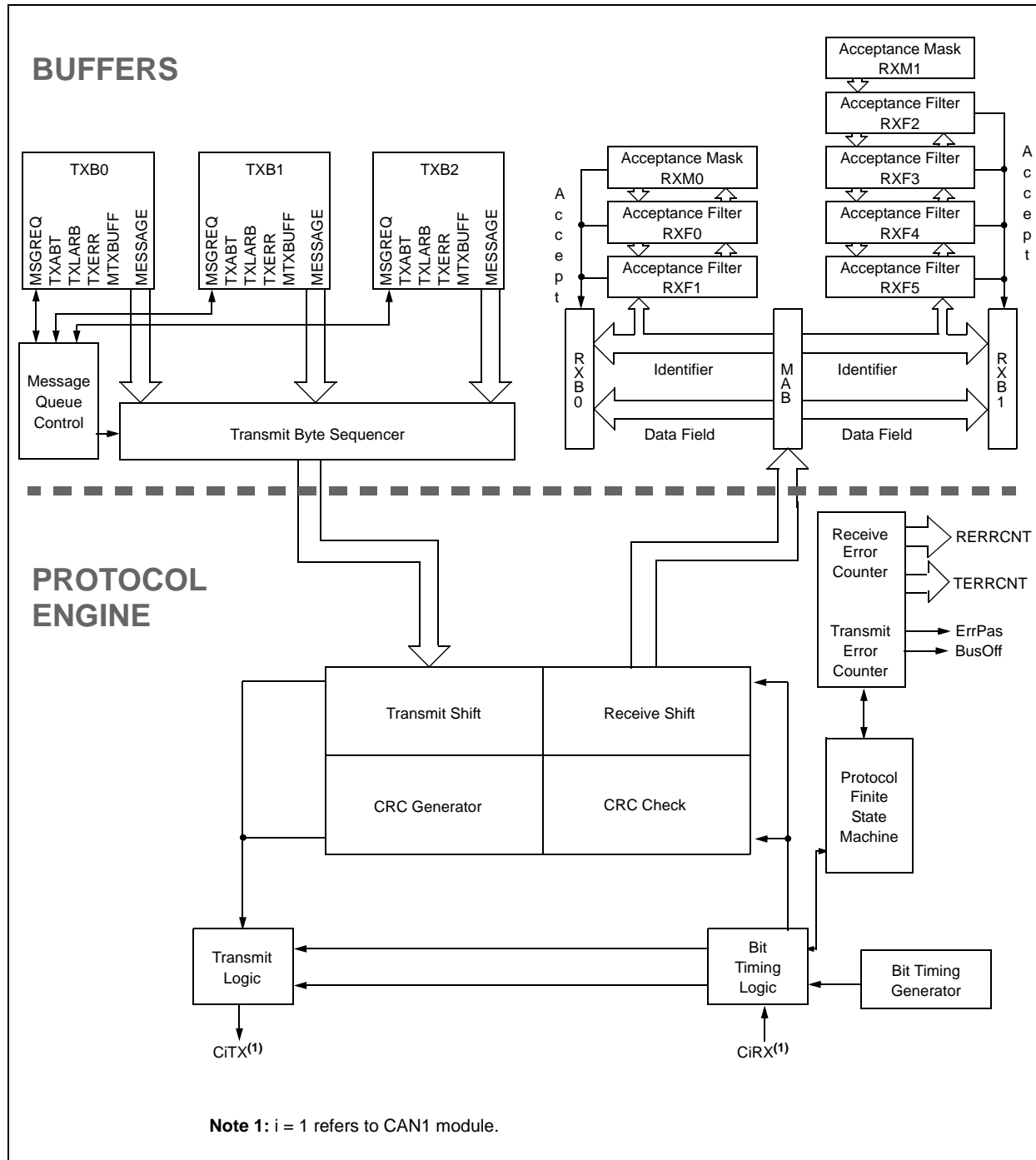

19.3 Modes of Operation

The CAN module can operate in one of several operation modes selected by the user. These modes include:

- Initialization Mode
- Disable Mode
- Normal Operation Mode
- Listen-Only Mode
- Loopback Mode
- Error Recognition Mode

Modes are requested by setting the REQOP<2:0> bits (CiCTRL<10:8>). Entry into a mode is acknowledged by monitoring the OPMODE<2:0> bits (CiCTRL<7:5>). The module will not change the mode and the OPMODE bits until a change in mode is acceptable, generally during bus idle time which is defined as at least 11 consecutive recessive bits.

19.3.1 INITIALIZATION MODE

In the Initialization mode, the module will not transmit or receive. The error counters are cleared and the interrupt flags remain unchanged. The programmer will have access to Configuration registers that are access restricted in other modes. The module will protect the user from accidentally violating the CAN protocol through programming errors. All registers which control the configuration of the module cannot be modified while the module is on-line. The CAN module will not be allowed to enter the Configuration mode while a transmission is taking place. The Configuration mode serves as a lock to protect the following registers:

- All Module Control Registers
- Baud Rate and Interrupt Configuration Registers
- Bus Timing Registers
- Identifier Acceptance Filter Registers
- Identifier Acceptance Mask Registers

19.3.2 DISABLE MODE

In Disable mode, the module will not transmit or receive. The module has the ability to set the WAKIF bit due to bus activity, however any pending interrupts will remain and the error counters will retain their value.

If the REQOP<2:0> bits (CiCTRL<10:8>) = 001, the module will enter the Module Disable mode. If the module is active, the module will wait for 11 recessive bits on the CAN bus, detect that condition as an idle bus, then accept the module disable command. When the OPMODE<2:0> bits (CiCTRL<7:5>) = 001, that indicates whether the module successfully went into Module Disable mode. The I/O pins will revert to normal I/O function when the module is in the Module Disable mode.

The module can be programmed to apply a low-pass filter function to the CiRX input line while the module or the CPU is in Sleep mode. The WAKFIL bit (CiCFG2<14>) enables or disables the filter.

Note: Typically, if the CAN module is allowed to transmit in a particular mode of operation and a transmission is requested immediately after the CAN module has been placed in that mode of operation, the module waits for 11 consecutive recessive bits on the bus before starting transmission. If the user switches to Disable mode within this 11-bit period, then this transmission is aborted and the corresponding TXABT bit is set and TXREQ bit is cleared.

19.3.3 NORMAL OPERATION MODE

Normal Operating mode is selected when REQOP<2:0> = 000. In this mode, the module is activated, the I/O pins will assume the CAN bus functions. The module will transmit and receive CAN bus messages via the CxTX and CxRX pins.

19.3.4 LISTEN-ONLY MODE

If the Listen-Only mode is activated, the module on the CAN bus is passive. The transmitter buffers revert to the Port I/O function. The receive pins remain inputs. For the receiver, no error flags or Acknowledge signals are sent. The error counters are deactivated in this state. The Listen-Only mode can be used for detecting the baud rate on the CAN bus. To use this, it is necessary that there are at least two further nodes that communicate with each other.

19.3.5 ERROR RECOGNITION MODE

The module can be set to ignore all errors and receive any message. The Error Recognition mode is activated by setting the RXM<1:0> bits (CiRXnCON<6:5>) registers to '11'. In this mode, the data which is in the message assembly buffer until the time an error occurred, is copied in the receive buffer and can be read via the CPU interface.

19.3.6 LOOPBACK MODE

If the Loopback mode is activated, the module will connect the internal transmit signal to the internal receive signal at the module boundary. The transmit and receive pins revert to their port I/O function.

19.4 Message Reception

19.4.1 RECEIVE BUFFERS

The CAN bus module has 3 receive buffers. However, one of the receive buffers is always committed to monitoring the bus for incoming messages. This buffer is called the Message Assembly Buffer (MAB). So there are 2 receive buffers visible, RXB0 and RXB1, that can essentially instantaneously receive a complete message from the protocol engine.

All messages are assembled by the MAB, and are transferred to the RXBn buffers only if the acceptance filter criterion are met. When a message is received, the RXnIF flag (CiINTF<0> or CiINRF<1>) will be set. This bit can only be set by the module when a message is received. The bit is cleared by the CPU when it has completed processing the message in the buffer. If the RXnIE bit (CiINTE<0> or CiINTE<1>) is set, an interrupt will be generated when a message is received.

RXF0 and RXF1 filters with RXM0 mask are associated with RXB0. The filters RXF2, RXF3, RXF4, and RXF5 and the mask RXM1 are associated with RXB1.

19.4.2 MESSAGE ACCEPTANCE FILTERS

The message acceptance filters and masks are used to determine if a message in the message assembly buffer should be loaded into either of the receive buffers. Once a valid message has been received into the message assembly buffer, the identifier fields of the message are compared to the filter values. If there is a match, that message will be loaded into the appropriate receive buffer.

The acceptance filter looks at incoming messages for the RXIDE bit (CiRXnSID<0>) to determine how to compare the identifiers. If the RXIDE bit is clear, the message is a standard frame, and only filters with the EXIDE bit (CiRXFnSID<0>) clear are compared. If the RXIDE bit is set, the message is an extended frame, and only filters with the EXIDE bit set are compared. Configuring the RXM<1:0> bits to '01' or '10' can override the EXIDE bit.

19.4.3 MESSAGE ACCEPTANCE FILTER MASKS

The mask bits essentially determine which bits to apply the filter to. If any mask bit is set to a zero, then that bit will automatically be accepted regardless of the filter bit. There are 2 programmable acceptance filter masks associated with the receive buffers, one for each buffer.

19.4.4 RECEIVE OVERRUN

An overrun condition occurs when the message assembly buffer has assembled a valid received message, the message is accepted through the acceptance filters, and when the receive buffer associated with the filter has not been designated as clear of the previous message.

The overrun error flag, RXnOVR (CiINTF<15> or CiINTF<14>) and the ERRIF bit (CiINTF<5>) will be set and the message in the MAB will be discarded.

If the DBEN bit is clear, RXB1 and RXB0 operate independently. When this is the case, a message intended for RXB0 will not be diverted into RXB1 if RXB0 contains an unread message and the RX0OVR bit will be set.

If the DBEN bit is set, the overrun for RXB0 is handled differently. If a valid message is received for RXB0 and RXFUL = 1 indicates that RXB0 is full and RXFUL = 0 indicates that RXB1 is empty, the message for RXB0 will be loaded into RXB1. An overrun error will not be generated for RXB0. If a valid message is received for RXB0 and RXFUL = 1 and RXFUL = 1 indicates that both RXB0 and RXB1 are full, the message will be lost and an overrun will be indicated for RXB1.

19.4.5 RECEIVE ERRORS

The CAN module will detect the following receive errors:

- Cyclic Redundancy Check (CRC) Error
- Bit Stuffing Error
- Invalid Message Receive Error

The receive error counter is incremented by one in case one of these errors occur. The RXWAR bit (CiINTF<9>) indicates that the Receive Error Counter has reached the CPU warning limit of 96 and an interrupt is generated.

19.4.6 RECEIVE INTERRUPTS

Receive interrupts can be divided into three major groups, each including various conditions that generate interrupts:

- Receive Interrupt

A message has been successfully received and loaded into one of the receive buffers. This interrupt is activated immediately after receiving the End-of-Frame (EOF) field. Reading the RXnIF flag will indicate which receive buffer caused the interrupt.

- Wake-up interrupt

The CAN module has woken up from Disable mode or the device has woken up from Sleep mode.

- Receive Error Interrupts

A receive error interrupt will be indicated by the ERRIF bit. This bit shows that an error condition occurred. The source of the error can be determined by checking the bits in the CAN Interrupt Status register, CiINTF.

- Invalid message received

If any type of error occurred during reception of the last message, an error will be indicated by the IVRIF bit.

- Receiver overrun

The RXnOVR bit indicates that an overrun condition occurred.

- Receiver warning

The RXWAR bit indicates that the Receive Error Counter (RERRCNT<7:0>) has reached the warning limit of 96.

- Receiver error passive

The RXEP bit indicates that the Receive Error Counter has exceeded the error passive limit of 127 and the module has gone into Error Passive state.

19.5 Message Transmission

19.5.1 TRANSMIT BUFFERS

The CAN module has three transmit buffers. Each of the three buffers occupies 14 bytes of data. Eight of the bytes are the maximum 8 bytes of the transmitted message. Five bytes hold the standard and extended identifiers and other message arbitration information.

19.5.2 TRANSMIT MESSAGE PRIORITY

Transmit priority is a prioritization within each node of the pending transmittable messages. There are 4 levels of transmit priority. If TXPRI<1:0> (CiTXnCON<1:0>, where n = 0, 1 or 2 represents a particular transmit buffer) for a particular message buffer is set to '11', that buffer has the highest priority. If TXPRI<1:0> for a particular message buffer is set to '10' or '01', that buffer has an intermediate priority. If TXPRI<1:0> for a particular message buffer is '00', that buffer has the lowest priority.

19.5.3 TRANSMISSION SEQUENCE

To initiate transmission of the message, the TXREQ bit (CiTXnCON<3>) must be set. The CAN bus module resolves any timing conflicts between setting of the TXREQ bit and the Start of Frame (SOF), ensuring that if the priority was changed, it is resolved correctly before the SOF occurs. When TXREQ is set, the TXABT (CiTXnCON<6>), TXLARB (CiTXnCON<5>) and TXERR (CiTXnCON<4>) flag bits are automatically cleared.

Setting the TXREQ bit simply flags a message buffer as enqueued for transmission. When the module detects an available bus, it begins transmitting the message which has been determined to have the highest priority.

If the transmission completes successfully on the first attempt, the TXREQ bit is cleared automatically and an interrupt is generated if TXIE was set.

If the message transmission fails, one of the error condition flags will be set and the TXREQ bit will remain set indicating that the message is still pending for transmission. If the message encountered an error condition during the transmission attempt, the TXERR bit will be set and the error condition may cause an interrupt. If the message loses arbitration during the transmission attempt, the TXLARB bit is set. No interrupt is generated to signal the loss of arbitration.

19.5.4 ABORTING MESSAGE TRANSMISSION

The system can also abort a message by clearing the TXREQ bit associated with each message buffer. Setting the ABAT bit (CiCTRL<12>) will request an abort of all pending messages. If the message has not yet started transmission, or if the message started but is interrupted by loss of arbitration or an error, the abort will be processed. The abort is indicated when the module sets the TXABT bit and the TXnIF flag is not automatically set.

19.5.5 TRANSMISSION ERRORS

The CAN module will detect the following transmission errors:

- Acknowledge Error
- Form Error
- Bit Error

These transmission errors will not necessarily generate an interrupt, but are indicated by the transmission error counter. However, each of these errors will cause the transmission error counter to be incremented by one. Once the value of the error counter exceeds the value of 96, the ERRIF (CiINTF<5>) and the TXWAR bit (CiINTF<10>) are set. Once the value of the error counter exceeds the value of 96, an interrupt is generated and the TXWAR bit in the Error Flag register is set.

dsPIC30F5015/5016

19.5.6 TRANSMIT INTERRUPTS

Transmit interrupts can be divided into two major groups, each including various conditions that generate interrupts:

- Transmit Interrupt

At least one of the three transmit buffers is empty (not scheduled) and can be loaded to schedule a message for transmission. Reading the TXnIF flags will indicate which transmit buffer is available and caused the interrupt.

- Transmit Error Interrupts

A transmission error interrupt will be indicated by the ERRIF flag. This flag shows that an error condition occurred. The source of the error can be determined by checking the error flags in the CAN Interrupt Status register, CiINTF. The flags in this register are related to receive and transmit errors.

- Transmitter Warning Interrupt
- The TXWAR bit indicates that the Transmit Error Counter has reached the CPU warning limit of 96
- Transmitter Error Passive
- The TXEP bit (CiINTF<12>) indicates that the Transmit Error Counter has exceeded the error passive limit of 127 and the module has gone to Error Passive state
- Bus Off
- The TXBO bit (CiINTF<13>) indicates that the Transmit Error Counter has exceeded 255 and the module has gone to Bus Off state

19.6 Baud Rate Setting

All nodes on any particular CAN bus must have the same nominal bit rate. In order to set the baud rate, the following parameters have to be initialized:

- Synchronization Jump Width
- Baud rate prescaler
- Phase segments
- Length determination of Phase2 Seg
- Sample Point
- Propagation segment bits

19.6.1 BIT TIMING

All controllers on the CAN bus must have the same baud rate and bit length. However, different controllers are not required to have the same master oscillator clock. At different clock frequencies of the individual controllers, the baud rate has to be adjusted by adjusting the number of time quanta in each segment.

The Nominal Bit Time can be thought of as being divided into separate non-overlapping time segments. These segments are shown in Figure 19-2.

- Synchronization segment (Sync Seg)
- Propagation time segment (Prop Seg)
- Phase segment 1 (Phase1 Seg)
- Phase segment 2 (Phase2 Seg)

The time segments and also the nominal bit time are made up of integer units of time called time quanta or Tq. By definition, the Nominal Bit Time has a minimum of 8 Tq and a maximum of 25 Tq. Also, by definition, the minimum nominal bit time is 1 μ sec, corresponding to a maximum bit rate of 1 MHz.

FIGURE 19-2: CAN BIT TIMING

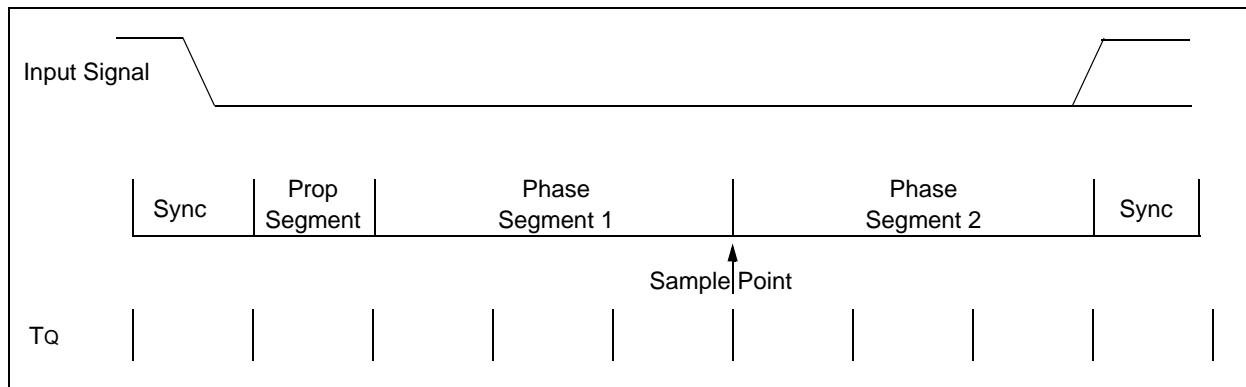

19.6.2 PRESCALER SETTING

There is a programmable prescaler, with integral values ranging from 1 to 64, in addition to a fixed divide-by-2 for clock generation. The Time Quantum (T_Q) is a fixed unit of time derived from the oscillator period, and is given by Equation 19-1, where F_{CAN} is F_{CY} (if the CANCKS bit is set or 4 F_{CY} if CANCKS is cleared).

Note: F_{CAN} must not exceed 30 MHz. If CANCKS = 0, then F_{CY} must not exceed 7.5 MHz.

EQUATION 19-1: TIME QUANTUM FOR CLOCK GENERATION

$$T_Q = 2 (BRP_{<5:0>} + 1) / F_{CAN}$$

19.6.3 PROPAGATION SEGMENT

This part of the bit time is used to compensate physical delay times within the network. These delay times consist of the signal propagation time on the bus line and the internal delay time of the nodes. The Propagation Segment can be programmed from 1 T_Q to 8 T_Q by setting the PRSEG<2:0> bits (CiCFG2<2:0>).

19.6.4 PHASE SEGMENTS

The phase segments are used to optimally locate the sampling of the received bit within the transmitted bit time. The sampling point is between Phase1 Seg and Phase2 Seg. These segments are lengthened or shortened by resynchronization. The end of the Phase1 Seg determines the sampling point within a bit period. The segment is programmable from 1 T_Q to 8 T_Q. Phase2 Seg provides delay to the next transmitted data transition. The segment is programmable from 1 T_Q to 8 T_Q, or it may be defined to be equal to the greater of Phase1 Seg or the Information Processing Time (2 T_Q). The Phase1 Seg is initialized by setting bits SEG1PH<2:0> (CiCFG2<5:3>) and Phase2 Seg is initialized by setting SEG2PH<2:0> (CiCFG2<10:8>).

The following requirement must be fulfilled while setting the lengths of the Phase Segments:

$$\text{Propagation Segment} + \text{Phase1 Seg} > \text{Phase2 Seg}$$

19.6.5 SAMPLE POINT

The sample point is the point of time at which the bus level is read and interpreted as the value of that respective bit. The location is at the end of Phase1 Seg. If the bit timing is slow and contains many T_Q, it is possible to specify multiple sampling of the bus line at the sample point. The level determined by the CAN bus then corresponds to the result from the majority decision of three values. The majority samples are taken at the sample point and twice before with a distance of T_Q/2. The CAN module allows the user to choose between sampling three times at the same point or once at the same point, by setting or clearing the SAM bit (CiCFG2<6>).

Typically, the sampling of the bit should take place at about 60-70% through the bit time, depending on the system parameters.

19.6.6 SYNCHRONIZATION

To compensate for phase shifts between the oscillator frequencies of the different bus stations, each CAN controller must be able to synchronize to the relevant signal edge of the incoming signal. When an edge in the transmitted data is detected, the logic will compare the location of the edge to the expected time (Synchronous Segment). The circuit will then adjust the values of Phase1 Seg and Phase2 Seg. There are two mechanisms used to synchronize.

19.6.6.1 Hard Synchronization

Hard Synchronization is only done whenever there is a 'recessive' to 'dominant' edge during Bus Idle, indicating the start of a message. After hard synchronization, the bit time counters are restarted with the Synchronous Segment. Hard synchronization forces the edge which has caused the hard synchronization to lie within the synchronization segment of the restarted bit time. If a hard synchronization is done, there will not be a resynchronization within that bit time.

19.6.6.2 Resynchronization

As a result of resynchronization, Phase1 Seg may be lengthened or Phase2 Seg may be shortened. The amount of lengthening or shortening of the phase buffer segment has an upper bound known as the synchronization jump width, and is specified by the SJW<1:0> bits (CiCFG1<7:6>). The value of the synchronization jump width will be added to Phase1 Seg or subtracted from Phase2 Seg. The resynchronization jump width is programmable between 1 T_Q and 4 T_Q.

The following requirement must be fulfilled while setting the SJW<1:0> bits:

$$\text{Phase2 Seg} > \text{Synchronization Jump Width}$$

TABLE 19-1: CAN1 REGISTER MAP⁽¹⁾

SFR Name	Addr.	Bit 15	Bit 14	Bit 13	Bit 12	Bit 11	Bit 10	Bit 9	Bit 8	Bit 7	Bit 6	Bit 5	Bit 4	Bit 3	Bit 2	Bit 1	Bit 0	Reset State	
C1RXF0SID	0300	—	—	—	Receive Acceptance Filter 0 Standard Identifier<10:0>											—	EXIDE	000u uuuu uuuu uu0u	
C1RXF0EIDH	0302	—	—	—	Receive Acceptance Filter 0 Extended Identifier<17:6>													0000 uuuu uuuu uuuu	
C1RXF0EIDL	0304	Receive Acceptance Filter 0 Extended Identifier<5:0>					—	—	—	—	—	—	—	—	—	—	—	—	uuuu uu00 0000 0000
C1RXF1SID	0308	—	—	—	Receive Acceptance Filter 1 Standard Identifier<10:0>											—	EXIDE	000u uuuu uuuu uu0u	
C1RXF1EIDH	030A	—	—	—	Receive Acceptance Filter 1 Extended Identifier<17:6>													0000 uuuu uuuu uuuu	
C1RXF1EIDL	030C	Receive Acceptance Filter 1 Extended Identifier<5:0>					—	—	—	—	—	—	—	—	—	—	—	—	uuuu uu00 0000 0000
C1RXF2SID	0310	—	—	—	Receive Acceptance Filter 2 Standard Identifier<10:0>											—	EXIDE	000u uuuu uuuu uu0u	
C1RXF2EIDH	0312	—	—	—	Receive Acceptance Filter 2 Extended Identifier<17:6>													0000 uuuu uuuu uuuu	
C1RXF2EIDL	0314	Receive Acceptance Filter 2 Extended Identifier<5:0>					—	—	—	—	—	—	—	—	—	—	—	—	uuuu uu00 0000 0000
C1RXF3SID	0318	—	—	—	Receive Acceptance Filter 3 Standard Identifier <10:0>											—	EXIDE	000u uuuu uuuu uu0u	
C1RXF3EIDH	031A	—	—	—	Receive Acceptance Filter 3 Extended Identifier<17:6>													0000 uuuu uuuu uuuu	
C1RXF3EIDL	031C	Receive Acceptance Filter 3 Extended Identifier<5:0>					—	—	—	—	—	—	—	—	—	—	—	—	uuuu uu00 0000 0000
C1RXF4SID	0320	—	—	—	Receive Acceptance Filter 4 Standard Identifier<10:0>											—	EXIDE	000u uuuu uuuu uu0u	
C1RXF4EIDH	0322	—	—	—	Receive Acceptance Filter 4 Extended Identifier<17:6>													0000 uuuu uuuu uuuu	
C1RXF4EIDL	0324	Receive Acceptance Filter 4 Extended Identifier<5:0>					—	—	—	—	—	—	—	—	—	—	—	—	uuuu uu00 0000 0000
C1RXF5SID	0328	—	—	—	Receive Acceptance Filter 5 Standard Identifier<10:0>											—	EXIDE	000u uuuu uuuu uu0u	
C1RXF5EIDH	032A	—	—	—	Receive Acceptance Filter 5 Extended Identifier<17:6>													0000 uuuu uuuu uuuu	
C1RXF5EIDL	032C	Receive Acceptance Filter 5 Extended Identifier<5:0>					—	—	—	—	—	—	—	—	—	—	—	—	uuuu uu00 0000 0000
C1RXM0SID	0330	—	—	—	Receive Acceptance Mask 0 Standard Identifier<10:0>											—	MIDE	000u uuuu uuuu uu0u	
C1RXM0EIDH	0332	—	—	—	Receive Acceptance Mask 0 Extended Identifier<17:6>													0000 uuuu uuuu uuuu	
C1RXM0EIDL	0334	Receive Acceptance Mask 0 Extended Identifier<5:0>					—	—	—	—	—	—	—	—	—	—	—	—	uuuu uu00 0000 0000
C1RXM1SID	0338	—	—	—	Receive Acceptance Mask 1 Standard Identifier<10:0>											—	MIDE	000u uuuu uuuu uu0u	
C1RXM1EIDH	033A	—	—	—	Receive Acceptance Mask 1 Extended Identifier<17:6>													0000 uuuu uuuu uuuu	
C1RXM1EIDL	033C	Receive Acceptance Mask 1 Extended Identifier<5:0>					—	—	—	—	—	—	—	—	—	—	—	—	uuuu uu00 0000 0000
C1TX2SID	0340	Transmit Buffer 2 Standard Identifier <10:6>					—	—	—	Transmit Buffer 2 Standard Identifier<5:0>					SRR	TXIDE	uuuu u000 uuuu uuuu		
C1TX2EID	0342	Transmit Buffer 2 Extended Identifier<17:14>					—	—	—	Transmit Buffer 2 Extended Identifier<13:6>							uuuu 0000 uuuu uuuu		
C1TX2DLC	0344	Transmit Buffer 2 Extended Identifier<5:0>					TXRTR	TXRB1	TXRB0	DLC<3:0>			—	—	—			uuuu uuuu uuuu u000	
C1TX2B1	0346	Transmit Buffer 2 Byte 1					Transmit Buffer 2 Byte 0									uuuu uuuu uuuu uuuu			
C1TX2B2	0348	Transmit Buffer 2 Byte 3					Transmit Buffer 2 Byte 2									uuuu uuuu uuuu uuuu			
C1TX2B3	034A	Transmit Buffer 2 Byte 5					Transmit Buffer 2 Byte 4									uuuu uuuu uuuu uuuu			
C1TX2B4	034C	Transmit Buffer 2 Byte 7					Transmit Buffer 2 Byte 6									uuuu uuuu uuuu uuuu			
C1TX2CON	034E	—	—	—	—	—	—	—	—	TXABT	TXLARB	TXERR	TXREQ	—	TXPRI<1:0>			0000 0000 0000 0000	
C1TX1SID	0350	Transmit Buffer 1 Standard Identifier<10:6>					—	—	—	Transmit Buffer 1 Standard Identifier<5:0>					SRR	TXIDE	uuuu u000 uuuu uuuu		
C1TX1EID	0352	Transmit Buffer 1 Extended Identifier<17:14>					—	—	—	Transmit Buffer 1 Extended Identifier<13:6>							uuuu 0000 uuuu uuuu		
C1TX1DLC	0354	Transmit Buffer 1 Extended Identifier<5:0>					TXRTR	TXRB1	TXRB0	DLC<3:0>			—	—	—			uuuu uuuu uuuu u000	
C1TX1B1	0356	Transmit Buffer 1 Byte 1					Transmit Buffer 1 Byte 0									uuuu uuuu uuuu uuuu			

Legend: u = uninitialized bit; — = unimplemented bit, read as '0'

Note 1: Refer to the "dsPIC30F Family Reference Manual" (DS70046) for descriptions of register bit fields.

TABLE 19-1: CAN1 REGISTER MAP⁽¹⁾ (CONTINUED)

SFR Name	Addr.	Bit 15	Bit 14	Bit 13	Bit 12	Bit 11	Bit 10	Bit 9	Bit 8	Bit 7	Bit 6	Bit 5	Bit 4	Bit 3	Bit 2	Bit 1	Bit 0	Reset State				
C1TX1B2	0358	Transmit Buffer 1 Byte 3							Transmit Buffer 1 Byte 2							uuuu	uuuu	uuuu	uuuu			
C1TX1B3	035A	Transmit Buffer 1 Byte 5							Transmit Buffer 1 Byte 4							uuuu	uuuu	uuuu	uuuu			
C1TX1B4	035C	Transmit Buffer 1 Byte 7							Transmit Buffer 1 Byte 6							uuuu	uuuu	uuuu	uuuu			
C1TX1CON	035E	—	—	—	—	—	—	—	—	—	TXABT	TXLARB	TXERR	TXREQ	—	TXPRI<1:0>	0000	0000	0000	0000		
C1TX0SID	0360	Transmit Buffer 0 Standard Identifier<10:6>							—	—	—	Transmit Buffer 0 Standard Identifier<5:0>					SRR	TXIDE	uuuu	u000	uuuu	uuuu
C1TX0EID	0362	Transmit Buffer 0 Extended Identifier<17:14>							—	—	—	Transmit Buffer 0 Extended Identifier<13:6>							uuuu	0000	uuuu	uuuu
C1TX0DLC	0364	Transmit Buffer 0 Extended Identifier<5:0>							TXRTR	TXRB1	TXRB0	DLC<3:0>			—	—	—	uuuu	uuuu	uuuu	u000	
C1TX0B1	0366	Transmit Buffer 0 Byte 1							Transmit Buffer 0 Byte 0							uuuu	uuuu	uuuu	uuuu			
C1TX0B2	0368	Transmit Buffer 0 Byte 3							Transmit Buffer 0 Byte 2							uuuu	uuuu	uuuu	uuuu			
C1TX0B3	036A	Transmit Buffer 0 Byte 5							Transmit Buffer 0 Byte 4							uuuu	uuuu	uuuu	uuuu			
C1TX0B4	036C	Transmit Buffer 0 Byte 7							Transmit Buffer 0 Byte 6							uuuu	uuuu	uuuu	uuuu			
C1TX0CON	036E	—	—	—	—	—	—	—	—	—	TXABT	TXLARB	TXERR	TXREQ	—	TXPRI<1:0>	0000	0000	0000	0000		
C1RX1SID	0370	—	—	—	Receive Buffer 1 Standard Identifier<10:0>											SRR	RXIDE	000u	uuuu	uuuu	uuuu	
C1RX1EID	0372	—	—	—	Receive Buffer 1 Extended Identifier<17:6>											0000	uuuu	uuuu	uuuu			
C1RX1DLC	0374	Receive Buffer 1 Extended Identifier<5:0>							RXRTR	RXRB1	—	—	—	RXRB0	DLC<3:0>			uuuu	uuuu	000u	uuuu	
C1RX1B1	0376	Receive Buffer 1 Byte 1							Receive Buffer 1 Byte 0							uuuu	uuuu	uuuu	uuuu			
C1RX1B2	0378	Receive Buffer 1 Byte 3							Receive Buffer 1 Byte 2							uuuu	uuuu	uuuu	uuuu			
C1RX1B3	037A	Receive Buffer 1 Byte 5							Receive Buffer 1 Byte 4							uuuu	uuuu	uuuu	uuuu			
C1RX1B4	037C	Receive Buffer 1 Byte 7							Receive Buffer 1 Byte 6							uuuu	uuuu	uuuu	uuuu			
C1RX1CON	037E	—	—	—	—	—	—	—	—	RXFUL	—	—	—	RXRTRRO	FILHIT<2:0>		0000	0000	0000	0000		
C1RX0SID	0380	—	—	—	Receive Buffer 0 Standard Identifier<10:0>											SRR	RXIDE	000u	uuuu	uuuu	uuuu	
C1RX0EID	0382	—	—	—	Receive Buffer 0 Extended Identifier<17:6>											0000	uuuu	uuuu	uuuu			
C1RX0DLC	0384	Receive Buffer 0 Extended Identifier<5:0>							RXRTR	RXRB1	—	—	—	RXRB0	DLC<3:0>			uuuu	uuuu	000u	uuuu	
C1RX0B1	0386	Receive Buffer 0 Byte 1							Receive Buffer 0 Byte 0							uuuu	uuuu	uuuu	uuuu			
C1RX0B2	0388	Receive Buffer 0 Byte 3							Receive Buffer 0 Byte 2							uuuu	uuuu	uuuu	uuuu			
C1RX0B3	038A	Receive Buffer 0 Byte 5							Receive Buffer 0 Byte 4							uuuu	uuuu	uuuu	uuuu			
C1RX0B4	038C	Receive Buffer 0 Byte 7							Receive Buffer 0 Byte 6							uuuu	uuuu	uuuu	uuuu			
C1RX0CON	038E	—	—	—	—	—	—	—	—	RXFUL	—	—	—	RXRTRRO	DBEN	JTOFF	FILHITO	0000	0000	0000	0000	
C1CTRL	0390	CANCAP	—	CSIDLE	ABAT	CANCKS	REQOP<2:0>			OPMODE<2:0>			—	ICODE<2:0>			—	0000	0100	1000	0000	
C1CFG1	0392	—	—	—	—	—	—	—	—	SJW<1:0>			BRP<5:0>					0000	0000	0000	0000	
C1CFG2	0394	—	WAKFIL	—	—	—	SEG2PH<2:0>			SEG2PHTS	SAM	SEG1PH<2:0>			PRSEG<2:0>			0u00	0uuu	uuuu	uuuu	
C1INTF	0396	RX0OVR	RX1OVR	TXBO	TXEP	RXEP	TXWAR	RXWAR	EWARN	IVRIF	WAKIF	ERRIF	TX2IF	TX1IF	TX0IF	RX1IF	RX0IF	0000	0000	0000	0000	
C1INTE	0398	—	—	—	—	—	—	—	—	IVRIE	WAKIE	ERRIE	TX2IE	TX1IE	TX0IE	RX1IE	RX0IE	0000	0000	0000	0000	
C1EC	039A	Transmit Error Count Register							Receive Error Count Register							0000	0000	0000	0000			

Legend: u = uninitialized bit; — = unimplemented bit, read as '0'

Note 1: Refer to the "dsPIC30F Family Reference Manual" (DS70046) for descriptions of register bit fields.

dsPIC30F5015/5016

NOTES:

20.0 10-BIT HIGH-SPEED ANALOG-TO-DIGITAL CONVERTER (ADC) MODULE

Note: This data sheet summarizes features of this group of dsPIC30F devices and is not intended to be a complete reference source. For more information on the CPU, peripherals, register descriptions and general device functionality, refer to the “dsPIC30F Family Reference Manual” (DS70046). For more information on the device instruction set and programming, refer to the “16-bit MCU and DSC Programmer’s Reference Manual” (DS70157).

The 10-bit high-speed Analog-to-Digital Converter (ADC) allows conversion of an analog input signal to a 10-bit digital number. This module is based on a Successive Approximation Register (SAR) architecture, and provides a maximum sampling rate of 1 Msps. The ADC module has 16 analog inputs which are multiplexed into four sample and hold amplifiers. The output of the sample and hold is the input into the converter, which generates the result. The analog reference voltages are software selectable to either the device supply voltage (AVDD/AVSS) or the voltage level on the (VREF+/VREF-) pin. The ADC has a unique feature of being able to operate while the device is in Sleep mode.

The ADC module has six 16-bit registers:

- A/D Control Register1 (ADCON1)
- A/D Control Register2 (ADCON2)
- A/D Control Register3 (ADCON3)
- A/D Input Select Register (ADCHS)
- A/D Port Configuration Register (ADPCFG)
- A/D Input Scan Selection Register (ADCSSL)

The ADCON1, ADCON2 and ADCON3 registers control the operation of the ADC module. The ADCHS register selects the input channels to be converted. The ADPCFG register configures the port pins as analog inputs or as digital I/O. The ADCSSL register selects inputs for scanning.

Note: The SSRC<2:0>, ASAM, SIMSAM, SMPI<3:0>, BUFM and ALTS bits, as well as the ADCON3 and ADCSSL registers, must not be written to while ADON = 1. This would lead to indeterminate results.

The block diagram of the A/D module is shown in [Figure 20-1](#).

dsPIC30F5015/5016

FIGURE 20-1: 10-BIT HIGH-SPEED A/D FUNCTIONAL BLOCK DIAGRAM

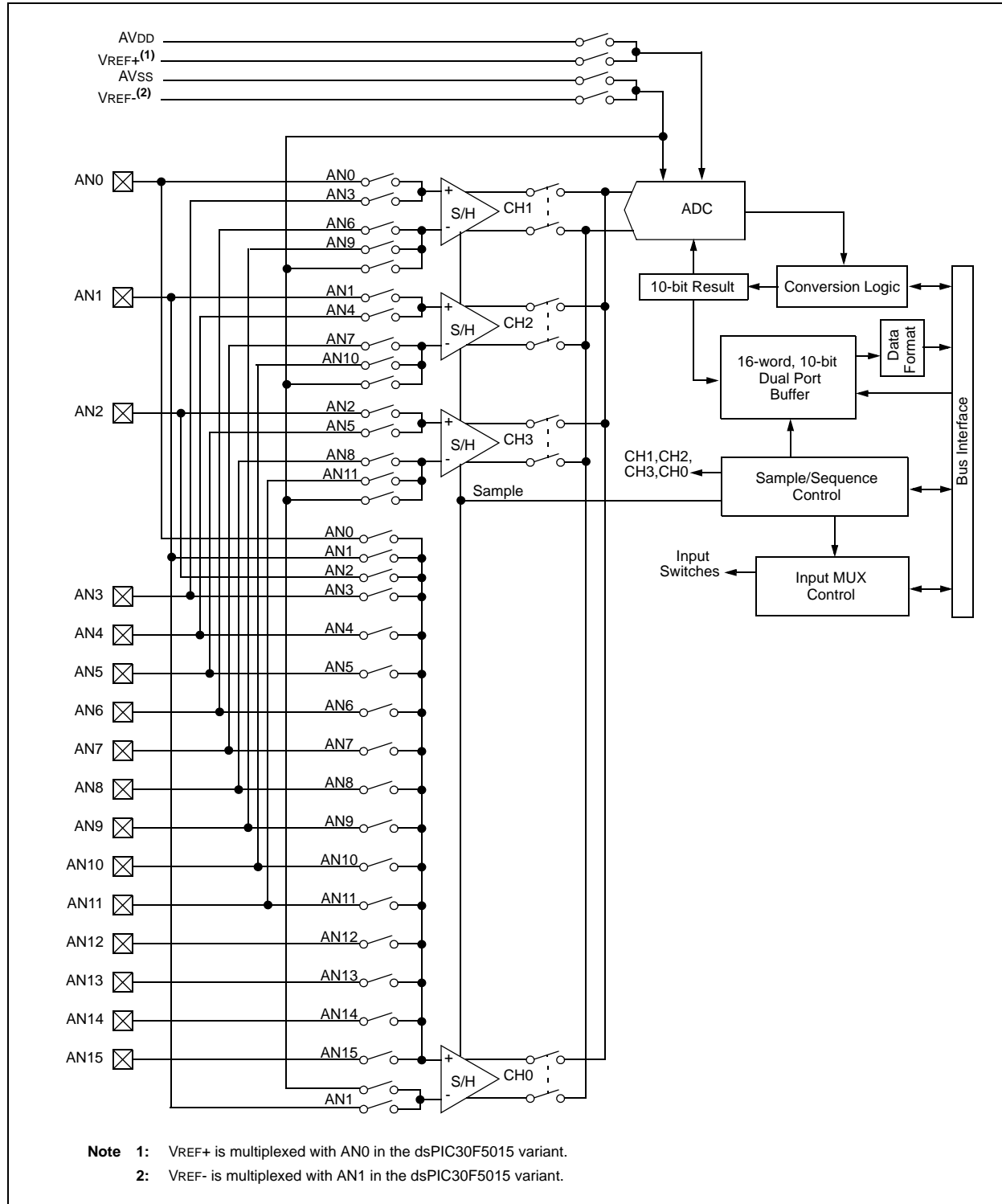

20.1 ADC Result Buffer

The module contains a 16-word dual port, read-only buffer, called ADCBUF0...ADCBUFF, to buffer the A/D results. The RAM is 10 bits wide, but is read into different format 16-bit words. The contents of the sixteen ADC Result Buffer registers, ADCBUF0 through ADCBUFF, cannot be written by user software.

20.2 Conversion Operation

After the ADC module has been configured, the sample acquisition is started by setting the SAMP bit. Various sources, such as a programmable bit, timer time-outs and external events, will terminate acquisition and start a conversion. When the A/D conversion is complete, the result is loaded into ADCBUF0...ADCBUFF, and the A/D interrupt Flag ADIF and the DONE bit are set after the number of samples specified by the SMPI bit.

The following steps should be followed for doing an A/D conversion:

1. Configure the ADC module:
 - Configure analog pins, voltage reference and digital I/O
 - Select A/D input channels
 - Select A/D conversion clock
 - Select A/D conversion trigger
 - Turn on A/D module
2. Configure A/D interrupt (if required):
 - Clear ADIF bit
 - Select A/D interrupt priority
3. Start sampling.
4. Wait the required acquisition time.
5. Trigger acquisition end, start conversion
6. Wait for A/D conversion to complete, by either:
 - Waiting for the A/D interrupt
 - Waiting for the DONE bit to get set
7. Read A/D result buffer, clear ADIF if required.

20.3 Selecting the Conversion Sequence

Several groups of control bits select the sequence in which the A/D connects inputs to the sample/hold channels, converts channels, writes the buffer memory, and generates interrupts. The sequence is controlled by the sampling clocks.

The SIMSAM bit controls the acquire/convert sequence for multiple channels. If the SIMSAM bit is '0', the two or four selected channels are acquired and converted sequentially, with two or four sample clocks. If the SIMSAM bit is '1', two or four selected channels are acquired simultaneously, with one sample clock. The channels are then converted sequentially. Obviously, if there is only 1 channel selected, the SIMSAM bit is not applicable.

The CHPS bits selects how many channels are sampled. This can vary from 1, 2 or 4 channels. If CHPS selects 1 channel, the CH0 channel will be sampled at the sample clock and converted. The result is stored in the buffer. If CHPS selects 2 channels, the CH0 and CH1 channels will be sampled and converted. If CHPS selects 4 channels, the CH0, CH1, CH2 and CH3 channels will be sampled and converted.

The SMPI bits select the number of acquisition/conversion sequences that would be performed before an interrupt occurs. This can vary from 1 sample per interrupt to 16 samples per interrupt.

The user cannot program a combination of CHPS and SMPI bits that specifies more than 16 conversions per interrupt, or 8 conversions per interrupt, depending on the BUFM bit. The BUFM bit, when set, will split the 16-word results buffer (ADCBUF0...ADCBUFF) into two 8-word groups. Writing to the 8-word buffers will be alternated on each interrupt event. Use of the BUFM bit will depend on how much time is available for moving data out of the buffers after the interrupt, as determined by the application.

If the processor can quickly unload a full buffer within the time it takes to acquire and convert one channel, the BUFM bit can be '0' and up to 16 conversions may be done per interrupt. The processor will have one sample and conversion time to move the sixteen conversions.

If the processor cannot unload the buffer within the acquisition and conversion time, the BUFM bit should be '1'. For example, if $SMPI<3:0> (ADCON2<5:2>) = 0111$, then eight conversions will be loaded into 1/2 of the buffer, following which an interrupt occurs. The next eight conversions will be loaded into the other 1/2 of the buffer. The processor will have the entire time between interrupts to move the eight conversions.

The ALTS bit can be used to alternate the inputs selected during the sampling sequence. The input multiplexer has two sets of sample inputs: MUX A and MUX B. If the ALTS bit is '0', only the MUX A inputs are selected for sampling. If the ALTS bit is '1' and $SMPI<3:0> = 0000$, on the first sample/convert sequence, the MUX A inputs are selected, and on the next acquire/convert sequence, the MUX B inputs are selected.

The CSCNA bit ($ADCON2<10>$) will allow the CH0 channel inputs to be alternately scanned across a selected number of analog inputs for the MUX A group. The inputs are selected by the ADCSSL register. If a particular bit in the ADCSSL register is '1', the corresponding input is selected. The inputs are always scanned from lower to higher numbered inputs, starting after each interrupt. If the number of inputs selected is greater than the number of samples taken per interrupt, the higher numbered inputs are unused.

dsPIC30F5015/5016

20.4 Programming the Start of Conversion Trigger

The conversion trigger will terminate acquisition and start the requested conversions.

The SSRC<2:0> bits select the source of the conversion trigger.

The SSRC bits provide for up to five alternate sources of conversion trigger.

When SSRC<2:0> = 000, the conversion trigger is under software control. Clearing the SAMP bit will cause the conversion trigger.

When SSRC<2:0> = 111 (Auto-Start mode), the conversion trigger is under A/D clock control. The SAMC bits select the number of A/D clocks between the start of acquisition and the start of conversion. This provides the fastest conversion rates on multiple channels. SAMC must always be at least one clock cycle.

Other trigger sources can come from timer modules, Motor Control PWM module, or external interrupts.

Note: To operate the ADC at the maximum specified conversion speed, the Auto-Convert Trigger option should be selected (SSRC = 111) and the Auto-Sample Time bits should be set to 1 TAD (SAMC = 00001). This configuration will give a total conversion period (sample + convert) of 13 TAD.

The use of any other conversion trigger will result in additional TAD cycles to synchronize the external event to the ADC.

20.5 Aborting a Conversion

Clearing the ADON bit during a conversion will abort the current conversion and stop the sampling sequencing. The ADCBUF will not be updated with the partially completed A/D conversion sample. That is, the ADCBUF will continue to contain the value of the last completed conversion (or the last value written to the ADCBUF register).

If the clearing of the ADON bit coincides with an auto-start, the clearing has a higher priority.

After the A/D conversion is aborted, a 2 TAD wait is required before the next sampling may be started by setting the SAMP bit.

If sequential sampling is specified, the A/D will continue at the next sample pulse which corresponds with the next channel converted. If simultaneous sampling is specified, the A/D will continue with the next multichannel group conversion sequence.

20.6 Selecting the A/D Conversion Clock

The A/D conversion requires 12 TAD. The source of the A/D conversion clock is software selected using a 6-bit counter. There are 64 possible options for TAD.

EQUATION 20-1: A/D CONVERSION CLOCK

$$TAD = T_{CY} * (0.5 * (ADCS<5:0> + 1))$$
$$ADCS<5:0> = 2 \frac{TAD}{T_{CY}} - 1$$

The internal RC oscillator is selected by setting the ADRC bit.

For correct A/D conversions, the A/D conversion clock (TAD) must be selected to ensure a minimum TAD time of 83.33 nsec (for VDD = 5V). Refer to [Section 24.0 “Electrical Characteristics”](#) for minimum TAD under other operating conditions.

[Example 20-1](#) shows a sample calculation for the ADCS<5:0> bits, assuming a device operating speed of 30 MIPS.

EXAMPLE 20-1: A/D CONVERSION CLOCK CALCULATION

$$TAD = 84 \text{ nsec}$$
$$T_{CY} = 33 \text{ nsec (30 MIPS)}$$

$$ADCS<5:0> = 2 \frac{TAD}{T_{CY}} - 1$$
$$= 2 \cdot \frac{84 \text{ nsec}}{33 \text{ nsec}} - 1$$
$$= 4.09$$

Therefore,
Set ADCS<5:0> = 5

$$\text{Actual TAD} = \frac{T_{CY}}{2} (ADCS<5:0> + 1)$$
$$= \frac{33 \text{ nsec}}{2} (9 + 1)$$
$$= 99 \text{ nsec}$$

20.7 ADC Speeds

The dsPIC30F 10-bit ADC specifications permit a maximum 1 Msp/s sampling rate. [Table 20-1](#) summarizes the conversion speeds for the dsPIC30F 10-bit ADC and the required operating conditions.

TABLE 20-1: 10-BIT CONVERSION RATE PARAMETERS

dsPIC30F 10-bit A/D Converter Conversion Rates						
A/D Speed	TAD Minimum	Sampling Time Min	Rs Max	VDD	Temperature	A/D Channels Configuration
Up to 1 Msps ⁽¹⁾	83.33 ns	12 TAD	500Ω	4.5V to 5.5V	-40°C to +85°C	
Up to 750 ksps ⁽¹⁾	95.24 ns	2 TAD	500Ω	4.5V to 5.5V	-40°C to +85°C	
Up to 600 ksps ⁽¹⁾	138.89 ns	12 TAD	500Ω	3.0V to 5.5V	-40°C to +125°C	
Up to 500 ksps	153.85 ns	1 TAD	5.0 kΩ	4.5V to 5.5V	-40°C to +125°C	
Up to 300 ksps	256.41 ns	1 TAD	5.0 kΩ	3.0V to 5.5V	-40°C to +125°C	

Note 1: External VREF- and VREF+ pins must be used for correct operation. See Figure 20-2 for recommended circuit.

dsPIC30F5015/5016

The configuration guidelines give the required setup values for the conversion speeds above 500 ksp/s, since they require external VREF pins usage and there are some differences in the configuration procedure. Configuration details that are not critical to the conversion speed have been omitted.

The following figure depicts the recommended circuit for the conversion rates above 500 ksp/s.

FIGURE 20-2: ADC VOLTAGE REFERENCE SCHEMATIC

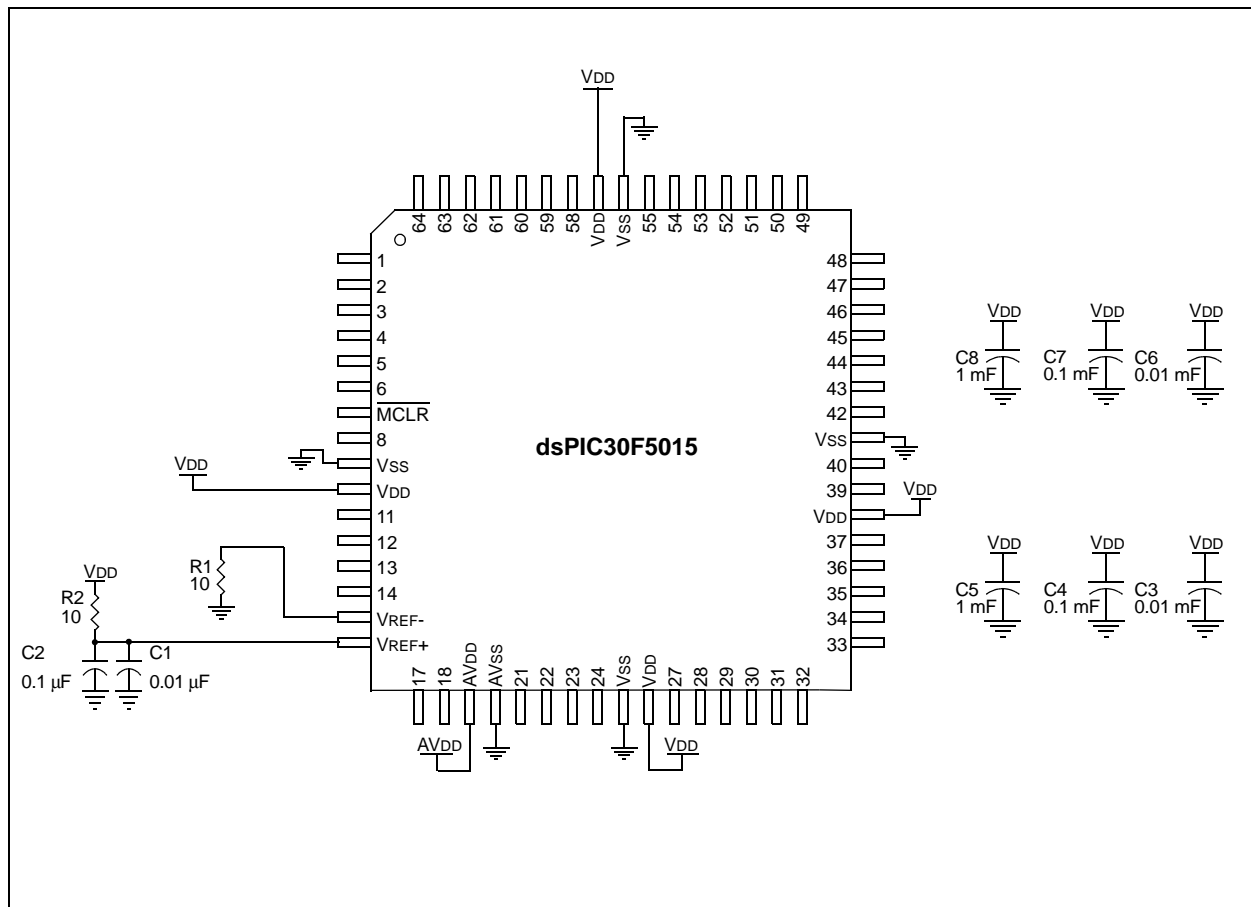

20.7.1 1 Msp/s CONFIGURATION GUIDELINE

The configuration for 1 Msp/s operation is dependent on whether a single input pin is to be sampled or whether multiple pins will be sampled.

20.7.1.1 Single Analog Input

For conversions at 1 Msp/s for a single analog input, at least two sample and hold channels must be enabled. The analog input multiplexer must be configured so that the same input pin is connected to both sample and hold channels. The ADC converts the value held on one S/H channel, while the second S/H channel acquires a new input sample.

20.7.1.2 Multiple Analog Inputs

The ADC can also be used to sample multiple analog inputs using multiple sample and hold channels. In this case, the total 1 Msp/s conversion rate is divided among the different input signals. For example, four inputs can be sampled at a rate of 250 ksp/s for each signal or two inputs could be sampled at a rate of 500 ksp/s for each signal. Sequential sampling must be used in this configuration to allow adequate sampling time on each input.

20.7.1.3 1 Msps Configuration Items

The following configuration items are required to achieve a 1 Msps conversion rate.

- Comply with conditions provided in [Table 20-2](#)
- Connect external VREF+ and VREF- pins following the recommended circuit shown in [Figure 20-2](#)
- Set SSRC<2:0> = 111 in the ADCON1 register to enable the auto-convert option
- Enable automatic sampling by setting the ASAM control bit in the ADCON1 register
- Enable sequential sampling by clearing the SIMSAM bit in the ADCON1 register
- Enable at least two sample and hold channels by writing the CHPS<1:0> control bits in the ADCON2 register
- Write the SMPI<3:0> control bits in the ADCON2 register for the desired number of conversions between interrupts. At a minimum, set SMPI<3:0> = 0001 since at least two sample and hold channels should be enabled
- Configure the A/D clock period to be:

$$\frac{1}{12 \times 1,000,000} = 83.33 \text{ ns}$$

by writing to the ADCS<5:0> control bits in the ADCON3 register

- Configure the sampling time to be 2 TAD by writing: SAMC<4:0> = 00010
- Select at least two channels per analog input pin by writing to the ADCHS register

20.7.2 750 ksps CONFIGURATION GUIDELINE

The following configuration items are required to achieve a 750 ksps conversion rate. This configuration assumes that a single analog input is to be sampled.

- Comply with conditions provided in [Table 20-2](#)
- Connect external VREF+ and VREF- pins following the recommended circuit shown in [Figure 20-2](#)
- Set SSRC<2:0> = 111 in the ADCON1 register to enable the auto-convert option
- Enable automatic sampling by setting the ASAM control bit in the ADCON1 register
- Enable one sample and hold channel by setting CHPS<1:0> = 00 in the ADCON2 register
- Write the SMPI<3:0> control bits in the ADCON2 register for the desired number of conversions between interrupts
- Configure the A/D clock period to be:

$$\frac{1}{(12 + 2) \times 750,000} = 95.24 \text{ ns}$$

by writing to the ADCS<5:0> control bits in the ADCON3 register

- Configure the sampling time to be 2 TAD by writing: SAMC<4:0> = 00010
- Select one channel per analog input pin by writing to the ADCHS register

20.7.3 600 ksps CONFIGURATION GUIDELINE

The configuration for 600 ksps operation is dependent on whether a single input pin is to be sampled or whether multiple pins will be sampled.

20.7.3.1 Single Analog Input

When performing conversions at 600 ksps for a single analog input, at least two sample and hold channels must be enabled. The analog input multiplexer must be configured so that the same input pin is connected to both sample and hold channels. The ADC the value held on one S/H channel, while the second S/H channel acquires a new input sample.

20.7.3.2 Multiple Analog Input

The ADC can also be used to sample multiple analog inputs using multiple sample and hold channels. In this case, the total 600 ksps conversion rate is divided among the different input signals. For example, four inputs can be sampled at a rate of 150 ksps for each signal or two inputs can be sampled at a rate of 300 ksps for each signal. Sequential sampling must be used in this configuration to allow adequate sampling time on each input.

20.7.3.3 600 ksps Configuration Items

The following configuration items are required to achieve a 600 ksps conversion rate.

- Comply with conditions provided in [Table 20-2](#)
- Connect external VREF+ and VREF- pins following the recommended circuit shown in [Figure 20-2](#)
- Set SSRC<2:0> = 111 in the ADCON1 register to enable the auto-convert option
- Enable automatic sampling by setting the ASAM control bit in the ADCON1 register
- Enable sequential sampling by clearing the SIMSAM bit in the ADCON1 register
- Enable at least two sample and hold channels by writing the CHPS<1:0> control bits in the ADCON2 register
- Write the SMPI<3:0> control bits in the ADCON2 register for the desired number of conversions between interrupts. At a minimum, set SMPI<3:0> = 0001 since at least two sample and hold channels should be enabled
- Configure the A/D clock period to be:

$$\frac{1}{12 \times 600,000} = 138.89 \text{ ns}$$

by writing to the ADCS<5:0> control bits in the ADCON3 register

- Configure the sampling time to be 2 Tad by writing: SAMC<4:0> = 00010
- Select at least two channels per analog input pin by writing to the ADCHS register

dsPIC30F5015/5016

20.8 ADC Acquisition Requirements

The analog input model of the 10-bit ADC is shown in Figure 20-3. The total sampling time for the ADC is a function of the internal amplifier settling time, device V_{DD} and the holding capacitor charge time.

For the ADC to meet its specified accuracy, the charge holding capacitor (C_{HOLD}) must be allowed to fully charge to the voltage level on the analog input pin. The analog output source impedance (R_S), the interconnect impedance (R_{IC}), and the internal sampling switch (R_{SS}) impedance combine to directly affect the time required to charge the capacitor C_{HOLD} . The combined impedance must therefore be small enough to fully charge the holding capacitor within the chosen sample time. To minimize the effects of pin leakage currents on the accuracy of the ADC, the maximum recommended source impedance, R_S , is 5 k Ω for conversion rates up to 500 ksp/s and a maximum of 500 Ω for conversion rates up to 1 Msp/s. After the analog input channel is selected (changed), this sampling function must be completed prior to starting the conversion. The internal holding capacitor will be in a discharged state prior to each sample operation.

The user must allow at least 1 TAD period of sampling time, T_{SAMP} , between conversions to allow each sample to be acquired. This sample time may be controlled manually in software by setting/clearing the SAMP bit, or it may be automatically controlled by the ADC. In an automatic configuration, the user must allow enough time between conversion triggers so that the minimum sample time can be satisfied. Refer to Table 24-40 for TAD and sample time requirements.

FIGURE 20-3: ADC CONVERTER ANALOG INPUT MODEL

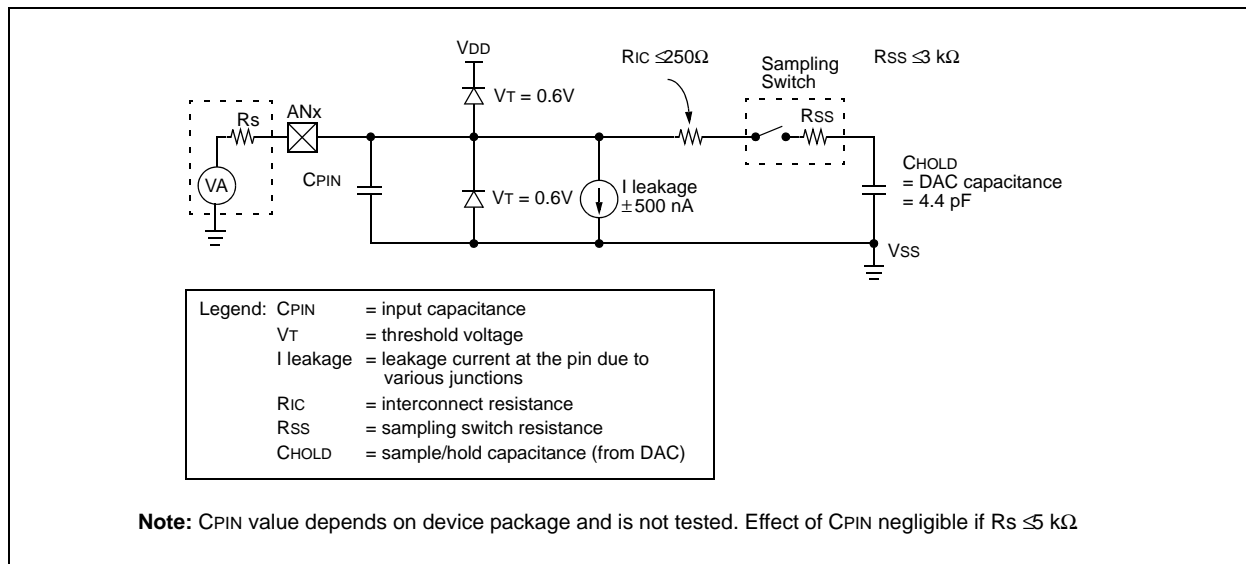

20.9 Module Power-Down Modes

The module has 3 internal power modes. When the ADON bit is '1', the module is in Active mode; it is fully powered and functional. When ADON is '0', the module is in Off mode. The digital and analog portions of the circuit are disabled for maximum current savings. In order to return to the Active mode from Off mode, the user must wait for the ADC circuitry to stabilize.

20.10 ADC Operation During CPU Sleep and Idle Modes

20.10.1 ADC OPERATION DURING CPU SLEEP MODE

When the device enters Sleep mode, all clock sources to the module are shutdown and stay at logic '0'.

If Sleep occurs in the middle of a conversion, the conversion is aborted. The converter will not continue with a partially completed conversion on exit from Sleep mode.

Register contents are not affected by the device entering or leaving Sleep mode.

The ADC module can operate during Sleep mode if the ADC clock source is set to RC (ADRC = 1). When the RC clock source is selected, the ADC module waits one instruction cycle before starting the conversion. This allows the SLEEP instruction to be executed, which eliminates all digital switching noise from the conversion. When the conversion is complete, the DONE bit will be set and the result loaded into the ADCBUF register.

If the A/D interrupt is enabled, the device will wake-up from Sleep. If the A/D interrupt is not enabled, the A/D module will then be turned off, although the ADON bit will remain set.

20.10.2 ADC OPERATION DURING CPU IDLE MODE

The ADSIDL bit selects if the module will stop on Idle or continue on Idle. If ADSIDL = 0, the module will continue operation on assertion of Idle mode. If ADSIDL = 1, the module will stop on Idle.

20.11 Effects of a Reset

A device Reset forces all registers to their Reset state. This forces the ADC module to be turned off, and any conversion and acquisition sequence is aborted. The values that are in the ADCBUF registers are not modified. The ADC result register will contain unknown data after a Power-on Reset.

20.12 Output Formats

The ADC result is 10 bits wide. The data buffer RAM is also 10 bits wide. The 10-bit data can be read in one of four different formats. The FORM<1:0> bits select the format. Each of the output formats translates to a 16-bit result on the data bus.

Write data will always be in right justified (integer) format.

FIGURE 20-4: ADC OUTPUT DATA FORMATS

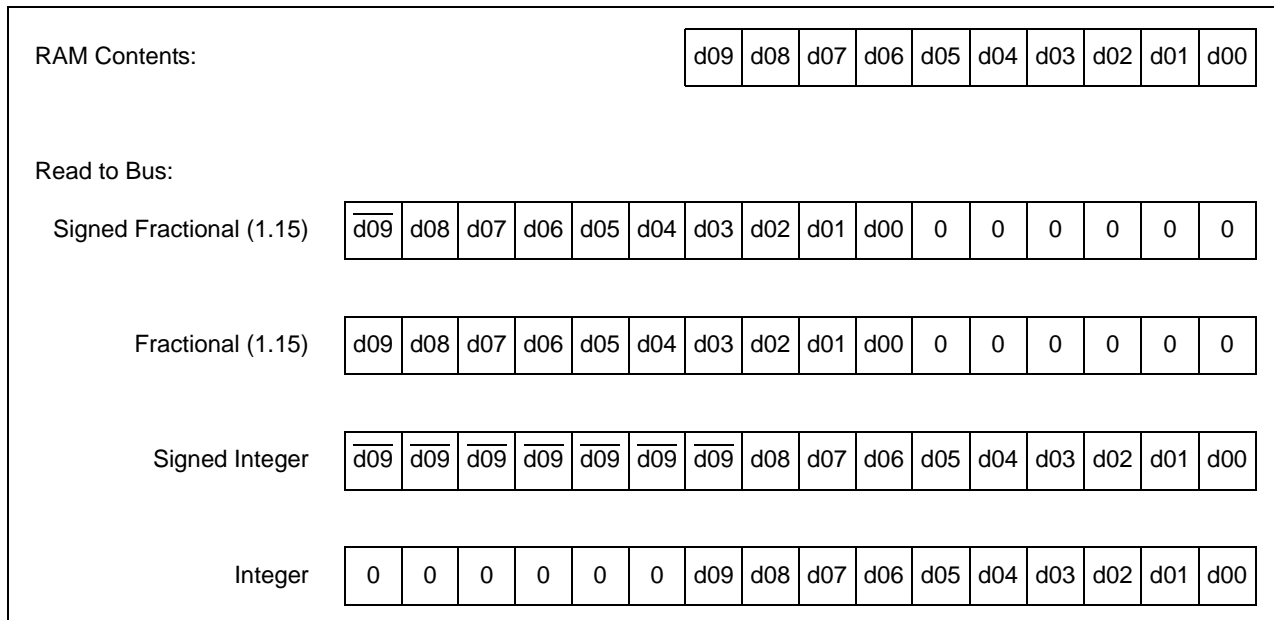

20.13 Configuring Analog Port Pins

The use of the ADPCFG and TRIS registers control the operation of the ADC port pins. The port pins that are desired as analog inputs must have their corresponding TRIS bit set (input). If the TRIS bit is cleared (output), the digital output level (VOH or VOL) will be converted.

The A/D operation is independent of the state of the CH0SA<3:0>/CH0SB<3:0> bits and the TRIS bits.

When reading the PORT register, all pins configured as analog input channels will read as cleared.

Pins configured as digital inputs will not convert an analog input. Analog levels on any pin that is defined as a digital input (including the ANx pins) may cause the input buffer to consume current that exceeds the device specifications.

20.14 Connection Considerations

The analog inputs have diodes to VDD and VSS as ESD protection. This requires that the analog input be between VDD and VSS. If the input voltage exceeds this range by greater than 0.3V (either direction), one of the diodes becomes forward biased and it may damage the device if the input current specification is exceeded.

An external RC filter is sometimes added for anti-aliasing of the input signal. The R component should be selected to ensure that the sampling time requirements are satisfied. Any external components connected (via high-impedance) to an analog input pin (capacitor, zener diode, etc.) should have very little leakage current at the pin.

TABLE 20-2: ADC REGISTER MAP⁽¹⁾

SFR Name	Addr.	Bit 15	Bit 14	Bit 13	Bit 12	Bit 11	Bit 10	Bit 9	Bit 8	Bit 7	Bit 6	Bit 5	Bit 4	Bit 3	Bit 2	Bit 1	Bit 0	Reset State
ADCBUF0	0280	—	—	—	—	—	—	ADC Data Buffer 0										0000 00uu uuuu uuuu
ADCBUF1	0282	—	—	—	—	—	—	ADC Data Buffer 1										0000 00uu uuuu uuuu
ADCBUF2	0284	—	—	—	—	—	—	ADC Data Buffer 2										0000 00uu uuuu uuuu
ADCBUF3	0286	—	—	—	—	—	—	ADC Data Buffer 3										0000 00uu uuuu uuuu
ADCBUF4	0288	—	—	—	—	—	—	ADC Data Buffer 4										0000 00uu uuuu uuuu
ADCBUF5	028A	—	—	—	—	—	—	ADC Data Buffer 5										0000 00uu uuuu uuuu
ADCBUF6	028C	—	—	—	—	—	—	ADC Data Buffer 6										0000 00uu uuuu uuuu
ADCBUF7	028E	—	—	—	—	—	—	ADC Data Buffer 7										0000 00uu uuuu uuuu
ADCBUF8	0290	—	—	—	—	—	—	ADC Data Buffer 8										0000 00uu uuuu uuuu
ADCBUF9	0292	—	—	—	—	—	—	ADC Data Buffer 9										0000 00uu uuuu uuuu
ADCBUFA	0294	—	—	—	—	—	—	ADC Data Buffer 10										0000 00uu uuuu uuuu
ADCBUFB	0296	—	—	—	—	—	—	ADC Data Buffer 11										0000 00uu uuuu uuuu
ADCBUFC	0298	—	—	—	—	—	—	ADC Data Buffer 12										0000 00uu uuuu uuuu
ADCBUFD	029A	—	—	—	—	—	—	ADC Data Buffer 13										0000 00uu uuuu uuuu
ADCBUFE	029C	—	—	—	—	—	—	ADC Data Buffer 14										0000 00uu uuuu uuuu
ADCBUFF	029E	—	—	—	—	—	—	ADC Data Buffer 15										0000 00uu uuuu uuuu
ADCON1	02A0	ADON	—	ADSIDL	—	—	—	FORM<1:0>		SSRC<2:0>		—	SIMSAM	ASAM	SAMP	DONE	0000 0000 0000 0000	
ADCON2	02A2	VCFG<2:0>			—	—	CSCNA	CHPS<1:0>		BUFS	—	SMPI<3:0>			BUFM	ALTS	0000 0000 0000 0000	
ADCON3	02A4	—	—	—	SAMC<4:0>				ADRC	—	ADCS<5:0>					0000 0000 0000 0000		
ADCHS	02A6	CH123NB<1:0>		CH123SB	CH0NB	CH0SB<3:0>			CH123NA<1:0>		CH123SA	CH0NA	CH0SA<3:0>				0000 0000 0000 0000	
ADPCFG	02A8	PCFG15	PCFG14	PCFG13	PCFG12	PCFG11	PCFG10	PCFG9	PCFG8	PCFG7	PCFG6	PCFG5	PCFG4	PCFG3	PCFG2	PCFG1	PCFG0	0000 0000 0000 0000
ADCSSL	02AA	CSSL15	CSSL14	CSSL13	CSSL12	CSSL11	CSSL10	CSSL9	CSSL8	CSSL7	CSSL6	CSSL5	CSSL4	CSSL3	CSSL2	CSSL1	CSSL0	0000 0000 0000 0000

Legend: u = uninitialized bit; — = unimplemented bit, read as '0'

Note 1: Refer to the “dsPIC30F Family Reference Manual” (DS70046) for descriptions of register bit fields.

dsPIC30F5015/5016

NOTES:

21.0 SYSTEM INTEGRATION

Note: This data sheet summarizes features of this group of dsPIC30F devices and is not intended to be a complete reference source. For more information on the CPU, peripherals, register descriptions and general device functionality, refer to the “*dsPIC30F Family Reference Manual*” (DS70046). For more information on the device instruction set and programming, refer to the “*16-bit MCU and DSC Programmer’s Reference Manual*” (DS70157).

There are several features intended to maximize system reliability, minimize cost through elimination of external components, provide power-saving operating modes and offer code protection:

- Oscillator Selection
- Reset
 - Power-on Reset (POR)
 - Power-up Timer (PWRT)
 - Oscillator Start-up Timer (OST)
 - Programmable Brown-out Reset (BOR)
- Watchdog Timer (WDT)
- Power-Saving modes (Sleep and Idle)
- Code Protection
- Unit ID Locations
- In-Circuit Serial Programming™ (ICSP™)

dsPIC30F devices have a Watchdog Timer, which is permanently enabled via the Configuration bits or can be software controlled. It runs off its own RC oscillator for added reliability. There are two timers that offer necessary delays on power-up. One is the Oscillator Start-up Timer (OST), intended to keep the chip in Reset until the crystal oscillator is stable. The other is the Power-up Timer (PWRT), which provides a delay on power-up only, designed to keep the part in Reset while the power supply stabilizes. With these two timers on-chip, most applications need no external Reset circuitry.

Sleep mode is designed to offer a very low-current Power-Down mode. The user can wake-up from Sleep through external Reset, Watchdog Timer Wake-up or through an interrupt. Several oscillator options are also made available to allow the part to fit a wide variety of applications. In the Idle mode, the clock sources are still active, but the CPU is shut-off. The RC oscillator option saves system cost, while the LP crystal option saves power.

21.1 Oscillator System Overview

The dsPIC30F oscillator system has the following modules and features:

- Various external and internal oscillator options as clock sources
- An on-chip PLL to boost internal operating frequency
- A clock switching mechanism between various clock sources
- Programmable clock postscaler for system power savings
- A Fail-Safe Clock Monitor (FSCM) that detects clock failure and takes fail-safe measures
- Clock Control register OSCCON
- Configuration bits for main oscillator selection

Configuration bits determine the clock source upon Power-on Reset (POR) and Brown-out Reset (BOR). Thereafter, the clock source can be changed between permissible clock sources. The OSCCON register controls the clock switching and reflects system clock related Status bits.

[Table 21-1](#) provides a summary of the dsPIC30F oscillator operating modes. A simplified diagram of the oscillator system is shown in [Figure 21-1](#).

dsPIC30F5015/5016

TABLE 21-1: OSCILLATOR OPERATING MODES

Oscillator Mode	Description
XTL	200 kHz-4 MHz crystal on OSC1:OSC2
XT	4 MHz-10 MHz crystal on OSC1:OSC2
XT w/PLL 4x	4 MHz-10 MHz crystal on OSC1:OSC2, 4x PLL enabled
XT w/PLL 8x	4 MHz-10 MHz crystal on OSC1:OSC2, 8x PLL enabled
XT w/PLL 16x	4 MHz-7.5 MHz crystal on OSC1:OSC2, 16x PLL enabled ⁽¹⁾
LP	32 kHz crystal on SOSCO:SOSCI ⁽²⁾
HS	10 MHz-25 MHz crystal
HS/2 w/PLL 4x	10 MHz-20 MHz crystal, divide by 2, 4x PLL enabled ⁽³⁾
HS/2 w/PLL 8x	10 MHz-20 MHz crystal, divide by 2, 8x PLL enabled ⁽³⁾
HS/2 w/PLL 16x	10 MHz-15 MHz crystal, divide by 2, 16x PLL enabled ⁽¹⁾
HS/3 w/PLL 4x	12 MHz-25 MHz crystal, divide by 3, 4x PLL enabled ⁽⁴⁾
HS/3 w/PLL 8x	12 MHz-25 MHz crystal, divide by 3, 8x PLL enabled ⁽⁴⁾
HS/3 w/PLL 16x	12 MHz-22.5 MHz crystal, divide by 3, 16x PLL enabled ⁽¹⁾⁽⁴⁾
EC	External clock input (0-40 MHz)
ECIO	External clock input (0-40 MHz), OSC2 pin is I/O
EC w/PLL 4x	External clock input (4-10 MHz), OSC2 pin is I/O, 4x PLL enabled
EC w/PLL 8x	External clock input (4-10 MHz), OSC2 pin is I/O, 8x PLL enabled
EC w/PLL 16x	External clock input (4-7.5 MHz), OSC2 pin is I/O, 16x PLL enabled ⁽¹⁾
ERC	External RC oscillator, OSC2 pin is Fosc/4 output ⁽⁵⁾
ERCIO	External RC oscillator, OSC2 pin is I/O ⁽⁵⁾
FRC	7.37 MHz internal RC oscillator
FRC w/PLL 4x	7.37 MHz internal RC oscillator, 4x PLL enabled
FRC w/PLL 8x	7.37 MHz internal RC oscillator, 8x PLL enabled
FRC w/PLL 16x	7.37 MHz internal RC oscillator, 16x PLL enabled
LPRC	512 kHz internal RC oscillator

Note 1: Any higher will violate device operating frequency range.

2: LP oscillator can be conveniently shared as system clock, as well as Real-Time Clock for Timer1.

3: Any higher will violate PLL input range.

4: Any lower will violate PLL input range.

5: Requires external R and C. Frequency operation up to 4 MHz.

FIGURE 21-1: OSCILLATOR SYSTEM BLOCK DIAGRAM

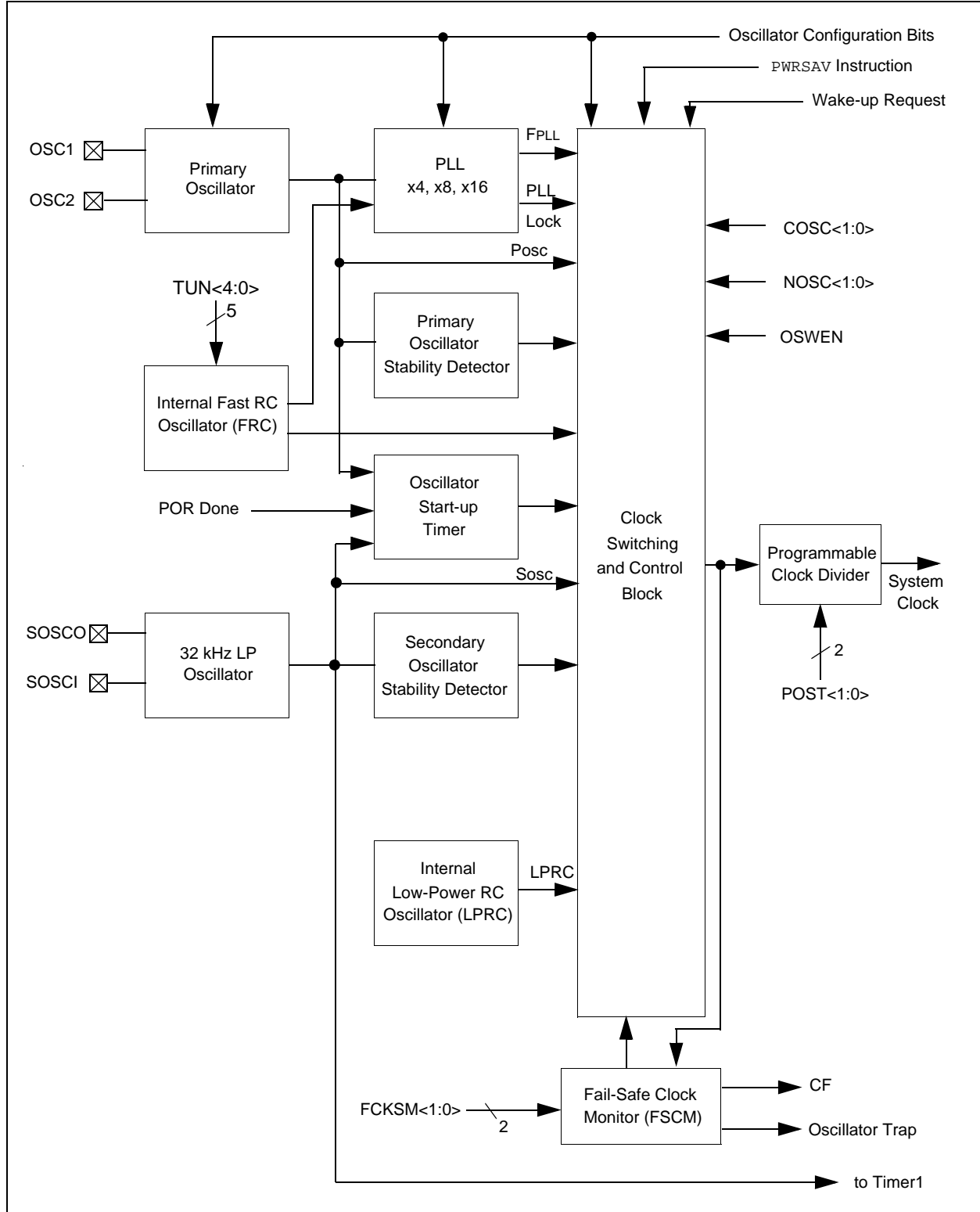

dsPIC30F5015/5016

21.2 Oscillator Configurations

21.2.1 INITIAL CLOCK SOURCE SELECTION

While coming out of Power-on Reset or Brown-out Reset, the device selects its clock source based on:

- FOS<2:0> Configuration bits that select one of four oscillator groups.
- AND FPR<4:0> Configuration bits that select one of 16 oscillator choices within the primary group.

The selection is as shown in [Table 21-2](#).

TABLE 21-2: CONFIGURATION BIT VALUES FOR CLOCK SELECTION

Oscillator Mode	Oscillator Source	FOS<2:0>			FPR<4:0>					OSC2 Function
ECIO w/PLL 4x	PLL	1	1	1	0	1	1	0	1	I/O
ECIO w/PLL 8x	PLL	1	1	1	0	1	1	1	0	I/O
ECIO w/PLL 16x	PLL	1	1	1	0	1	1	1	1	I/O
FRC w/PLL 4x	PLL	1	1	1	0	0	0	0	1	I/O
FRC w/PLL 8x	PLL	1	1	1	0	1	0	1	0	I/O
FRC w/PLL 16x	PLL	1	1	1	0	0	0	1	1	I/O
XT w/PLL 4x	PLL	1	1	1	0	0	1	0	1	OSC2
XT w/PLL 8x	PLL	1	1	1	0	0	1	1	0	OSC2
XT w/PLL 16x	PLL	1	1	1	0	0	1	1	1	OSC2
HS/2 w/PLL 4x	PLL	1	1	1	1	0	0	0	1	OSC2
HS/2 w/PLL 8x	PLL	1	1	1	1	0	0	1	0	OSC2
HS/2 w/PLL 16x	PLL	1	1	1	1	0	0	1	1	OSC2
HS/3 w/PLL 4x	PLL	1	1	1	1	0	1	0	1	OSC2
HS/3 w/PLL 8x	PLL	1	1	1	1	0	1	1	0	OSC2
HS/3 w/PLL 16x	PLL	1	1	1	1	0	1	1	1	OSC2
ECIO	External	0	1	1	0	1	1	0	0	I/O
XT	External	0	1	1	0	0	1	0	0	OSC2
HS	External	0	1	1	0	0	0	1	0	OSC2
EC	External	0	1	1	0	1	0	1	1	CLKO
ERC	External	0	1	1	0	1	0	0	1	CLKO
ERCIO	External	0	1	1	0	1	0	0	0	I/O
XTL	External	0	1	1	0	0	0	0	0	OSC2
LP	Secondary	0	0	0	x	x	x	x	x	(Note 1, 2)
FRC	Internal FRC	0	0	1	x	x	x	x	x	(Note 1, 2)
LPRC	Internal LPRC	0	1	0	x	x	x	x	x	(Note 1, 2)

Note 1: OSC2 pin function is determined by FPR<4:0>.

Note 2: OSC1 pin cannot be used as an I/O pin even if the secondary oscillator or an internal clock source is selected at all times.

21.2.2 OSCILLATOR START-UP TIMER (OST)

In order to ensure that a crystal oscillator (or ceramic resonator) has started and stabilized, an Oscillator Start-up Timer is included. It is a simple 10-bit counter that counts 1024 TOSC cycles before releasing the oscillator clock to the rest of the system. The time-out period is designated as TOST. The TOST time is involved every time the oscillator has to restart (i.e., on POR, BOR and wake-up from Sleep). The Oscillator Start-up Timer is applied to the LP, XT, XTL, and HS Oscillator modes (upon wake-up from Sleep, POR and BOR) for the primary oscillator.

21.2.3 LP OSCILLATOR CONTROL

Enabling the LP oscillator is controlled with two elements:

- The current oscillator group bits COSC<2:0>
- The LPOSCEN bit (OSCCON register)

The LP oscillator is ON (even during Sleep mode) if LPOSCEN = 1. The LP oscillator is the device clock if:

- COSC<2:0> = 000 (LP selected as main oscillator) and
- LPOSCEN = 1

Keeping the LP oscillator ON at all times allows for a fast switch to the 32 kHz system clock for lower power operation. Returning to the faster main oscillator will still require a start-up time.

21.2.4 PHASE-LOCKED LOOP (PLL)

The PLL multiplies the clock which is generated by the primary oscillator. The PLL is selectable to have either gains of x4, x8 and x16. Input and output frequency ranges are summarized in [Table 21-3](#).

TABLE 21-3: PLL FREQUENCY RANGE

Fin	PLL Multiplier	Fout
4 MHz-10 MHz	x4	16 MHz-40 MHz
4 MHz-10 MHz	x8	32 MHz-80 MHz
4 MHz-7.5 MHz	x16	64 MHz-120 MHz

The PLL features a lock output, which is asserted when the PLL enters a phase locked state. Should the loop fall out of lock (e.g., due to noise), the lock signal will be rescinded. The state of this signal is reflected in the read-only LOCK bit in the OSCCON register.

21.2.5 FAST RC OSCILLATOR (FRC)

The FRC oscillator is a fast (7.37 MHz \pm 2% nominal) internal RC oscillator. This oscillator is intended to provide reasonable device operating speeds without the use of an external crystal, ceramic resonator or RC network. The FRC oscillator can be used with the PLL to obtain higher clock frequencies.

The dsPIC30F operates from the FRC oscillator whenever the current oscillator selection control bits in the OSCCON register (OSCCON<14:12>) are set to '001'.

The 6-bit field specified by TUN<4:0> (OSCTUN<4:0>) allows the user to tune the internal fast RC oscillator (nominal 7.37 MHz). The user can tune the FRC oscillator within a range of +12.6% (930 kHz) and -13% (960 kHz) in steps of 0.4% around the factory-calibrated setting, see [Table 21-4](#).

Note: OSCTUN functionality has been provided to help customers compensate for temperature effects on the FRC frequency over a wide range of temperatures. The tuning step size is an approximation and is neither characterized nor tested.

If OSCCON<14:12> are set to '111' and FPR<4:0> are set to '00101', '00110' or '00111', then a PLL multiplier of 4, 8 or 16 (respectively) is applied.

Note: When a 16x PLL is used, the FRC oscillator must not be tuned to a frequency greater than 7.5 MHz.

TABLE 21-4: FRC TUNING

TUN<5:0> Bits	FRC Frequency
01 1111	+12.6%
01 1110	+12.2%
01 1101	+11.8%
•	•
•	•
•	•
00 0100	+1.6%
00 0011	+1.2%
00 0010	+0.8%
00 0001	+0.4%
00 0000	Center Frequency (oscillator is running at calibrated frequency)
11 1111	-0.4%
11 1110	-0.8%
11 1101	-1.2%
11 1100	-1.6%
•	•
•	•
•	•
10 0011	-11.8%
10 0010	-12.2%
10 0001	-12.6%
10 0000	-13.0%

dsPIC30F5015/5016

21.2.6 LOW-POWER RC OSCILLATOR (LPRC)

The LPRC oscillator is a component of the Watchdog Timer (WDT) and oscillates at a nominal frequency of 512 kHz. The LPRC oscillator is the clock source for the Power-up Timer (PWRT) circuit, WDT and clock monitor circuits. It may also be used to provide a low frequency clock source option for applications where power consumption is critical, and timing accuracy is not required.

The LPRC oscillator is always enabled at a Power-on Reset, because it is the clock source for the PWRT. After the PWRT expires, the LPRC oscillator will remain ON if one of the following is TRUE:

- The Fail-Safe Clock Monitor is enabled
- The WDT is enabled
- The LPRC oscillator is selected as the system clock via the COSC<2:0> control bits in the OSCCON register

If one of the above conditions is not true, the LPRC will shut-off after the PWRT expires.

Note 1: OSC2 pin function is determined by the Primary Oscillator mode selection (FPR<4:0>).

2: Note that OSC1 pin cannot be used as an I/O pin, even if the secondary oscillator or an internal clock source is selected at all times.

21.2.7 FAIL-SAFE CLOCK MONITOR

The Fail-Safe Clock Monitor (FSCM) allows the device to continue to operate even in the event of an oscillator failure. The FSCM function is enabled by appropriately programming the FCKSM Configuration bits (Clock Switch and Monitor Selection bits) in the FOSC Configuration register. If the FSCM function is enabled, the LPRC Internal oscillator will run at all times (except during Sleep mode) and will not be subject to control by the SWDTEN bit.

In the event of an oscillator failure, the FSCM will generate a clock failure trap event and will switch the system clock over to the FRC oscillator. The user will then have the option to either attempt to restart the oscillator or execute a controlled shutdown. The user may decide to treat the trap as a warm Reset by simply loading the Reset address into the oscillator fail trap vector. In this event, the CF (Clock Fail) Status bit (OSCCON<3>) is also set whenever a clock failure is recognized.

In the event of a clock failure, the WDT is unaffected and continues to run on the LPRC clock.

If the oscillator has a very slow start-up time coming out of POR, BOR or Sleep, it is possible that the PWRT timer will expire before the oscillator has started. In such cases, the FSCM will be activated and

the FSCM will initiate a clock failure trap, and the COSC<2:0> bits are loaded with FRC oscillator selection. This will effectively shut-off the original oscillator that was trying to start.

The user may detect this situation and restart the oscillator in the clock fail trap, ISR.

Upon a clock failure detection, the FSCM module will initiate a clock switch to the FRC oscillator as follows:

1. The COSC bits (OSCCON<14:12>) are loaded with the FRC oscillator selection value.
2. CF bit is set (OSCCON<3>).
3. OSWEN control bit (OSCCON<0>) is cleared.

For the purpose of clock switching, the clock sources are sectioned into four groups:

- Primary
- Secondary
- Internal FRC
- Internal LPRC

The user can switch between these functional groups, but cannot switch between options within a group. If the primary group is selected, then the choice within the group is always determined by the FPR<4:0> Configuration bits.

The OSCCON register holds the control and Status bits related to clock switching.

- COSC<2:0>: Read-only Status bits always reflect the current oscillator group in effect.
- NOSC<2:0>: Control bits which are written to indicate the new oscillator group of choice.
 - On POR and BOR, COSC<2:0> and NOSC<2:0> are both loaded with the Configuration bit values FOS<2:0>.
- LOCK: The LOCK Status bit indicates a PLL lock.
- CF: Read-only Status bit indicating if a clock fail detect has occurred.
- OSWEN: Control bit changes from a '0' to a '1' when a clock transition sequence is initiated. Clearing the OSWEN control bit will abort a clock transition in progress (used for hang-up situations).

If Configuration bits FCKSM<1:0> = 1x, then the clock switching and Fail-Safe Clock Monitor functions are disabled. This is the default Configuration bit setting.

If clock switching is disabled, then the FOS<2:0> and FPR<4:0> bits directly control the oscillator selection and the COSC<2:0> bits do not control the clock selection. However, these bits will reflect the clock source selection.

Note: The application should not attempt to switch to a clock of frequency lower than 100 kHz when the Fail-Safe Clock Monitor is enabled. If clock switching is performed, the device may generate an oscillator fail trap and switch to the Fast RC oscillator.

21.2.8 PROTECTION AGAINST ACCIDENTAL WRITES TO OSCCON

A write to the OSCCON register is intentionally made difficult because it controls clock switching and clock scaling.

To write to the OSCCON low byte, the following code sequence must be executed without any other instructions in between:

```
Byte Write 0x46 to OSCCON low
Byte Write 0x57 to OSCCON low
```

Byte write is allowed for one instruction cycle. Write the desired value or use bit manipulation instruction.

To write to the OSCCON high byte, the following instructions must be executed without any other instructions in between:

```
Byte Write 0x46 to OSCCON low
Byte Write 0x57 to OSCCON low
```

Byte write is allowed for one instruction cycle. Write the desired value or use bit manipulation instruction.

21.3 Reset

The dsPIC30F5015/5016 differentiates between various kinds of Reset:

- Power-on Reset (POR)
- $\overline{\text{MCLR}}$ Reset during normal operation
- $\overline{\text{MCLR}}$ Reset during Sleep
- Watchdog Timer (WDT) Reset (during normal operation)
- Programmable Brown-out Reset (BOR)
- RESET Instruction
- Reset cause by trap lockup (TRAPR)
- Reset caused by illegal opcode, or by using an uninitialized W register as an Address Pointer (IOPUWR)

Different registers are affected in different ways by various Reset conditions. Most registers are not affected by a WDT wake-up, since this is viewed as the resumption of normal operation. Status bits from the RCON register are set or cleared differently in different Reset situations, as indicated in Table 21-5. These bits are used in software to determine the nature of the Reset.

A block diagram of the on-chip Reset circuit is shown in Figure 21-2.

A $\overline{\text{MCLR}}$ noise filter is provided in the $\overline{\text{MCLR}}$ Reset path. The filter detects and ignores small pulses.

Internally generated Resets do not drive $\overline{\text{MCLR}}$ pin low.

21.3.1 POR: POWER-ON RESET

A power-on event will generate an internal POR pulse when a VDD rise is detected. The Reset pulse will occur at the POR circuit threshold voltage (VPOR), which is nominally 1.85V. The device supply voltage characteristics must meet specified starting voltage and rise rate requirements. The POR pulse will reset a POR timer and place the device in the Reset state. The POR also selects the device clock source identified by the oscillator configuration fuses.

The POR circuit inserts a small delay, TPOR, which is nominally 10 μs and ensures that the device bias circuits are stable. Furthermore, a user selected power-up time-out (TPWRT) is applied. The TPWRT parameter is based on Configuration bits and can be 0 ms (no delay), 4 ms, 16 ms or 64 ms. The total delay is at device power-up TPOR + TPWRT. When these delays have expired, $\overline{\text{SYSRST}}$ will be negated on the next leading edge of the Q1 clock, and the PC will jump to the Reset vector.

The timing for the $\overline{\text{SYSRST}}$ signal is shown in Figure 21-3 through Figure 21-5.

FIGURE 21-2: RESET SYSTEM BLOCK DIAGRAM

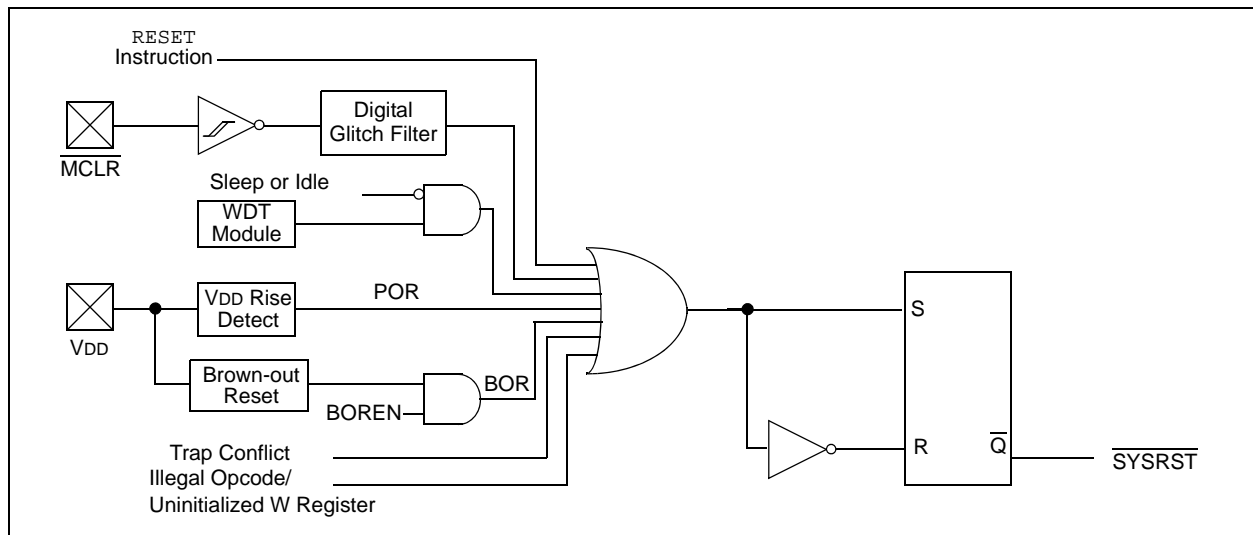

dsPIC30F5015/5016

FIGURE 21-3: TIME-OUT SEQUENCE ON POWER-UP ($\overline{\text{MCLR}}$ TIED TO V_{DD})

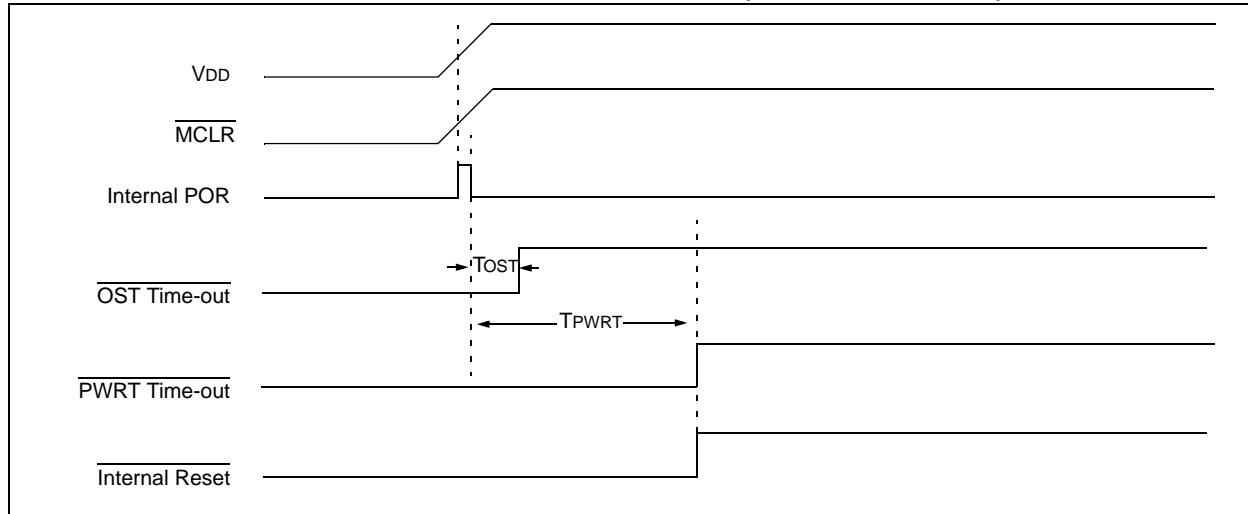

FIGURE 21-4: TIME-OUT SEQUENCE ON POWER-UP ($\overline{\text{MCLR}}$ NOT TIED TO V_{DD}): CASE 1

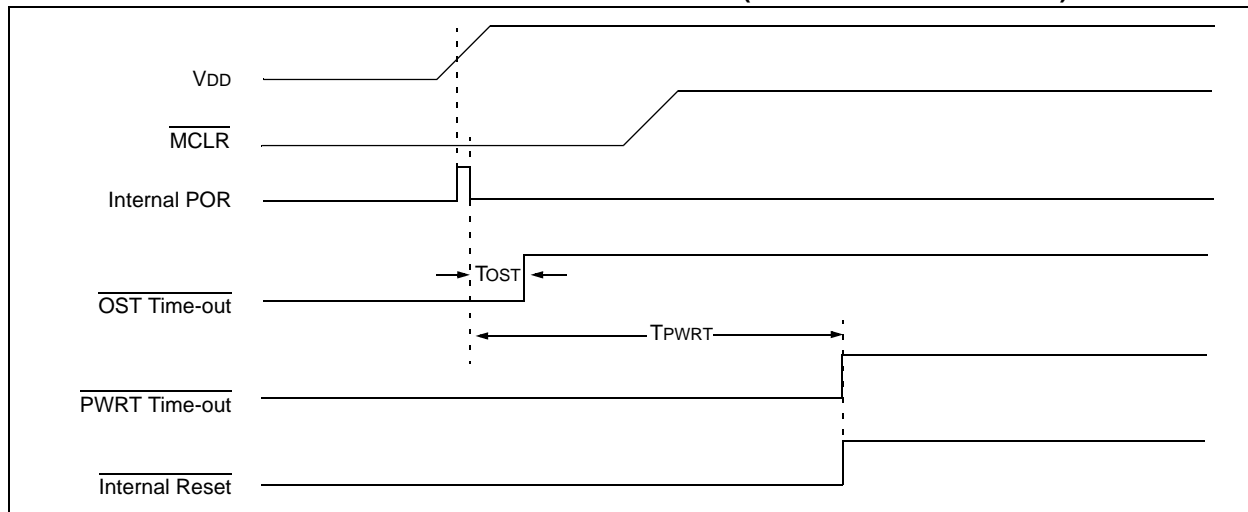
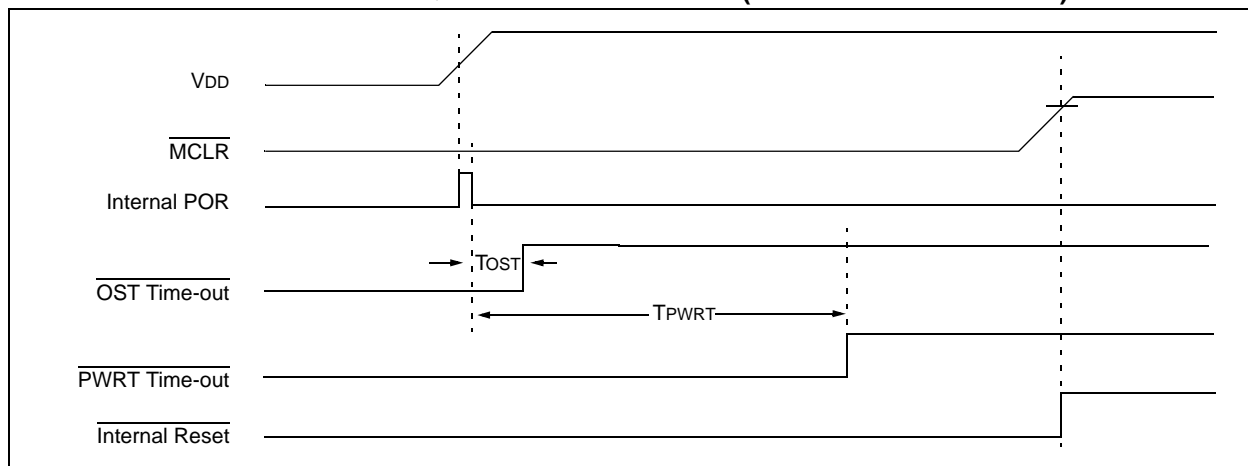

FIGURE 21-5: TIME-OUT SEQUENCE ON POWER-UP ($\overline{\text{MCLR}}$ NOT TIED TO V_{DD}): CASE 2



21.3.1.1 POR with Long Crystal Start-up Time (with FSCM Enabled)

The oscillator start-up circuitry is not linked to the POR circuitry. Some crystal circuits (especially low frequency crystals) will have a relatively long start-up time. Therefore, one or more of the following conditions is possible after the POR timer and the PWRT have expired:

- The oscillator circuit has not begun to oscillate.
- The Oscillator Start-up Timer has NOT expired (if a crystal oscillator is used).
- The PLL has not achieved a LOCK (if PLL is used).

If the FSCM is enabled and one of the above conditions is true, then a clock failure trap will occur. The device will automatically switch to the FRC oscillator and the user can switch to the desired crystal oscillator in the trap, ISR.

21.3.1.2 Operating without FSCM and PWRT

If the FSCM is disabled and the Power-up Timer (PWRT) is also disabled, then the device will exit rapidly from Reset on power-up. If the clock source is FRC, LPRC, EXTRC or EC, it will be active immediately.

If the FSCM is disabled and the system clock has not started, the device will be in a frozen state at the Reset vector until the system clock starts. From the user's perspective, the device will appear to be in Reset until a system clock is available.

21.3.2 BOR: PROGRAMMABLE BROWN-OUT RESET

The BOR (Brown-out Reset) module is based on an internal voltage reference circuit. The main purpose of the BOR module is to generate a device Reset when a brown-out condition occurs. Brown-out conditions are generally caused by glitches on the AC mains (i.e., missing portions of the AC cycle waveform due to bad power transmission lines or voltage sags due to excessive current draw when a large inductive load is turned on).

The BOR module allows selection of one of the following voltage trip points:

- 2.6V-2.71V
- 4.1V-4.4V
- 4.58V-4.73V

Note: The BOR voltage trip points indicated here are nominal values provided for design guidance only.

A BOR will generate a Reset pulse which will reset the device. The BOR will select the clock source, based on the Configuration bit values (FOS<2:0> and FPR<4:0>). Furthermore, if an oscillator mode is selected, the BOR will activate the Oscillator Start-up Timer (OST). The system clock is held until OST expires. If the PLL is used, then the clock will be held until the LOCK bit (OSCCON<5>) is '1'.

Concurrently, the POR time-out (TPOR) and the PWRT time-out (TPWRT) will be applied before the internal Reset is released. If TPWRT = 0 and a crystal oscillator is being used, then a nominal delay of $T_{FSCM} = 100 \mu s$ is applied. The total delay in this case is (TPOR + TFSCM).

The BOR Status bit (RCON<1>) will be set to indicate that a BOR has occurred. The BOR circuit, if enabled, will continue to operate while in Sleep or Idle modes and will reset the device should VDD fall below the BOR threshold voltage.

FIGURE 21-6: EXTERNAL POWER-ON RESET CIRCUIT (FOR SLOW VDD POWER-UP)

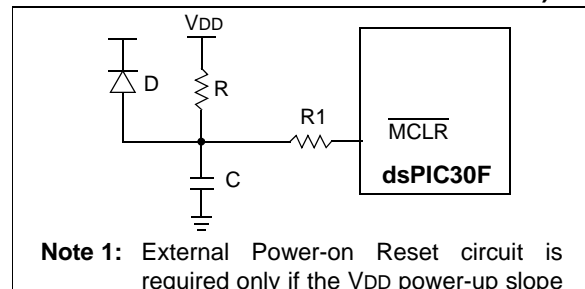

- Note 1:** External Power-on Reset circuit is required only if the VDD power-up slope is too slow. The diode D helps discharge the capacitor quickly when VDD powers down.
- 2:** R should be suitably chosen so as to make sure that the voltage drop across R does not violate the device's electrical specification.
- 3:** R1 should be suitably chosen so as to limit any current flowing into MCLR from external capacitor C, in the event of MCLR/VPP pin breakdown due to Electrostatic Discharge (ESD) or Electrical Overstress (EOS).

Note: Dedicated supervisory devices, such as the MCP1XX and MCP8XX, may also be used as an external Power-on Reset circuit.

dsPIC30F5015/5016

Table 21-5 shows the Reset conditions for the RCON register. Since the control bits within the RCON register are R/W, the information in the table implies that all the bits are negated prior to the action specified in the condition column.

TABLE 21-5: INITIALIZATION CONDITION FOR RCON REGISTER CASE 1

Condition	Program Counter	TRAPR	IOPUWR	EXTR	SWR	WDTO	IDLE	SLEEP	POR	BOR
Power-on Reset	0x000000	0	0	0	0	0	0	0	1	1
Brown-out Reset	0x000000	0	0	0	0	0	0	0	0	1
MCLR Reset during normal operation	0x000000	0	0	1	0	0	0	0	0	0
Software Reset during normal operation	0x000000	0	0	0	1	0	0	0	0	0
MCLR Reset during Sleep	0x000000	0	0	1	0	0	0	1	0	0
MCLR Reset during Idle	0x000000	0	0	1	0	0	1	0	0	0
WDT Time-out Reset	0x000000	0	0	0	0	1	0	0	0	0
WDT Wake-up	PC + 2	0	0	0	0	1	0	1	0	0
Interrupt Wake-up from Sleep	PC + 2 ⁽¹⁾	0	0	0	0	0	0	1	0	0
Clock Failure Trap	0x000004	0	0	0	0	0	0	0	0	0
Trap Reset	0x000000	1	0	0	0	0	0	0	0	0
Illegal Operation Trap	0x000000	0	1	0	0	0	0	0	0	0

Note 1: When the wake-up is due to an enabled interrupt, the PC is loaded with the corresponding interrupt vector.

Table 21-6 shows a second example of the bit conditions for the RCON register. In this case, it is not assumed the user has set/cleared specific bits prior to action specified in the condition column.

TABLE 21-6: INITIALIZATION CONDITION FOR RCON REGISTER CASE 2

Condition	Program Counter	TRAPR	IOPUWR	EXTR	SWR	WDTO	IDLE	SLEEP	POR	BOR
Power-on Reset	0x000000	0	0	0	0	0	0	0	1	1
Brown-out Reset	0x000000	u	u	u	u	u	u	u	0	1
MCLR Reset during normal operation	0x000000	u	u	1	0	0	0	0	u	u
Software Reset during normal operation	0x000000	u	u	0	1	0	0	0	u	u
MCLR Reset during Sleep	0x000000	u	u	1	u	0	0	1	u	u
MCLR Reset during Idle	0x000000	u	u	1	u	0	1	0	u	u
WDT Time-out Reset	0x000000	u	u	0	0	1	0	0	u	u
WDT Wake-up	PC + 2	u	u	u	u	1	u	1	u	u
Interrupt Wake-up from Sleep	PC + 2 ⁽¹⁾	u	u	u	u	u	u	1	u	u
Clock Failure Trap	0x000004	u	u	u	u	u	u	u	u	u
Trap Reset	0x000000	1	u	u	u	u	u	u	u	u
Illegal Operation Reset	0x000000	u	1	u	u	u	u	u	u	u

Legend: u = unchanged

Note 1: When the wake-up is due to an enabled interrupt, the PC is loaded with the corresponding interrupt vector.

21.4 Watchdog Timer (WDT)

21.4.1 WATCHDOG TIMER OPERATION

The primary function of the Watchdog Timer (WDT) is to reset the processor in the event of a software malfunction. The WDT is a free-running timer, which runs off an on-chip RC oscillator, requiring no external component. Therefore, the WDT timer will continue to operate even if the main processor clock (e.g., the crystal oscillator) fails.

21.4.2 ENABLING AND DISABLING THE WDT

The Watchdog Timer can be “enabled” or “disabled” only through a Configuration bit (FWDTEN) in the Configuration register FWDT.

Setting FWDTEN = 1 enables the Watchdog Timer. The enabling is done when programming the device. By default, after chip-erase, FWDTEN bit = 1. Any device programmer capable of programming dsPIC30F devices allows programming of this and other Configuration bits.

If enabled, the WDT will increment until it overflows or “times out”. A WDT time-out will force a device Reset (except during Sleep). To prevent a WDT time-out, the user must clear the Watchdog Timer using a CLRWDT instruction.

If a WDT times out during Sleep, the device will wake-up. The WDTO bit in the RCON register will be cleared to indicate a wake-up resulting from a WDT time-out.

Setting FWDTEN = 0 allows user software to enable/disable the Watchdog Timer via the SWDTEN (RCON<5>) control bit.

21.5 Power-Saving Modes

There are two power-saving states, Sleep and Idle, that can be entered through the execution of a special instruction, PWRSAV.

The format of the PWRSAV instruction is as follows:

PWRSAV <parameter>, where ‘parameter’ defines Idle or Sleep mode.

21.5.1 SLEEP MODE

In Sleep mode, the clock to the CPU and peripherals is shutdown. If an on-chip oscillator is being used, it is shutdown.

The Fail-Safe Clock Monitor is not functional during Sleep, since there is no clock to monitor. However, LPRC clock remains active if WDT is operational during Sleep.

The Brown-out protection circuit, if enabled, will remain functional during Sleep.

The processor wakes up from Sleep if at least one of the following conditions has occurred:

- any interrupt that is individually enabled and meets the required priority level
- any Reset (POR, BOR and MCLR)
- WDT time-out

On waking up from Sleep mode, the processor will restart the same clock that was active prior to entry into Sleep mode. When clock switching is enabled, bits COSC<2:0> will determine the oscillator source that will be used on wake-up. If clock switch is disabled, then there is only one system clock.

Note: If a POR or BOR occurred, the selection of the oscillator is based on the FOS<2:0> and FPR<4:0> Configuration bits.

If the clock source is an oscillator, the clock to the device is held off until OST times out (indicating a stable oscillator). If PLL is used, the system clock is held off until LOCK = 1 (indicating that the PLL is stable). Either way, TPOR, TLOCK and TPWRT delays are applied.

If EC, FRC, LPRC or EXTRC oscillators are used, then a delay of TPOR (~10 μs) is applied. This is the smallest delay possible on wake-up from Sleep.

Moreover, if LP oscillator was active during Sleep, and LP is the oscillator used on wake-up, then the start-up delay will be equal to TPOR. PWRT delay and OST timer delay are not applied. In order to have the smallest possible start-up delay when waking up from Sleep, one of these faster wake-up options should be selected before entering Sleep.

Any interrupt that is individually enabled (using the corresponding IE bit) and meets the prevailing priority level will be able to wake-up the processor. The processor will process the interrupt and branch to the ISR. The Sleep Status bit in RCON register is set upon wake-up.

Note: In spite of various delays applied (TPOR, TLOCK and TPWRT), the crystal oscillator (and PLL) may not be active at the end of the time-out (e.g., for low frequency crystals. In such cases), if FSCM is enabled, then the device will detect this as a clock failure and process the clock failure trap, the FRC oscillator will be enabled, and the user will have to re-enable the crystal oscillator. If FSCM is not enabled, then the device will simply suspend execution of code until the clock is stable, and will remain in Sleep until the oscillator clock has started.

All Resets will wake-up the processor from Sleep mode. Any Reset, other than POR, will set the Sleep Status bit. In a POR, the Sleep bit is cleared.

If Watchdog Timer is enabled, then the processor will wake-up from Sleep mode upon WDT time-out. The Sleep and WDTO Status bits are both set.

dsPIC30F5015/5016

21.5.2 IDLE MODE

In Idle mode, the clock to the CPU is shutdown while peripherals keep running. Unlike Sleep mode, the clock source remains active.

Several peripherals have a control bit in each module that allows them to operate during Idle.

LPRC fail-safe clock remains active if clock failure detect is enabled.

The processor wakes up from Idle if at least one of the following conditions is true:

- on any interrupt that is individually enabled (IE bit is '1') and meets the required priority level
- on any Reset (POR, BOR, MCLR)
- on WDT time-out

Upon wake-up from Idle mode, the clock is re-applied to the CPU and instruction execution begins immediately, starting with the instruction following the PWRSAV instruction.

Any interrupt that is individually enabled (using IE bit) and meets the prevailing priority level will be able to wake-up the processor. The processor will process the interrupt and branch to the ISR. The Idle Status bit in the RCON register is set upon wake-up.

Any Reset, other than POR, will set the Idle Status bit. On a POR, the Idle bit is cleared.

If Watchdog Timer is enabled, then the processor will wake-up from Idle mode upon WDT time-out. The Idle and WDTO Status bits are both set.

Unlike wake-up from Sleep, there are no time delays involved in wake-up from Idle.

21.6 Device Configuration Registers

The Configuration bits in each device Configuration register specify some of the device modes and are programmed by a device programmer, or by using the In-Circuit Serial Programming (ICSP) feature of the device. Each device Configuration register is a 24-bit register, but only the lower 16 bits of each register are used to hold configuration data. There are five Configuration registers available to the user:

1. FOSC (0xF80000): Oscillator Configuration Register
2. FWDT (0xF80002): Watchdog Timer Configuration Register
3. FBORPOR (0xF80004): BOR and POR Configuration Register
4. FGS (0xF8000A): General Code Segment Configuration Register
5. FICD (0xF8000C): Debug Configuration Register

The placement of the Configuration bits is automatically handled when you select the device in your device programmer. The desired state of the Configuration bits may be specified in the source code (dependent on the language tool used), or through the programming interface. After the device has been programmed, the application software may read the Configuration bit values through the table read instructions. For additional information, please refer to the programming specifications of the device.

<p>Note: If the code protection configuration fuse bits (FGS<GCP> and FGS<GWRP>) have been programmed, an erase of the entire code-protected device is only possible at voltages $V_{DD} \geq 4.5V$.</p>
--

21.7 Peripheral Module Disable (PMD) Registers

The Peripheral Module Disable (PMD) registers provide a method to disable a peripheral module by stopping all clock sources supplied to that module. When a peripheral is disabled via the appropriate PMD control bit, the peripheral is in a minimum power consumption state. The control and status registers associated with the peripheral will also be disabled so writes to those registers will have no effect and read values will be invalid.

A peripheral module will only be enabled if both the associated bit in the PMD register is cleared and the peripheral is supported by the specific dsPIC DSC variant. If the peripheral is present in the device, it is enabled in the PMD register by default.

Note: If a PMD bit is set, the corresponding module is disabled after a delay of 1 instruction cycle. Similarly, if a PMD bit is cleared, the corresponding module is enabled after a delay of 1 instruction cycle (assuming the module control registers are already configured to enable module operation).

21.8 In-Circuit Debugger

When MPLAB ICD 2 is selected as a debugger, the In-Circuit Debugging functionality is enabled. This function allows simple debugging functions when used with MPLAB IDE. When the device has this feature enabled, some of the resources are not available for general use. These resources include the first 80 bytes of data RAM and two I/O pins.

One of four pairs of Debug I/O pins may be selected by the user using configuration options in MPLAB IDE. These pin pairs are named EMUD/EMUC, EMUD1/EMUC1, EMUD2/EMUC2 and EMUD3/EMUC3.

In each case, the selected EMUD pin is the Emulation/Debug Data line, and the EMUC pin is the Emulation/Debug Clock line. These pins will interface to the MPLAB ICD 2 module available from Microchip. The selected pair of Debug I/O pins is used by MPLAB ICD 2 to send commands and receive responses, as well as to send and receive data. To use the In-Circuit Debugger function of the device, the design must implement ICSP connections to \overline{MCLR} , V_{DD} , V_{SS} , PGC, PGD and the selected EMUDx/EMUCx pin pair.

This gives rise to two possibilities:

1. If EMUD/EMUC is selected as the debug I/O pin pair, then only a 5-pin interface is required, as the EMUD and EMUC pin functions are multiplexed with the PGD and PGC pin functions in all dsPIC30F devices.
2. If EMUD1/EMUC1, EMUD2/EMUC2 or EMUD3/EMUC3 is selected as the debug I/O pin pair, then a 7-pin interface is required, as the EMUDx/EMUCx pin functions ($x = 1, 2$ or 3) are not multiplexed with the PGD and PGC pin functions.

TABLE 21-7: SYSTEM INTEGRATION REGISTER MAP⁽¹⁾

SFR Name	Addr.	Bit 15	Bit 14	Bit 13	Bit 12	Bit 11	Bit 10	Bit 9	Bit 8	Bit 7	Bit 6	Bit 5	Bit 4	Bit 3	Bit 2	Bit 1	Bit 0	Reset State
RCON	0740	TRAPR	IOPUWR	BGST	—	—	—	—	—	EXTR	SWR	SWDTEN	WDTO	SLEEP	IDLE	BOR	POR	Depends on type of Reset.
OSCCON	0742	—	COSC<2:0>			—	NOSC<2:0>			POST<1:0>		LOCK	—	CF	—	LPOSCEN	OSWEN	Depends on Configuration bits.
OSCTUN	0744	—	—	—	—	—	—	—	—	—	—	—	TUN<4:0>				0000 0000 0000 0000	
PMD1	0770	T5MD	T4MD	T3MD	T2MD	T1MD	QEIMD	PWMMD	—	I2CMD	U2MD	U1MD	SPI2MD	SPI1MD	—	C1MD	ADCMD	0000 0000 0000 0000
PMD2	0772	—	—	—	—	IC4MD	IC3MD	IC2MD	IC1MD	—	—	—	—	OC4MD	OC3MD	OC2MD	OC1MD	0000 0000 0000 0000

Legend: — = unimplemented bit, read as '0'

Note 1: Refer to the "dsPIC30F Family Reference Manual" (DS70046) for descriptions of register bit fields.

TABLE 21-8: DEVICE CONFIGURATION REGISTER MAP⁽¹⁾

Name	Address	Bit 15	Bit 14	Bit 13	Bit 12	Bit 11	Bit 10	Bit 9	Bit 8	Bit 7	Bit 6	Bit 5	Bit 4	Bit 3	Bit 2	Bit 1	Bit 0	
FOSC	F80000	FCKSM<1:0>			—	—	—	FOS<2:0>			—	—	—	FPR<4:0>				
FWDT	F80002	FWDTEN	—	—	—	—	—	—	—	—	—	FWPSA<1:0>		FWPSB<3:0>				
FBORPOR	F80004	MCLREN	—	—	—	—	PWMPIN	HPOL	LPOL	BOREN	—	BORV<1:0>		—	—	FPWRT<1:0>		
FBS	F80006	—	—	Reserved ⁽²⁾		—	—	—	Reserved ⁽²⁾	—	—	—	—	Reserved ⁽²⁾				
FSS	F80008	—	—	Reserved ⁽²⁾		—	—	Reserved ⁽²⁾		—	—	—	—	Reserved ⁽²⁾				
FGS	F8000A	—	—	—	—	—	—	—	—	—	—	—	—	—	—	Reserved ⁽³⁾	GCP	GWRP
FICD	F8000C	BKBUG	COE	—	—	—	—	—	—	—	—	—	—	—	—	—	ICS<1:0>	

Legend: — = unimplemented bit, read as '0'

Note 1: Refer to the "dsPIC30F Family Reference Manual" (DS70046) for descriptions of register bit fields.

Note 2: Reserved bits read as '1' and must be programmed as '1'.

Note 3: The FGS<2> bit is a read-only copy of the GCP bit (FGS<1>).

22.0 INSTRUCTION SET SUMMARY

Note: This data sheet summarizes features of this group of dsPIC30F devices and is not intended to be a complete reference source. For more information on the CPU, peripherals, register descriptions and general device functionality, refer to the “*dsPIC30F Family Reference Manual*” (DS70046). For more information on the device instruction set and programming, refer to the “*16-bit MCU and DSC Programmer’s Reference Manual*” (DS70157).

The dsPIC30F instruction set adds many enhancements to the previous PIC[®] Microcontroller (MCU) instruction sets, while maintaining an easy migration from PIC MCU instruction sets.

Most instructions are a single program memory word (24 bits). Only three instructions require two program memory locations.

Each single-word instruction is a 24-bit word divided into an 8-bit opcode which specifies the instruction type, and one or more operands which further specify the operation of the instruction.

The instruction set is highly orthogonal and is grouped into five basic categories:

- Word or byte-oriented operations
- Bit-oriented operations
- Literal operations
- DSP operations
- Control operations

Table 22-1 shows the general symbols used in describing the instructions.

The dsPIC30F instruction set summary in Table 22-2 lists all the instructions along with the status flags affected by each instruction.

Most word or byte-oriented W register instructions (including barrel shift instructions) have three operands:

- The first source operand, which is typically a register ‘Wb’ without any address modifier
- The second source operand, which is typically a register ‘Ws’ with or without an address modifier
- The destination of the result, which is typically a register ‘Wd’ with or without an address modifier

However, word or byte-oriented file register instructions have two operands:

- The file register specified by the value ‘f’
- The destination, which could either be the file register ‘f’ or the W0 register, which is denoted as ‘WREG’

Most bit oriented instructions (including simple rotate/shift instructions) have two operands:

- The W register (with or without an address modifier) or file register (specified by the value of ‘Ws’ or ‘f’)
- The bit in the W register or file register (specified by a literal value, or indirectly by the contents of register ‘Wb’)

The literal instructions that involve data movement may use some of the following operands:

- A literal value to be loaded into a W register or file register (specified by the value of ‘k’)
- The W register or file register where the literal value is to be loaded (specified by ‘Wb’ or ‘f’)

However, literal instructions that involve arithmetic or logical operations use some of the following operands:

- The first source operand, which is a register ‘Wb’ without any address modifier
- The second source operand, which is a literal value
- The destination of the result (only if not the same as the first source operand), which is typically a register ‘Wd’ with or without an address modifier

The MAC class of DSP instructions may use some of the following operands:

- The accumulator (A or B) to be used (required operand)
- The W registers to be used as the two operands
- The X and Y address space prefetch operations
- The X and Y address space prefetch destinations
- The accumulator write-back destination

The other DSP instructions do not involve any multiplication, and may include:

- The accumulator to be used (required)
- The source or destination operand (designated as Wso or Wdo, respectively) with or without an address modifier
- The amount of shift, specified by a W register ‘Wn’ or a literal value

The control instructions may use some of the following operands:

- A program memory address
- The mode of the table read and table write instructions

All instructions are a single word, except for certain double-word instructions, which were made double-word instructions so that all the required information is available in these 48 bits. In the second word, the 8 MSBs are ‘0’s. If this second word is executed as an instruction (by itself), it will execute as a NOP.

dsPIC30F5015/5016

Most single-word instructions are executed in a single instruction cycle, unless a conditional test is true or the program counter is changed as a result of the instruction. In these cases, the execution takes two instruction cycles with the additional instruction cycle(s) executed as a NOP. Notable exceptions are the BRA (unconditional/computed branch), indirect CALL/GOTO, all table reads and writes and RETURN/RETFIE instructions, which are single-word instructions, but take two or three cycles. Certain instructions that involve skipping over the subsequent instruction, require either two or

three cycles if the skip is performed, depending on whether the instruction being skipped is a single-word or two-word instruction. Moreover, double-word moves require two cycles. The double-word instructions execute in two instruction cycles.

Note: For more details on the instruction set, refer to the “16-bit MCU and DSC Programmer’s Reference Manual” (DS70157).

TABLE 22-1: SYMBOLS USED IN OPCODE DESCRIPTIONS

Field	Description
#text	Means literal defined by “text”
(text)	Means “content of text”
[text]	Means “the location addressed by text”
{ }	Optional field or operation
<n:m>	Register bit field
.b	Byte mode selection
.d	Double-word mode selection
.S	Shadow register select
.w	Word mode selection (default)
Acc	One of two accumulators {A, B}
AWB	Accumulator write-back destination address register $\in \{W13, [W13] + 2\}$
bit4	4-bit bit selection field (used in word addressed instructions) $\in \{0...15\}$
C, DC, N, OV, Z	MCU Status bits: Carry, Digit Carry, Negative, Overflow, Zero
Expr	Absolute address, label or expression (resolved by the linker)
f	File register address $\in \{0x0000...0x1FFF\}$
lit1	1-bit unsigned literal $\in \{0,1\}$
lit4	4-bit unsigned literal $\in \{0...15\}$
lit5	5-bit unsigned literal $\in \{0...31\}$
lit8	8-bit unsigned literal $\in \{0...255\}$
lit10	10-bit unsigned literal $\in \{0...255\}$ for Byte mode, $\{0:1023\}$ for Word mode
lit14	14-bit unsigned literal $\in \{0...16384\}$
lit16	16-bit unsigned literal $\in \{0...65535\}$
lit23	23-bit unsigned literal $\in \{0...8388608\}$; LSB must be ‘0’
None	Field does not require an entry, may be blank
OA, OB, SA, SB	DSP Status bits: ACCA Overflow, ACCB Overflow, ACCA Saturate, ACCB Saturate
PC	Program Counter
Slit10	10-bit signed literal $\in \{-512...511\}$
Slit16	16-bit signed literal $\in \{-32768...32767\}$
Slit6	6-bit signed literal $\in \{-16...16\}$

TABLE 22-1: SYMBOLS USED IN OPCODE DESCRIPTIONS (CONTINUED)

Field	Description
Wb	Base W register $\in \{W0..W15\}$
Wd	Destination W register $\in \{Wd, [Wd], [Wd++] , [Wd--], [++Wd], [--Wd]\}$
Wdo	Destination W register $\in \{Wnd, [Wnd], [Wnd++] , [Wnd--], [++Wnd], [--Wnd], [Wnd+Wb]\}$
Wm, Wn	Dividend, Divisor working register pair (direct addressing)
Wm*Wm	Multiplicand and Multiplier working register pair for Square instructions $\in \{W4*W4, W5*W5, W6*W6, W7*W7\}$
Wm*Wn	Multiplicand and Multiplier working register pair for DSP instructions $\in \{W4*W5, W4*W6, W4*W7, W5*W6, W5*W7, W6*W7\}$
Wn	One of 16 working registers $\in \{W0..W15\}$
Wnd	One of 16 destination working registers $\in \{W0..W15\}$
Wns	One of 16 source working registers $\in \{W0..W15\}$
WREG	W0 (working register used in file register instructions)
Ws	Source W register $\in \{Ws, [Ws], [Ws++] , [Ws--], [++Ws], [--Ws]\}$
Wso	Source W register $\in \{Wns, [Wns], [Wns++] , [Wns--], [++Wns], [--Wns], [Wns+Wb]\}$
Wx	X data space prefetch address register for DSP instructions $\in \{[W8]+ = 6, [W8]+ = 4, [W8]+ = 2, [W8], [W8]- = 6, [W8]- = 4, [W8]- = 2,$ $[W9]+ = 6, [W9]+ = 4, [W9]+ = 2, [W9], [W9]- = 6, [W9]- = 4, [W9]- = 2,$ $[W9+W12], \text{none}\}$
Wxd	X data space prefetch destination register for DSP instructions $\in \{W4..W7\}$
Wy	Y data space prefetch address register for DSP instructions $\in \{[W10]+ = 6, [W10]+ = 4, [W10]+ = 2, [W10], [W10]- = 6, [W10]- = 4, [W10]- = 2,$ $[W11]+ = 6, [W11]+ = 4, [W11]+ = 2, [W11], [W11]- = 6, [W11]- = 4, [W11]- = 2,$ $[W11+W12], \text{none}\}$
Wyd	Y data space prefetch destination register for DSP instructions $\in \{W4..W7\}$

dsPIC30F5015/5016

TABLE 22-2: INSTRUCTION SET OVERVIEW

Base Instr #	Assembly Mnemonic	Assembly Syntax	Description	# of words	# of cycles	Status Flags Affected
1	ADD	ADD <i>Acc</i>	Add Accumulators	1	1	OA,OB,SA,SB
		ADD <i>f</i>	$f = f + WREG$	1	1	C,DC,N,OV,Z
		ADD <i>f, WREG</i>	$WREG = f + WREG$	1	1	C,DC,N,OV,Z
		ADD <i>#lit10, Wn</i>	$Wd = lit10 + Wd$	1	1	C,DC,N,OV,Z
		ADD <i>Wb, Ws, Wd</i>	$Wd = Wb + Ws$	1	1	C,DC,N,OV,Z
		ADD <i>Wb, #lit5, Wd</i>	$Wd = Wb + lit5$	1	1	C,DC,N,OV,Z
2	ADDC	ADDC <i>f</i>	$f = f + WREG + (C)$	1	1	C,DC,N,OV,Z
		ADDC <i>f, WREG</i>	$WREG = f + WREG + (C)$	1	1	C,DC,N,OV,Z
		ADDC <i>#lit10, Wn</i>	$Wd = lit10 + Wd + (C)$	1	1	C,DC,N,OV,Z
		ADDC <i>Wb, Ws, Wd</i>	$Wd = Wb + Ws + (C)$	1	1	C,DC,N,OV,Z
		ADDC <i>Wb, #lit5, Wd</i>	$Wd = Wb + lit5 + (C)$	1	1	C,DC,N,OV,Z
3	AND	AND <i>f</i>	$f = f .AND. WREG$	1	1	N,Z
		AND <i>f, WREG</i>	$WREG = f .AND. WREG$	1	1	N,Z
		AND <i>#lit10, Wn</i>	$Wd = lit10 .AND. Wd$	1	1	N,Z
		AND <i>Wb, Ws, Wd</i>	$Wd = Wb .AND. Ws$	1	1	N,Z
		AND <i>Wb, #lit5, Wd</i>	$Wd = Wb .AND. lit5$	1	1	N,Z
4	ASR	ASR <i>f</i>	$f = \text{Arithmetic Right Shift } f$	1	1	C,N,OV,Z
		ASR <i>f, WREG</i>	$WREG = \text{Arithmetic Right Shift } f$	1	1	C,N,OV,Z
		ASR <i>Ws, Wd</i>	$Wd = \text{Arithmetic Right Shift } Ws$	1	1	C,N,OV,Z
		ASR <i>Wb, Wns, Wnd</i>	$Wnd = \text{Arithmetic Right Shift } Wb \text{ by } Wns$	1	1	N,Z
		ASR <i>Wb, #lit5, Wnd</i>	$Wnd = \text{Arithmetic Right Shift } Wb \text{ by } lit5$	1	1	N,Z
5	BCLR	BCLR <i>f, #bit4</i>	Bit Clear <i>f</i>	1	1	None
		BCLR <i>Ws, #bit4</i>	Bit Clear <i>Ws</i>	1	1	None
6	BRA	BRA <i>C, Expr</i>	Branch if Carry	1	1 (2)	None
		BRA <i>GE, Expr</i>	Branch if greater than or equal	1	1 (2)	None
		BRA <i>GEU, Expr</i>	Branch if unsigned greater than or equal	1	1 (2)	None
		BRA <i>GT, Expr</i>	Branch if greater than	1	1 (2)	None
		BRA <i>GTU, Expr</i>	Branch if unsigned greater than	1	1 (2)	None
		BRA <i>LE, Expr</i>	Branch if less than or equal	1	1 (2)	None
		BRA <i>LEU, Expr</i>	Branch if unsigned less than or equal	1	1 (2)	None
		BRA <i>LT, Expr</i>	Branch if less than	1	1 (2)	None
		BRA <i>LTU, Expr</i>	Branch if unsigned less than	1	1 (2)	None
		BRA <i>N, Expr</i>	Branch if Negative	1	1 (2)	None
		BRA <i>NC, Expr</i>	Branch if Not Carry	1	1 (2)	None
		BRA <i>NN, Expr</i>	Branch if Not Negative	1	1 (2)	None
		BRA <i>NOV, Expr</i>	Branch if Not Overflow	1	1 (2)	None
		BRA <i>NZ, Expr</i>	Branch if Not Zero	1	1 (2)	None
		BRA <i>OA, Expr</i>	Branch if accumulator A overflow	1	1 (2)	None
		BRA <i>OB, Expr</i>	Branch if accumulator B overflow	1	1 (2)	None
		BRA <i>OV, Expr</i>	Branch if Overflow	1	1 (2)	None
		BRA <i>SA, Expr</i>	Branch if accumulator A saturated	1	1 (2)	None
		BRA <i>SB, Expr</i>	Branch if accumulator B saturated	1	1 (2)	None
		BRA <i>Expr</i>	Branch Unconditionally	1	2	None
BRA <i>Z, Expr</i>	Branch if Zero	1	1 (2)	None		
BRA <i>Wn</i>	Computed Branch	1	2	None		
7	BSET	BSET <i>f, #bit4</i>	Bit Set <i>f</i>	1	1	None
		BSET <i>Ws, #bit4</i>	Bit Set <i>Ws</i>	1	1	None
8	BSW	BSW.C <i>Ws, Wb</i>	Write C bit to $Ws < Wb >$	1	1	None
		BSW.Z <i>Ws, Wb</i>	Write Z bit to $Ws < Wb >$	1	1	None
9	BTG	BTG <i>f, #bit4</i>	Bit Toggle <i>f</i>	1	1	None
		BTG <i>Ws, #bit4</i>	Bit Toggle <i>Ws</i>	1	1	None
10	BTSC	BTSC <i>f, #bit4</i>	Bit Test <i>f</i> , Skip if Clear	1	1 (2 or 3)	None
		BTSC <i>Ws, #bit4</i>	Bit Test <i>Ws</i> , Skip if Clear	1	1 (2 or 3)	None

TABLE 22-2: INSTRUCTION SET OVERVIEW (CONTINUED)

Base Instr #	Assembly Mnemonic	Assembly Syntax	Description	# of words	# of cycles	Status Flags Affected
11	BTSS	BTSS <i>f</i> , #bit4	Bit Test <i>f</i> , Skip if Set	1	1 (2 or 3)	None
		BTSS <i>Ws</i> , #bit4	Bit Test <i>Ws</i> , Skip if Set	1	1 (2 or 3)	None
12	BTST	BTST <i>f</i> , #bit4	Bit Test <i>f</i>	1	1	Z
		BTST.C <i>Ws</i> , #bit4	Bit Test <i>Ws</i> to C	1	1	C
		BTST.Z <i>Ws</i> , #bit4	Bit Test <i>Ws</i> to Z	1	1	Z
		BTST.C <i>Ws</i> , <i>Wb</i>	Bit Test <i>Ws</i> < <i>Wb</i> > to C	1	1	C
		BTST.Z <i>Ws</i> , <i>Wb</i>	Bit Test <i>Ws</i> < <i>Wb</i> > to Z	1	1	Z
13	BTSTS	BTSTS <i>f</i> , #bit4	Bit Test then Set <i>f</i>	1	1	Z
		BTSTS.C <i>Ws</i> , #bit4	Bit Test <i>Ws</i> to C, then Set	1	1	C
		BTSTS.Z <i>Ws</i> , #bit4	Bit Test <i>Ws</i> to Z, then Set	1	1	Z
14	CALL	CALL <i>lit</i> 23	Call subroutine	2	2	None
		CALL <i>Wn</i>	Call indirect subroutine	1	2	None
15	CLR	CLR <i>f</i>	<i>f</i> = 0x0000	1	1	None
		CLR WREG	WREG = 0x0000	1	1	None
		CLR <i>Ws</i>	<i>Ws</i> = 0x0000	1	1	None
		CLR <i>Acc</i> , <i>Wx</i> , <i>Wxd</i> , <i>Wy</i> , <i>Wyd</i> , <i>AWB</i>	Clear Accumulator	1	1	OA,OB,SA,SB
16	CLRWDT	CLRWDT	Clear Watchdog Timer	1	1	WDTO,Sleep
17	COM	COM <i>f</i>	<i>f</i> = \bar{f}	1	1	N,Z
		COM <i>f</i> , WREG	WREG = \bar{f}	1	1	N,Z
		COM <i>Ws</i> , <i>Wd</i>	<i>Wd</i> = <i>Ws</i>	1	1	N,Z
18	CP	CP <i>f</i>	Compare <i>f</i> with WREG	1	1	C,DC,N,OV,Z
		CP <i>Wb</i> , #lit5	Compare <i>Wb</i> with lit5	1	1	C,DC,N,OV,Z
		CP <i>Wb</i> , <i>Ws</i>	Compare <i>Wb</i> with <i>Ws</i> (<i>Wb</i> – <i>Ws</i>)	1	1	C,DC,N,OV,Z
19	CP0	CP0 <i>f</i>	Compare <i>f</i> with 0x0000	1	1	C,DC,N,OV,Z
		CP0 <i>Ws</i>	Compare <i>Ws</i> with 0x0000	1	1	C,DC,N,OV,Z
20	CPB	CPB <i>f</i>	Compare <i>f</i> with WREG, with Borrow	1	1	C,DC,N,OV,Z
		CPB <i>Wb</i> , #lit5	Compare <i>Wb</i> with lit5, with Borrow	1	1	C,DC,N,OV,Z
		CPB <i>Wb</i> , <i>Ws</i>	Compare <i>Wb</i> with <i>Ws</i> , with Borrow (<i>Wb</i> – <i>Ws</i> – C)	1	1	C,DC,N,OV,Z
21	CPSEQ	CPSEQ <i>Wb</i> , <i>Wn</i>	Compare <i>Wb</i> with <i>Wn</i> , skip if =	1	1 (2 or 3)	None
22	CPSGT	CPSGT <i>Wb</i> , <i>Wn</i>	Compare <i>Wb</i> with <i>Wn</i> , skip if >	1	1 (2 or 3)	None
23	CPSLT	CPSLT <i>Wb</i> , <i>Wn</i>	Compare <i>Wb</i> with <i>Wn</i> , skip if <	1	1 (2 or 3)	None
24	CPSNE	CPSNE <i>Wb</i> , <i>Wn</i>	Compare <i>Wb</i> with <i>Wn</i> , skip if ≠	1	1 (2 or 3)	None
25	DAW	DAW <i>Wn</i>	<i>Wn</i> = decimal adjust <i>Wn</i>	1	1	C
26	DEC	DEC <i>f</i>	<i>f</i> = <i>f</i> – 1	1	1	C,DC,N,OV,Z
		DEC <i>f</i> , WREG	WREG = <i>f</i> – 1	1	1	C,DC,N,OV,Z
		DEC <i>Ws</i> , <i>Wd</i>	<i>Wd</i> = <i>Ws</i> – 1	1	1	C,DC,N,OV,Z
27	DEC2	DEC2 <i>f</i>	<i>f</i> = <i>f</i> – 2	1	1	C,DC,N,OV,Z
		DEC2 <i>f</i> , WREG	WREG = <i>f</i> – 2	1	1	C,DC,N,OV,Z
		DEC2 <i>Ws</i> , <i>Wd</i>	<i>Wd</i> = <i>Ws</i> – 2	1	1	C,DC,N,OV,Z
28	DISI	DISI #lit14	Disable Interrupts for <i>k</i> instruction cycles	1	1	None
29	DIV	DIV.S <i>Wm</i> , <i>Wn</i>	Signed 16/16-bit Integer Divide	1	18	N,Z,C, OV
		DIV.SD <i>Wm</i> , <i>Wn</i>	Signed 32/16-bit Integer Divide	1	18	N,Z,C, OV
		DIV.U <i>Wm</i> , <i>Wn</i>	Unsigned 16/16-bit Integer Divide	1	18	N,Z,C, OV
		DIV.UD <i>Wm</i> , <i>Wn</i>	Unsigned 32/16-bit Integer Divide	1	18	N,Z,C, OV
30	DIVF	DIVF <i>Wm</i> , <i>Wn</i>	Signed 16/16-bit Fractional Divide	1	18	N,Z,C, OV
31	DO	DO #lit14, Expr	Do code to PC + Expr, lit14 + 1 times	2	2	None
		DO <i>Wn</i> , Expr	Do code to PC + Expr, (<i>Wn</i>) + 1 times	2	2	None
32	ED	ED <i>Wm</i> * <i>Wm</i> , <i>Acc</i> , <i>Wx</i> , <i>Wy</i> , <i>Wxd</i>	Euclidean Distance (no accumulate)	1	1	OA,OB,OAB,SA,SB,SAB
33	EDAC	EDAC <i>Wm</i> * <i>Wm</i> , <i>Acc</i> , <i>Wx</i> , <i>Wy</i> , <i>Wxd</i>	Euclidean Distance	1	1	OA,OB,OAB,SA,SB,SAB
34	EXCH	EXCH <i>Wns</i> , <i>Wnd</i>	Swap <i>Wns</i> with <i>Wnd</i>	1	1	None

dsPIC30F5015/5016

TABLE 22-2: INSTRUCTION SET OVERVIEW (CONTINUED)

Base Instr #	Assembly Mnemonic	Assembly Syntax	Description	# of words	# of cycles	Status Flags Affected
35	FBCL	FBCL <i>Ws, Wnd</i>	Find Bit Change from Left (MSb) Side	1	1	C
36	FF1L	FF1L <i>Ws, Wnd</i>	Find First One from Left (MSb) Side	1	1	C
37	FF1R	FF1R <i>Ws, Wnd</i>	Find First One from Right (LSb) Side	1	1	C
38	GOTO	GOTO <i>Expr</i>	Go to address	2	2	None
		GOTO <i>Wn</i>	Go to indirect	1	2	None
39	INC	INC <i>f</i>	$f = f + 1$	1	1	C,DC,N,OV,Z
		INC <i>f, WREG</i>	$WREG = f + 1$	1	1	C,DC,N,OV,Z
		INC <i>Ws, Wd</i>	$Wd = Ws + 1$	1	1	C,DC,N,OV,Z
40	INC2	INC2 <i>f</i>	$f = f + 2$	1	1	C,DC,N,OV,Z
		INC2 <i>f, WREG</i>	$WREG = f + 2$	1	1	C,DC,N,OV,Z
		INC2 <i>Ws, Wd</i>	$Wd = Ws + 2$	1	1	C,DC,N,OV,Z
41	IOR	IOR <i>f</i>	$f = f .IOR. WREG$	1	1	N,Z
		IOR <i>f, WREG</i>	$WREG = f .IOR. WREG$	1	1	N,Z
		IOR <i>#lit10, Wn</i>	$Wd = lit10 .IOR. Wd$	1	1	N,Z
		IOR <i>Wb, Ws, Wd</i>	$Wd = Wb .IOR. Ws$	1	1	N,Z
		IOR <i>Wb, #lit5, Wd</i>	$Wd = Wb .IOR. lit5$	1	1	N,Z
42	LAC	LAC <i>Wso, #Slit4, Acc</i>	Load Accumulator	1	1	OA,OB,OAB,SA,SB,SAB
43	LNK	LNK <i>#lit14</i>	Link frame pointer	1	1	None
44	LSR	LSR <i>f</i>	$f = \text{Logical Right Shift } f$	1	1	C,N,OV,Z
		LSR <i>f, WREG</i>	$WREG = \text{Logical Right Shift } f$	1	1	C,N,OV,Z
		LSR <i>Ws, Wd</i>	$Wd = \text{Logical Right Shift } Ws$	1	1	C,N,OV,Z
		LSR <i>Wb, Wns, Wnd</i>	$Wnd = \text{Logical Right Shift } Wb \text{ by } Wns$	1	1	N,Z
		LSR <i>Wb, #lit5, Wnd</i>	$Wnd = \text{Logical Right Shift } Wb \text{ by } lit5$	1	1	N,Z
45	MAC	MAC <i>Wm*Wn, Acc, Wx, Wxd, Wy, Wyd, AWB</i>	Multiply and Accumulate	1	1	OA,OB,OAB,SA,SB,SAB
		MAC <i>Wm*Wm, Acc, Wx, Wxd, Wy, Wyd</i>	Square and Accumulate	1	1	OA,OB,OAB,SA,SB,SAB
46	MOV	MOV <i>f, Wn</i>	Move <i>f</i> to <i>Wn</i>	1	1	None
		MOV <i>f</i>	Move <i>f</i> to <i>f</i>	1	1	N,Z
		MOV <i>f, WREG</i>	Move <i>f</i> to WREG	1	1	N,Z
		MOV <i>#lit16, Wn</i>	Move 16-bit literal to <i>Wn</i>	1	1	None
		MOV.b <i>#lit8, Wn</i>	Move 8-bit literal to <i>Wn</i>	1	1	None
		MOV <i>Wn, f</i>	Move <i>Wn</i> to <i>f</i>	1	1	None
		MOV <i>Wso, Wdo</i>	Move <i>Ws</i> to <i>Wd</i>	1	1	None
		MOV <i>WREG, f</i>	Move WREG to <i>f</i>	1	1	N,Z
		MOV.D <i>Wns, Wd</i>	Move Double from <i>W(ns):W(ns + 1)</i> to <i>Wd</i>	1	2	None
MOV.D <i>Ws, Wnd</i>	Move Double from <i>Ws</i> to <i>W(nd + 1):W(nd)</i>	1	2	None		
47	MOVSAC	MOVSAC <i>Acc, Wx, Wxd, Wy, Wyd, AWB</i>	Prefetch and store Accumulator	1	1	None
48	MPY	MPY <i>Wm*Wn, Acc, Wx, Wxd, Wy, Wyd</i>	Multiply <i>Wm</i> by <i>Wn</i> to Accumulator	1	1	OA,OB,OAB,SA,SB,SAB
		MPY <i>Wm*Wm, Acc, Wx, Wxd, Wy, Wyd</i>	Square <i>Wm</i> to Accumulator	1	1	OA,OB,OAB,SA,SB,SAB
49	MPY.N	MPY.N <i>Wm*Wn, Acc, Wx, Wxd, Wy, Wyd</i>	-(Multiply <i>Wm</i> by <i>Wn</i>) to Accumulator	1	1	None
50	MSC	MSC <i>Wm*Wm, Acc, Wx, Wxd, Wy, Wyd, AWB</i>	Multiply and Subtract from Accumulator	1	1	OA,OB,OAB,SA,SB,SAB
51	MUL	MUL.SS <i>Wb, Ws, Wnd</i>	$\{Wnd+1, Wnd\} = \text{signed}(Wb) * \text{signed}(Ws)$	1	1	None
		MUL.SU <i>Wb, Ws, Wnd</i>	$\{Wnd+1, Wnd\} = \text{signed}(Wb) * \text{unsigned}(Ws)$	1	1	None
		MUL.US <i>Wb, Ws, Wnd</i>	$\{Wnd+1, Wnd\} = \text{unsigned}(Wb) * \text{signed}(Ws)$	1	1	None
		MUL.UU <i>Wb, Ws, Wnd</i>	$\{Wnd+1, Wnd\} = \text{unsigned}(Wb) * \text{unsigned}(Ws)$	1	1	None
		MUL.SU <i>Wb, #lit5, Wnd</i>	$\{Wnd+1, Wnd\} = \text{signed}(Wb) * \text{unsigned}(lit5)$	1	1	None
		MUL.UU <i>Wb, #lit5, Wnd</i>	$\{Wnd+1, Wnd\} = \text{unsigned}(Wb) * \text{unsigned}(lit5)$	1	1	None
		MUL <i>f</i>	$W3:W2 = f * WREG$	1	1	None

TABLE 22-2: INSTRUCTION SET OVERVIEW (CONTINUED)

Base Instr #	Assembly Mnemonic	Assembly Syntax	Description	# of words	# of cycles	Status Flags Affected
52	NEG	NEG <i>Acc</i>	Negate Accumulator	1	1	OA,OB,OAB,SA,SB,SAB
		NEG <i>f</i>	$f = \bar{f} + 1$	1	1	C,DC,N,OV,Z
		NEG <i>f, WREG</i>	$WREG = \bar{f} + 1$	1	1	C,DC,N,OV,Z
		NEG <i>Ws, Wd</i>	$Wd = \bar{Ws} + 1$	1	1	C,DC,N,OV,Z
53	NOP	NOP	No Operation	1	1	None
		NOPR	No Operation	1	1	None
54	POP	POP <i>f</i>	Pop <i>f</i> from Top-of-Stack (TOS)	1	1	None
		POP <i>Wdo</i>	Pop from Top-of-Stack (TOS) to <i>Wdo</i>	1	1	None
		POP.D <i>Wnd</i>	Pop from Top-of-Stack (TOS) to <i>W(nd):W(nd+1)</i>	1	2	None
		POP.S	Pop Shadow Registers	1	1	All
55	PUSH	PUSH <i>f</i>	Push <i>f</i> to Top-of-Stack (TOS)	1	1	None
		PUSH <i>Wso</i>	Push <i>Wso</i> to Top-of-Stack (TOS)	1	1	None
		PUSH.D <i>Wns</i>	Push <i>W(ns):W(ns+1)</i> to Top-of-Stack (TOS)	1	2	None
		PUSH.S	Push Shadow Registers	1	1	None
56	PWRSVAV	PWRSVAV <i>#lit1</i>	Go into Sleep or Idle mode	1	1	WDTO,Sleep
57	RCALL	RCALL <i>Expr</i>	Relative Call	1	2	None
		RCALL <i>Wn</i>	Computed Call	1	2	None
589	REPEAT	REPEAT <i>#lit14</i>	Repeat Next Instruction <i>lit14 + 1</i> times	1	1	None
		REPEAT <i>Wn</i>	Repeat Next Instruction (<i>Wn</i>) + 1 times	1	1	None
59	RESET	RESET	Software device Reset	1	1	None
60	RETFIE	RETFIE	Return from interrupt	1	3 (2)	None
61	RETLW	RETLW <i>#lit10, Wn</i>	Return with literal in <i>Wn</i>	1	3 (2)	None
62	RETURN	RETURN	Return from Subroutine	1	3 (2)	None
63	RLC	RLC <i>f</i>	<i>f</i> = Rotate Left through Carry <i>f</i>	1	1	C,N,Z
		RLC <i>f, WREG</i>	WREG = Rotate Left through Carry <i>f</i>	1	1	C,N,Z
		RLC <i>Ws, Wd</i>	<i>Wd</i> = Rotate Left through Carry <i>Ws</i>	1	1	C,N,Z
64	RLNC	RLNC <i>f</i>	<i>f</i> = Rotate Left (No Carry) <i>f</i>	1	1	N,Z
		RLNC <i>f, WREG</i>	WREG = Rotate Left (No Carry) <i>f</i>	1	1	N,Z
		RLNC <i>Ws, Wd</i>	<i>Wd</i> = Rotate Left (No Carry) <i>Ws</i>	1	1	N,Z
65	RRC	RRC <i>f</i>	<i>f</i> = Rotate Right through Carry <i>f</i>	1	1	C,N,Z
		RRC <i>f, WREG</i>	WREG = Rotate Right through Carry <i>f</i>	1	1	C,N,Z
		RRC <i>Ws, Wd</i>	<i>Wd</i> = Rotate Right through Carry <i>Ws</i>	1	1	C,N,Z
66	RRNC	RRNC <i>f</i>	<i>f</i> = Rotate Right (No Carry) <i>f</i>	1	1	N,Z
		RRNC <i>f, WREG</i>	WREG = Rotate Right (No Carry) <i>f</i>	1	1	N,Z
		RRNC <i>Ws, Wd</i>	<i>Wd</i> = Rotate Right (No Carry) <i>Ws</i>	1	1	N,Z
67	SAC	SAC <i>Acc, #Slit4, Wdo</i>	Store Accumulator	1	1	None
		SAC.R <i>Acc, #Slit4, Wdo</i>	Store Rounded Accumulator	1	1	None
68	SE	SE <i>Ws, Wnd</i>	<i>Wnd</i> = sign-extended <i>Ws</i>	1	1	C,N,Z
69	SETM	SETM <i>f</i>	<i>f</i> = 0xFFFF	1	1	None
		SETM <i>WREG</i>	WREG = 0xFFFF	1	1	None
		SETM <i>Ws</i>	<i>Ws</i> = 0xFFFF	1	1	None
70	SFTAC	SFTAC <i>Acc, Wn</i>	Arithmetic Shift Accumulator by (<i>Wn</i>)	1	1	OA,OB,OAB,SA,SB,SAB
		SFTAC <i>Acc, #Slit6</i>	Arithmetic Shift Accumulator by <i>Slit6</i>	1	1	OA,OB,OAB,SA,SB,SAB
71	SL	SL <i>f</i>	<i>f</i> = Left Shift <i>f</i>	1	1	C,N,OV,Z
		SL <i>f, WREG</i>	WREG = Left Shift <i>f</i>	1	1	C,N,OV,Z
		SL <i>Ws, Wd</i>	<i>Wd</i> = Left Shift <i>Ws</i>	1	1	C,N,OV,Z
		SL <i>Wb, Wns, Wnd</i>	<i>Wnd</i> = Left Shift <i>Wb</i> by <i>Wns</i>	1	1	N,Z
		SL <i>Wb, #lit5, Wnd</i>	<i>Wnd</i> = Left Shift <i>Wb</i> by <i>lit5</i>	1	1	N,Z

dsPIC30F5015/5016

TABLE 22-2: INSTRUCTION SET OVERVIEW (CONTINUED)

Base Instr #	Assembly Mnemonic	Assembly Syntax	Description	# of words	# of cycles	Status Flags Affected
72	SUB	SUB <i>Acc</i>	Subtract Accumulators	1	1	OA,OB,OAB,SA,SB,SAB
		SUB <i>f</i>	$f = f - WREG$	1	1	C,DC,N,OV,Z
		SUB <i>f, WREG</i>	$WREG = f - WREG$	1	1	C,DC,N,OV,Z
		SUB <i>#lit10, Wn</i>	$Wn = Wn - lit10$	1	1	C,DC,N,OV,Z
		SUB <i>Wb, Ws, Wd</i>	$Wd = Wb - Ws$	1	1	C,DC,N,OV,Z
		SUB <i>Wb, #lit5, Wd</i>	$Wd = Wb - lit5$	1	1	C,DC,N,OV,Z
73	SUBB	SUBB <i>f</i>	$f = f - WREG - (\overline{C})$	1	1	C,DC,N,OV,Z
		SUBB <i>f, WREG</i>	$WREG = f - WREG - (\overline{C})$	1	1	C,DC,N,OV,Z
		SUBB <i>#lit10, Wn</i>	$Wn = Wn - lit10 - (\overline{C})$	1	1	C,DC,N,OV,Z
		SUBB <i>Wb, Ws, Wd</i>	$Wd = Wb - Ws - (\overline{C})$	1	1	C,DC,N,OV,Z
		SUBB <i>Wb, #lit5, Wd</i>	$Wd = Wb - lit5 - (\overline{C})$	1	1	C,DC,N,OV,Z
74	SUBR	SUBR <i>f</i>	$f = WREG - f$	1	1	C,DC,N,OV,Z
		SUBR <i>f, WREG</i>	$WREG = WREG - f$	1	1	C,DC,N,OV,Z
		SUBR <i>Wb, Ws, Wd</i>	$Wd = Ws - Wb$	1	1	C,DC,N,OV,Z
		SUBR <i>Wb, #lit5, Wd</i>	$Wd = lit5 - Wb$	1	1	C,DC,N,OV,Z
75	SUBBR	SUBBR <i>f</i>	$f = WREG - f - (\overline{C})$	1	1	C,DC,N,OV,Z
		SUBBR <i>f, WREG</i>	$WREG = WREG - f - (\overline{C})$	1	1	C,DC,N,OV,Z
		SUBBR <i>Wb, Ws, Wd</i>	$Wd = Ws - Wb - (\overline{C})$	1	1	C,DC,N,OV,Z
		SUBBR <i>Wb, #lit5, Wd</i>	$Wd = lit5 - Wb - (\overline{C})$	1	1	C,DC,N,OV,Z
76	SWAP	SWAP <i>.b Wn</i>	$Wn = \text{nibble swap } Wn$	1	1	None
		SWAP <i>Wn</i>	$Wn = \text{byte swap } Wn$	1	1	None
77	TBLRDH	TBLRDH <i>Ws, Wd</i>	Read Prog<23:16> to Wd<7:0>	1	2	None
78	TBLRDL	TBLRDL <i>Ws, Wd</i>	Read Prog<15:0> to Wd	1	2	None
79	TBLWTH	TBLWTH <i>Ws, Wd</i>	Write Ws<7:0> to Prog<23:16>	1	2	None
80	TBLWTL	TBLWTL <i>Ws, Wd</i>	Write Ws to Prog<15:0>	1	2	None
81	ULNK	ULNK	Unlink Frame Pointer	1	1	None
82	XOR	XOR <i>f</i>	$f = f .XOR. WREG$	1	1	N,Z
		XOR <i>f, WREG</i>	$WREG = f .XOR. WREG$	1	1	N,Z
		XOR <i>#lit10, Wn</i>	$Wd = lit10 .XOR. Wd$	1	1	N,Z
		XOR <i>Wb, Ws, Wd</i>	$Wd = Wb .XOR. Ws$	1	1	N,Z
		XOR <i>Wb, #lit5, Wd</i>	$Wd = Wb .XOR. lit5$	1	1	N,Z
83	ZE	ZE <i>Ws, Wnd</i>	$Wnd = \text{Zero-Extend } Ws$	1	1	C,Z,N

23.0 DEVELOPMENT SUPPORT

The PIC® microcontrollers and dsPIC® digital signal controllers are supported with a full range of software and hardware development tools:

- Integrated Development Environment
 - MPLAB® IDE Software
- Compilers/Assemblers/Linkers
 - MPLAB C Compiler for Various Device Families
 - HI-TECH C for Various Device Families
 - MPASM™ Assembler
 - MPLINK™ Object Linker/
MPLIB™ Object Librarian
 - MPLAB Assembler/Linker/Librarian for Various Device Families
- Simulators
 - MPLAB SIM Software Simulator
- Emulators
 - MPLAB REAL ICE™ In-Circuit Emulator
- In-Circuit Debuggers
 - MPLAB ICD 3
 - PICKit™ 3 Debug Express
- Device Programmers
 - PICKit™ 2 Programmer
 - MPLAB PM3 Device Programmer
- Low-Cost Demonstration/Development Boards, Evaluation Kits, and Starter Kits

23.1 MPLAB Integrated Development Environment Software

The MPLAB IDE software brings an ease of software development previously unseen in the 8/16/32-bit microcontroller market. The MPLAB IDE is a Windows® operating system-based application that contains:

- A single graphical interface to all debugging tools
 - Simulator
 - Programmer (sold separately)
 - In-Circuit Emulator (sold separately)
 - In-Circuit Debugger (sold separately)
- A full-featured editor with color-coded context
- A multiple project manager
- Customizable data windows with direct edit of contents
- High-level source code debugging
- Mouse over variable inspection
- Drag and drop variables from source to watch windows
- Extensive on-line help
- Integration of select third party tools, such as IAR C Compilers

The MPLAB IDE allows you to:

- Edit your source files (either C or assembly)
- One-touch compile or assemble, and download to emulator and simulator tools (automatically updates all project information)
- Debug using:
 - Source files (C or assembly)
 - Mixed C and assembly
 - Machine code

MPLAB IDE supports multiple debugging tools in a single development paradigm, from the cost-effective simulators, through low-cost in-circuit debuggers, to full-featured emulators. This eliminates the learning curve when upgrading to tools with increased flexibility and power.

23.2 MPLAB C Compilers for Various Device Families

The MPLAB C Compiler code development systems are complete ANSI C compilers for Microchip's PIC18, PIC24 and PIC32 families of microcontrollers and the dsPIC30 and dsPIC33 families of digital signal controllers. These compilers provide powerful integration capabilities, superior code optimization and ease of use.

For easy source level debugging, the compilers provide symbol information that is optimized to the MPLAB IDE debugger.

23.3 HI-TECH C for Various Device Families

The HI-TECH C Compiler code development systems are complete ANSI C compilers for Microchip's PIC family of microcontrollers and the dsPIC family of digital signal controllers. These compilers provide powerful integration capabilities, omniscient code generation and ease of use.

For easy source level debugging, the compilers provide symbol information that is optimized to the MPLAB IDE debugger.

The compilers include a macro assembler, linker, pre-processor, and one-step driver, and can run on multiple platforms.

23.4 MPASM Assembler

The MPASM Assembler is a full-featured, universal macro assembler for PIC10/12/16/18 MCUs.

The MPASM Assembler generates relocatable object files for the MPLINK Object Linker, Intel® standard HEX files, MAP files to detail memory usage and symbol reference, absolute LST files that contain source lines and generated machine code and COFF files for debugging.

The MPASM Assembler features include:

- Integration into MPLAB IDE projects
- User-defined macros to streamline assembly code
- Conditional assembly for multi-purpose source files
- Directives that allow complete control over the assembly process

23.5 MPLINK Object Linker/ MPLIB Object Librarian

The MPLINK Object Linker combines relocatable objects created by the MPASM Assembler and the MPLAB C18 C Compiler. It can link relocatable objects from precompiled libraries, using directives from a linker script.

The MPLIB Object Librarian manages the creation and modification of library files of precompiled code. When a routine from a library is called from a source file, only the modules that contain that routine will be linked in with the application. This allows large libraries to be used efficiently in many different applications.

The object linker/library features include:

- Efficient linking of single libraries instead of many smaller files
- Enhanced code maintainability by grouping related modules together
- Flexible creation of libraries with easy module listing, replacement, deletion and extraction

23.6 MPLAB Assembler, Linker and Librarian for Various Device Families

MPLAB Assembler produces relocatable machine code from symbolic assembly language for PIC24, PIC32 and dsPIC devices. MPLAB C Compiler uses the assembler to produce its object file. The assembler generates relocatable object files that can then be archived or linked with other relocatable object files and archives to create an executable file. Notable features of the assembler include:

- Support for the entire device instruction set
- Support for fixed-point and floating-point data
- Command line interface
- Rich directive set
- Flexible macro language
- MPLAB IDE compatibility

23.7 MPLAB SIM Software Simulator

The MPLAB SIM Software Simulator allows code development in a PC-hosted environment by simulating the PIC MCUs and dsPIC® DSCs on an instruction level. On any given instruction, the data areas can be examined or modified and stimuli can be applied from a comprehensive stimulus controller. Registers can be logged to files for further run-time analysis. The trace buffer and logic analyzer display extend the power of the simulator to record and track program execution, actions on I/O, most peripherals and internal registers.

The MPLAB SIM Software Simulator fully supports symbolic debugging using the MPLAB C Compilers, and the MPASM and MPLAB Assemblers. The software simulator offers the flexibility to develop and debug code outside of the hardware laboratory environment, making it an excellent, economical software development tool.

23.8 MPLAB REAL ICE In-Circuit Emulator System

MPLAB REAL ICE In-Circuit Emulator System is Microchip's next generation high-speed emulator for Microchip Flash DSC and MCU devices. It debugs and programs PIC® Flash MCUs and dsPIC® Flash DSCs with the easy-to-use, powerful graphical user interface of the MPLAB Integrated Development Environment (IDE), included with each kit.

The emulator is connected to the design engineer's PC using a high-speed USB 2.0 interface and is connected to the target with either a connector compatible with in-circuit debugger systems (RJ11) or with the new high-speed, noise tolerant, Low-Voltage Differential Signal (LVDS) interconnection (CAT5).

The emulator is field upgradable through future firmware downloads in MPLAB IDE. In upcoming releases of MPLAB IDE, new devices will be supported, and new features will be added. MPLAB REAL ICE offers significant advantages over competitive emulators including low-cost, full-speed emulation, run-time variable watches, trace analysis, complex breakpoints, a ruggedized probe interface and long (up to three meters) interconnection cables.

23.9 MPLAB ICD 3 In-Circuit Debugger System

MPLAB ICD 3 In-Circuit Debugger System is Microchip's most cost effective high-speed hardware debugger/programmer for Microchip Flash Digital Signal Controller (DSC) and microcontroller (MCU) devices. It debugs and programs PIC® Flash microcontrollers and dsPIC® DSCs with the powerful, yet easy-to-use graphical user interface of MPLAB Integrated Development Environment (IDE).

The MPLAB ICD 3 In-Circuit Debugger probe is connected to the design engineer's PC using a high-speed USB 2.0 interface and is connected to the target with a connector compatible with the MPLAB ICD 2 or MPLAB REAL ICE systems (RJ-11). MPLAB ICD 3 supports all MPLAB ICD 2 headers.

23.10 PICkit 3 In-Circuit Debugger/Programmer and PICkit 3 Debug Express

The MPLAB PICkit 3 allows debugging and programming of PIC® and dsPIC® Flash microcontrollers at a most affordable price point using the powerful graphical user interface of the MPLAB Integrated Development Environment (IDE). The MPLAB PICkit 3 is connected to the design engineer's PC using a full speed USB interface and can be connected to the target via a Microchip debug (RJ-11) connector (compatible with MPLAB ICD 3 and MPLAB REAL ICE). The connector uses two device I/O pins and the reset line to implement in-circuit debugging and In-Circuit Serial Programming™.

The PICkit 3 Debug Express include the PICkit 3, demo board and microcontroller, hookup cables and CDROM with user's guide, lessons, tutorial, compiler and MPLAB IDE software.

23.11 PICkit 2 Development Programmer/Debugger and PICkit 2 Debug Express

The PICkit™ 2 Development Programmer/Debugger is a low-cost development tool with an easy to use interface for programming and debugging Microchip's Flash families of microcontrollers. The full featured Windows® programming interface supports baseline (PIC10F, PIC12F5xx, PIC16F5xx), midrange (PIC12F6xx, PIC16F), PIC18F, PIC24, dsPIC30, dsPIC33, and PIC32 families of 8-bit, 16-bit, and 32-bit microcontrollers, and many Microchip Serial EEPROM products. With Microchip's powerful MPLAB Integrated Development Environment (IDE) the PICkit™ 2 enables in-circuit debugging on most PIC® microcontrollers. In-Circuit-Debugging runs, halts and single steps the program while the PIC microcontroller is embedded in the application. When halted at a breakpoint, the file registers can be examined and modified.

The PICkit 2 Debug Express include the PICkit 2, demo board and microcontroller, hookup cables and CDROM with user's guide, lessons, tutorial, compiler and MPLAB IDE software.

23.12 MPLAB PM3 Device Programmer

The MPLAB PM3 Device Programmer is a universal, CE compliant device programmer with programmable voltage verification at VDDMIN and VDDMAX for maximum reliability. It features a large LCD display (128 x 64) for menus and error messages and a modular, detachable socket assembly to support various package types. The ICSP™ cable assembly is included as a standard item. In Stand-Alone mode, the MPLAB PM3 Device Programmer can read, verify and program PIC devices without a PC connection. It can also set code protection in this mode. The MPLAB PM3 connects to the host PC via an RS-232 or USB cable. The MPLAB PM3 has high-speed communications and optimized algorithms for quick programming of large memory devices and incorporates an MMC card for file storage and data applications.

23.13 Demonstration/Development Boards, Evaluation Kits, and Starter Kits

A wide variety of demonstration, development and evaluation boards for various PIC MCUs and dsPIC DSCs allows quick application development on fully functional systems. Most boards include prototyping areas for adding custom circuitry and provide application firmware and source code for examination and modification.

The boards support a variety of features, including LEDs, temperature sensors, switches, speakers, RS-232 interfaces, LCD displays, potentiometers and additional EEPROM memory.

The demonstration and development boards can be used in teaching environments, for prototyping custom circuits and for learning about various microcontroller applications.

In addition to the PICDEM™ and dsPICDEM™ demonstration/development board series of circuits, Microchip has a line of evaluation kits and demonstration software for analog filter design, KEELOQ® security ICs, CAN, IrDA®, PowerSmart battery management, SEEVAL® evaluation system, Sigma-Delta ADC, flow rate sensing, plus many more.

Also available are starter kits that contain everything needed to experience the specified device. This usually includes a single application and debug capability, all on one board.

Check the Microchip web page (www.microchip.com) for the complete list of demonstration, development and evaluation kits.

24.0 ELECTRICAL CHARACTERISTICS

This section provides an overview of dsPIC30F electrical characteristics. Additional information will be provided in future revisions of this document as it becomes available.

For detailed information about the dsPIC30F architecture and core, refer to the “*dsPIC30F Family Reference Manual*” (DS70046).

Absolute maximum ratings for the dsPIC30F family are listed below. Exposure to these maximum rating conditions for extended periods may affect device reliability. Functional operation of the device at these or any other conditions above the parameters indicated in the operation listings of this specification is not implied.

Absolute Maximum Ratings^(†)

Ambient temperature under bias	-40°C to +125°C
Storage temperature	-65°C to +150°C
Voltage on any pin with respect to V _{SS} (except V _{DD} and $\overline{\text{MCLR}}$) ⁽¹⁾	-0.3V to (V _{DD} + 0.3V)
Voltage on V _{DD} with respect to V _{SS}	-0.3V to +5.5V
Voltage on $\overline{\text{MCLR}}$ with respect to V _{SS}	0V to +13.25V
Maximum current out of V _{SS} pin	300 mA
Maximum current into V _{DD} pin ⁽²⁾	250 mA
Input clamp current, I _{IK} (V _I < 0 or V _I > V _{DD})	±20 mA
Output clamp current, I _{OK} (V _O < 0 or V _O > V _{DD})	±20 mA
Maximum output current sunk by any I/O pin.....	25 mA
Maximum output current sourced by any I/O pin	25 mA
Maximum current sunk by all ports	200 mA
Maximum current sourced by all ports ⁽²⁾	200 mA

Note 1: Voltage spikes below V_{SS} at the $\overline{\text{MCLR}}$ /V_{PP} pin, inducing currents greater than 80 mA, may cause latch-up. Thus, a series resistor of 50-100Ω should be used when applying a “low” level to the $\overline{\text{MCLR}}$ /V_{PP} pin, rather than pulling this pin directly to V_{SS}.

2: Maximum allowable current is a function of device maximum power dissipation. See [Table 24-6](#).

†NOTICE: Stresses above those listed under “Absolute Maximum Ratings” may cause permanent damage to the device. This is a stress rating only and functional operation of the device at those or any other conditions above those indicated in the operation listings of this specification is not implied. Exposure to maximum rating conditions for extended periods may affect device reliability.

dsPIC30F5015/5016

24.1 DC Characteristics

TABLE 24-1: OPERATING MIPS VS. VOLTAGE FOR dsPIC30F5015

VDD Range (in Volts)	Temp Range (in °C)	Max MIPS	
		dsPIC30F5015-30I	dsPIC30F5015-20E
4.5-5.5	-40 to +85	30	—
4.5-5.5	-40 to +125	—	20
3.0-3.6	-40 to +85	20	—
3.0-3.6	-40 to +125	—	15
2.5-3.0	-40 to +85	10	—

TABLE 24-2: OPERATING MIPS VS. VOLTAGE FOR dsPIC30F5016

VDD Range (in Volts)	Temp Range (in °C)	Max MIPS	
		dsPIC30F5016-30I	dsPIC30F5016-20E
4.5-5.5	-40 to +85	30	—
4.5-5.5	-40 to +125	—	20
3.0-3.6	-40 to +85	20	—
3.0-3.6	-40 to +125	—	15
2.5-3.0	-40 to +85	10	—

TABLE 24-3: THERMAL OPERATING CONDITIONS FOR dsPIC30F5015/5016

Rating	Symbol	Min	Typ	Max	Unit
dsPIC30F5015-30I/dsPIC30F5016-30I					
Operating Junction Temperature Range	TJ	-40	—	+125	°C
Operating Ambient Temperature Range	TA	-40	—	+85	°C
dsPIC30F5015-20E/dsPIC30F5016-20E					
Operating Junction Temperature Range	TJ	-40	—	+150	°C
Operating Ambient Temperature Range	TA	-40	—	+125	°C
Power Dissipation: Internal chip power dissipation: $P_{INT} = V_{DD} \times (I_{DD} - \sum I_{OH})$ I/O Pin Power Dissipation: $P_{I/O} = \sum (\{V_{DD} - V_{OH}\} \times I_{OH}) + \sum (V_{OL} \times I_{OL})$	PD	PINT + PI/O			W
Maximum Allowed Power Dissipation	PDMAX	$(T_J - T_A) / \theta_{JA}$			W

TABLE 24-4: THERMAL PACKAGING CHARACTERISTICS

Characteristic	Symbol	Typ	Max	Unit	Notes
Package Thermal Resistance, 80-pin TQFP (12x12x1mm)	θ_{JA}	39	—	°C/W	1
Package Thermal Resistance, 64-pin TQFP (10x10x1mm)	θ_{JA}	39	—	°C/W	1

Note 1: Junction to ambient thermal resistance, Theta-ja (θ_{JA}) numbers are achieved by package simulations.

TABLE 24-5: DC TEMPERATURE AND VOLTAGE SPECIFICATIONS

DC CHARACTERISTICS			Standard Operating Conditions: 2.5V to 5.5V (unless otherwise stated) Operating temperature -40°C ≤TA ≤+85°C for Industrial -40°C ≤TA ≤+125°C for Extended				
Param No.	Symbol	Characteristic	Min	Typ ⁽¹⁾	Max	Units	Conditions
Operating Voltage⁽²⁾							
DC10	VDD	Supply Voltage	2.5	—	5.5	V	Industrial temperature
DC11	VDD	Supply Voltage	3.0	—	5.5	V	Extended temperature
DC12	VDR	RAM Data Retention Voltage⁽³⁾	1.75	—	—	V	—
DC16	VPOR	VDD Start Voltage to ensure internal Power-on Reset signal	—	VSS	—	V	—
DC17	SVDD	VDD Rise Rate to ensure internal Power-on Reset signal	0.05	—	—	V/ms	0-5V in 0.1 sec 0-3V in 60 ms

Note 1: Data in “Typ” column is at 5V, 25°C unless otherwise stated. Parameters are for design guidance only and are not tested.

2: These parameters are characterized but not tested in manufacturing.

3: This is the limit to which VDD can be lowered without losing RAM data.

dsPIC30F5015/5016

TABLE 24-6: DC CHARACTERISTICS: OPERATING CURRENT (IDD)

DC CHARACTERISTICS			Standard Operating Conditions: 2.5V to 5.5V (unless otherwise stated) Operating temperature -40°C ≤TA ≤+85°C for Industrial -40°C ≤TA ≤+125°C for Extended		
Parameter No.	Typical ⁽¹⁾	Max	Units	Conditions	
Operating Current (IDD)⁽²⁾					
DC31a	5.6	10	mA	25°C	0.128 MIPS LPRC (512 kHz)
DC31b	5.7	10	mA	85°C	
DC31c	5.5	10	mA	125°C	
DC31e	14	23	mA	25°C	
DC31f	15	23	mA	85°C	
DC31g	15	23	mA	125°C	
DC30a	10	21	mA	25°C	(1.8 MIPS) FRC (7.37 MHz)
DC30b	12	21	mA	85°C	
DC30c	14	21	mA	125°C	
DC30e	23	38	mA	25°C	
DC30f	24	38	mA	85°C	
DC30g	25	38	mA	125°C	
DC23a	30	50	mA	25°C	4 MIPS
DC23b	32	50	mA	85°C	
DC23c	35	50	mA	125°C	
DC23e	32	53	mA	25°C	
DC23f	34	53	mA	85°C	
DC23g	35	53	mA	125°C	
DC24a	35	60	mA	25°C	10 MIPS
DC24b	37	60	mA	85°C	
DC24c	40	60	mA	125°C	
DC24e	62	95	mA	25°C	
DC24f	63	95	mA	85°C	
DC24g	65	95	mA	125°C	
DC27a	63	95	mA	25°C	20 MIPS
DC27b	65	95	mA	85°C	
DC27d	108	145	mA	25°C	
DC27e	127	145	mA	85°C	
DC27f	130	145	mA	125°C	
DC29a	151	200	mA	25°C	
DC29b	170	200	mA	85°C	30 MIPS

Note 1: Data in "Typical" column is at 5V, 25°C unless otherwise stated. Parameters are for design guidance only and are not tested.

2: The supply current is mainly a function of the operating voltage and frequency. Other factors such as I/O pin loading and switching rate, oscillator type, internal code execution pattern and temperature also have an impact on the current consumption. The test conditions for all IDD measurements are as follows: OSC1 driven with external square wave from rail to rail. All I/O pins are configured as Inputs and pulled to VDD. MCLR = VDD, WDT, FSCM, LVD and BOR are disabled. CPU, SRAM, Program Memory and Data Memory are operational. No peripheral modules are operating.

TABLE 24-7: DC CHARACTERISTICS: IDLE CURRENT (I_{IDLE})

DC CHARACTERISTICS			Standard Operating Conditions: 2.5V to 5.5V (unless otherwise stated) Operating temperature -40°C ≤T _A ≤+85°C for Industrial -40°C ≤T _A ≤+125°C for Extended	
Parameter No.	Typical ⁽¹⁾	Max	Units	Conditions
Operating Current (I_{DD})⁽²⁾				
DC51a	5.2	9	mA	25°C
DC51b	5.3	9	mA	85°C
DC51c	5.4	9	mA	125°C
DC51e	13	22	mA	25°C
DC51f	14	22	mA	85°C
DC51g	15	22	mA	125°C
0.128 MIPS LPRC (512 kHz)				
DC50a	8.1	13	mA	25°C
DC50b	8.2	13	mA	85°C
DC50c	8.3	13	mA	125°C
DC50e	19	32	mA	25°C
DC50f	20	32	mA	85°C
DC50g	21	32	mA	125°C
1.8 MIPS FRC (7.37 MHz)				
DC43a	12	26	mA	25°C
DC43b	14	26	mA	85°C
DC43c	17	26	mA	125°C
DC43e	25	42	mA	25°C
DC43f	26	42	mA	85°C
DC43g	28	42	mA	125°C
4 MIPS				
DC44a	23	40	mA	25°C
DC44b	25	40	mA	85°C
DC44c	26	40	mA	125°C
DC44e	42	68	mA	25°C
DC44f	43	68	mA	85°C
DC44g	45	68	mA	125°C
10 MIPS				
DC47a	40	55	mA	25°C
DC47b	40	55	mA	85°C
DC47d	70	85	mA	25°C
DC47e	72	85	mA	85°C
DC47f	74	85	mA	125°C
20 MIPS				
DC49a	98	120	mA	25°C
DC49b	103	120	mA	85°C
30 MIPS				

Note 1: Data in "Typical" column is at 5V, 25°C unless otherwise stated. Parameters are for design guidance only and are not tested.

2: Base I_{IDLE} current is measured with Core off, Clock on and all modules turned off.

dsPIC30F5015/5016

TABLE 24-8: DC CHARACTERISTICS: POWER-DOWN CURRENT (IPD)

DC CHARACTERISTICS			Standard Operating Conditions: 2.5V to 5.5V (unless otherwise stated) Operating temperature -40°C ≤TA ≤+85°C for Industrial -40°C ≤TA ≤+125°C for Extended			
Parameter No.	Typical ⁽¹⁾	Max	Units	Conditions		
Power Down Current (IPD)⁽²⁾						
DC60a	0.2	—	μA	25°C	3.3V Base Power Down Current	
DC60b	0.7	40	μA	85°C		
DC60c	12	65	μA	125°C		
DC60e	0.4	—	μA	25°C		5V
DC60f	1.7	55	μA	85°C		
DC60g	16	90	μA	125°C		
DC61a	10	30	μA	25°C	3.3V Watchdog Timer Current: ΔI _{WDT} ⁽³⁾	
DC61b	12	30	μA	85°C		
DC61c	12	30	μA	125°C		
DC61e	20	40	μA	25°C	5V	
DC61f	22	40	μA	85°C		
DC61g	23	40	μA	125°C		
DC62a	4	10	μA	25°C		3.3V Timer 1 w/32 kHz Crystal: ΔI _{T132} ⁽³⁾
DC62b	5	10	μA	85°C		
DC62c	4	10	μA	125°C		
DC62e	4	15	μA	25°C	5V	
DC62f	6	15	μA	85°C		
DC62g	5	15	μA	125°C		
DC63a	33	65	μA	25°C		
DC63b	38	65	μA	85°C		
DC63c	39	65	μA	125°C		
DC63e	38	70	μA	25°C	5V	
DC63f	41	70	μA	85°C		
DC63g	42	70	μA	125°C		

- Note**
- 1: Data in "Typ" column is at 5V, 25°C unless otherwise stated. Parameters are for design guidance only and are not tested.
 - 2: These parameters are characterized but not tested in manufacturing.
 - 3: The Δ current is the additional current consumed when the module is enabled. This current should be added to the base IPD current.

TABLE 24-9: DC CHARACTERISTICS: I/O PIN INPUT SPECIFICATIONS

DC CHARACTERISTICS			Standard Operating Conditions: 2.5V to 5.5V (unless otherwise stated) Operating temperature -40°C ≤TA ≤+85°C for Industrial -40°C ≤TA ≤+125°C for Extended				
Param No.	Symbol	Characteristic	Min	Typ ⁽¹⁾	Max	Units	Conditions
DI10 DI15 DI16 DI17 DI18 DI19	VIL	Input Low Voltage⁽²⁾ I/O pins: with Schmitt Trigger buffer	VSS	—	0.2 VDD	V	SMBus disabled SMBus enabled
		$\overline{\text{MCLR}}$	VSS	—	0.2 VDD	V	
		OSC1 (in XT, HS and LP modes)	VSS	—	0.2 VDD	V	
		OSC1 (in RC mode) ⁽³⁾	VSS	—	0.3 VDD	V	
		SDA, SCL	VSS	—	0.3 VDD	V	
		SDA, SCL	VSS	—	0.8	V	
DI20 DI25 DI26 DI27 DI28 DI29	VIH	Input High Voltage⁽²⁾ I/O pins: with Schmitt Trigger buffer	0.8 VDD	—	VDD	V	SMBus disabled SMBus enabled
		$\overline{\text{MCLR}}$	0.8 VDD	—	VDD	V	
		OSC1 (in XT, HS and LP modes)	0.7 VDD	—	VDD	V	
		OSC1 (in RC mode) ⁽³⁾	0.9 VDD	—	VDD	V	
		SDA, SCL	0.7 VDD	—	VDD	V	
		SDA, SCL	2.1	—	VDD	V	
DI30	ICNPU	CNxx Pull-up Current⁽²⁾	50	250	400	μA	VDD = 5V, VPIN = VSS
DI50 DI51 DI55 DI56	IIL	Input Leakage Current⁽²⁾⁽⁴⁾⁽⁵⁾ I/O ports	—	0.01	±1	μA	VSS ≤VPIN ≤VDD, Pin at high-impedance
		Analog Input Pins	—	0.50	—	μA	
		$\overline{\text{MCLR}}$	—	0.05	±5	μA	
		OSC1	—	0.05	±5	μA	

- Note 1:** Data in “Typ” column is at 5V, 25°C unless otherwise stated. Parameters are for design guidance only and are not tested.
- 2:** These parameters are characterized but not tested in manufacturing.
- 3:** In RC oscillator configuration, the OSC1/CLKI pin is a Schmitt Trigger input. It is not recommended that the dsPIC30F device be driven with an external clock while in RC mode.
- 4:** The leakage current on the $\overline{\text{MCLR}}$ pin is strongly dependent on the applied voltage level. The specified levels represent normal operating conditions. Higher leakage current may be measured at different input voltages.
- 5:** Negative current is defined as current sourced by the pin.

dsPIC30F5015/5016

TABLE 24-10: DC CHARACTERISTICS: I/O PIN OUTPUT SPECIFICATIONS

DC CHARACTERISTICS			Standard Operating Conditions: 2.5V to 5.5V (unless otherwise stated) Operating temperature $-40^{\circ}\text{C} \leq T_A \leq +85^{\circ}\text{C}$ for Industrial $-40^{\circ}\text{C} \leq T_A \leq +125^{\circ}\text{C}$ for Extended				
Param No.	Symbol	Characteristic	Min	Typ ⁽¹⁾	Max	Units	Conditions
DO10	VOL	Output Low Voltage⁽²⁾ I/O ports	—	—	0.6	V	$I_{OL} = 8.5 \text{ mA}$, $V_{DD} = 5\text{V}$
DO16			—	—	0.15	V	$I_{OL} = 2.0 \text{ mA}$, $V_{DD} = 3\text{V}$
DO16		OSC2/CLKO (RC or EC Osc mode)	—	—	0.6	V	$I_{OL} = 1.6 \text{ mA}$, $V_{DD} = 5\text{V}$
DO16			—	—	0.72	V	$I_{OL} = 2.0 \text{ mA}$, $V_{DD} = 3\text{V}$
DO20	VOH	Output High Voltage⁽²⁾ I/O ports	$V_{DD} - 0.7$	—	—	V	$I_{OH} = -3.0 \text{ mA}$, $V_{DD} = 5\text{V}$
DO26			$V_{DD} - 0.2$	—	—	V	$I_{OH} = -2.0 \text{ mA}$, $V_{DD} = 3\text{V}$
DO26		OSC2/CLKO (RC or EC Osc mode)	$V_{DD} - 0.7$	—	—	V	$I_{OH} = -1.3 \text{ mA}$, $V_{DD} = 5\text{V}$
DO26			$V_{DD} - 0.1$	—	—	V	$I_{OH} = -2.0 \text{ mA}$, $V_{DD} = 3\text{V}$
DO50	Cosc2	Capacitive Loading Specs on Output Pins⁽²⁾ OSC2/SOSC2 pin	—	—	15	pF	In XTL, XT, HS and LP modes when external clock is used to drive OSC1.
DO56	Cio	All I/O pins and OSC2	—	—	50	pF	RC or EC Osc mode
DO58	CB	SCL, SDA	—	—	400	pF	In I ² C™ mode

Note 1: Data in "Typ" column is at 5V, 25°C unless otherwise stated. Parameters are for design guidance only and are not tested.

2: These parameters are characterized but not tested in manufacturing.

FIGURE 24-1: BROWN-OUT RESET CHARACTERISTICS

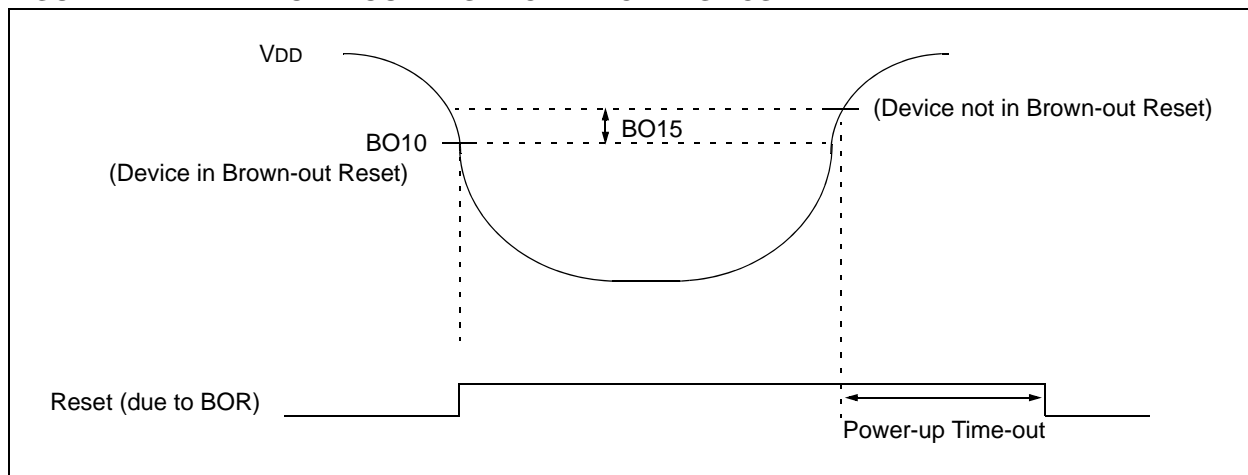

TABLE 24-11: ELECTRICAL CHARACTERISTICS: BOR

DC CHARACTERISTICS			Standard Operating Conditions: 2.5V to 5.5V (unless otherwise stated) Operating temperature -40°C ≤TA ≤+85°C for Industrial -40°C ≤TA ≤+125°C for Extended					
Param No.	Symbol	Characteristic	Min	Typ ⁽¹⁾	Max	Units	Conditions	
BO10	VBOR	BOR Voltage ⁽²⁾ on VDD transition low-to-high	BORV = 11 ⁽³⁾	—	—	—	V	Not in operating range
			BORV = 10	2.6	—	2.71	V	—
			BORV = 01	4.1	—	4.4	V	—
			BORV = 00	4.58	—	4.73	V	—
BO15	VBHYS	BOR hysteresis	—	5	—	mV	—	

- Note 1:** Data in “Typ” column is at 5V, 25°C unless otherwise stated. Parameters are for design guidance only and are not tested.
- 2:** These parameters are characterized but not tested in manufacturing.
- 3:** ‘11’ values not in usable operating range.

TABLE 24-12: DC CHARACTERISTICS: PROGRAM AND EEPROM

DC CHARACTERISTICS			Standard Operating Conditions: 2.5V to 5.5V (unless otherwise stated) Operating temperature -40°C ≤TA ≤+85°C for Industrial -40°C ≤TA ≤+125°C for Extended				
Param No.	Symbol	Characteristic	Min	Typ ⁽¹⁾	Max	Units	Conditions
Data EEPROM Memory⁽²⁾							
D120	ED	Byte Endurance	100K	1M	—	E/W	-40°C ≤TA ≤+85°C Using EECON to read/write VMIN = Minimum operating voltage
D121	VDRW	VDD for Read/Write	VMIN	—	5.5	V	
D122	TDEW	Erase/Write Cycle Time	0.8	2	2.6	ms	RTSP
D123	TRETD	Characteristic Retention	40	100	—	Year	Provided no other specifications are violated
D124	IDEW	IDD During Programming	—	10	30	mA	Row Erase
Program FLASH Memory⁽²⁾							
D130	EP	Cell Endurance	10K	100K	—	E/W	-40°C ≤TA ≤+85°C VMIN = Minimum operating voltage
D131	VPR	VDD for Read	VMIN	—	5.5	V	
D132	VEB	VDD for Bulk Erase	4.5	—	5.5	V	
D133	VPEW	VDD for Erase/Write	3.0	—	5.5	V	
D134	TPEW	Erase/Write Cycle Time	0.8	2	2.6	ms	RTSP
D135	TRETD	Characteristic Retention	40	100	—	Year	Provided no other specifications are violated
D137	IPEW	IDD During Programming	—	10	30	mA	Row Erase
D138	IEB	IDD During Programming	—	10	30	mA	Bulk Erase

- Note 1:** Data in “Typ” column is at 5V, 25°C unless otherwise stated.
- 2:** These parameters are characterized but not tested in manufacturing.

dsPIC30F5015/5016

24.2 AC Characteristics and Timing Parameters

The information contained in this section defines dsPIC30F AC characteristics and timing parameters.

TABLE 24-13: TEMPERATURE AND VOLTAGE SPECIFICATIONS – AC

AC CHARACTERISTICS	Standard Operating Conditions: 2.5V to 5.5V (unless otherwise stated)
	Operating temperature $-40^{\circ}\text{C} \leq T_A \leq +85^{\circ}\text{C}$ for Industrial $-40^{\circ}\text{C} \leq T_A \leq +125^{\circ}\text{C}$ for Extended
	Operating voltage V_{DD} range as described in Table 24-1 and Table 24-2 .

FIGURE 24-2: LOAD CONDITIONS FOR DEVICE TIMING SPECIFICATIONS

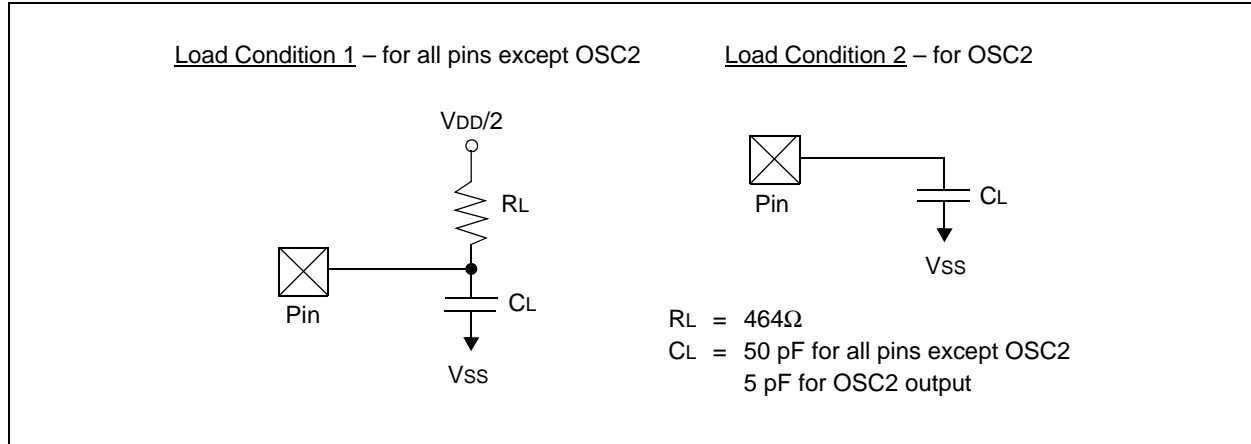

FIGURE 24-3: EXTERNAL CLOCK TIMING

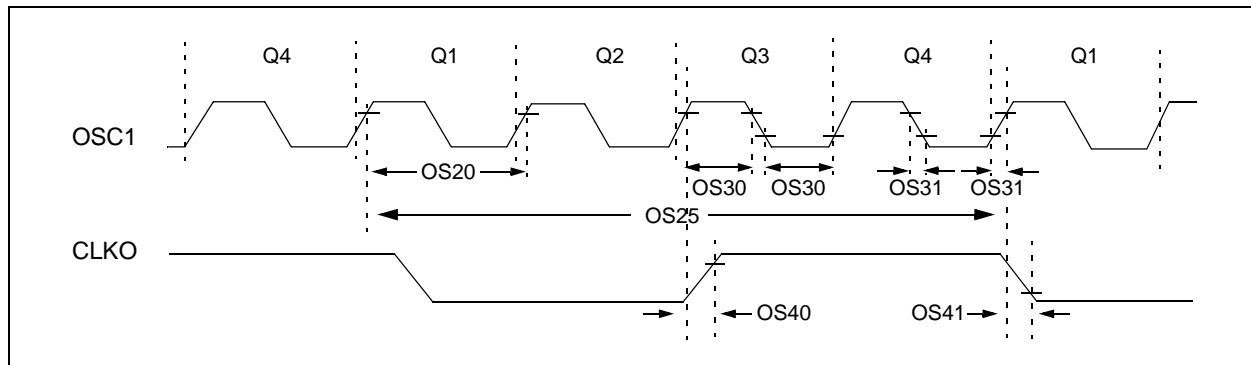

TABLE 24-14: EXTERNAL CLOCK TIMING REQUIREMENTS

AC CHARACTERISTICS			Standard Operating Conditions: 2.5V to 5.5V (unless otherwise stated) Operating temperature -40°C ≤TA ≤+85°C for Industrial -40°C ≤TA ≤+125°C for Extended				
Param No.	Symb ol	Characteristic	Min	Typ ⁽¹⁾	Max	Units	Conditions
OS10	Fosc	External CLKI Frequency ⁽²⁾ (External clocks allowed only in EC mode)	DC	—	40	MHz	EC
			4	—	10	MHz	EC with 4x PLL
			4	—	10	MHz	EC with 8x PLL
			4	—	7.5 ⁽³⁾	MHz	EC with 16x PLL
	Fosc	Oscillator Frequency ⁽²⁾	DC	—	4	MHz	RC
			0.4	—	4	MHz	XTL
			4	—	10	MHz	XT
			4	—	10	MHz	XT with 4x PLL
			4	—	10	MHz	XT with 8x PLL
			4	—	7.5 ⁽³⁾	MHz	XT with 16x PLL
			10	—	25	MHz	HS
			10	—	20 ⁽⁴⁾	MHz	HS/2 with 4x PLL
			10	—	20 ⁽⁴⁾	MHz	HS/2 with 8x PLL
			10	—	15 ⁽³⁾	MHz	HS/2 with 16x PLL
12 ⁽⁴⁾	—	25	MHz	HS/3 with 4x PLL			
12 ⁽⁴⁾	—	25	MHz	HS/3 with 8x PLL			
12 ⁽⁴⁾	—	22.5 ⁽³⁾	MHz	HS/3 with 16x PLL			
—	32.768	—	kHz	LP			
OS20	Tosc	Tosc = 1/Fosc	—	—	—	—	See parameter OS10 for Fosc value
OS25	Tcy	Instruction Cycle Time ⁽²⁾⁽⁵⁾	33	—	DC	ns	See Table 24-16
OS30	TosL, TosH	External Clock ⁽²⁾ in (OSC1) High or Low Time	.45 x Tosc	—	—	ns	EC
OS31	TosR, TosF	External Clock ⁽²⁾ in (OSC1) Rise or Fall Time	—	—	20	ns	EC
OS40	TckR	CLKO Rise Time ⁽²⁾⁽⁶⁾	—	—	—	ns	See parameter DO31
OS41	TckF	CLKO Fall Time ⁽²⁾⁽⁶⁾	—	—	—	ns	See parameter DO32

Note 1: Data in “Typ” column is at 5V, 25°C unless otherwise stated. Parameters are for design guidance only and are not tested.

2: These parameters are characterized but not tested in manufacturing.

3: Limited by the PLL output frequency range.

4: Limited by the PLL input frequency range.

5: Instruction cycle period (Tcy) equals four times the input oscillator time base period. All specified values are based on characterization data for that particular oscillator type under standard operating conditions with the device executing code. Exceeding these specified limits may result in an unstable oscillator operation and/or higher than expected current consumption. All devices are tested to operate at “Min.” values with an external clock applied to the OSC1/CLKI pin. When an external clock input is used, the “Max.” cycle time limit is “DC” (no clock) for all devices.

6: Measurements are taken in EC or ERC modes. The CLKO signal is measured on the OSC2 pin. CLKO is low for the Q1-Q2 period (1/2 Tcy) and high for the Q3-Q4 period (1/2 Tcy).

dsPIC30F5015/5016

TABLE 24-15: PLL CLOCK TIMING SPECIFICATIONS (V_{DD} = 2.5 TO 5.5 V)

AC CHARACTERISTICS		Standard Operating Conditions: 2.5V to 5.5V (unless otherwise stated) Operating temperature -40°C ≤T _A ≤+85°C for Industrial -40°C ≤T _A ≤+125°C for Extended					
Param No.	Symbol	Characteristic ⁽¹⁾	Min	Typ ⁽²⁾	Max	Units	Conditions
OS50	FPLLI	PLL Input Frequency Range ⁽²⁾	4	—	10	MHz	EC with 4x PLL
			4	—	10	MHz	EC with 8x PLL
			4	—	7.5 ⁽⁴⁾	MHz	EC with 16x PLL
			4	—	10	MHz	XT with 4x PLL
			4	—	10	MHz	XT with 8x PLL
			4	—	7.5 ⁽⁴⁾	MHz	XT with 16x PLL
			5 ⁽³⁾	—	10	MHz	HS/2 with 4x PLL
			5 ⁽³⁾	—	10	MHz	HS/2 with 8x PLL
			5 ⁽³⁾	—	7.5 ⁽⁴⁾	MHz	HS/2 with 16x PLL
			4	—	8.33 ⁽³⁾	MHz	HS/3 with 4x PLL
			4	—	8.33 ⁽³⁾	MHz	HS/3 with 8x PLL
			4	—	7.5 ⁽⁴⁾	MHz	HS/3 with 16x PLL
			OS51	FSYS	On-Chip PLL Output ⁽²⁾	16	—
OS52	TLOC	PLL Start-up Time (Lock Time)	—	20	50	μs	—

- Note 1:** These parameters are characterized but not tested in manufacturing.
Note 2: Data in “Typ” column is at 5V, 25°C unless otherwise stated. Parameters are for design guidance only and are not tested.
Note 3: Limited by oscillator frequency range.
Note 4: Limited by device operating frequency range.

TABLE 24-16: PLL JITTER

AC CHARACTERISTICS		Standard Operating Conditions: 2.5V to 5.5V (unless otherwise stated) Operating temperature -40°C ≤T _A ≤+85°C for Industrial -40°C ≤T _A ≤+125°C for Extended					
Param No.	Characteristic	Min	Typ ⁽¹⁾	Max	Units	Conditions	
OS61	x4 PLL	—	0.251	0.413	%	-40°C ≤T _A ≤+85°C	V _{DD} = 3.0 to 3.6V
		—	0.251	0.413	%	-40°C ≤T _A ≤+125°C	V _{DD} = 3.0 to 3.6V
		—	0.256	0.47	%	-40°C ≤T _A ≤+85°C	V _{DD} = 4.5 to 5.5V
		—	0.256	0.47	%	-40°C ≤T _A ≤+125°C	V _{DD} = 4.5 to 5.5V
	x8 PLL	—	0.355	0.584	%	-40°C ≤T _A ≤+85°C	V _{DD} = 3.0 to 3.6V
		—	0.355	0.584	%	-40°C ≤T _A ≤+125°C	V _{DD} = 3.0 to 3.6V
		—	0.362	0.664	%	-40°C ≤T _A ≤+85°C	V _{DD} = 4.5 to 5.5V
		—	0.362	0.664	%	-40°C ≤T _A ≤+125°C	V _{DD} = 4.5 to 5.5V
	x16 PLL	—	0.67	0.92	%	-40°C ≤T _A ≤+85°C	V _{DD} = 3.0 to 3.6V
		—	0.632	0.956	%	-40°C ≤T _A ≤+85°C	V _{DD} = 4.5 to 5.5V
		—	0.632	0.956	%	-40°C ≤T _A ≤+85°C	V _{DD} = 4.5 to 5.5V
		—	0.632	0.956	%	-40°C ≤T _A ≤+125°C	V _{DD} = 4.5 to 5.5V

- Note 1:** These parameters are characterized but not tested in manufacturing.

TABLE 24-17: INTERNAL CLOCK TIMING EXAMPLES

Clock Oscillator Mode	Fosc (MHz) ⁽¹⁾	Tcy (μsec) ⁽²⁾	MIPS ⁽³⁾ w/o PLL	MIPS ⁽³⁾ w PLL x4	MIPS ⁽³⁾ w PLL x8	MIPS ⁽³⁾ w PLL x16
EC	0.200	20.0	0.05	—	—	—
	4	1.0	1.0	4.0	8.0	16.0
	10	0.4	2.5	10.0	20.0	—
	25	0.16	6.25	—	—	—
XT	4	1.0	1.0	4.0	8.0	16.0
	10	0.4	2.5	10.0	20.0	—

Note 1: Assumption: Oscillator Postscaler is divide by 1.

2: Instruction Execution Cycle Time: $T_{CY} = 1/\text{MIPS}$.

3: Instruction Execution Frequency: $\text{MIPS} = (\text{Fosc} * \text{PLLx})/4$ (since there are 4 Q clocks per instruction cycle).

dsPIC30F5015/5016

TABLE 24-18: AC CHARACTERISTICS: INTERNAL FRC ACCURACY

AC CHARACTERISTICS		Standard Operating Conditions: 2.5V to 5.5V (unless otherwise stated) Operating temperature -40°C ≤TA ≤+85°C for Industrial -40°C ≤TA ≤+125°C for Extended					
Param No.	Characteristic	Min	Typ	Max	Units	Conditions	
Internal FRC Accuracy @ FRC Freq. = 7.37 MHz⁽¹⁾							
OS63	FRC	—	—	±2.00	%	-40°C ≤TA ≤+85°C	VDD = 3.0-5.5V
		—	—	±5.00	%	-40°C ≤TA ≤+125°C	VDD = 3.0-5.5V

Note 1: Frequency is calibrated to 7.37 MHz (±2%) at 25°C and 5V. TUN bits can be used to compensate for temperature drift.

TABLE 24-19: AC CHARACTERISTICS: INTERNAL LPRC ACCURACY

AC CHARACTERISTICS		Standard Operating Conditions: 2.5V to 5.5V (unless otherwise stated) Operating temperature -40°C ≤TA ≤+85°C for Industrial -40°C ≤TA ≤+125°C for Extended					
Param No.	Characteristic	Min	Typ	Max	Units	Conditions	
OS65A	LPRC @ Freq. = 512 kHz ⁽¹⁾	-50	—	+50	%	VDD = 5.0V, ±10%	
OS65B		-60	—	+60	%	VDD = 3.3V, ±10%	
OS65C		-70	—	+70	%	VDD = 2.5V	

Note 1: Change of LPRC frequency as VDD changes.

FIGURE 24-4: CLKO AND I/O TIMING CHARACTERISTICS

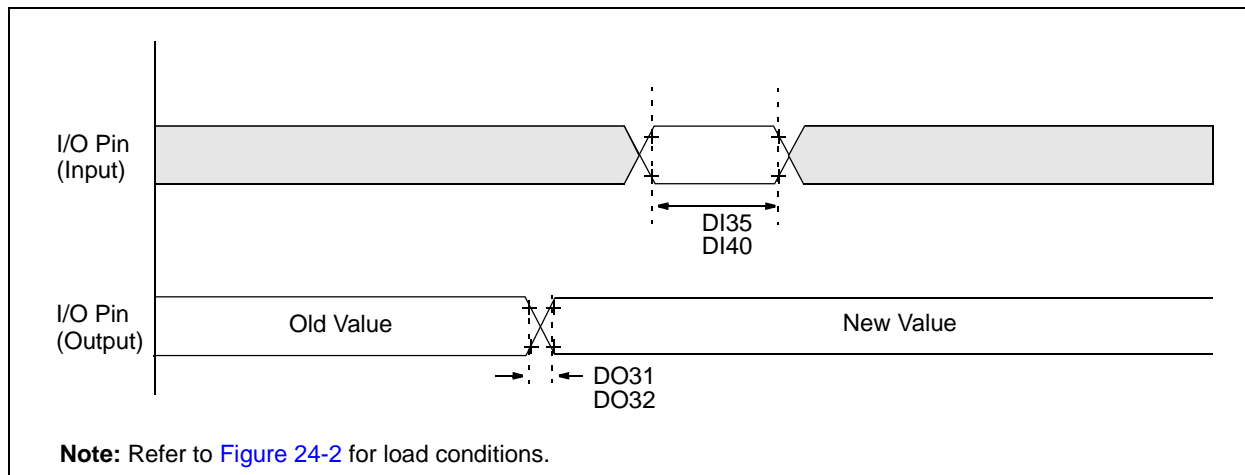

TABLE 24-20: CLKO AND I/O TIMING REQUIREMENTS

AC CHARACTERISTICS		Standard Operating Conditions: 2.5V to 5.5V (unless otherwise stated) Operating temperature $-40^{\circ}\text{C} \leq T_A \leq +85^{\circ}\text{C}$ for Industrial $-40^{\circ}\text{C} \leq T_A \leq +125^{\circ}\text{C}$ for Extended					
Param No.	Symbol	Characteristic ⁽¹⁾⁽²⁾⁽³⁾	Min	Typ ⁽⁴⁾	Max	Units	Conditions
DO31	TioR	Port output rise time	—	7	20	ns	—
DO32	TioF	Port output fall time	—	7	20	ns	—
DI35	TINP	INTx pin high or low time (output)	20	—	—	ns	—
DI40	TRBP	CNx high or low time (input)	2 TCY	—	—	ns	—

- Note 1:** These parameters are asynchronous events not related to any internal clock edges.
Note 2: Measurements are taken in RC mode and EC mode where CLKO output is $4 \times T_{osc}$.
Note 3: These parameters are characterized but not tested in manufacturing.
Note 4: Data in "Typ" column is at 5V, 25°C unless otherwise stated.

dsPIC30F5015/5016

FIGURE 24-5: RESET, WATCHDOG TIMER, OSCILLATOR START-UP TIMER AND POWER-UP TIMER TIMING CHARACTERISTICS

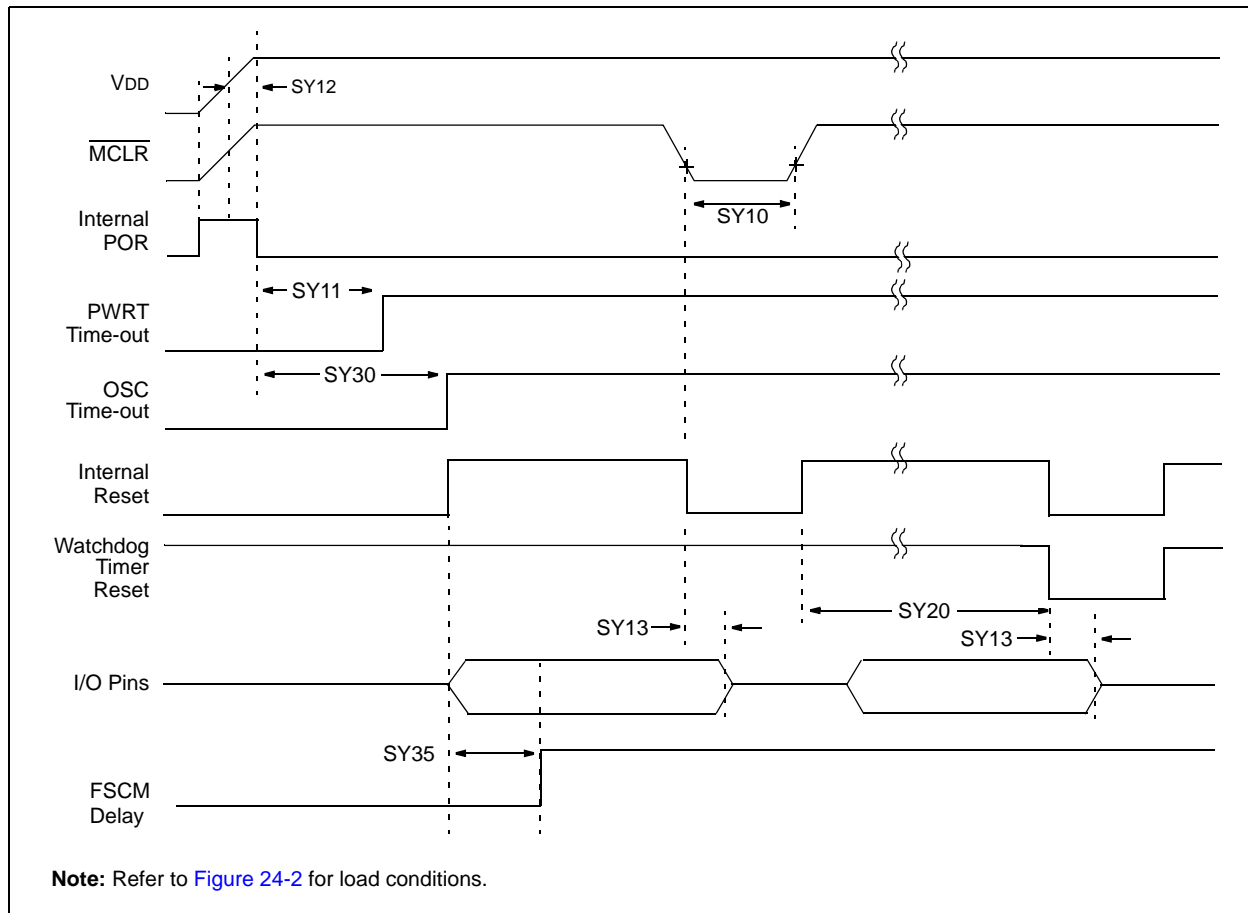

TABLE 24-21: RESET, WATCHDOG TIMER, OSCILLATOR START-UP TIMER, POWER-UP TIMER AND BROWN-OUT RESET TIMING REQUIREMENTS

AC CHARACTERISTICS			Standard Operating Conditions: 2.5V to 5.5V (unless otherwise stated) Operating temperature $-40^{\circ}\text{C} \leq T_A \leq +85^{\circ}\text{C}$ for Industrial $-40^{\circ}\text{C} \leq T_A \leq +125^{\circ}\text{C}$ for Extended				
Param No.	Symbol	Characteristic ⁽¹⁾	Min	Typ ⁽²⁾	Max	Units	Conditions
SY10	TmCL	MCLR Pulse Width (low)	2	—	—	μs	-40°C to $+85^{\circ}\text{C}$
SY11	TPWRT	Power-up Timer Period	2 8 32	4 16 64	6 24 96	ms	-40°C to $+85^{\circ}\text{C}$, $V_{DD} = 5\text{V}$ User programmable
SY12	TPOR	Power-on Reset Delay ⁽⁴⁾	3	10	30	μs	-40°C to $+85^{\circ}\text{C}$
SY13	TIOZ	I/O High-Impedance from MCLR Low or Watchdog Timer Reset	—	0.8	1.0	μs	—
SY20	TWDT1 TWDT2 TWDT3	Watchdog Timer Time-out Period (No Prescaler)	0.6 0.8 1.0	2.0 2.0 2.0	3.4 3.2 3.0	ms ms ms	$V_{DD} = 2.5\text{V}$ $V_{DD} = 3.3\text{V}, \pm 10\%$ $V_{DD} = 5\text{V}, \pm 10\%$
SY25	TBOR	Brown-out Reset Pulse Width ⁽³⁾	100	—	—	μs	$V_{DD} \leq V_{BOR}$ (D034)
SY30	TOST	Oscillator Start-up Timer Period	—	1024 TOSC	—	—	TOSC = OSC1 period
SY35	TFSCM	Fail-Safe Clock Monitor Delay	—	500	900	μs	-40°C to $+85^{\circ}\text{C}$

- Note 1:** These parameters are characterized but not tested in manufacturing.
Note 2: Data in “Typ” column is at 5V, 25°C unless otherwise stated.
Note 3: Refer to [Figure 24-1](#) and [Table 24-11](#) for BOR.
Note 4: Characterized by design but not tested.

FIGURE 24-6: BAND GAP START-UP TIME CHARACTERISTICS

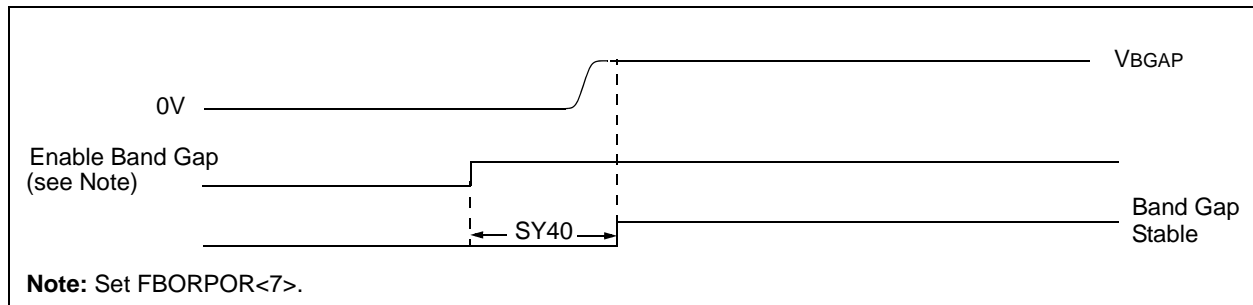

TABLE 24-22: BAND GAP START-UP TIME REQUIREMENTS

AC CHARACTERISTICS			Standard Operating Conditions: 2.5V to 5.5V (unless otherwise stated) Operating temperature $-40^{\circ}\text{C} \leq T_A \leq +85^{\circ}\text{C}$ for Industrial $-40^{\circ}\text{C} \leq T_A \leq +125^{\circ}\text{C}$ for Extended				
Param No.	Symbol	Characteristic ⁽¹⁾	Min	Typ	Max	Units	Conditions
SY40	TBGAP	Band Gap Start-up Time	—	40	65	μs	Defined as the time between the instant that the band gap is enabled and the moment that the band gap reference voltage is stable (RCON<13> Status bit).

- Note 1:** These parameters are characterized but not tested in manufacturing.

dsPIC30F5015/5016

FIGURE 24-7: TIMER1, 2, 3, 4 AND 5 EXTERNAL CLOCK TIMING CHARACTERISTICS

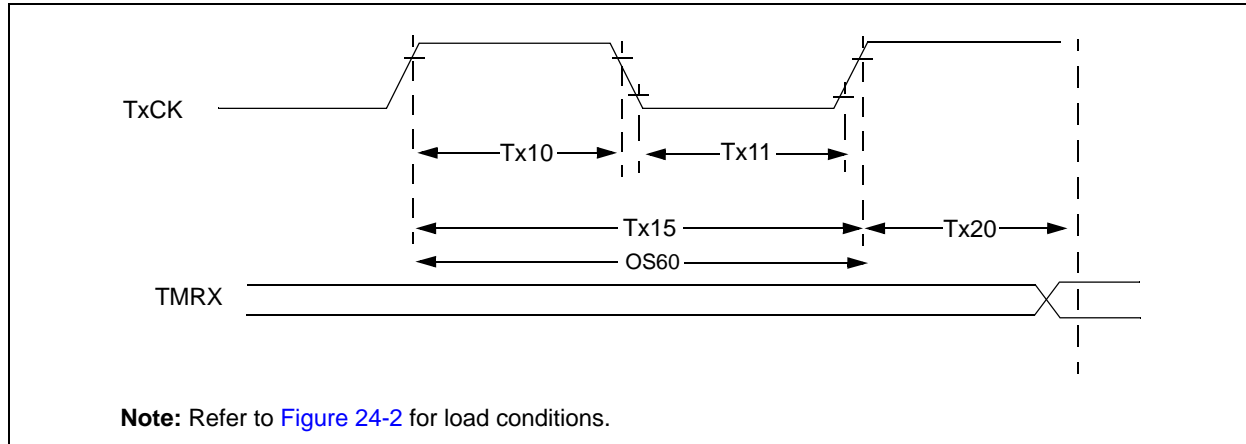

Note: Refer to [Figure 24-2](#) for load conditions.

TABLE 24-23: TIMER1 EXTERNAL CLOCK TIMING REQUIREMENTS⁽¹⁾

AC CHARACTERISTICS		Standard Operating Conditions: 2.5V to 5.5V (unless otherwise stated) Operating temperature $-40^{\circ}\text{C} \leq T_A \leq +85^{\circ}\text{C}$ for Industrial $-40^{\circ}\text{C} \leq T_A \leq +125^{\circ}\text{C}$ for Extended						
Param No.	Symbol	Characteristic		Min	Typ	Max	Units	Conditions
TA10	T _{TxH}	TxCK High Time	Synchronous, no prescaler	$0.5 T_{CY} + 20$	—	—	ns	Must also meet parameter TA15
			Synchronous, with prescaler	10	—	—	ns	
			Asynchronous	10	—	—	ns	
TA11	T _{TxL}	TxCK Low Time	Synchronous, no prescaler	$0.5 T_{CY} + 20$	—	—	ns	Must also meet parameter TA15
			Synchronous, with prescaler	10	—	—	ns	
			Asynchronous	10	—	—	ns	
TA15	T _{TxP}	TxCK Input Period	Synchronous, no prescaler	$T_{CY} + 10$	—	—	ns	—
			Synchronous, with prescaler	Greater of: 20 ns or $(T_{CY} + 40)/N$	—	—	—	N = prescale value (1, 8, 64, 256)
			Asynchronous	20	—	—	ns	—
OS60	F _{t1}	SOSC1/T1CK oscillator input frequency range (oscillator enabled by setting bit TCS (T1CON, bit 1))		DC	—	50	kHz	—
TA20	T _{CKEXTMRL}	Delay from External TxCK Clock Edge to Timer Increment		$0.5 T_{CY}$	—	$1.5 T_{CY}$	—	—

Note 1: Timer1 is a Type A.

TABLE 24-24: TIMER2 AND TIMER4 EXTERNAL CLOCK TIMING REQUIREMENTS

AC CHARACTERISTICS				Standard Operating Conditions: 2.5V to 5.5V (unless otherwise stated) Operating temperature -40°C ≤TA ≤+85°C for Industrial -40°C ≤TA ≤+125°C for Extended				
Param No.	Symbol	Characteristic		Min	Typ	Max	Units	Conditions
TB10	TtxH	TxCK High Time	Synchronous, no prescaler	0.5 Tcy + 20	—	—	ns	Must also meet parameter TB15
			Synchronous, with prescaler	10	—	—	ns	
TB11	TtxL	TxCK Low Time	Synchronous, no prescaler	0.5 Tcy + 20	—	—	ns	Must also meet parameter TB15
			Synchronous, with prescaler	10	—	—	ns	
TB15	TtxP	TxCK Input Period	Synchronous, no prescaler	Tcy + 10	—	—	ns	N = prescale value (1, 8, 64, 256)
			Synchronous, with prescaler	Greater of: 20 ns or (Tcy + 40)/N	—	—		
TB20	TCKEXTMRL	Delay from External TxCK Clock Edge to Timer Increment		0.5 Tcy	—	1.5 Tcy	—	—

TABLE 24-25: TIMER3 AND TIMER5 EXTERNAL CLOCK TIMING REQUIREMENTS

AC CHARACTERISTICS				Standard Operating Conditions: 2.5V to 5.5V (unless otherwise stated) Operating temperature -40°C ≤TA ≤+85°C for Industrial -40°C ≤TA ≤+125°C for Extended				
Param No.	Symbol	Characteristic		Min	Typ	Max	Units	Conditions
TC10	TtxH	TxCK High Time	Synchronous	0.5 Tcy + 20	—	—	ns	Must also meet parameter TC15
TC11	TtxL	TxCK Low Time	Synchronous	0.5 Tcy + 20	—	—	ns	Must also meet parameter TC15
TC15	TtxP	TxCK Input Period	Synchronous, no prescaler	Tcy + 10	—	—	ns	N = prescale value (1, 8, 64, 256)
			Synchronous, with prescaler	Greater of: 20 ns or (Tcy + 40)/N	—	—		
TC20	TCKEXTMRL	Delay from External TxCK Clock Edge to Timer Increment		0.5 Tcy	—	1.5 Tcy	—	—

dsPIC30F5015/5016

FIGURE 24-8: TIMERQ (QEI MODULE) EXTERNAL CLOCK TIMING CHARACTERISTICS

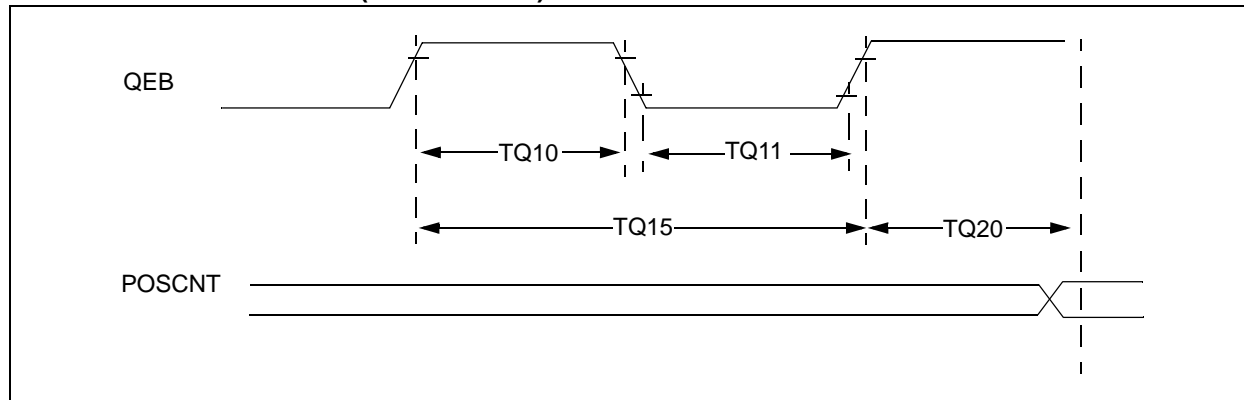

TABLE 24-26: QEI MODULE EXTERNAL CLOCK TIMING REQUIREMENTS

AC CHARACTERISTICS		Standard Operating Conditions: 2.5V to 5.5V (unless otherwise stated) Operating temperature $-40^{\circ}\text{C} \leq T_A \leq +85^{\circ}\text{C}$ for Industrial $-40^{\circ}\text{C} \leq T_A \leq +125^{\circ}\text{C}$ for Extended						
Param No.	Symbol	Characteristic ⁽¹⁾		Min	Typ	Max	Units	Conditions
TQ10	TtQH	TQCK High Time	Synchronous, with prescaler	$T_{CY} + 20$	—	—	ns	Must also meet parameter TQ15
TQ11	TtQL	TQCK Low Time	Synchronous, with prescaler	$T_{CY} + 20$	—	—	ns	Must also meet parameter TQ15
TQ15	TtQP	TQCP Input Period	Synchronous, with prescaler	$2 * T_{CY} + 40$	—	—	ns	—
TQ20	TCKEXTMRL	Delay from External TxCK Clock Edge to Timer Increment		$0.5 T_{CY}$	—	$1.5 T_{CY}$	ns	—

Note 1: These parameters are characterized but not tested in manufacturing.

FIGURE 24-9: INPUT CAPTURE (CAPx) TIMING CHARACTERISTICS

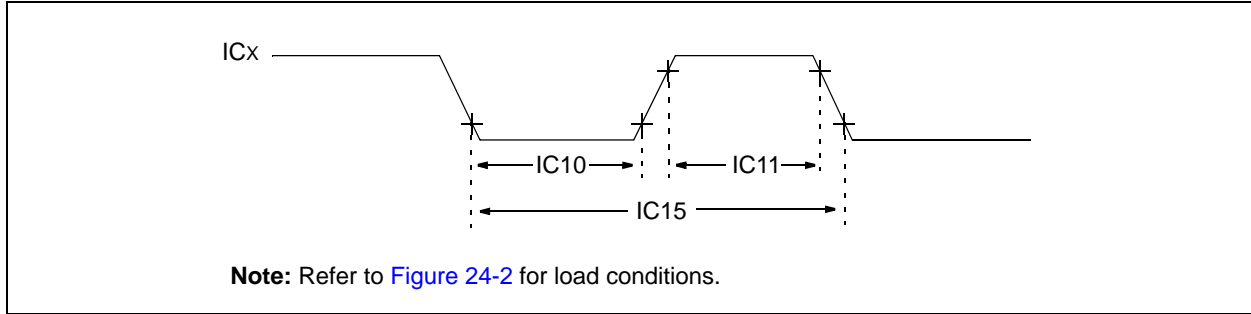

TABLE 24-27: INPUT CAPTURE TIMING REQUIREMENTS

AC CHARACTERISTICS		Standard Operating Conditions: 2.5V to 5.5V (unless otherwise stated) Operating temperature $-40^{\circ}\text{C} \leq T_A \leq +85^{\circ}\text{C}$ for Industrial $-40^{\circ}\text{C} \leq T_A \leq +125^{\circ}\text{C}$ for Extended					
Param No.	Symbol	Characteristic ⁽¹⁾		Min	Max	Units	Conditions
IC10	TccL	ICx Input Low Time	No Prescaler	$0.5 T_{CY} + 20$	—	ns	—
			With Prescaler	10	—	ns	
IC11	TccH	ICx Input High Time	No Prescaler	$0.5 T_{CY} + 20$	—	ns	—
			With Prescaler	10	—	ns	
IC15	TccP	ICx Input Period		$(2 T_{CY} + 40)/N$	—	ns	N = prescale value (1, 4, 16)

Note 1: These parameters are characterized but not tested in manufacturing.

FIGURE 24-10: OUTPUT COMPARE MODULE (OCx) TIMING CHARACTERISTICS

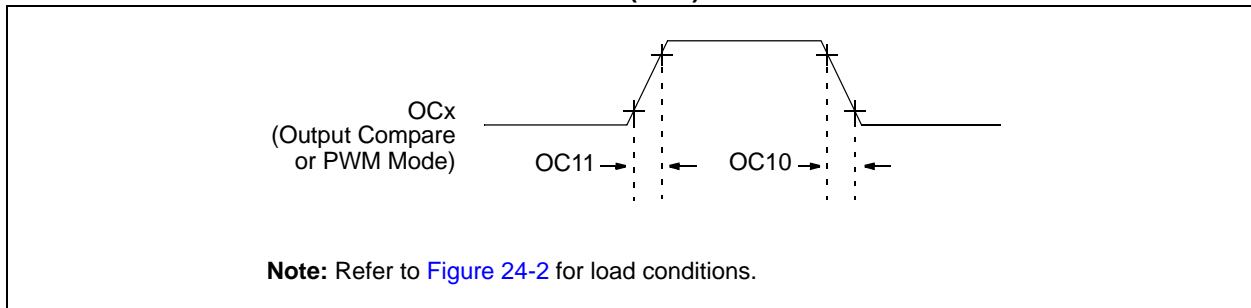

TABLE 24-28: OUTPUT COMPARE MODULE TIMING REQUIREMENTS

AC CHARACTERISTICS		Standard Operating Conditions: 2.5V to 5.5V (unless otherwise stated) Operating temperature $-40^{\circ}\text{C} \leq T_A \leq +85^{\circ}\text{C}$ for Industrial $-40^{\circ}\text{C} \leq T_A \leq +125^{\circ}\text{C}$ for Extended					
Param No.	Symbol	Characteristic ⁽¹⁾	Min	Typ ⁽²⁾	Max	Units	Conditions
OC10	TccF	OCx Output Fall Time	—	—	—	ns	See parameter DO32
OC11	TccR	OCx Output Rise Time	—	—	—	ns	See parameter DO31

Note 1: These parameters are characterized but not tested in manufacturing.

2: Data in "Typ" column is at 5V, 25°C unless otherwise stated. Parameters are for design guidance only and are not tested.

dsPIC30F5015/5016

FIGURE 24-11: OC/PWM MODULE TIMING CHARACTERISTICS

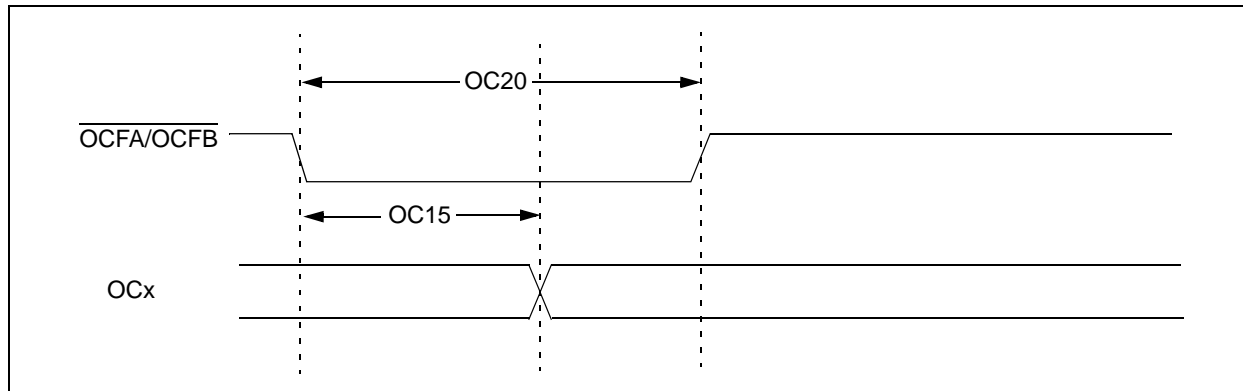

TABLE 24-29: SIMPLE OC/PWM MODE TIMING REQUIREMENTS

AC CHARACTERISTICS			Standard Operating Conditions: 2.5V to 5.5V (unless otherwise stated) Operating temperature -40°C ≤ TA ≤ +85°C for Industrial -40°C ≤ TA ≤ +125°C for Extended				
Param No.	Symbol	Characteristic ⁽¹⁾	Min	Typ ⁽²⁾	Max	Units	Conditions
OC15	TFD	Fault Input to PWM I/O Change	—	—	50	ns	—
OC20	TFLT	Fault Input Pulse Width	50	—	—	ns	—

Note 1: These parameters are characterized but not tested in manufacturing.

Note 2: Data in “Typ” column is at 5V, 25°C unless otherwise stated. Parameters are for design guidance only and are not tested.

FIGURE 24-12: MOTOR CONTROL PWM MODULE FAULT TIMING CHARACTERISTICS

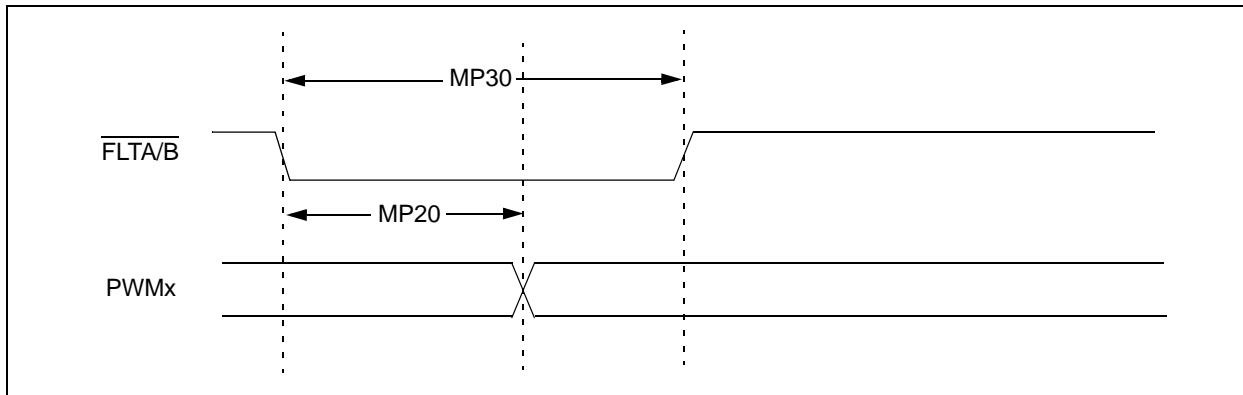

FIGURE 24-13: MOTOR CONTROL PWM MODULE TIMING CHARACTERISTICS

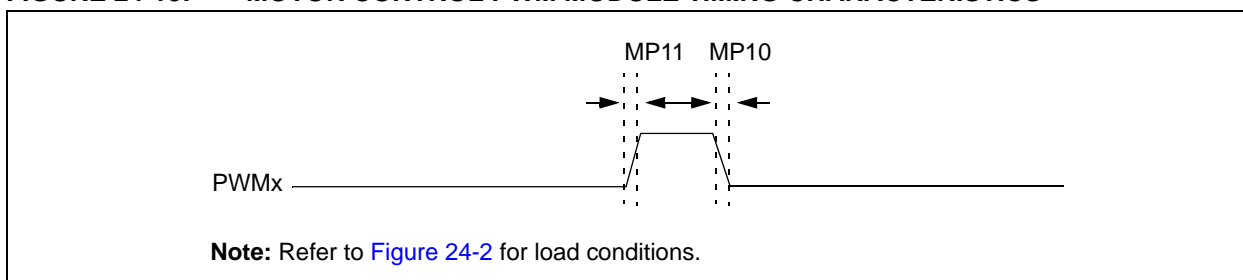

TABLE 24-30: MOTOR CONTROL PWM MODULE TIMING REQUIREMENTS

AC CHARACTERISTICS			Standard Operating Conditions: 2.5V to 5.5V (unless otherwise stated) Operating temperature $-40^{\circ}\text{C} \leq T_A \leq +85^{\circ}\text{C}$ for Industrial $-40^{\circ}\text{C} \leq T_A \leq +125^{\circ}\text{C}$ for Extended				
Param No.	Symbol	Characteristic ⁽¹⁾	Min	Typ ⁽²⁾	Max	Units	Conditions
MP10	T_{FPWM}	PWM Output Fall Time	—	—	—	ns	See parameter DO32
MP11	T_{RPWM}	PWM Output Rise Time	—	—	—	ns	See parameter DO31
MP20	T_{FD}	Fault Input \downarrow to PWM I/O Change	—	—	50	ns	—
MP30	T_{FH}	Minimum Pulse Width	50	—	—	ns	—

Note 1: These parameters are characterized but not tested in manufacturing.

Note 2: Data in “Typ” column is at 5V, 25°C unless otherwise stated. Parameters are for design guidance only and are not tested.

dsPIC30F5015/5016

FIGURE 24-14: QEA/QEB INPUT CHARACTERISTICS

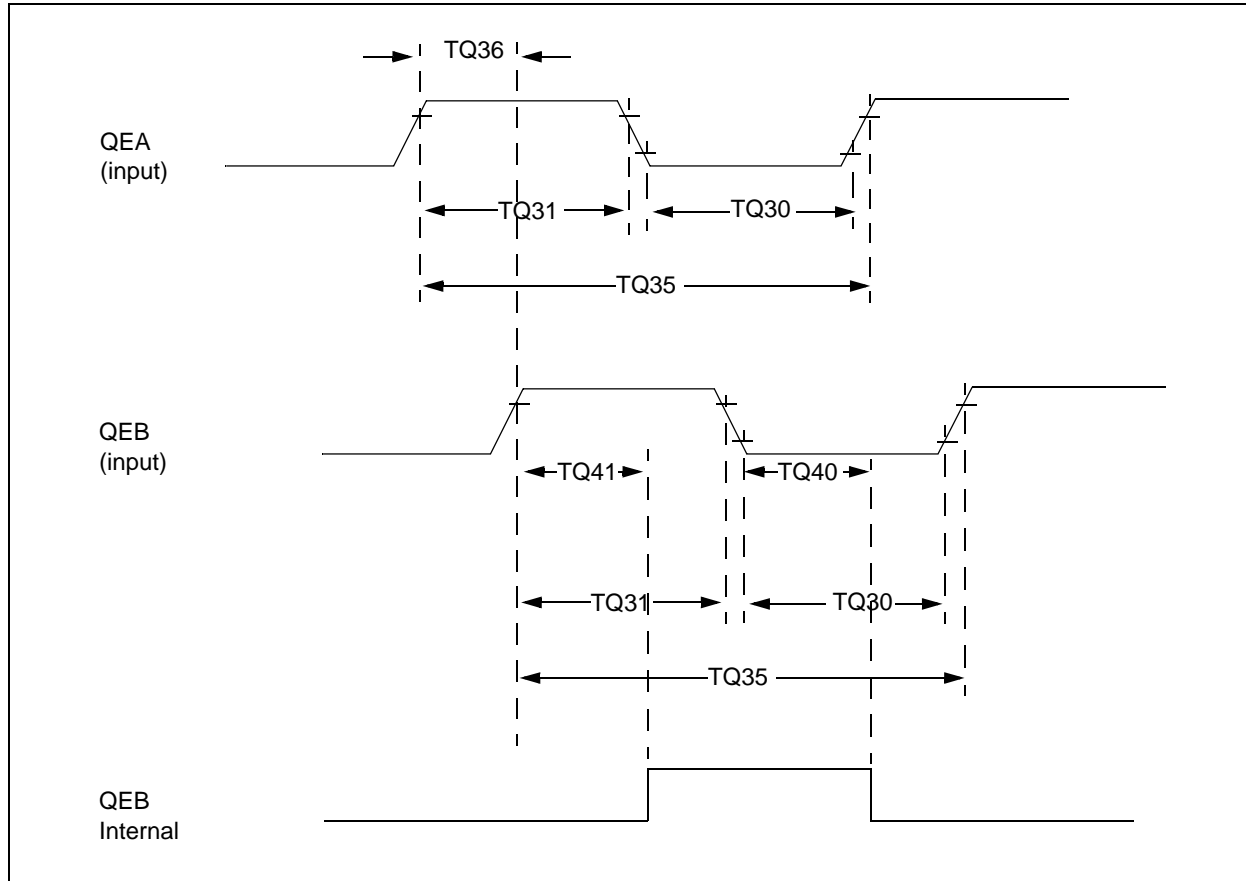

TABLE 24-31: QUADRATURE DECODER TIMING REQUIREMENTS

AC CHARACTERISTICS		Standard Operating Conditions: 2.5V to 5.5V (unless otherwise stated) Operating temperature $-40^{\circ}\text{C} \leq T_A \leq +85^{\circ}\text{C}$ for Industrial $-40^{\circ}\text{C} \leq T_A \leq +125^{\circ}\text{C}$ for Extended				
Param No.	Symbol	Characteristic ⁽¹⁾	Typ ⁽²⁾	Max	Units	Conditions
TQ30	TQuL	Quadrature Input Low Time	6 T _{CY}	—	ns	—
TQ31	TQuH	Quadrature Input High Time	6 T _{CY}	—	ns	—
TQ35	TQuIN	Quadrature Input Period	12 T _{CY}	—	ns	—
TQ36	TQuP	Quadrature Phase Period	3 T _{CY}	—	ns	—
TQ40	TQuFL	Filter Time to Recognize Low, with Digital Filter	3 * N * T _{CY}	—	ns	N = 1, 2, 4, 16, 32, 64, 128 and 256 (Note 2)
TQ41	TQuFH	Filter Time to Recognize High, with Digital Filter	3 * N * T _{CY}	—	ns	N = 1, 2, 4, 16, 32, 64, 128 and 256 (Note 2)

Note 1: These parameters are characterized but not tested in manufacturing.

Note 2: N = Index Channel Digital Filter Clock Divide Select Bits. Refer to **Section 16. “Quadrature Encoder Interface (QEI)”** (DS70046) in the “dsPIC30F Family Reference Manual”.

FIGURE 24-15: QEI MODULE INDEX PULSE TIMING CHARACTERISTICS

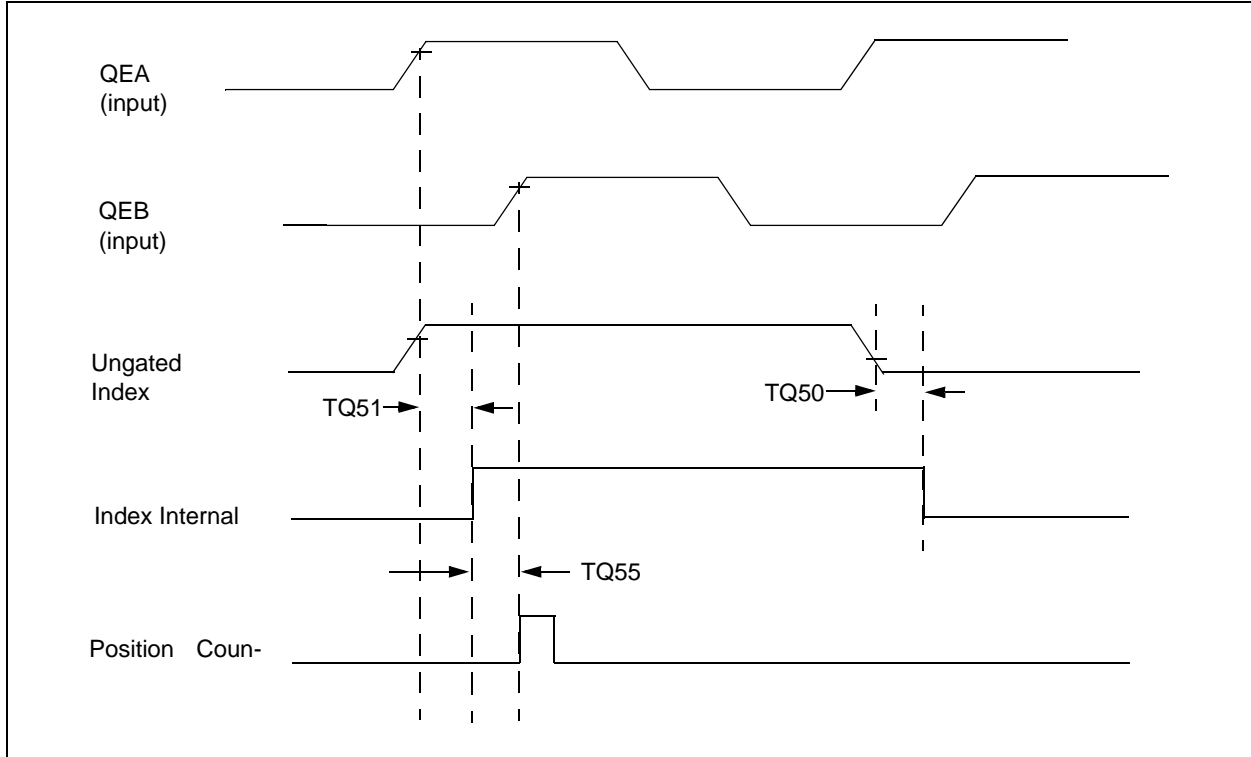

TABLE 24-32: QEI INDEX PULSE TIMING REQUIREMENTS

AC CHARACTERISTICS		Standard Operating Conditions: 2.5V to 5.5V (unless otherwise stated) Operating temperature -40°C ≤ TA ≤ +85°C for Industrial -40°C ≤ TA ≤ +125°C for Extended				
Param No.	Symbol	Characteristic ⁽¹⁾	Min	Max	Units	Conditions
TQ50	TqIL	Filter Time to Recognize Low, with Digital Filter	3 * N * TcY	—	ns	N = 1, 2, 4, 16, 32, 64, 128 and 256 (Note 2)
TQ51	TqiH	Filter Time to Recognize High, with Digital Filter	3 * N * TcY	—	ns	N = 1, 2, 4, 16, 32, 64, 128 and 256 (Note 2)
TQ55	Tqidxr	Index Pulse Recognized to Position Counter Reset (Ungated Index)	3 TcY	—	ns	—

Note 1: These parameters are characterized but not tested in manufacturing.

Note 2: Alignment of index pulses to QEA and QEB is shown for position counter reset timing only. Shown for forward direction only (QEA leads QEB). Same timing applies for reverse direction (QEA lags QEB) but index pulse recognition occurs on falling edge.

dsPIC30F5015/5016

FIGURE 24-16: SPI MODULE MASTER MODE (CKE = 0) TIMING CHARACTERISTICS

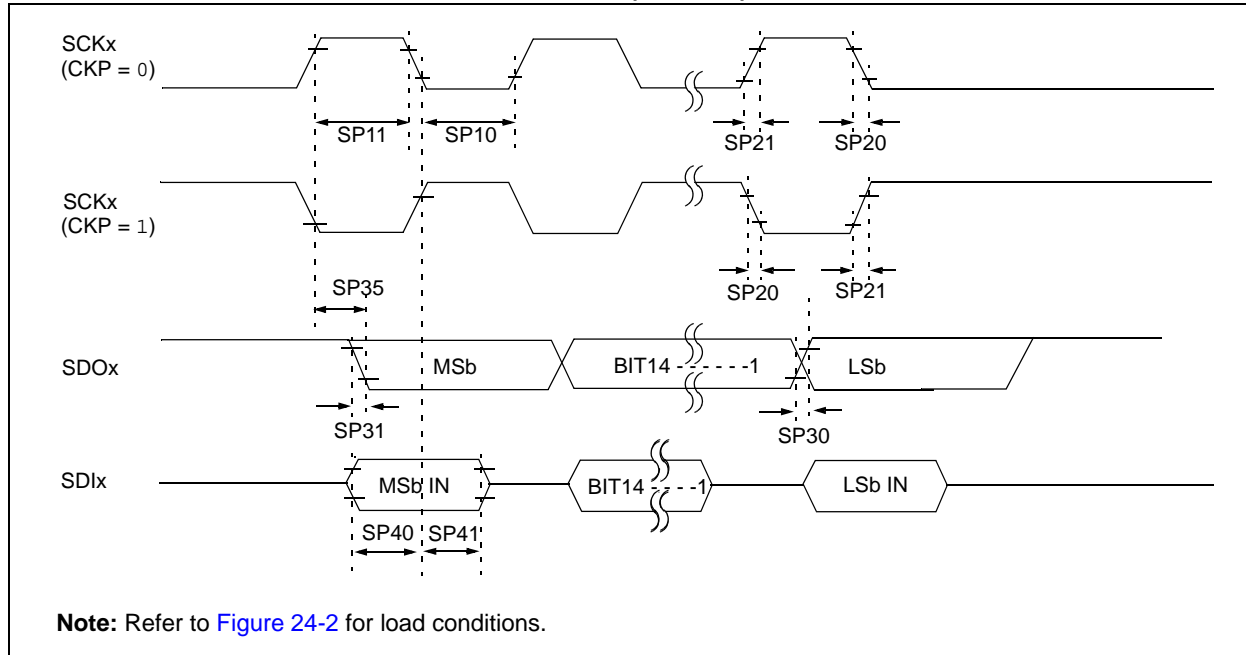

TABLE 24-33: SPI MASTER MODE (CKE = 0) TIMING REQUIREMENTS

AC CHARACTERISTICS			Standard Operating Conditions: 2.5V to 5.5V (unless otherwise stated) Operating temperature -40°C ≤TA ≤+85°C for Industrial -40°C ≤TA ≤+125°C for Extended				
Param No.	Symbol	Characteristic ⁽¹⁾	Min	Typ ⁽²⁾	Max	Units	Conditions
SP10	TscL	SCKx Output Low Time ⁽³⁾	Tcy/2	—	—	ns	—
SP11	TscH	SCKx Output High Time ⁽³⁾	Tcy/2	—	—	ns	—
SP20	TscF	SCKx Output Fall Time ⁽⁴⁾	—	—	—	ns	See parameter DO32
SP21	TscR	SCKx Output Rise Time ⁽⁴⁾	—	—	—	ns	See parameter DO31
SP30	TdoF	SDOx Data Output Fall Time ⁽⁴⁾	—	—	—	ns	See parameter DO32
SP31	TdoR	SDOx Data Output Rise Time ⁽⁴⁾	—	—	—	ns	See parameter DO31
SP35	Tsch2doV, TscL2doV	SDOx Data Output Valid after SCKx Edge	—	—	30	ns	—
SP40	TdiV2scH, TdiV2scL	Setup Time of SDIx Data Input to SCKx Edge	20	—	—	ns	—
SP41	Tsch2diL, TscL2diL	Hold Time of SDIx Data Input to SCKx Edge	20	—	—	ns	—

- Note 1:** These parameters are characterized but not tested in manufacturing.
- Note 2:** Data in “Typ” column is at 5V, 25°C unless otherwise stated. Parameters are for design guidance only and are not tested.
- Note 3:** The minimum clock period for SCK is 100 ns. Therefore, the clock generated in Master mode must not violate this specification.
- Note 4:** Assumes 50 pF load on all SPI pins.

FIGURE 24-17: SPI MODULE MASTER MODE (CKE = 1) TIMING CHARACTERISTICS

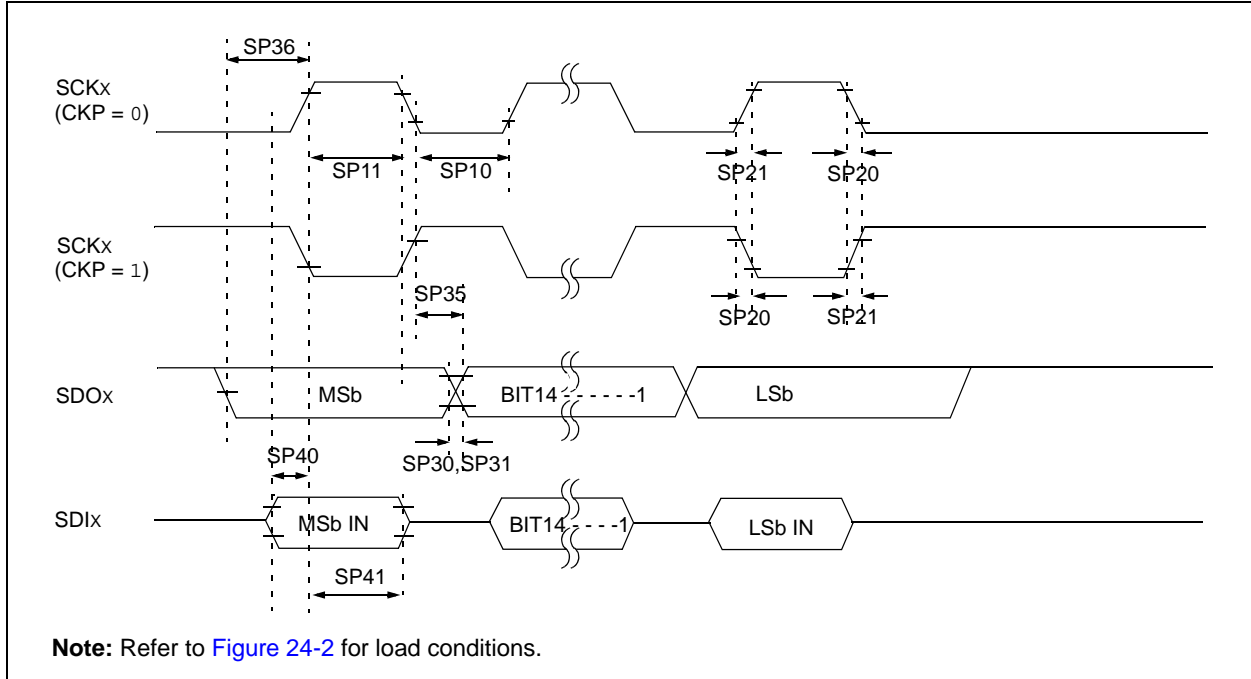

TABLE 24-34: SPI MODULE MASTER MODE (CKE = 1) TIMING REQUIREMENTS

AC CHARACTERISTICS			Standard Operating Conditions: 2.5V to 5.5V (unless otherwise stated) Operating temperature -40°C ≤ TA ≤ +85°C for Industrial -40°C ≤ TA ≤ +125°C for Extended				
Param No.	Symbol	Characteristic ⁽¹⁾	Min	Typ ⁽²⁾	Max	Units	Conditions
SP10	TscL	SCKx output low time ⁽³⁾	Tcy/2	—	—	ns	—
SP11	Tsch	SCKx output high time ⁽³⁾	Tcy/2	—	—	ns	—
SP20	TscF	SCKx output fall time ⁽⁴⁾	—	—	—	ns	See parameter DO32
SP21	TscR	SCKx output rise time ⁽⁴⁾	—	—	—	ns	See parameter DO31
SP30	TdoF	SDOx data output fall time ⁽⁴⁾	—	—	—	ns	See parameter DO32
SP31	TdoR	SDOx data output rise time ⁽⁴⁾	—	—	—	ns	See parameter DO31
SP35	Tsch2doV, TscL2doV	SDOx data output valid after SCKx edge	—	—	—	ns	—
SP36	TdoV2sc, TdoV2scL	SDOx data output setup to first SCKx edge	30	—	—	ns	—
SP40	TdiV2scH, TdiV2scL	Setup time of SDIx data input to SCKx edge	20	—	—	ns	—
SP41	Tsch2diL, TscL2diL	Hold time of SDIx data input to SCKx edge	20	—	—	ns	—

Note 1: These parameters are characterized but not tested in manufacturing.

2: Data in “Typ” column is at 5V, 25°C unless otherwise stated. Parameters are for design guidance only and are not tested.

3: The minimum clock period for SCK is 100 ns. Therefore, the clock generated in Master mode must not violate this specification.

4: Assumes 50 pF load on all SPI pins.

dsPIC30F5015/5016

FIGURE 24-18: SPI MODULE SLAVE MODE (CKE = 0) TIMING CHARACTERISTICS

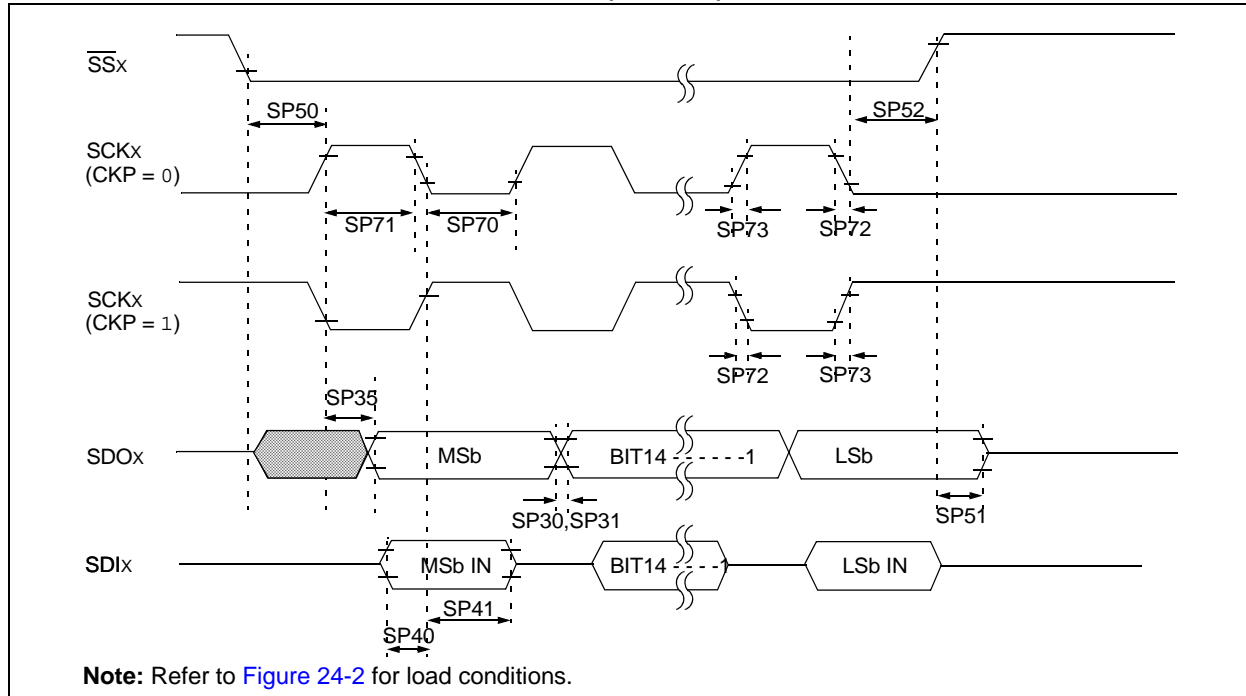

TABLE 24-35: SPI MODULE SLAVE MODE (CKE = 0) TIMING REQUIREMENTS

AC CHARACTERISTICS			Standard Operating Conditions: 2.5V to 5.5V (unless otherwise stated) Operating temperature -40°C ≤ TA ≤ +85°C for Industrial -40°C ≤ TA ≤ +125°C for Extended				
Param No.	Symbol	Characteristic ⁽¹⁾	Min	Typ ⁽²⁾	Max	Units	Conditions
SP70	TscL	SCKx Input Low Time	30	—	—	ns	—
SP71	TscH	SCKx Input High Time	30	—	—	ns	—
SP72	TscF	SCKx Input Fall Time ⁽³⁾	—	10	25	ns	—
SP73	TscR	SCKx Input Rise Time ⁽³⁾	—	10	25	ns	—
SP30	TdoF	SDOx Data Output Fall Time ⁽³⁾	—	—	—	ns	See parameter DO32
SP31	TdoR	SDOx Data Output Rise Time ⁽³⁾	—	—	—	ns	See parameter DO31
SP35	TscH2doV, TscL2doV	SDOx Data Output Valid after SCKx Edge	—	—	30	ns	—
SP40	TdiV2scH, TdiV2scL	Setup Time of SDIx Data Input to SCKx Edge	20	—	—	ns	—
SP41	TscH2diL, TscL2diL	Hold Time of SDIx Data Input to SCKx Edge	20	—	—	ns	—
SP50	TssL2scH, TssL2scL	SSx↓ to SCKx↑ or SCKx↓ Input	120	—	—	ns	—
SP51	TssH2doZ	SSx↑ to SDOx Output High-Impedance ⁽³⁾	10	—	50	ns	—
SP52	Tsch2ssH TscL2ssH	SSx after SCK Edge	1.5 Tcy + 40	—	—	ns	—

Note 1: These parameters are characterized but not tested in manufacturing.

Note 2: Data in “Typ” column is at 5V, 25°C unless otherwise stated. Parameters are for design guidance only and are not tested.

Note 3: Assumes 50 pF load on all SPI pins.

FIGURE 24-19: SPI MODULE SLAVE MODE (CKE = 1) TIMING CHARACTERISTICS

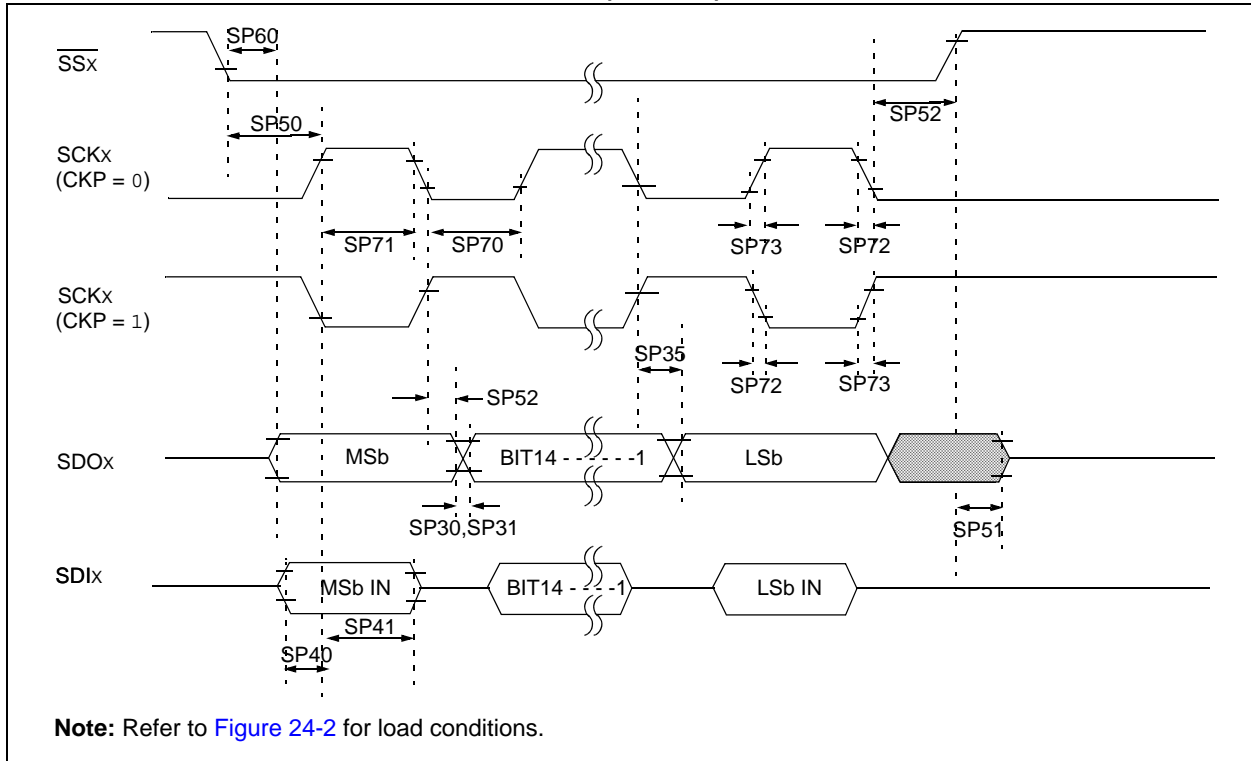

dsPIC30F5015/5016

TABLE 24-36: SPI MODULE SLAVE MODE (CKE = 1) TIMING REQUIREMENTS

AC CHARACTERISTICS			Standard Operating Conditions: 2.5V to 5.5V (unless otherwise stated) Operating temperature -40°C ≤TA ≤+85°C for Industrial -40°C ≤TA ≤+125°C for Extended				
Param No.	Symbol	Characteristic ⁽¹⁾	Min	Typ ⁽²⁾	Max	Units	Conditions
SP70	TscL	SCKx Input Low Time	30	—	—	ns	—
SP71	TscH	SCKx Input High Time	30	—	—	ns	—
SP72	TscF	SCKx Input Fall Time ⁽³⁾	—	10	25	ns	—
SP73	TscR	SCKx Input Rise Time ⁽³⁾	—	10	25	ns	—
SP30	TdoF	SDOx Data Output Fall Time ⁽³⁾	—	—	—	ns	See parameter DO32
SP31	TdoR	SDOx Data Output Rise Time ⁽³⁾	—	—	—	ns	See parameter DO31
SP35	Tsch2doV, TscL2doV	SDOx Data Output Valid after SCKx Edge	—	—	30	ns	—
SP40	TdiV2sch, TdiV2scL	Setup Time of SDIx Data Input to SCKx Edge	20	—	—	ns	—
SP41	Tsch2diL, TscL2diL	Hold Time of SDIx Data Input to SCKx Edge	20	—	—	ns	—
SP50	TssL2sch, TssL2scL	\overline{SSx} ↓ to SCKx↓ or SCKx↑ input	120	—	—	ns	—
SP51	TssH2doZ	\overline{SS} ↑ to SDOx Output High-Impedance ⁽⁴⁾	10	—	50	ns	—
SP52	Tsch2ssH TscL2ssH	\overline{SSx} ↑ after SCKx Edge	1.5 Tcy + 40	—	—	ns	—
SP60	TssL2doV	SDOx Data Output Valid after \overline{SSx} Edge	—	—	50	ns	—

- Note 1:** These parameters are characterized but not tested in manufacturing.
- 2:** Data in “Typ” column is at 5V, 25°C unless otherwise stated. Parameters are for design guidance only and are not tested.
- 3:** The minimum clock period for SCK is 100 ns. Therefore, the clock generated in Master mode must not violate this specification.
- 4:** Assumes 50 pF load on all SPI pins.

FIGURE 24-20: I²C™ BUS START/STOP BITS TIMING CHARACTERISTICS (MASTER MODE)

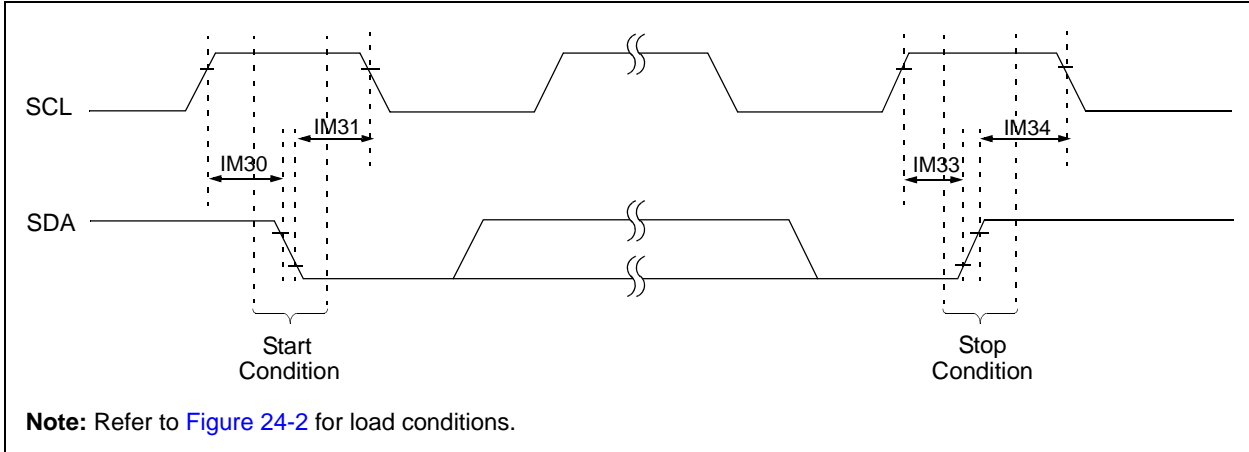
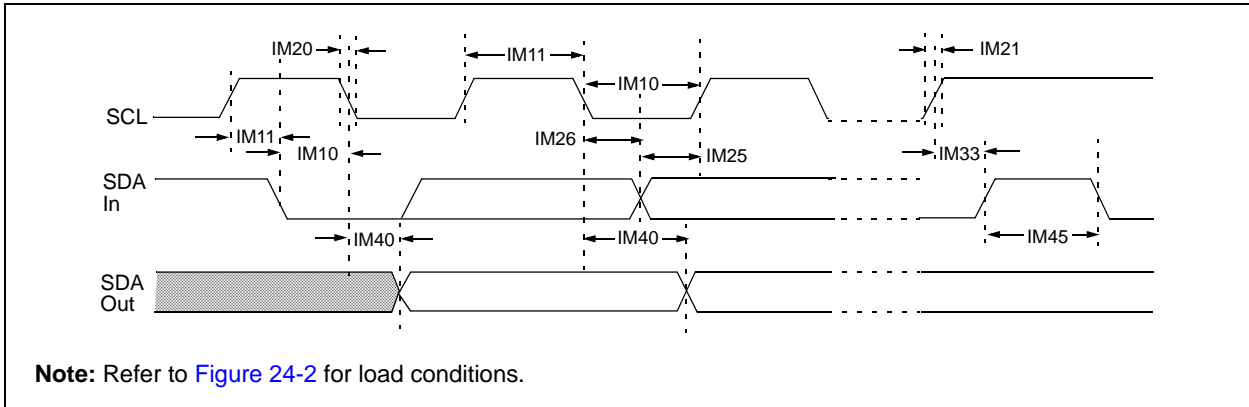

FIGURE 24-21: I²C™ BUS DATA TIMING CHARACTERISTICS (MASTER MODE)



dsPIC30F5015/5016

TABLE 24-37: I²C™ BUS DATA TIMING REQUIREMENTS (MASTER MODE)

AC CHARACTERISTICS			Standard Operating Conditions: 2.5V to 5.5V (unless otherwise stated) Operating temperature -40°C ≤ TA ≤ +85°C for Industrial -40°C ≤ TA ≤ +125°C for Extended				
Param No.	Symbol	Characteristic	Min ⁽¹⁾	Max	Units	Conditions	
IM10	TLO:SCL	Clock Low Time	100 kHz mode	T _{CY} /2 (BRG + 1)	—	μs	—
			400 kHz mode	T _{CY} /2 (BRG + 1)	—	μs	—
			1 MHz mode ⁽²⁾	T _{CY} /2 (BRG + 1)	—	μs	—
IM11	THI:SCL	Clock High Time	100 kHz mode	T _{CY} /2 (BRG + 1)	—	μs	—
			400 kHz mode	T _{CY} /2 (BRG + 1)	—	μs	—
			1 MHz mode ⁽²⁾	T _{CY} /2 (BRG + 1)	—	μs	—
IM20	TF:SCL	SDA and SCL Fall Time	100 kHz mode	—	300	ns	C _B is specified to be from 10 to 400 pF
			400 kHz mode	20 + 0.1 C _B	300	ns	
			1 MHz mode ⁽²⁾	—	100	ns	
IM21	TR:SCL	SDA and SCL Rise Time	100 kHz mode	—	1000	ns	C _B is specified to be from 10 to 400 pF
			400 kHz mode	20 + 0.1 C _B	300	ns	
			1 MHz mode ⁽²⁾	—	300	ns	
IM25	TSU:DAT	Data Input Setup Time	100 kHz mode	250	—	ns	—
			400 kHz mode	100	—	ns	
			1 MHz mode ⁽²⁾	—	—	ns	
IM26	THD:DAT	Data Input Hold Time	100 kHz mode	0	—	ns	—
			400 kHz mode	0	0.9	μs	
			1 MHz mode ⁽²⁾	—	—	ns	
IM30	TSU:STA	Start Condition Setup Time	100 kHz mode	T _{CY} /2 (BRG + 1)	—	μs	Only relevant for repeated Start condition
			400 kHz mode	T _{CY} /2 (BRG + 1)	—	μs	
			1 MHz mode ⁽²⁾	T _{CY} /2 (BRG + 1)	—	μs	
IM31	THD:STA	Start Condition Hold Time	100 kHz mode	T _{CY} /2 (BRG + 1)	—	μs	After this period the first clock pulse is generated
			400 kHz mode	T _{CY} /2 (BRG + 1)	—	μs	
			1 MHz mode ⁽²⁾	T _{CY} /2 (BRG + 1)	—	μs	
IM33	TSU:STO	Stop Condition Setup Time	100 kHz mode	T _{CY} /2 (BRG + 1)	—	μs	—
			400 kHz mode	T _{CY} /2 (BRG + 1)	—	μs	
			1 MHz mode ⁽²⁾	T _{CY} /2 (BRG + 1)	—	μs	
IM34	THD:STO	Stop Condition Hold Time	100 kHz mode	T _{CY} /2 (BRG + 1)	—	ns	—
			400 kHz mode	T _{CY} /2 (BRG + 1)	—	ns	
			1 MHz mode ⁽²⁾	T _{CY} /2 (BRG + 1)	—	ns	
IM40	TAA:SCL	Output Valid From Clock	100 kHz mode	—	3500	ns	—
			400 kHz mode	—	1000	ns	
			1 MHz mode ⁽²⁾	—	—	ns	
IM45	TBF:SDA	Bus Free Time	100 kHz mode	4.7	—	μs	Time the bus must be free before a new transmission can start
			400 kHz mode	1.3	—	μs	
			1 MHz mode ⁽²⁾	—	—	μs	
IM50	CB	Bus Capacitive Loading	—	400	pF	—	

Note 1: BRG is the value of the I²C Baud Rate Generator. Refer to **Section 21. “Inter-Integrated Circuit (I²C™)”** (DS70046) in the “dsPIC30F Family Reference Manual”.

2: Maximum pin capacitance = 10 pF for all I²C pins (for 1 MHz mode only).

FIGURE 24-22: I²C™ BUS START/STOP BITS TIMING CHARACTERISTICS (SLAVE MODE)

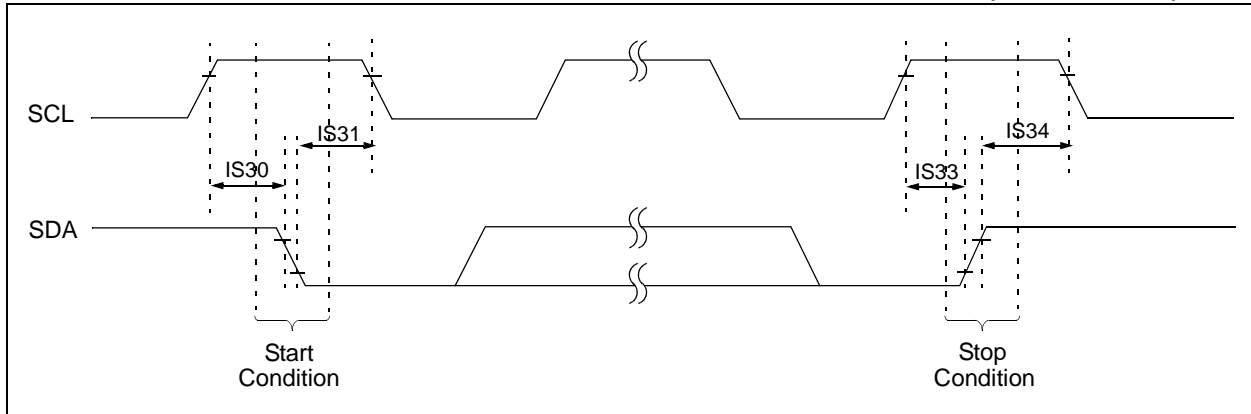
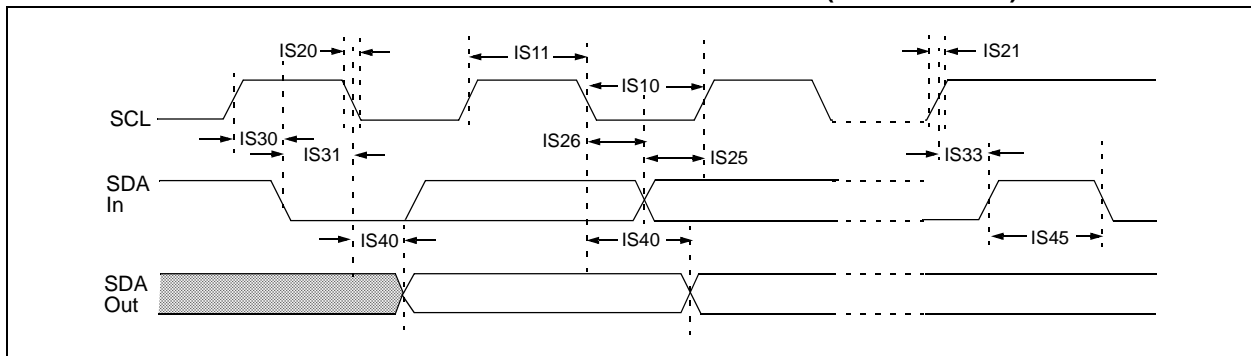

FIGURE 24-23: I²C™ BUS DATA TIMING CHARACTERISTICS (SLAVE MODE)



dsPIC30F5015/5016

TABLE 24-38: I²C™ BUS DATA TIMING REQUIREMENTS (SLAVE MODE)

AC CHARACTERISTICS		Standard Operating Conditions: 2.5V to 5.5V (unless otherwise stated) Operating temperature -40°C ≤TA ≤+85°C for Industrial -40°C ≤TA ≤+125°C for Extended					
Param No.	Symbol	Characteristic		Min	Max	Units	Conditions
IS10	TLO:SCL	Clock Low Time	100 kHz mode	4.7	—	μs	Device must operate at a minimum of 1.5 MHz
			400 kHz mode	1.3	—	μs	Device must operate at a minimum of 10 MHz
			1 MHz mode ⁽¹⁾	0.5	—	μs	—
IS11	THI:SCL	Clock High Time	100 kHz mode	4.0	—	μs	Device must operate at a minimum of 1.5 MHz
			400 kHz mode	0.6	—	μs	Device must operate at a minimum of 10 MHz
			1 MHz mode ⁽¹⁾	0.5	—	μs	—
IS20	TF:SCL	SDA and SCL Fall Time	100 kHz mode	—	300	ns	Cb is specified to be from 10 to 400 pF
			400 kHz mode	20 + 0.1 Cb	300	ns	
			1 MHz mode ⁽¹⁾	—	100	ns	
IS21	TR:SCL	SDA and SCL Rise Time	100 kHz mode	—	1000	ns	Cb is specified to be from 10 to 400 pF
			400 kHz mode	20 + 0.1 Cb	300	ns	
			1 MHz mode ⁽¹⁾	—	300	ns	
IS25	TSU:DAT	Data Input Setup Time	100 kHz mode	250	—	ns	—
			400 kHz mode	100	—	ns	
			1 MHz mode ⁽¹⁾	100	—	ns	
IS26	THD:DAT	Data Input Hold Time	100 kHz mode	0	—	ns	—
			400 kHz mode	0	0.9	μs	
			1 MHz mode ⁽¹⁾	0	0.3	μs	
IS30	TSU:STA	Start Condition Setup Time	100 kHz mode	4.7	—	μs	Only relevant for repeated Start condition
			400 kHz mode	0.6	—	μs	
			1 MHz mode ⁽¹⁾	0.25	—	μs	
IS31	THD:STA	Start Condition Hold Time	100 kHz mode	4.0	—	μs	After this period, the first clock pulse is generated
			400 kHz mode	0.6	—	μs	
			1 MHz mode ⁽¹⁾	0.25	—	μs	
IS33	TSU:STO	Stop Condition Setup Time	100 kHz mode	4.7	—	μs	—
			400 kHz mode	0.6	—	μs	
			1 MHz mode ⁽¹⁾	0.6	—	μs	
IS34	THD:STO	Stop Condition Hold Time	100 kHz mode	4000	—	ns	—
			400 kHz mode	600	—	ns	
			1 MHz mode ⁽¹⁾	250	—	ns	
IS40	TAA:SCL	Output Valid From Clock	100 kHz mode	0	3500	ns	—
			400 kHz mode	0	1000	ns	
			1 MHz mode ⁽¹⁾	0	350	ns	
IS45	TBF:SDA	Bus Free Time	100 kHz mode	4.7	—	μs	Time the bus must be free before a new transmission can start
			400 kHz mode	1.3	—	μs	
			1 MHz mode ⁽¹⁾	0.5	—	μs	

Note 1: Maximum pin capacitance = 10 pF for all I²C pins (for 1 MHz mode only).

TABLE 24-38: I²C™ BUS DATA TIMING REQUIREMENTS (SLAVE MODE)

AC CHARACTERISTICS		Standard Operating Conditions: 2.5V to 5.5V (unless otherwise stated) Operating temperature -40°C ≤TA ≤+85°C for Industrial -40°C ≤TA ≤+125°C for Extended				
Param No.	Symbol	Characteristic	Min	Max	Units	Conditions
IS50	CB	Bus Capacitive Loading	—	400	pF	—

Note 1: Maximum pin capacitance = 10 pF for all I²C pins (for 1 MHz mode only).

FIGURE 24-24: CAN MODULE I/O TIMING CHARACTERISTICS

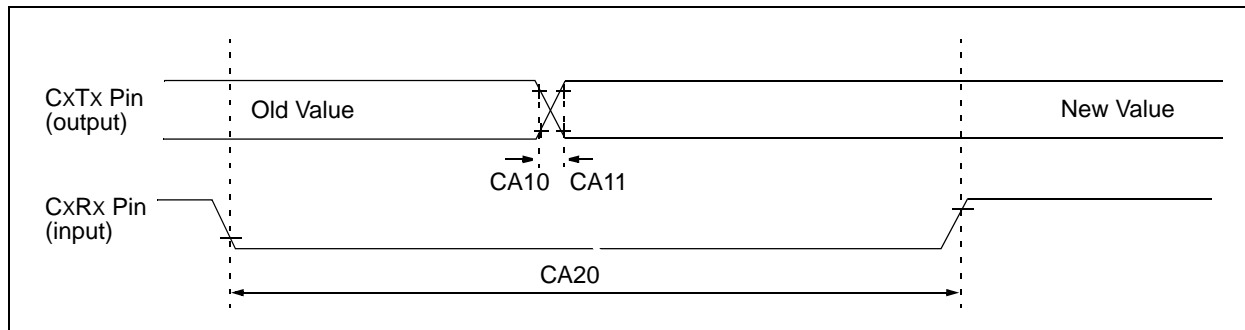

TABLE 24-39: CAN MODULE I/O TIMING REQUIREMENTS

AC CHARACTERISTICS		Standard Operating Conditions: 2.5V to 5.5V (unless otherwise stated) Operating temperature -40°C ≤TA ≤+85°C for Industrial -40°C ≤TA ≤+125°C for Extended					
Param No.	Symbol	Characteristic ⁽¹⁾	Min	Typ ⁽²⁾	Max	Units	Conditions
CA10	TioF	Port Output Fall Time	—	—	—	ns	See parameter DO32
CA11	TioR	Port Output Rise Time	—	—	—	ns	See parameter DO31
CA20	Tcwf	Pulse Width to Trigger CAN Wake-up Filter	500	—	—	ns	—

Note 1: These parameters are characterized but not tested in manufacturing.

Note 2: Data in “Typ” column is at 5V, 25°C unless otherwise stated. Parameters are for design guidance only and are not tested.

dsPIC30F5015/5016

TABLE 24-40: 10-BIT HIGH-SPEED A/D MODULE SPECIFICATIONS⁽¹⁾

AC CHARACTERISTICS			Standard Operating Conditions: 2.7V to 5.5V (unless otherwise stated) Operating temperature $-40^{\circ}\text{C} \leq T_A \leq +85^{\circ}\text{C}$ for Industrial $-40^{\circ}\text{C} \leq T_A \leq +125^{\circ}\text{C}$ for Extended				
Param No.	Symbol	Characteristic	Min.	Typ	Max.	Units	Conditions
Device Supply							
AD01	AVDD	Module VDD Supply	Greater of VDD – 0.3 or 2.7	—	Lesser of VDD + 0.3 or 5.5	V	
AD02	AVSS	Module Vss Supply	Vss – 0.3	—	Vss + 0.3	V	
Reference Inputs							
AD05	VREFH	Reference Voltage High	AVss + 2.7	—	AVDD	V	
AD06	VREFL	Reference Voltage Low	AVss	—	AVDD – 2.7	V	
AD07	VREF	Absolute Reference Voltage	AVss – 0.3	—	AVDD + 0.3	V	
AD08	IREF	Current Drain	—	200 .001	300 3	μA μA	A/D operating A/D off
Analog Input							
AD10	VINH-VINL	Full-Scale Input Span	VREFL	—	VREFH	V	
AD12	—	Leakage Current	—	± 0.001	± 0.244	μA	VINL = AVSS = VREFL = 0V, AVDD = VREFH = 5V Source Impedance = 5 k Ω
AD13	—	Leakage Current	—	± 0.001	± 0.244	μA	VINL = AVSS = VREFL = 0V, AVDD = VREFH = 3V Source Impedance = 5 k Ω
AD17	RIN	Recommended Impedance of Analog Voltage Source	—	—	—	Ω	See Table 20-2
DC Accuracy							
AD20	Nr	Resolution	10 data bits			bits	—
AD21	INL	Integral Nonlinearity ⁽²⁾	—	± 1	± 1	LSb	VINL = AVSS = VREFL = 0V, AVDD = VREFH = 5V
AD21A	INL	Integral Nonlinearity ⁽²⁾	—	± 1	± 1	LSb	VINL = AVSS = VREFL = 0V, AVDD = VREFH = 3V
AD22	DNL	Differential Nonlinearity ⁽²⁾	—	± 1	± 1	LSb	VINL = AVSS = VREFL = 0V, AVDD = VREFH = 5V
AD22A	DNL	Differential Nonlinearity ⁽²⁾	—	± 1	± 1	LSb	VINL = AVSS = VREFL = 0V, AVDD = VREFH = 3V
AD23	GERR	Gain Error ⁽²⁾	—	± 5	± 6	LSb	VINL = AVSS = VREFL = 0V, AVDD = VREFH = 5V
AD23A	GERR	Gain Error ⁽²⁾	—	± 5	± 6	LSb	VINL = AVSS = VREFL = 0V, AVDD = VREFH = 3V

Note 1: These parameters are characterized but not tested in manufacturing.

2: Measurements taken with external VREF+ and VREF- used as the ADC voltage references.

3: The A/D conversion result never decreases with an increase in the input voltage, and has no missing codes.

TABLE 24-40: 10-BIT HIGH-SPEED A/D MODULE SPECIFICATIONS⁽¹⁾ (CONTINUED)

AC CHARACTERISTICS			Standard Operating Conditions: 2.7V to 5.5V (unless otherwise stated) Operating temperature -40°C ≤ TA ≤ +85°C for Industrial -40°C ≤ TA ≤ +125°C for Extended				
Param No.	Symbol	Characteristic	Min.	Typ	Max.	Units	Conditions
AD24	E _{OFF}	Offset Error ⁽²⁾	±1	±2	±3	LSb	V _{INL} = AV _{SS} = V _{REFL} = 0V, AV _{DD} = V _{REFH} = 5V
AD24A	E _{OFF}	Offset Error ⁽²⁾	±1	±2	±3	LSb	V _{INL} = AV _{SS} = V _{REFL} = 0V, AV _{DD} = V _{REFH} = 3V
AD25	—	Monotonicity ⁽³⁾	—	—	—	—	Guaranteed
Dynamic Performance							
AD30	THD	Total Harmonic Distortion	—	-64	-67	dB	—
AD31	SINAD	Signal to Noise and Distortion	—	57	58	dB	—
AD32	SFDR	Spurious Free Dynamic Range	—	67	71	dB	—
AD33	F _{NYQ}	Input Signal Bandwidth	—	—	500	kHz	—
AD34	ENOB	Effective Number of Bits	9.29	9.41	—	bits	—

- Note 1:** These parameters are characterized but not tested in manufacturing.
Note 2: Measurements taken with external V_{REF+} and V_{REF-} used as the ADC voltage references.
Note 3: The A/D conversion result never decreases with an increase in the input voltage, and has no missing codes.

dsPIC30F5015/5016

FIGURE 24-25: 10-BIT HIGH-SPEED A/D CONVERSION TIMING CHARACTERISTICS
(CHPS = 01, SIMSAM = 0, ASAM = 0, SSRC = 000)

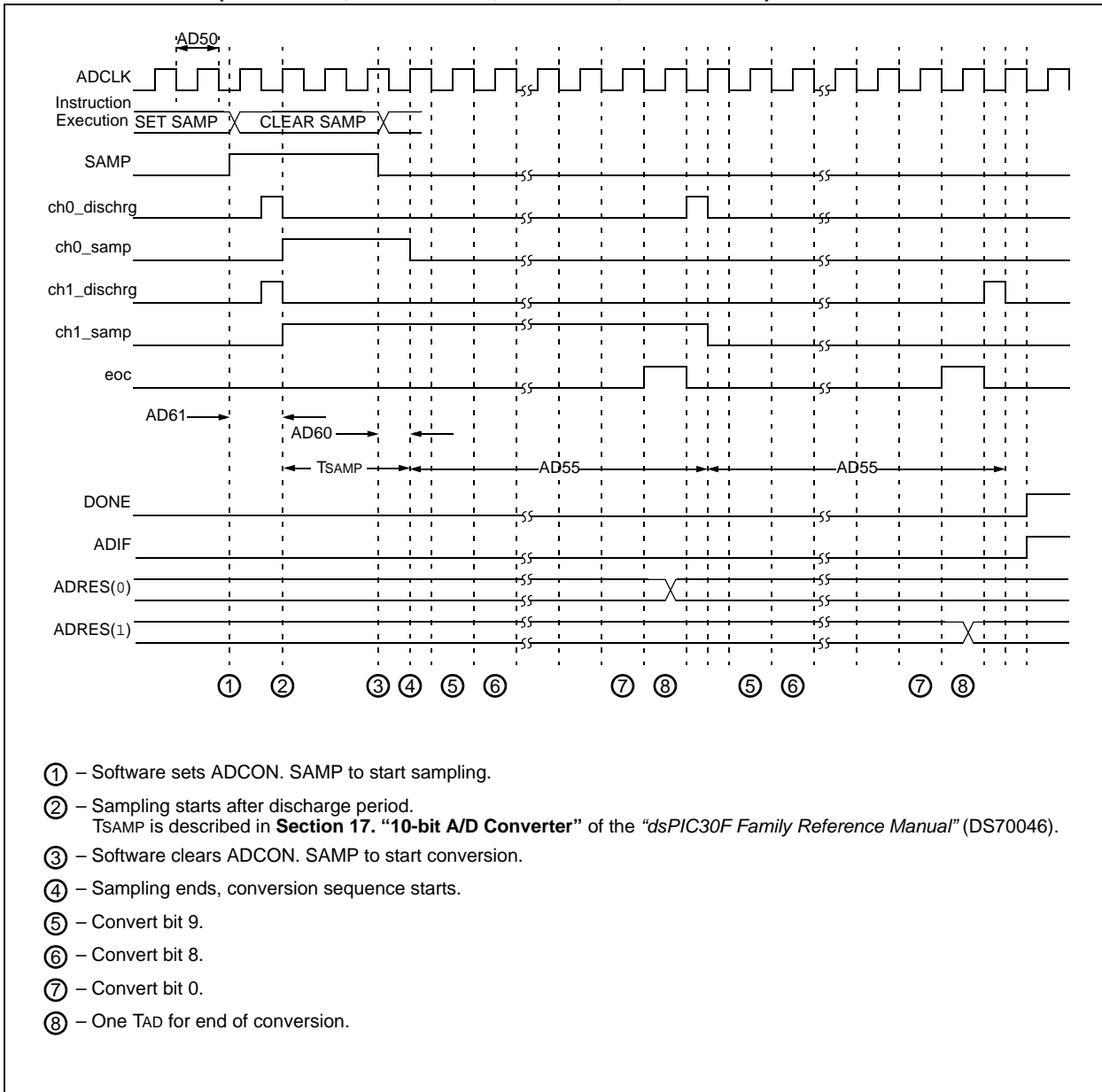
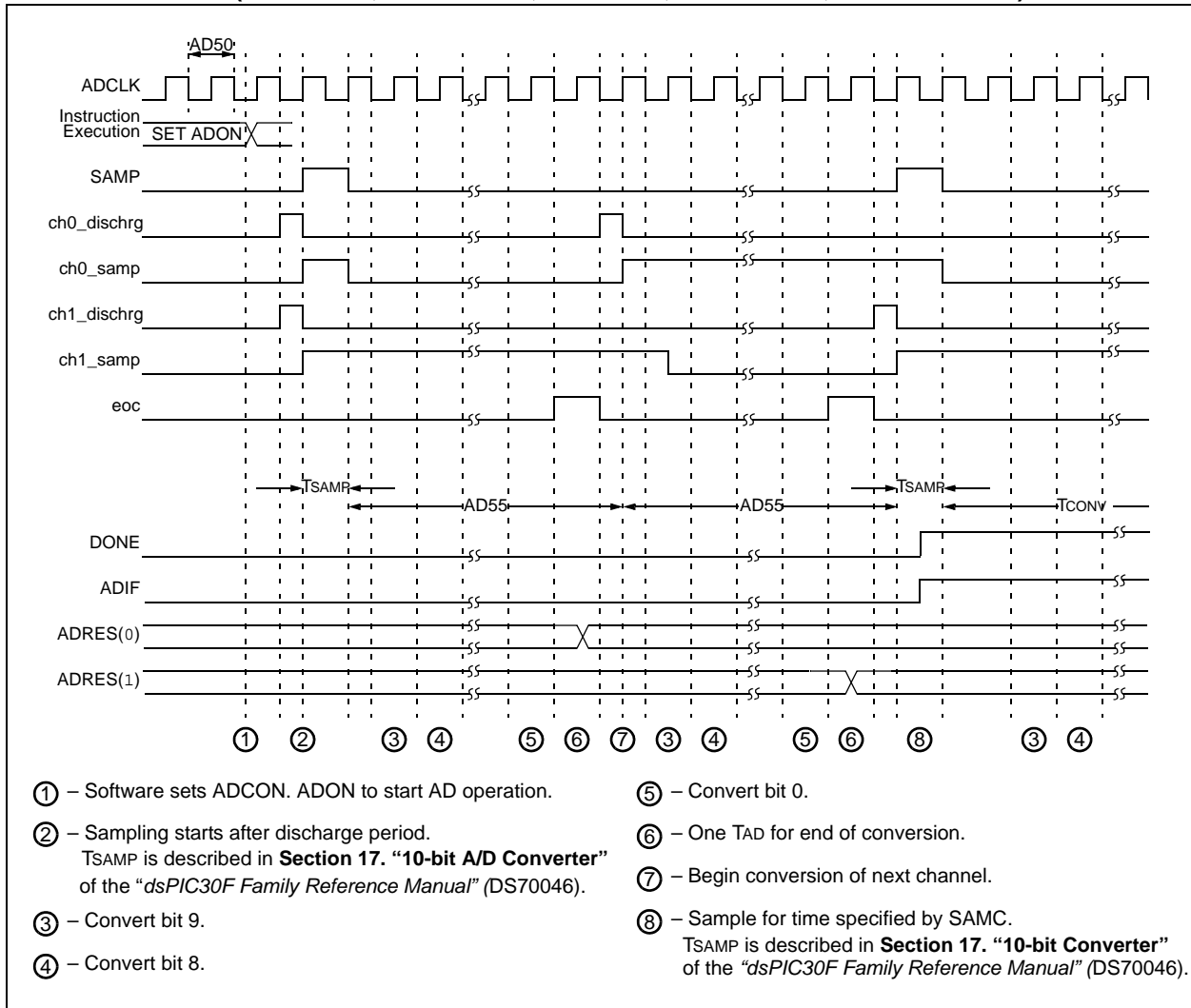

FIGURE 24-26: 10-BIT HIGH-SPEED A/D CONVERSION TIMING CHARACTERISTICS
(CHPS = 01, SIMSAM = 0, ASAM = 1, SSRC = 111, SAMC = 00001)



dsPIC30F5015/5016

TABLE 24-41: 10-BIT HIGH-SPEED A/D CONVERSION TIMING REQUIREMENTS

AC CHARACTERISTICS			Standard Operating Conditions: 2.7V to 5.5V (unless otherwise stated) Operating temperature -40°C ≤TA ≤+85°C for Industrial -40°C ≤TA ≤+125°C for Extended				
Param No.	Symbol	Characteristic	Min.	Typ ⁽¹⁾	Max.	Units	Conditions
Clock Parameters							
AD50	TAD	A/D Clock Period	—	83.33 ⁽²⁾	—	ns	See Table 20-1 ⁽³⁾
AD51	tRC	A/D Internal RC Oscillator Period	700	900	1100	ns	—
Conversion Rate							
AD55	tCONV	Conversion Time	—	12 TAD	—	—	—
AD56	FCNV	Throughput Rate	—	1.0	—	Msp/s	See Table 20-1 ⁽³⁾
AD57	TSAMP	Sample Time	—	1 TAD	—	—	See Table 20-1 ⁽³⁾
Timing Parameters							
AD60	tPCS	Conversion Start from Sample Trigger ⁽³⁾	—	1.0 TAD	—	—	Auto-Convert Trigger (SSRC = 111) not selected
AD61	tPSS	Sample Start from Setting Sample (SAMP) Bit	0.5 TAD	—	1.5 TAD	—	—
AD62	tCSS	Conversion Completion to Sample Start (ASAM = 1) ⁽⁴⁾	—	0.5 TAD	—	ns	—
AD63	tDPU ⁽⁴⁾	Time to Stabilize Analog Stage from A/D Off to A/D On ⁽⁴⁾	—	—	20	μs	—

- Note 1:** These parameters are characterized but not tested in manufacturing.
- Note 2:** Operating Temperature: -40°C to +85°C
- Note 3:** Because the sample caps will eventually lose charge, clock rates below 10 kHz can affect linearity performance, especially at elevated temperatures.
- Note 4:** tDPU is the time required for the ADC module to stabilize when it is turned on (ADCON1<ADON> = 1). During this time the ADC result is indeterminate.

25.0 PACKAGING INFORMATION

25.1 Package Marking Information

64-Lead TQFP

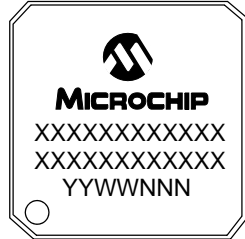

Example

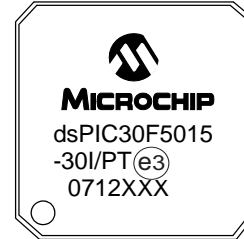

80-Lead TQFP

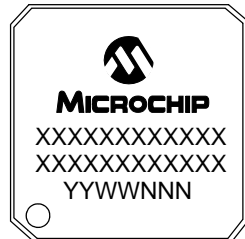

Example

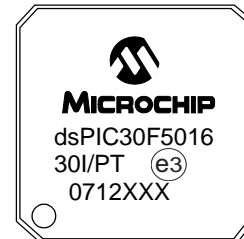

Legend:	XX...X	Customer-specific information
	Y	Year code (last digit of calendar year)
	YY	Year code (last 2 digits of calendar year)
	WW	Week code (week of January 1 is week '01')
	NNN	Alphanumeric traceability code
	(e3)	Pb-free JEDEC designator for Matte Tin (Sn)
	*	This package is Pb-free. The Pb-free JEDEC designator (e3) can be found on the outer packaging for this package.

Note: In the event the full Microchip part number cannot be marked on one line, it will be carried over to the next line, thus limiting the number of available characters for customer-specific information.

dsPIC30F5015/5016

64-Lead Plastic Thin Quad Flatpack (PT) – 10x10x1 mm Body, 2.00 mm Footprint [TQFP]

Note: For the most current package drawings, please see the Microchip Packaging Specification located at <http://www.microchip.com/packaging>

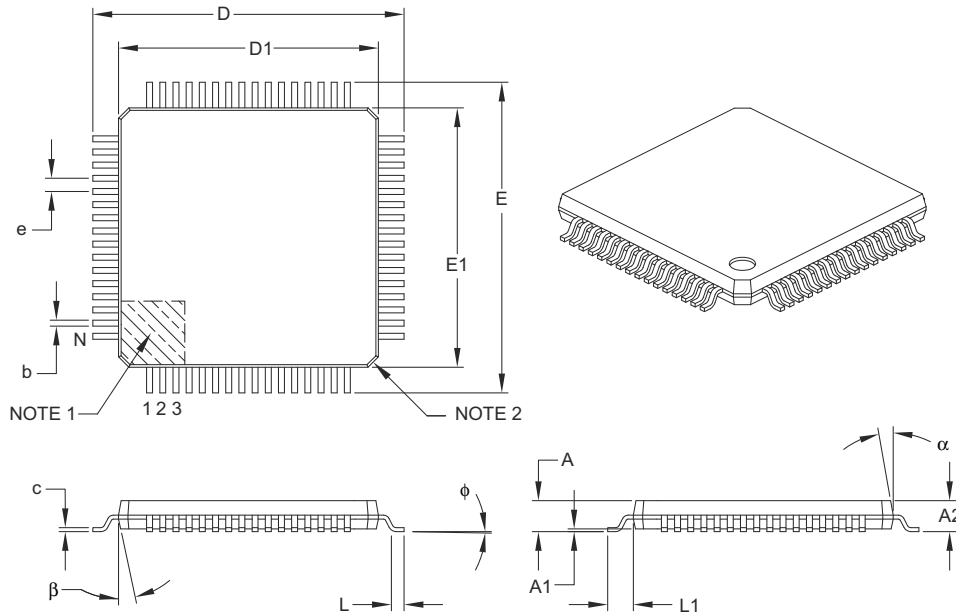

		Units	MILLIMETERS		
Dimension Limits			MIN	NOM	MAX
Number of Leads	N		64		
Lead Pitch	e		0.50 BSC		
Overall Height	A	–	–		1.20
Molded Package Thickness	A2		0.95	1.00	1.05
Standoff	A1		0.05	–	0.15
Foot Length	L		0.45	0.60	0.75
Footprint	L1		1.00 REF		
Foot Angle	φ		0°	3.5°	7°
Overall Width	E		12.00 BSC		
Overall Length	D		12.00 BSC		
Molded Package Width	E1		10.00 BSC		
Molded Package Length	D1		10.00 BSC		
Lead Thickness	c		0.09	–	0.20
Lead Width	b		0.17	0.22	0.27
Mold Draft Angle Top	α		11°	12°	13°
Mold Draft Angle Bottom	β		11°	12°	13°

Notes:

- Pin 1 visual index feature may vary, but must be located within the hatched area.
- Chamfers at corners are optional; size may vary.
- Dimensions D1 and E1 do not include mold flash or protrusions. Mold flash or protrusions shall not exceed 0.25 mm per side.
- Dimensioning and tolerancing per ASME Y14.5M.

BSC: Basic Dimension. Theoretically exact value shown without tolerances.

REF: Reference Dimension, usually without tolerance, for information purposes only.

Microchip Technology Drawing C04-085B

64-Lead Plastic Thin Quad Flatpack (PT) – 10x10x1 mm Body, 2.00 mm [TQFP]

Note: For the most current package drawings, please see the Microchip Packaging Specification located at <http://www.microchip.com/packaging>

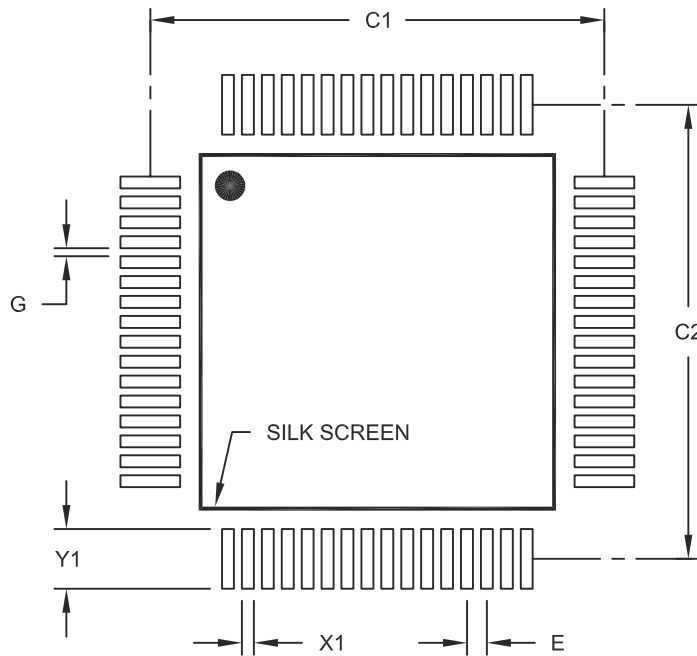

RECOMMENDED LAND PATTERN

		Units	MILLIMETERS		
		Dimension Limits	MIN	NOM	MAX
Contact Pitch	E		0.50 BSC		
Contact Pad Spacing	C1			11.40	
Contact Pad Spacing	C2			11.40	
Contact Pad Width (X64)	X1				0.30
Contact Pad Length (X64)	Y1				1.50
Distance Between Pads	G	0.20			

Notes:

1. Dimensioning and tolerancing per ASME Y14.5M

BSC: Basic Dimension. Theoretically exact value shown without tolerances.

Microchip Technology Drawing No. C04-2085A

dsPIC30F5015/5016

80-Lead Plastic Thin Quad Flatpack (PT) – 12x12x1 mm Body, 2.00 mm Footprint [TQFP]

Note: For the most current package drawings, please see the Microchip Packaging Specification located at <http://www.microchip.com/packaging>

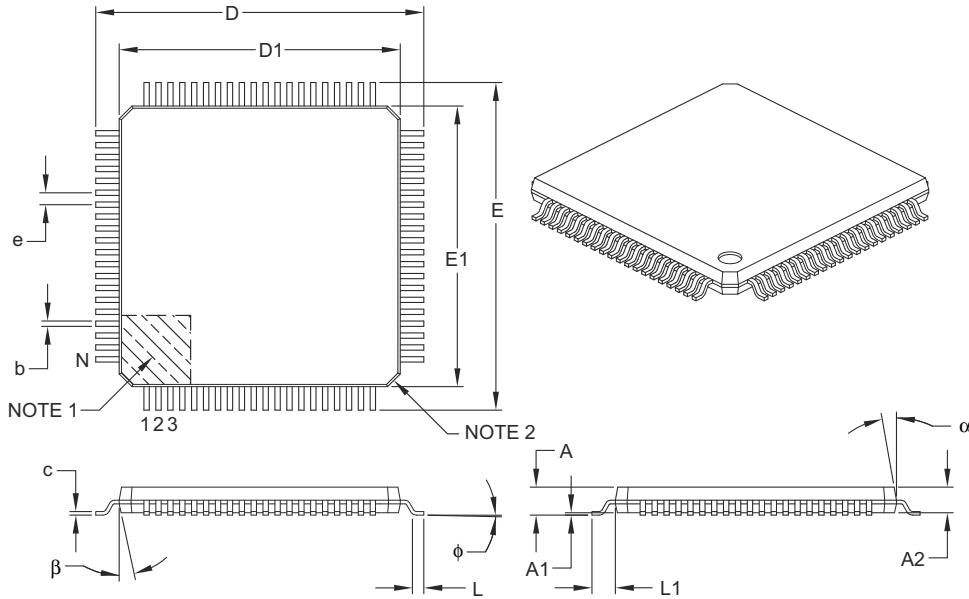

Dimension Limits	Units	MILLIMETERS		
		MIN	NOM	MAX
Number of Leads	N	80		
Lead Pitch	e	0.50 BSC		
Overall Height	A	–	–	1.20
Molded Package Thickness	A2	0.95	1.00	1.05
Standoff	A1	0.05	–	0.15
Foot Length	L	0.45	0.60	0.75
Footprint	L1	1.00 REF		
Foot Angle	ϕ	0°	3.5°	7°
Overall Width	E	14.00 BSC		
Overall Length	D	14.00 BSC		
Molded Package Width	E1	12.00 BSC		
Molded Package Length	D1	12.00 BSC		
Lead Thickness	c	0.09	–	0.20
Lead Width	b	0.17	0.22	0.27
Mold Draft Angle Top	α	11°	12°	13°
Mold Draft Angle Bottom	β	11°	12°	13°

Notes:

- Pin 1 visual index feature may vary, but must be located within the hatched area.
- Chamfers at corners are optional; size may vary.
- Dimensions D1 and E1 do not include mold flash or protrusions. Mold flash or protrusions shall not exceed 0.25 mm per side.
- Dimensioning and tolerancing per ASME Y14.5M.

BSC: Basic Dimension. Theoretically exact value shown without tolerances.

REF: Reference Dimension, usually without tolerance, for information purposes only.

Microchip Technology Drawing C04-092B

dsPIC30F5015/5016

80-Lead Plastic Thin Quad Flatpack (PT) – 12x12x1 mm Body, 2.00 mm [TQFP]

Note: For the most current package drawings, please see the Microchip Packaging Specification located at <http://www.microchip.com/packaging>

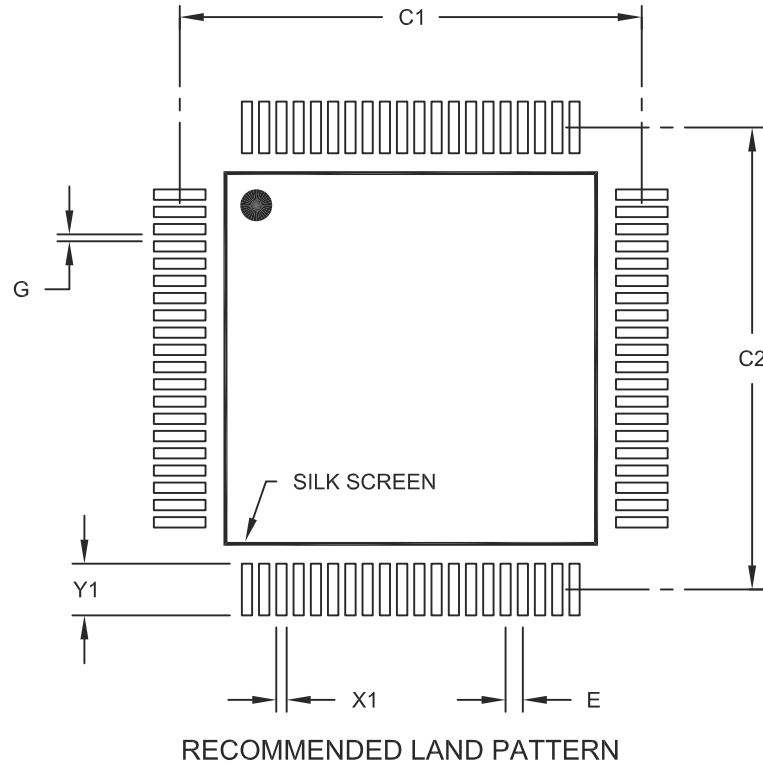

Dimension Limits	Units	MILLIMETERS		
		MIN	NOM	MAX
Contact Pitch	E	0.50 BSC		
Contact Pad Spacing	C1		13.40	
Contact Pad Spacing	C2		13.40	
Contact Pad Width (X80)	X1			0.30
Contact Pad Length (X80)	Y1			1.50
Distance Between Pads	G	0.20		

Notes:

1. Dimensioning and tolerancing per ASME Y14.5M

BSC: Basic Dimension. Theoretically exact value shown without tolerances.

Microchip Technology Drawing No. C04-2092A

dsPIC30F5015/5016

NOTES:

APPENDIX A: REVISION HISTORY

Revision A (July 2005)

Original data sheet for dsPIC30F5015/5016 devices.

Revision B (September 2006)

Revision B of this data sheet reflects these changes:

- Base instruction CP1 removed (see [Table 22-2](#))
- Supported I²C Slave Addresses (see [Table 17-1](#))
- ADC Conversion Clock selection (see [Section 20.0 “10-bit High-Speed Analog-to-Digital Converter \(ADC\) Module”](#))
- Revised Electrical Characteristics
 - Operating current (IDD) specifications (see [Table 24-6](#))
 - Idle current (IDLE) specifications (see [Table 24-7](#))
 - Power-down current (IPD) specifications (see [Table 24-8](#))
 - I/O Pin input specifications (see [Table 24-9](#))
 - BOR voltage limits (see [Table 24-11](#))
 - Watchdog Timer limits (see [Table 24-21](#))

Revision C (January 2007)

This revision includes updates to the packaging diagram.

Revision D (March 2008)

This revision reflects these updates:

- Changed the location of the input reference in the 10-bit High-Speed ADC Functional Block Diagram (see [Figure 20-1](#))
- Added FUSE Configuration Register (FICD) details (see [Section 21.6 “Device Configuration Registers”](#) and [Table 21-8](#))
- Added Note 2 in Device Configuration Registers table ([Table 21-8](#))
- Removed erroneous statement regarding generation of CAN receive errors (see [Section 19.4.5 “Receive Errors”](#))
- Electrical Specifications:
 - Resolved TBD values for parameters DO10, DO16, DO20, and DO26 (see [Table 24-10](#))
 - 10-bit High-Speed ADC tPDU timing parameter (time to stabilize) has been updated from 20 μs typical to 20 μs maximum (see [Table 24-41](#))
 - Parameter OS65 (Internal RC Accuracy) has been expanded to reflect multiple Min and Max values for different temperatures (see [Table 24-19](#))
 - Parameter DC12 (RAM Data Retention Voltage) Min and Max values have been updated (see [Table 24-5](#))
 - Parameter D134 (Erase/Write Cycle Time) has been updated to include Min and Max values and the Typ value has been removed (see [Table 24-12](#))
 - Removed parameters OS62 (Internal FRC Jitter) and OS64 (Internal FRC Drift) and Note 2 from AC Characteristics (see [Table 24-18](#))
 - Parameter OS63 (Internal FRC Accuracy) has been expanded to reflect multiple Min and Max values for different temperatures (see [Table 24-18](#))
 - Updated Min and Max values and Conditions for parameter SY11 and updated Min, Typ, and Max values and Conditions for parameter SY20 (see [Table 24-21](#))
- Removed dsPIC30F6010 device reference from the third paragraph of [Section 7.0 “Data EEPROM Memory”](#)
- Removed IC5 and IC6 pin references from the 64-pin TQFP pin diagram (see [“Pin Diagram”](#)) and [Figure 1-1](#)
- Changed Interrupt Vectors 40-43 to Reserved (see [Table 5-1](#))
- Updated PMD2 SFR – bits 15-12 and 7-4 are unimplemented (see [Table 21-7](#))
- Additional minor corrections throughout the document

dsPIC30F5015/5016

Revision E (February 2011)

This revision includes minor typographical and formatting changes throughout the data sheet text.

The major changes are referenced by their respective section in [Table A-1](#).

TABLE A-1: MAJOR SECTION UPDATES

Section Name	Update Description
Section 15.0 “Motor Control PWM Module”	Updated the PWM Period equations (see Equation 15-1 and Equation 15-2).
Section 21.0 “System Integration”	Added a shaded note on OSCTUN functionality in Section 21.2.5 “Fast RC Oscillator (FRC)” .
Section 24.0 “Electrical Characteristics”	Updated the maximum value for parameter D119 and the minimum value for parameter D129 in the I/O Pin Input Specifications (see Table 24-9). Removed parameter D136 and updated the minimum, typical, maximum, and conditions for parameters D122 and D134 in the Program and EEPROM specifications (see Table 24-12). Updated Note 1 in the Internal FRC Accuracy specifications (see Table 24-18).

INDEX

A

A/D

Aborting a Conversion	142
Acquisition Requirements	146
ADCHS	139
ADCON1	139
ADCON2	139
ADCON3	139
ADCSSL	139
ADPCFG	139
Configuring Analog Port Pins	148
Connection Considerations	148
Conversion Operation	141
Effects of a Reset	147
Operation During CPU Idle Mode	147
Operation During CPU Sleep Mode	147
Output Formats	147
Power-Down Modes	147
Programming the Start of Conversion Trigger	142
Register Map	149
Result Buffer	141
Selecting the Conversion Clock	142
Selecting the Conversion Sequence	141

AC

Temperature and Voltage Specifications	186
--	-----

AC Characteristics

Internal FRC Jitter, Accuracy and Drift	190
Internal LPRC Accuracy	190
Load Conditions	186
PLL Jitter	188

Address Generator Units

.....	37
-------	----

Alternate Interrupt Vector Table (AIVT)

.....	47
-------	----

Alternate 16-bit Timer/Counter

.....	93
-------	----

Assembler

MPASM Assembler	174
-----------------------	-----

Automatic Clock Stretch

.....	116
-------	-----

During 10-bit Addressing (STREN = 1)	116
--	-----

During 7-bit Addressing (STREN = 1)	116
---	-----

Receive Mode	116
--------------------	-----

Transmit Mode	116
---------------------	-----

B

Barrel Shifter

.....	24
-------	----

Bit-Reversed Addressing

.....	40
-------	----

Example	40
---------------	----

Implementation	40
----------------------	----

Modifier Values for XBREV Register	41
--	----

Sequence Table (16-Entry)	41
---------------------------------	----

Block Diagrams

CAN Buffers and Protocol Engine	130
---------------------------------------	-----

Dedicated Port Structure	61
--------------------------------	----

DSP Engine	21
------------------	----

dsPIC30F5015	10
--------------------	----

dsPIC30F5016	13
--------------------	----

External Power-on Reset Circuit	159
---------------------------------------	-----

Input Capture Mode	81
--------------------------	----

I ² C	114
------------------------	-----

Oscillator System	153
-------------------------	-----

Output Compare Mode	85
---------------------------	----

Programmer's Model	19
--------------------------	----

PWM Module	98
------------------	----

Quadrature Encoder Interface	91
------------------------------------	----

Reset System	157
--------------------	-----

Shared Port Structure	62
-----------------------------	----

SPI	110
-----------	-----

SPI Master/Slave Connection	110
-----------------------------------	-----

UART Receiver	122
---------------------	-----

UART Transmitter	121
------------------------	-----

10-bit High-Speed A/D Functional	140
--	-----

16-bit Timer1 Module (Type A Timer)	68
---	----

16-bit Timer2 (Type B Timer)	73
------------------------------------	----

16-bit Timer3 (Type C Timer)	73
------------------------------------	----

16-bit Timer4 (Type B Timer)	78
------------------------------------	----

16-bit Timer5 (Type C Timer)	78
------------------------------------	----

32-bit Timer2/3	72
-----------------------	----

32-bit Timer4/5	77
-----------------------	----

BOR. See Brown-out Reset.

Brown-out Reset (BOR)	151
-----------------------------	-----

C

C Compilers

MPLAB C18	174
-----------------	-----

CAN

Baud Rate Setting	134
-------------------------	-----

Bit Timing	134
------------------	-----

Message Reception	132
-------------------------	-----

Acceptance Filter Masks	132
-------------------------------	-----

Acceptance Filters	132
--------------------------	-----

Receive Buffers	132
-----------------------	-----

Receive Errors	132
----------------------	-----

Receive Interrupts	132
--------------------------	-----

Receive Overrun	132
-----------------------	-----

Message Transmission	133
----------------------------	-----

Aborting	133
----------------	-----

Errors	133
--------------	-----

Interrupts	134
------------------	-----

Sequence	133
----------------	-----

Transmit Buffers	133
------------------------	-----

Transmit Priority	133
-------------------------	-----

Modes of Operation	131
--------------------------	-----

Disable	131
---------------	-----

Error Recognition	131
-------------------------	-----

Initialization	131
----------------------	-----

Listen-Only	131
-------------------	-----

Loopback	131
----------------	-----

Normal	131
--------------	-----

Phase Segments	135
----------------------	-----

Prescaler Setting	135
-------------------------	-----

Propagation Segment	135
---------------------------	-----

Sample Point	135
--------------------	-----

Synchronization	135
-----------------------	-----

CAN Module	129
------------------	-----

CAN1 Register Map	136
-------------------------	-----

Frame Types	129
-------------------	-----

Overview	129
----------------	-----

Code Examples

Data EEPROM Block Erase	58
-------------------------------	----

Data EEPROM Block Write	60
-------------------------------	----

Data EEPROM Read	57
------------------------	----

Data EEPROM Word Erase	58
------------------------------	----

Data EEPROM Word Write	59
------------------------------	----

Erasing a Row of Program Memory	53
---------------------------------------	----

Initiating a Programming Sequence	54
---	----

Loading Write Latches	54
-----------------------------	----

Code Protection	151
-----------------------	-----

Configuring Analog Port Pins	62
------------------------------------	----

Core

dsPIC30F5015/5016

Register Map	34
Core Overview	17
CPU Architecture Overview	17
Customer Change Notification Service	229
Customer Notification Service	229
Customer Support	229
D	
Data Address Space	29
Alignment	32
Alignment (Figure)	32
Effect of Invalid Memory Accesses	32
MCU and DSP (MAC Class) Instructions Example	31
Memory Map	29, 30
Near Data Space	33
Software Stack	33
Spaces	32
Width	32
Data EEPROM Memory	57
Erasing	58
Erasing, Block	58
Erasing, Word	58
Protection Against Spurious Write	60
Reading	57
Write Verify	60
Writing	59
Writing, Block	60
Writing, Word	59
DC Characteristics	178
I/O Pin Input Specifications	183
I/O Pin Output Specifications	184
Idle Current (IDLE)	181
Operating Current (IDD)	180
Operating MIPS vs Voltage	
dsPIC30F5015	178
dsPIC30F5016	178
Power-Down Current (IPD)	182
Program and EEPROM	185
Temperature and Voltage Specifications	179
Thermal Operating Conditions	178
Development Support	173
Device Configuration	
Register Map	164
Device Configuration Registers	162
FBORPOR	162
FGS	162
FOSC	162
FWDT	162
Device Overview	9
Divide Support	20
DSP Engine	20
Data Accumulators and Adder/Subtractor	22
Accumulator Write Back	23
Data Space Write Saturation	24
Overflow and Saturation	22
Round Logic	23
Multiplier	22
dsPIC30F5015 PORT	
Register Map	63
dsPIC30F5016 PORT	
Register Map	64
Dual Output Compare Match Mode	86
Continuous Pulse Mode	86
Single Pulse Mode	86

E	
Electrical Characteristics	177
Equations	
A/D Conversion Clock	142
Baud Rate	125
PWM Period	100
PWM Period (Up/Down Mode)	100
PWM Resolution	100
Serial Clock Rate	118
Time Quantum for Clock Generation	135
Errata	7
F	
Fast Context Saving	47
Flash Program Memory	51
Erasing a Row	53
Initiating Programming Sequence	54
Loading Write Latches	54
Operations	53
Programming Algorithm	53
Table Instruction Operation Summary	51
I	
I/O Ports	61
Parallel I/O (PIO)	61
Idle Current (IDLE)	181
In-Circuit Debugger	163
In-Circuit Serial Programming (ICSP)	51, 151
Initialization Condition for RCON Register Case 1	160
Initialization Condition for RCON Register Case 2	160
Input Capture Module	81
Interrupts	82
Operation During Sleep and Idle Modes	82
Register Map	83
Simple Capture Event Mode	81
Input Change Notification Module	65
Register Map (Bits 15-8 for dsPIC30F5015)	65
Register Map (Bits 15-8 for dsPIC30F5016)	65
Register Map (Bits 7-0 for dsPIC30F5015)	65
Register Map (Bits 7-0 for dsPIC30F5016)	65
Instruction Addressing Modes	37
File Register Instructions	37
Fundamental Modes Supported	37
MAC Instructions	38
MCU Instructions	37
Move and Accumulator Instructions	38
Other Instructions	38
Instruction Set	
Overview	168
Summary	165
Internet Address	229
Interrupt Vector Table (IVT)	47
Interrupts	43
Controller	
Register Map for dsPIC30F5015	48
Register Map for dsPIC30F5016	49
External Requests	47
Interrupt Stack Frame	47
Priority	44
Sequence	47
I ² C Master Mode	
Baud Rate Generator	117
Clock Arbitration	118
Multi-Master Communication, Bus Collision and Bus Arbitration	118
Reception	117

Transmission	117	Marking	217
I ² C Module	113	Peripheral Module Disable (PMD) Registers	163
Addresses	115	Pinout Descriptions	
General Call Address Support	117	dsPIC30F5015	11
Interrupts	117	dsPIC30F5016	14
IPMI Support	117	POR. See Power-on Reset.	
Master Operation	117	Port Write/Read Example	62
Master Support	117	Position Measurement Mode	92
Operating Function Description	113	Power-Down Current (IPD)	182
Operation During CPU Sleep and Idle Modes	118	Power-on Reset (POR)	151
Pin Configuration	113	Oscillator Start-up Timer (OST)	151
Programmer's Model	113	Power-up Timer (PWRT)	151
Register Map	119	Power-Saving Modes	161
Registers	113	Idle	162
Slope Control	117	Sleep	161
Software Controlled Clock Stretching (STREN = 1)	116	Power-Saving Modes (Sleep and Idle)	151
Various Modes	113	Program Address Space	25
I ² C 10-bit Slave Mode Operation	115	Construction	26
Reception	116	Data Access from Program Memory Using Program	
Transmission	116	Space Visibility	28
I ² C 7-bit Slave Mode Operation	115	Data Access from Program Memory Using Table Instruc-	
Reception	115	tions	27
Transmission	115	Data Access from, Address Generation	26
M		Memory Map	25
Memory Organization	25	Table Instructions	
Microchip Internet Web Site	229	TBLRDH	27
Modulo Addressing	38	TBLRDL	27
Applicability	40	TBLWTH	27
Operation Example	39	TBLWTL	27
Start and End Address	39	Program Counter	18
W Address Register Selection	39	Program Data Table Access (MSB)	28
Motor Control PWM Module	97	Program Space Visibility	
MPLAB ASM30 Assembler, Linker, Librarian	174	Window into Program Space Operation	29
MPLAB Integrated Development Environment Software	173	Programmable	151
MPLAB PM3 Device Programmer	176	Programmable Digital Noise Filters	93
MPLAB REAL ICE In-Circuit Emulator System	175	Programmer's Model	18
MPLINK Object Linker/MPLIB Object Librarian	174	Protection Against Accidental Writes to OSCCON	157
N		PWM	
NVM		Center-Aligned	101
Register Map	55	Complementary Operation	102
O		Dead-Time Generators	102
Operating Current (IDD)	180	Assignment	103
Oscillator		Ranges	103
Operating Modes (Table)	152	Selection Bits	103
System Overview	151	Duty Cycle Comparison Units	101
Oscillator Configurations	154	Immediate Updates	102
Fail-Safe Clock Monitor	156	Register Buffers	102
Fast RC (FRC)	155	Edge-Aligned	100
Initial Clock Source Selection	154	Fault Pins	105
Low-Power RC (LPRC)	156	Enable Bits	105
LP Oscillator Control	155	Fault States	105
Phase-Locked Loop (PLL)	155	Input Modes	105
Start-up Timer (OST)	155	Priority	105
Oscillator Selection	151	Independent Output	104
Output Compare Module	85	Operation During CPU Idle Mode	106
Interrupts	88	Operation During CPU Sleep Mode	106
Operation During CPU Idle Mode	88	Output and Polarity Control	105
Operation During CPU Sleep Mode	88	Output Pin Control	105
Register Map	89	Output Override	104
Timer2, Timer3 Selection Mode	86	Complementary Output Mode	104
P		Synchronization	104
Packaging		Period	100
Information	217	Single-Pulse Operation	104
		Special Event Trigger	106
		Postscaler	106
		Time Base	99

dsPIC30F5015/5016

Continuous Up/Down Counting Modes	99	Gate Operation	68
Double Update Mode	100	Interrupt	69
Free-Running Mode	99	Operation During Sleep Mode	68
Postscaler	100	Prescaler	68
Prescaler	100	Real-Time Clock	69
Single-Shot Mode	99	Interrupts	69
Update Lockout	106	Oscillator Operation	69
Q		Register Map	70
Quadrature Encoder Interface (QEI)	91	16-bit Asynchronous Counter Mode	67
Interrupts	94	16-bit Synchronous Counter Mode	67
Logic	92	16-bit Timer Mode	67
Operation During CPU Idle Mode	93	Timer2/3 Module	71
Operation During CPU Sleep Mode	93	ADC Event Trigger	74
Register Map	95	Gate Operation	74
Timer Operation During CPU Idle Mode	93	Interrupt	74
Timer Operation During CPU Sleep Mode	93	Operation During Sleep Mode	74
		Register Map	75
R		Timer Prescaler	74
Reader Response	230	16-bit Mode	71
Reset	151, 157	32-bit Synchronous Counter Mode	71
Reset Sequence	45	32-bit Timer Mode	71
Reset Sources	45	Timer4/5 Module	77
Resets		Register Map	79
BOR, Programmable	159	Timing Diagrams	
POR	157	Band Gap Start-up Time	193
POR with Long Crystal Start-up Time	159	Brown-out Reset	184
POR, Operating without FSCM and PWRT	159	CAN Bit	134
Run-Time Self-Programming (RTSP)	51	CAN Module I/O	211
Control Registers	52	Center-Aligned PWM	101
NVMADR	52	CLKOUT and I/O	191
NVMADRU	52	Dead-Time	103
NVMCON	52	Edge-Aligned PWM	101
NVMKEY	52	External Clock	186
Operation	52	Input Capture (CAPx)	197
		I ² C Bus Data (Master Mode)	207
S		I ² C Bus Data (Slave Mode)	209
Simple Capture Event Mode		I ² C Bus Start/Stop Bits (Master Mode)	207
Capture Buffer Operation	82	I ² C Bus Start/Stop Bits (Slave Mode)	209
Capture Prescaler	81	Motor Control PWM Module	199
Hall Sensor Mode	82	Motor Control PWM Module Fault	199
Timer2 and Timer3 Selection Mode	82	OC/PWM Module	198
Simple Output Compare Match Mode	86	Output Compare (OCx)	197
Simple PWM Mode	86	PWM Output	87
Input Pin Fault Protection	86	QEA/QEB Input Characteristics	200
Period	87	QEI Module Index Pulse	201
Software Simulator (MPLAB SIM)	175	Reset, Watchdog Timer, Oscillator Start-up Timer and Power-up Timer	192
Software Stack Pointer, Frame Pointer	18	SPI Master Mode (CKE = 0)	202
CALL Stack Frame	33	SPI Master Mode (CKE = 1)	203
SPI Module	109	SPI Slave Mode (CKE = 0)	204
Framed SPI Support	111	SPI Slave Mode (CKE = 1)	205
Operating Function Description	109	Time-out Sequence on Power-up (MCLR Not Tied to VDD), Case 1	158
Operation During CPU Idle Mode	111	Time-out Sequence on Power-up (MCLR Not Tied to VDD), Case 2	158
Operation During CPU Sleep Mode	111	Time-out Sequence on Power-up (MCLR Tied to VDD) . 158	
SDOx Disable	110	TimerQ (QEI Module) External Clock	196
Slave Select Synchronization	111	Timer1, 2, 3, 4, 5 External Clock	194
SPI1 Register Map	112	10-bit High-Speed A/D Conversion (CHPS = 01, SIMSAM = 0, ASAM = 0, SSRC = 000)	214
SPI2 Register Map	112	10-bit High-Speed A/D Conversion (CHPS = 01, SIMSAM = 0, ASAM = 1, SSRC = 111, SAMC = 00001)	215
Word and Byte Communication	109	Timing Requirements	
STATUS Register	18		
Symbols Used in Opcode Descriptions	166		
System Integration	151		
Register Map	164		
T			
Timer1 Module	67		

A/D Conversion	216	Operation	161
Band Gap Start-up Time	193	WWW Address	229
CAN Module I/O	211	WWW, On-Line Support	7
CLKOUT and I/O	191	Z	
External Clock	187	10-Bit High-Speed Analog-to-Digital (A/D)	
Input Capture	197	Converter Module	139
I ² C Bus Data (Master Mode)	208	16-bit Up/Down Position Counter Mode	92
I ² C Bus Data (Slave Mode)	210	Count Direction Status	92
Motor Control PWM Module	199	Error Checking	92
Output Compare	197	8-Output PWM	
QEI Module External Clock	196	Register Map	107
QEI Module Index Pulse	201		
Quadrature Decoder	200		
Reset, Watchdog Timer, Oscillator Start-up Timer, Power-up Timer and Brown-out Reset	193		
Simple OC/PWM Mode	198		
SPI Master Mode (CKE = 0)	202		
SPI Master Mode (CKE = 1)	203		
SPI Slave Mode (CKE = 0)	204		
SPI Slave Mode (CKE = 1)	206		
Timer1 External Clock	194		
Timer2 and Timer4 External Clock	195		
Timer3 and Timer5 External Clock	195		
Timing Specifications			
PLL Clock	188		
Traps	45		
Hard and Soft	46		
Sources	45		
Vectors	46		
U			
UART			
Address Detect Mode	125		
Auto-Baud Support	126		
Baud Rate Generator	125		
Disabling	123		
Enabling	123		
Loopback Mode	125		
Module Overview	121		
Operation During CPU Sleep and Idle Modes	126		
Receiving Data	124		
In 8-bit or 9-bit Data Mode	124		
Interrupt	124		
Receive Buffer (UxRXB)	124		
Reception Error Handling	124		
Framing Error (FERR Bit)	125		
Idle Status	125		
Parity Error (PERR Bit)	125		
Receive Break	125		
Receive Buffer Overrun Error (OERR Bit)	124		
Setting Up Data, Parity and Stop Bit Selections	123		
Transmitting Data	123		
In 8-bit Data Mode	123		
In 9-bit Data Mode	123		
Interrupt	124		
Transmit Buffer (UxTXB)	123		
UART1 Register Map	127		
Unit ID Locations	151		
Universal Asynchronous Receiver Transmitter Module (UART)	121		
W			
Wake-up from Sleep	151		
Wake-up from Sleep and Idle	47		
Watchdog Timer (WDT)	151, 161		
Enabling and Disabling	161		

dsPIC30F5015/5016

NOTES:

THE MICROCHIP WEB SITE

Microchip provides online support via our WWW site at www.microchip.com. This web site is used as a means to make files and information easily available to customers. Accessible by using your favorite Internet browser, the web site contains the following information:

- **Product Support** – Data sheets and errata, application notes and sample programs, design resources, user's guides and hardware support documents, latest software releases and archived software
- **General Technical Support** – Frequently Asked Questions (FAQs), technical support requests, online discussion groups, Microchip consultant program member listing
- **Business of Microchip** – Product selector and ordering guides, latest Microchip press releases, listing of seminars and events, listings of Microchip sales offices, distributors and factory representatives

CUSTOMER CHANGE NOTIFICATION SERVICE

Microchip's customer notification service helps keep customers current on Microchip products. Subscribers will receive e-mail notification whenever there are changes, updates, revisions or errata related to a specified product family or development tool of interest.

To register, access the Microchip web site at www.microchip.com. Under "Support", click on "Customer Change Notification" and follow the registration instructions.

CUSTOMER SUPPORT

Users of Microchip products can receive assistance through several channels:

- Distributor or Representative
- Local Sales Office
- Field Application Engineer (FAE)
- Technical Support
- Development Systems Information Line

Customers should contact their distributor, representative or field application engineer (FAE) for support. Local sales offices are also available to help customers. A listing of sales offices and locations is included in the back of this document.

Technical support is available through the web site at: <http://support.microchip.com>

dsPIC30F5015/5016

READER RESPONSE

It is our intention to provide you with the best documentation possible to ensure successful use of your Microchip product. If you wish to provide your comments on organization, clarity, subject matter, and ways in which our documentation can better serve you, please FAX your comments to the Technical Publications Manager at (480) 792-4150.

Please list the following information, and use this outline to provide us with your comments about this document.

TO: Technical Publications Manager Total Pages Sent _____

RE: Reader Response

From: Name _____

Company _____

Address _____

City / State / ZIP / Country _____

Telephone: (_____) _____ - _____ FAX: (_____) _____ - _____

Application (optional):

Would you like a reply? Y N

Device: dsPIC30F5015/5016

Literature Number: DS70149E

Questions:

1. What are the best features of this document?

2. How does this document meet your hardware and software development needs?

3. Do you find the organization of this document easy to follow? If not, why?

4. What additions to the document do you think would enhance the structure and subject?

5. What deletions from the document could be made without affecting the overall usefulness?

6. Is there any incorrect or misleading information (what and where)?

7. How would you improve this document?

dsPIC30F5015/5016

PRODUCT IDENTIFICATION SYSTEM

To order or obtain information, e.g., on pricing or delivery, refer to the factory or the listed sales office.

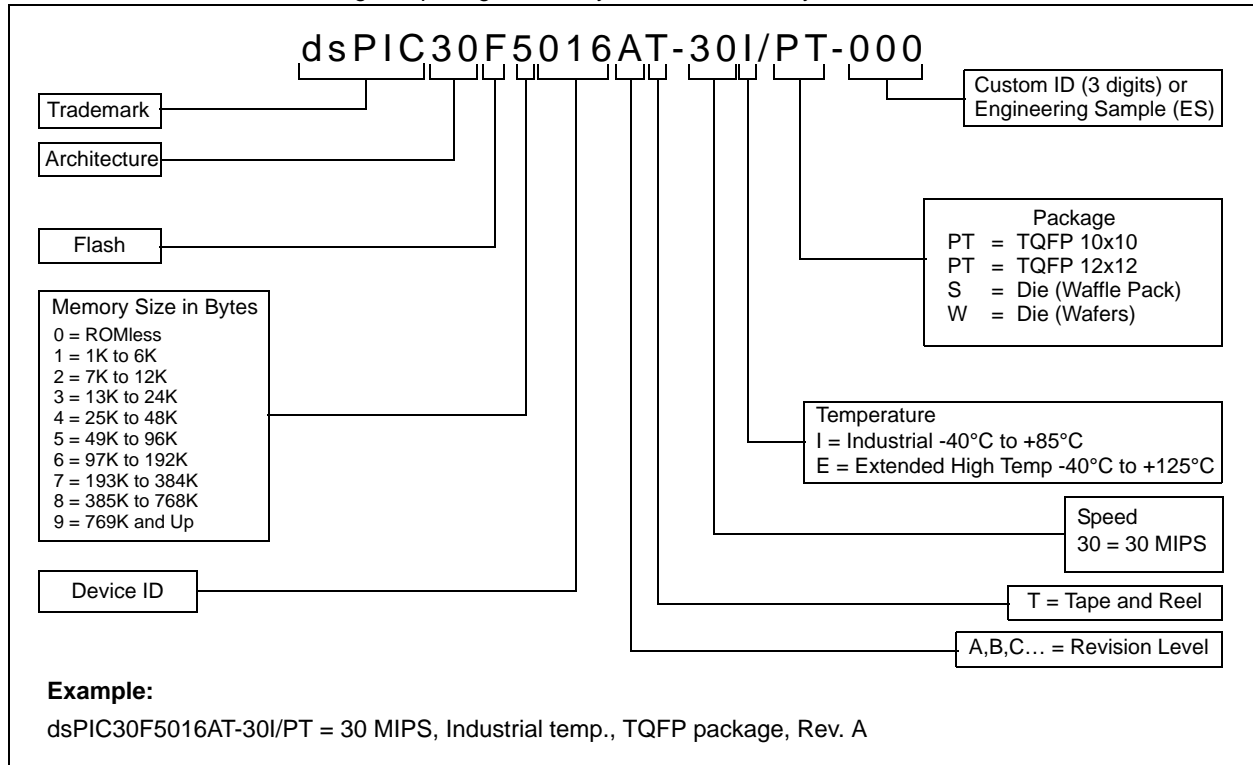



MICROCHIP

Worldwide Sales and Service

AMERICAS

Corporate Office
2355 West Chandler Blvd.
Chandler, AZ 85224-6199
Tel: 480-792-7200
Fax: 480-792-7277
Technical Support:
<http://support.microchip.com>
Web Address:
www.microchip.com

Atlanta
Duluth, GA
Tel: 678-957-9614
Fax: 678-957-1455

Boston
Westborough, MA
Tel: 774-760-0087
Fax: 774-760-0088

Chicago
Itasca, IL
Tel: 630-285-0071
Fax: 630-285-0075

Cleveland
Independence, OH
Tel: 216-447-0464
Fax: 216-447-0643

Dallas
Addison, TX
Tel: 972-818-7423
Fax: 972-818-2924

Detroit
Farmington Hills, MI
Tel: 248-538-2250
Fax: 248-538-2260

Kokomo
Kokomo, IN
Tel: 765-864-8360
Fax: 765-864-8387

Los Angeles
Mission Viejo, CA
Tel: 949-462-9523
Fax: 949-462-9608

Santa Clara
Santa Clara, CA
Tel: 408-961-6444
Fax: 408-961-6445

Toronto
Mississauga, Ontario,
Canada
Tel: 905-673-0699
Fax: 905-673-6509

ASIA/PACIFIC

Asia Pacific Office
Suites 3707-14, 37th Floor
Tower 6, The Gateway
Harbour City, Kowloon
Hong Kong
Tel: 852-2401-1200
Fax: 852-2401-3431

Australia - Sydney
Tel: 61-2-9868-6733
Fax: 61-2-9868-6755

China - Beijing
Tel: 86-10-8528-2100
Fax: 86-10-8528-2104

China - Chengdu
Tel: 86-28-8665-5511
Fax: 86-28-8665-7889

China - Chongqing
Tel: 86-23-8980-9588
Fax: 86-23-8980-9500

China - Hong Kong SAR
Tel: 852-2401-1200
Fax: 852-2401-3431

China - Nanjing
Tel: 86-25-8473-2460
Fax: 86-25-8473-2470

China - Qingdao
Tel: 86-532-8502-7355
Fax: 86-532-8502-7205

China - Shanghai
Tel: 86-21-5407-5533
Fax: 86-21-5407-5066

China - Shenyang
Tel: 86-24-2334-2829
Fax: 86-24-2334-2393

China - Shenzhen
Tel: 86-755-8203-2660
Fax: 86-755-8203-1760

China - Wuhan
Tel: 86-27-5980-5300
Fax: 86-27-5980-5118

China - Xian
Tel: 86-29-8833-7252
Fax: 86-29-8833-7256

China - Xiamen
Tel: 86-592-2388138
Fax: 86-592-2388130

China - Zhuhai
Tel: 86-756-3210040
Fax: 86-756-3210049

ASIA/PACIFIC

India - Bangalore
Tel: 91-80-3090-4444
Fax: 91-80-3090-4123

India - New Delhi
Tel: 91-11-4160-8631
Fax: 91-11-4160-8632

India - Pune
Tel: 91-20-2566-1512
Fax: 91-20-2566-1513

Japan - Yokohama
Tel: 81-45-471- 6166
Fax: 81-45-471-6122

Korea - Daegu
Tel: 82-53-744-4301
Fax: 82-53-744-4302

Korea - Seoul
Tel: 82-2-554-7200
Fax: 82-2-558-5932 or
82-2-558-5934

Malaysia - Kuala Lumpur
Tel: 60-3-6201-9857
Fax: 60-3-6201-9859

Malaysia - Penang
Tel: 60-4-227-8870
Fax: 60-4-227-4068

Philippines - Manila
Tel: 63-2-634-9065
Fax: 63-2-634-9069

Singapore
Tel: 65-6334-8870
Fax: 65-6334-8850

Taiwan - Hsin Chu
Tel: 886-3-6578-300
Fax: 886-3-6578-370

Taiwan - Kaohsiung
Tel: 886-7-213-7830
Fax: 886-7-330-9305

Taiwan - Taipei
Tel: 886-2-2500-6610
Fax: 886-2-2508-0102

Thailand - Bangkok
Tel: 66-2-694-1351
Fax: 66-2-694-1350

EUROPE

Austria - Wels
Tel: 43-7242-2244-39
Fax: 43-7242-2244-393

Denmark - Copenhagen
Tel: 45-4450-2828
Fax: 45-4485-2829

France - Paris
Tel: 33-1-69-53-63-20
Fax: 33-1-69-30-90-79

Germany - Munich
Tel: 49-89-627-144-0
Fax: 49-89-627-144-44

Italy - Milan
Tel: 39-0331-742611
Fax: 39-0331-466781

Netherlands - Drunen
Tel: 31-416-690399
Fax: 31-416-690340

Spain - Madrid
Tel: 34-91-708-08-90
Fax: 34-91-708-08-91

UK - Wokingham
Tel: 44-118-921-5869
Fax: 44-118-921-5820

08/04/10

Mouser Electronics

Authorized Distributor

Click to View Pricing, Inventory, Delivery & Lifecycle Information:

Microchip:

[DSPIC30F5015-20E/PT](#) [DSPIC30F5015-20I/PT](#) [DSPIC30F5015-30I/PT](#) [DSPIC30F5015T-20E/PT](#) [DSPIC30F5015T-30I/PT](#) [DSPIC30F5016-20E/PT](#) [DSPIC30F5016-30I/PT](#) [DSPIC30F5016T-20E/PT](#) [DSPIC30F5016T-30I/PT](#)



Компания «ЭлектроПласт» предлагает заключение долгосрочных отношений при поставках импортных электронных компонентов на взаимовыгодных условиях!

Наши преимущества:

- Оперативные поставки широкого спектра электронных компонентов отечественного и импортного производства напрямую от производителей и с крупнейших мировых складов;
- Поставка более 17-ти миллионов наименований электронных компонентов;
- Поставка сложных, дефицитных, либо снятых с производства позиций;
- Оперативные сроки поставки под заказ (от 5 рабочих дней);
- Экспресс доставка в любую точку России;
- Техническая поддержка проекта, помощь в подборе аналогов, поставка прототипов;
- Система менеджмента качества сертифицирована по Международному стандарту ISO 9001;
- Лицензия ФСБ на осуществление работ с использованием сведений, составляющих государственную тайну;
- Поставка специализированных компонентов (Xilinx, Altera, Analog Devices, Intersil, Interpoint, Microsemi, Aeroflex, Peregrine, Syfer, Eurofarad, Texas Instrument, Miteq, Cobham, E2V, MA-COM, Hittite, Mini-Circuits, General Dynamics и др.);

Помимо этого, одним из направлений компании «ЭлектроПласт» является направление «Источники питания». Мы предлагаем Вам помощь Конструкторского отдела:

- Подбор оптимального решения, техническое обоснование при выборе компонента;
- Подбор аналогов;
- Консультации по применению компонента;
- Поставка образцов и прототипов;
- Техническая поддержка проекта;
- Защита от снятия компонента с производства.



Как с нами связаться

Телефон: 8 (812) 309 58 32 (многоканальный)

Факс: 8 (812) 320-02-42

Электронная почта: org@eplast1.ru

Адрес: 198099, г. Санкт-Петербург, ул. Калинина, дом 2, корпус 4, литера А.