

GOT5840T-845 NEW

8.4" SVGA TFT Fanless Touch Panel Computer with Intel® Celeron® Processor N3060

Features

- 8.4" SVGA TFT LCD display with LED backlight
- Fanless cooling system with Intel® Celeron® processor N3060 (up to 2.48 GHz)
- Ultra slim and super light design
- WLAN module and internal antenna
- 2 PCI Express Mini Card slots
- 2 GbE LAN, 2 USB and 2 COM
- Supports optional panel mount/wall mount/VESA arm/desktop stand
- Plastic and IP65-rated front bezel

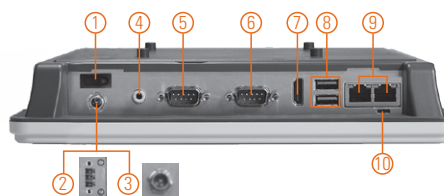

- | | |
|------------------------------------|------------------------------|
| 1. Power switch (ATX) | 6. COM 2 (RS-232) |
| 2. Power input connector (screw) | 7. HDMI |
| 3. Power input connector (phoenix) | 8. USB 3.0 x 2 |
| 4. Audio (Line-out) | 9. Ethernet (RJ-45) |
| 5. COM 1 (RS-232/422485) | 10. AX/ATX selectable switch |



Introduction

The GOT5840T-845 is an 8.4" Intel® Celeron®-based fanless touch panel computer. In response to market demand, this panel computer is a cost effective solution. It adopts a modern, super sleek and fanless design and is equipped with a 8.4" TFT LCD as well as Intel® Celeron® processor N3060 (Braswell). For wireless network connection, the GOT5840T-845 offers 2 PCI Express Mini Card slots. By just plugging in the mini card WLAN card, customers can have instant access to wireless LAN/GPRS/GSM/4G environments. Besides, it provides two types of power input. One is DC power input with terminal block connector, and another is AC power adapter with screw type connector.

Super Slim & Ultra Lightweight Design

The GOT5840T-845 is a super slim touch panel computer for space-limited environment with its thickness of 45 mm and weight of 1.3 kg only, which make it installed everywhere.

Built-in Internal WLAN Antenna

The GOT5840T-845 provides 2 PCI Express Mini Card slots and a built-in WLAN antenna for wireless network connections. By simply plugging in the wireless LAN card, customers can use the GOT5840T-845 in a wireless LAN/GPRS/GSM/4G environments.

Aluminum Back Chassis with Excellent Thermal Solution

With Axiomtek's patent for plastic plus aluminum mechanism design, the GOT5840T-845 can dissipate the heat easily and keep the system operation stable.

Specifications

Front Bezel	IP65, NEMA 4 rugged protection, plastic front bezel	
LCD Panel	Display Type	8.4" SVGA TFT LCD with LED backlight
	Brightness (cd/m ²)	350 nits
	Resolution	800 x 600
	Viewing Angel (H/V)	160°/140°
Main System	CPU	Intel® Celeron® processor N3060 2 cores (up to 2.48 GHz)
	System Memory	1 x 204-pin DDR3L-1600 MHz SO-DIMM, up to 8GB
	BIOS	AMI UEFI BIOS
	Storage	1 x mSATA
	Watchdog Timer	255 levels, 0 – 255 sec.
	Onboard Graphics	Integrated in Intel® GFX

Specifications

I/O Connector	1 x RS-232 (COM 2) 1 x RS-232/422/485 (default RS-232, COM 1) 1 x HDMI 1 x Switch for power on/off 1 x AT/ATX mode selection switch 2 x USB 3.0 1 x Audio (Line-out) 2 x 10/100/1000 Mbps Ethernet (Intel® i211AT)
TPM	N/A
Expansion Interface	1 x full-size PCI Express Mini Card slot with mSATA 1 x full-size PCI Express Mini Card slot with SIM
Touchscreen	Resistive type
Power Input	1. AC version: 100 ~ 240 V AC-DC, 60W power adapter or 2. DC version: 9 ~ 36 VDC with over current protection fuse
Power Consumption	25 W
Dimensions	250.7 mm (9.87") (W) x 45.8 mm (1.80") (D) x 204.7 mm (8.06") (H)
Packing Dimensions	380 mm (14.96") (W) x 100 mm (3.94") (D) x 280 mm (11.02") (H)
Weight (net/gross)	1.3 kg (2.87 lb)/ 2.25 kg (4.96 lb)
Environment	Operating temperature: 0° ~ +50°C (+32°F ~ +122°F) (with W.T. DRAM/HDD in airflow condition) 0° ~ +45°C (+32°F ~ +113°F) (with W.T. DRAM) Relative humidity: 20% ~ 90% @ +40°C; non-condensing Operation vibration: 2G, 5-500Hz, random for mSATA
Certificate	CE

Packing List

- 1 x GOT5840T-845
- 1 x Driver CD
- 1 x Adapter (GOT5840T-845-J)
- 1 x Power cord (GOT5840T-845-J)
- 1 x Phoenix Connector (GOT5840T-845 24V DC)

Dimensions

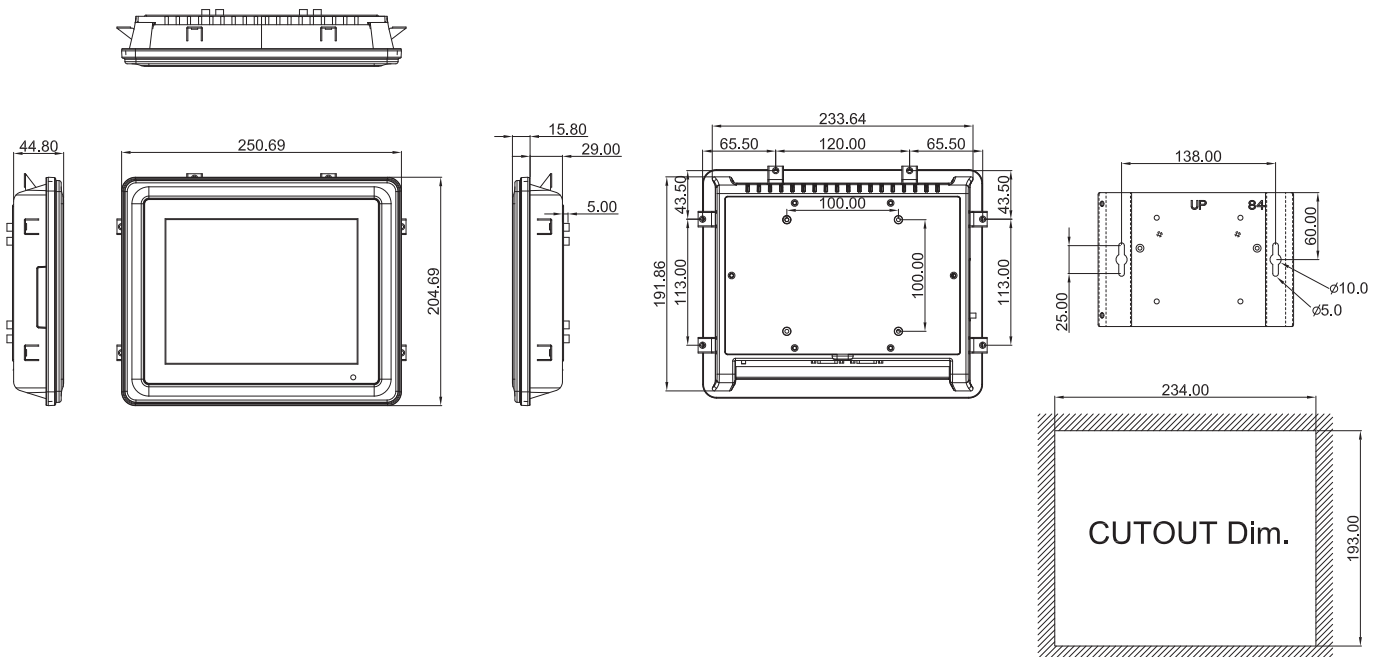

Ordering Information

GOT5840T-845-J	8.4" SVGA fanless touch panel computer with Intel® Celeron® processor N3060, 5-wire resistive touch screen, AC-DC 60W power adapter (screw type connector) and EMI class A
GOT5840T-845-DC	8.4" SVGA fanless touch panel computer with Intel® Celeron® processor N3060, 5-wire resistive touch screen and 9 ~ 36 VDC power input (terminal block connector)

Optional

Wi-Fi + Bluetooth kit	
881258400A0E	Panel mount kit
881258401A0E	Wall mount kit
E226171106	Stand kit
881251203A0E	RFID kit

* Specification and certifications are based on requirements and may vary.

Optional EOS Installation

WES 7
WE8S (64-bit)
Windows® 10 IoT Enterprise (64bit)

Optional OS Installation

Windows® 7
Windows® 8.1 (64-bit)
Windows® 10





Компания «ЭлектроПласт» предлагает заключение долгосрочных отношений при поставках импортных электронных компонентов на взаимовыгодных условиях!

Наши преимущества:

- Оперативные поставки широкого спектра электронных компонентов отечественного и импортного производства напрямую от производителей и с крупнейших мировых складов;
- Поставка более 17-ти миллионов наименований электронных компонентов;
- Поставка сложных, дефицитных, либо снятых с производства позиций;
- Оперативные сроки поставки под заказ (от 5 рабочих дней);
- Экспресс доставка в любую точку России;
- Техническая поддержка проекта, помощь в подборе аналогов, поставка прототипов;
- Система менеджмента качества сертифицирована по Международному стандарту ISO 9001;
- Лицензия ФСБ на осуществление работ с использованием сведений, составляющих государственную тайну;
- Поставка специализированных компонентов (Xilinx, Altera, Analog Devices, Intersil, Interpoint, Microsemi, Aeroflex, Peregrine, Syfer, Eurofarad, Texas Instrument, Miteq, Cobham, E2V, MA-COM, Hittite, Mini-Circuits, General Dynamics и др.);

Помимо этого, одним из направлений компании «ЭлектроПласт» является направление «Источники питания». Мы предлагаем Вам помощь Конструкторского отдела:

- Подбор оптимального решения, техническое обоснование при выборе компонента;
- Подбор аналогов;
- Консультации по применению компонента;
- Поставка образцов и прототипов;
- Техническая поддержка проекта;
- Защита от снятия компонента с производства.



Как с нами связаться

Телефон: 8 (812) 309 58 32 (многоканальный)

Факс: 8 (812) 320-02-42

Электронная почта: org@eplast1.ru

Адрес: 198099, г. Санкт-Петербург, ул. Калинина, дом 2, корпус 4, литера А.