



# SANYO Semiconductors DATA SHEET

## LB1938FA — Monolithic Digital IC 1ch, Low-saturation Forward/Reverse Motor Driver

### Overview

The LB1938FA is an H-bridge motor driver that supports low-voltage drive and features low-saturation outputs in an ultraminiature slim package. The LB1938FA provides forward, reverse, brake, and standby modes controlled by two input signals, and is an optimal DC motor driver for notebook personal computers, digital cameras, cell phones, and other portable equipment.

### Features

- Ultraminiature Micro8 package
- The low saturation voltage means that the voltage applied to the motor is higher and IC heat generation is reduced. This allows this IC to be used in environments with higher ambient operating temperatures.  
Output saturation voltage (high side + low side):  $V_{OSat} = 0.15V$  typical ( $I_O = 100mA$ )
- The wide usable voltage range and the low standby mode current drain of  $0.1 \mu A$  make this IC optimal for battery operated equipment.
- There are no constraints on the relationship between the input signal voltage and the supply voltage. For example, this IC can be use at  $V_{CC} = 3V$  and  $V_{IN} = 5V$ .
- Thermal protection circuit limits the drive current and prevents the IC from causing a fire or being destroyed if the IC chip temperature reaches or exceeds  $180^{\circ}C$  due to large currents flowing when the outputs are shorted due to, for example, motor layer shorting or other phenomena.

### Specifications

#### Absolute Maximum Ratings at $T_a = 25^{\circ}C$

Parameter	Symbol	Conditions	Ratings	Unit
Supply voltage	$V_{CC}$ max		10.5	V
Output current	$I_{OUT}$ max		800	mA
Output voltage	$V_{OUT}$ max		$V_{CC} + V_{SF}$	V
Input applied voltage	$V_{IH}$ max		10	V

Continued on next page.

- Any and all SANYO Semiconductor Co.,Ltd. products described or contained herein are, with regard to "standard application", intended for the use as general electronics equipment. The products mentioned herein shall not be intended for use for any "special application" (medical equipment whose purpose is to sustain life, aerospace instrument, nuclear control device, burning appliances, transportation machine, traffic signal system, safety equipment etc.) that shall require extremely high level of reliability and can directly threaten human lives in case of failure or malfunction of the product or may cause harm to human bodies, nor shall they grant any guarantee thereof. If you should intend to use our products for new introduction or other application different from current conditions on the usage of automotive device, communication device, office equipment, industrial equipment etc. , please consult with us about usage condition (temperature, operation time etc.) prior to the intended use. If there is no consultation or inquiry before the intended use, our customer shall be solely responsible for the use.
- Specifications of any and all SANYO Semiconductor Co.,Ltd. products described or contained herein stipulate the performance, characteristics, and functions of the described products in the independent state, and are not guarantees of the performance, characteristics, and functions of the described products as mounted in the customer's products or equipment. To verify symptoms and states that cannot be evaluated in an independent device, the customer should always evaluate and test devices mounted in the customer's products or equipment.

# LB1938FA

Continued from preceding page.

Parameter	Symbol	Conditions	Ratings	Unit
Allowable power dissipation	Pd max	Mounted on a specified board *	400	mW
Operating temperature range	Topr		-30 to +85	°C
Storage temperature range	Tstg		-55 to +150	°C

Note \*: Mounted on a specified board: 114.3mm×76.1mm×1.5mm, glass epoxy resin, wiring density 20%

Caution 1) Absolute maximum ratings represent the value which cannot be exceeded for any length of time.

Caution 2) Even when the device is used within the range of absolute maximum ratings, as a result of continuous usage under high temperature, high current, high voltage, or drastic temperature change, the reliability of the IC may be degraded. Please contact us for the further details.

## Allowable Operating Range at Ta = 25°C

Parameter	Symbol	Conditions	Ratings	Unit
Supply voltage	V <sub>CC</sub>		2.2 to 10	V
Input high-level voltage	V <sub>IH</sub>		2.0 to 9.5	V
Input low-level voltage	V <sub>IL</sub>		-0.3 to +0.3	V

## Electrical Characteristics at Ta = 25°C, V<sub>CC</sub> = 3V

Parameter	Symbol	Conditions	Ratings			Unit
			min	typ	max	
Circuit current	I <sub>CC1</sub>	Standby		0.1	5	μA
	I <sub>CC2</sub>	Forward/reverse drive		14	19	mA
	I <sub>CC3</sub>	Brake		20	29	mA
Output saturation voltage	V <sub>OSat1</sub>	Upper+lower I <sub>O</sub> = 100mA for forward/reverse rotation		0.15	0.2	V
	V <sub>OSat2</sub>	Upper+lower I <sub>O</sub> = 300mA for forward/reverse rotation		0.35	0.5	V
	V <sub>OSat3</sub>	Upper I <sub>O</sub> = 100mA for braking		0.1	0.15	V
Spark killer diode forward voltage	V <sub>SF</sub>	I <sub>O</sub> = 300mA		0.9	1.7	V
Spark killer diode inverse current	I <sub>RS</sub>	V <sub>OUT</sub> = 10V		0.1	5	μA
Input current	I <sub>IN</sub>	V <sub>IN</sub> = 5V		75	98	μA
Thermal protection operating temperature	TSD	Design target value *		180		°C

Note \*: Design target value: Measurement with a single unit not made.

## Package Dimensions

unit : mm (typ)

3427

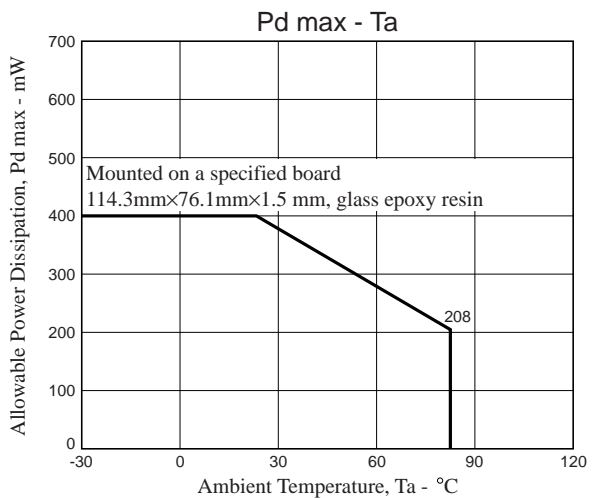
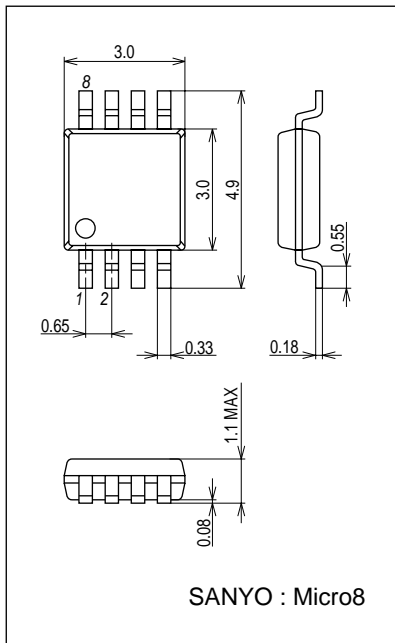

# LB1938FA

## Pin Assignment

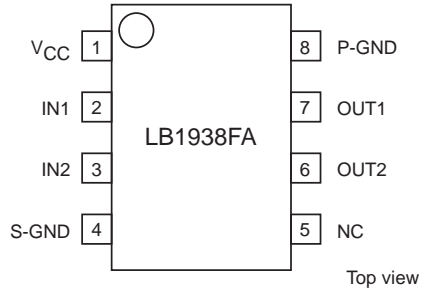

S-GND: GND for the control system

P-GND: GND for the power system

## Truth Table

IN1	IN2	OUT1	OUT2	Mode
L	L	OFF	OFF	Standby
H	L	H	L	Forward rotation
L	H	L	H	Reverse rotation
H	H	H	H	Brake

## Sample Application Circuit

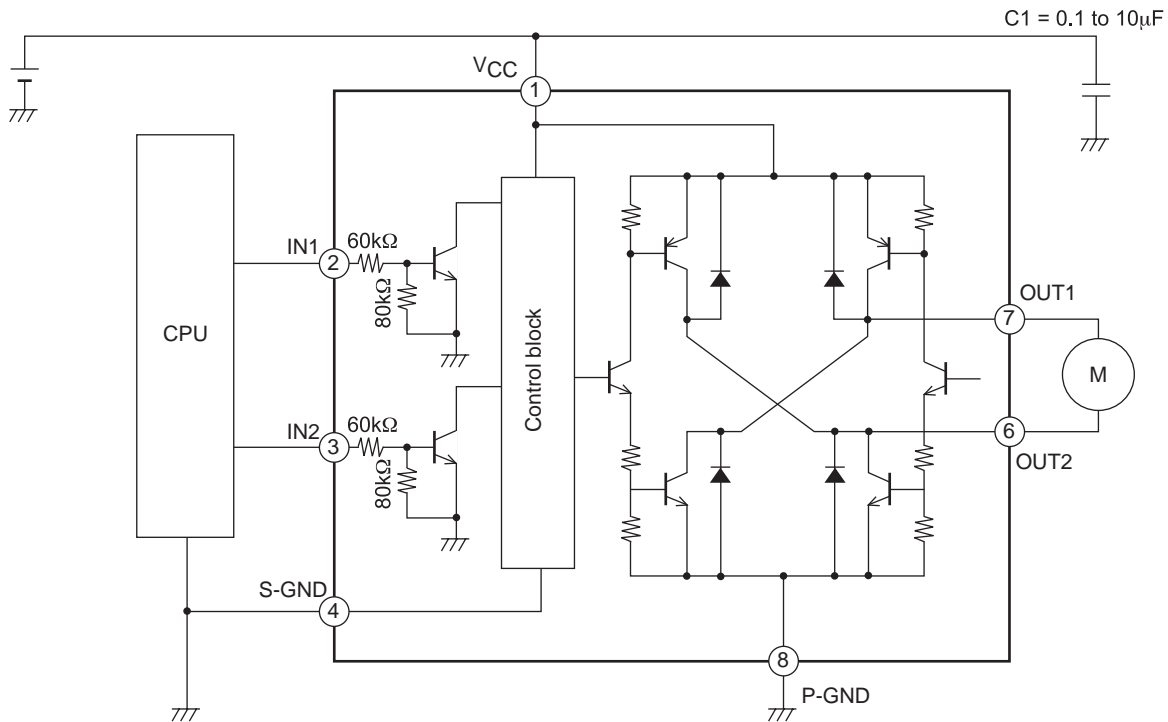

## Cautions:

- VCC and GND lines suffer substantial fluctuation in the current quantity, causing a problem of line oscillation in certain cases. In this case, take following points into account:
  - (1) Use a thick and short wiring to reduce the wiring inductance.
  - (2) Insert a capacitor with satisfactory frequency characteristics near IC.
  - (3) Connect S-GND to the control system GND on the CPU side and P-GND to the power system GND.

# LB1938FA

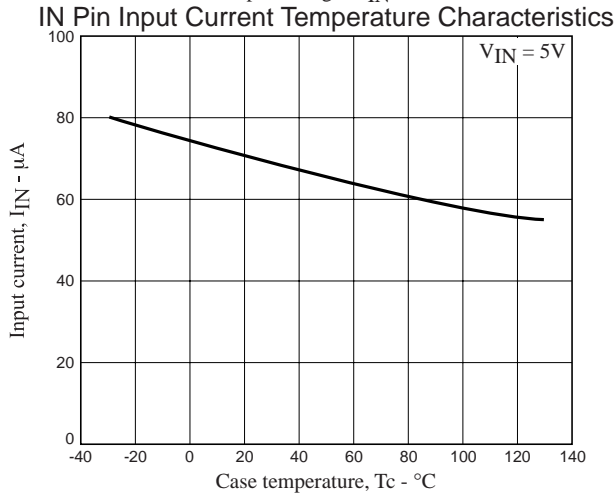
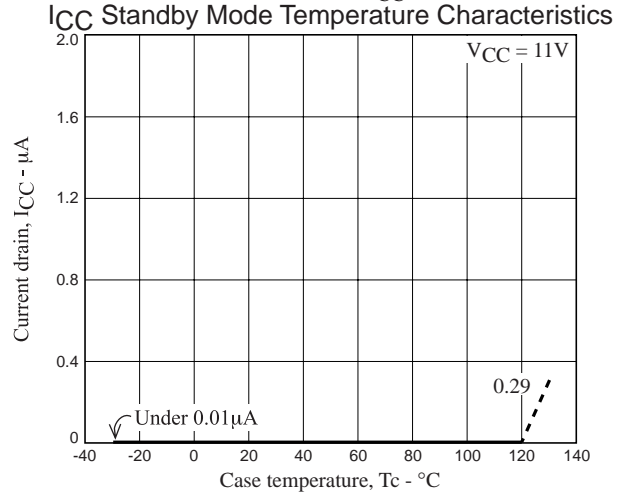
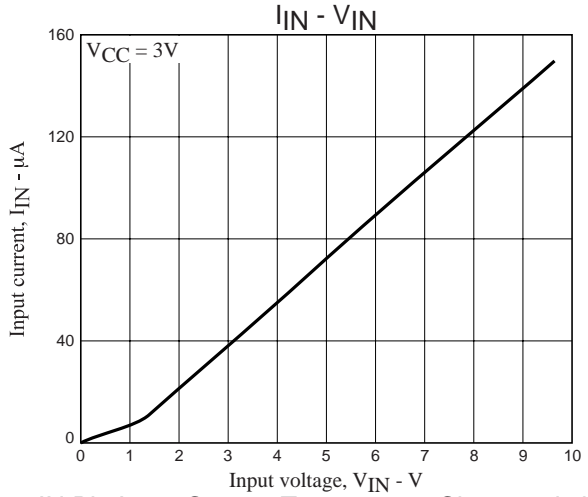
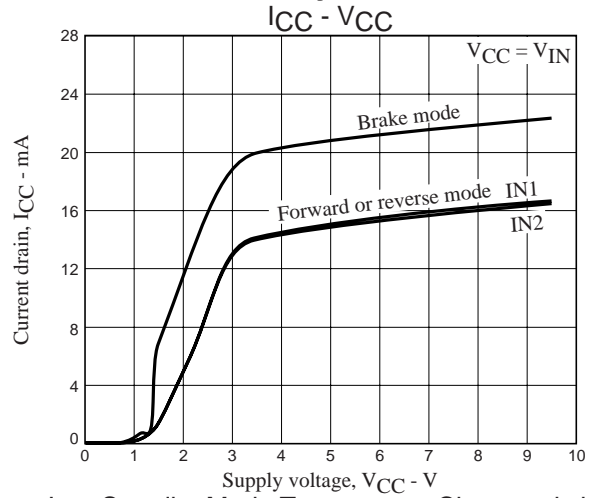
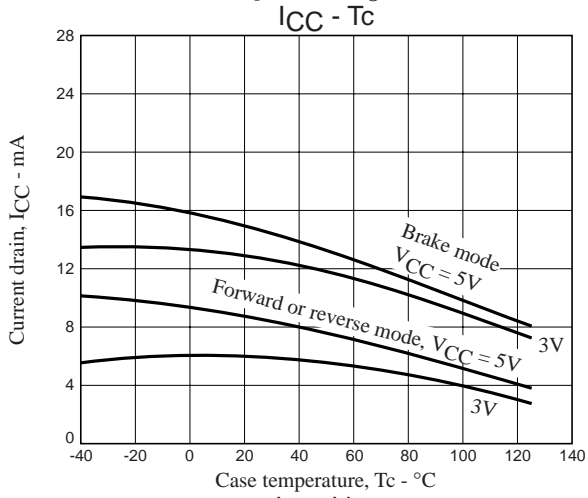
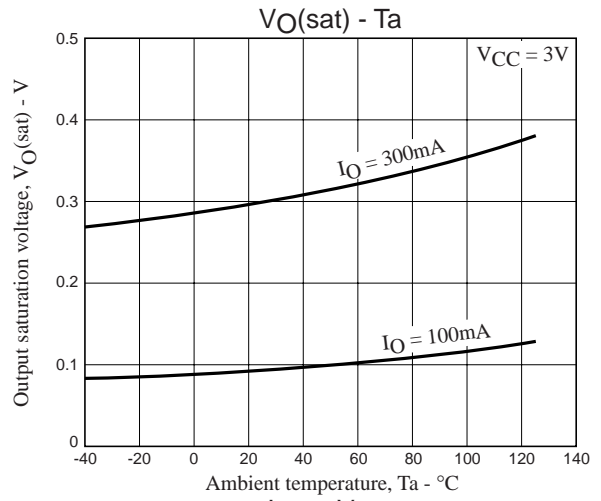
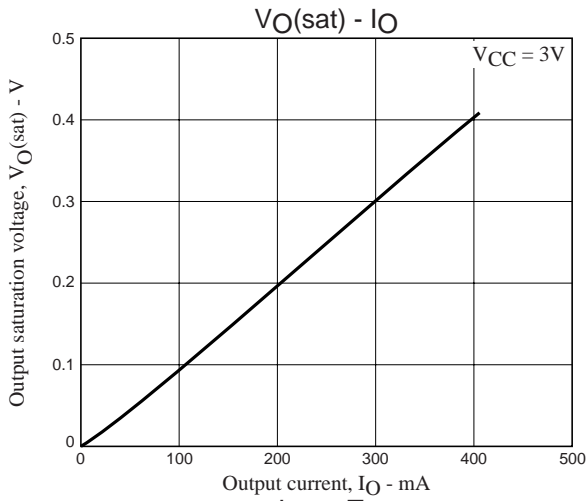

- SANYO Semiconductor Co.,Ltd. assumes no responsibility for equipment failures that result from using products at values that exceed, even momentarily, rated values (such as maximum ratings, operating condition ranges, or other parameters) listed in products specifications of any and all SANYO Semiconductor Co.,Ltd. products described or contained herein.
- SANYO Semiconductor Co.,Ltd. strives to supply high-quality high-reliability products, however, any and all semiconductor products fail or malfunction with some probability. It is possible that these probabilistic failures or malfunction could give rise to accidents or events that could endanger human lives, trouble that could give rise to smoke or fire, or accidents that could cause damage to other property. When designing equipment, adopt safety measures so that these kinds of accidents or events cannot occur. Such measures include but are not limited to protective circuits and error prevention circuits for safe design, redundant design, and structural design.
- In the event that any or all SANYO Semiconductor Co.,Ltd. products described or contained herein are controlled under any of applicable local export control laws and regulations, such products may require the export license from the authorities concerned in accordance with the above law.
- No part of this publication may be reproduced or transmitted in any form or by any means, electronic or mechanical, including photocopying and recording, or any information storage or retrieval system, or otherwise, without the prior written consent of SANYO Semiconductor Co.,Ltd.
- Any and all information described or contained herein are subject to change without notice due to product/technology improvement, etc. When designing equipment, refer to the "Delivery Specification" for the SANYO Semiconductor Co.,Ltd. product that you intend to use.
- Upon using the technical information or products described herein, neither warranty nor license shall be granted with regard to intellectual property rights or any other rights of SANYO Semiconductor Co.,Ltd. or any third party. SANYO Semiconductor Co.,Ltd. shall not be liable for any claim or suits with regard to a third party's intellectual property rights which has resulted from the use of the technical information and products mentioned above.

This catalog provides information as of April, 2012. Specifications and information herein are subject to change without notice.



Компания «ЭлектроПласт» предлагает заключение долгосрочных отношений при поставках импортных электронных компонентов на взаимовыгодных условиях!

Наши преимущества:

- Оперативные поставки широкого спектра электронных компонентов отечественного и импортного производства напрямую от производителей и с крупнейших мировых складов;
- Поставка более 17-ти миллионов наименований электронных компонентов;
- Поставка сложных, дефицитных, либо снятых с производства позиций;
- Оперативные сроки поставки под заказ (от 5 рабочих дней);
- Экспресс доставка в любую точку России;
- Техническая поддержка проекта, помощь в подборе аналогов, поставка прототипов;
- Система менеджмента качества сертифицирована по Международному стандарту ISO 9001;
- Лицензия ФСБ на осуществление работ с использованием сведений, составляющих государственную тайну;
- Поставка специализированных компонентов (Xilinx, Altera, Analog Devices, Intersil, Interpoint, Microsemi, Aeroflex, Peregrine, Syfer, Eurofarad, Texas Instrument, Miteq, Cobham, E2V, MA-COM, Hittite, Mini-Circuits, General Dynamics и др.);

Помимо этого, одним из направлений компании «ЭлектроПласт» является направление «Источники питания». Мы предлагаем Вам помощь Конструкторского отдела:

- Подбор оптимального решения, техническое обоснование при выборе компонента;
- Подбор аналогов;
- Консультации по применению компонента;
- Поставка образцов и прототипов;
- Техническая поддержка проекта;
- Защита от снятия компонента с производства.



#### Как с нами связаться

**Телефон:** 8 (812) 309 58 32 (многоканальный)

**Факс:** 8 (812) 320-02-42

**Электронная почта:** [org@eplast1.ru](mailto:org@eplast1.ru)

**Адрес:** 198099, г. Санкт-Петербург, ул. Калинина, дом 2, корпус 4, литера А.