

MEC CITEC

**POTENTIOMETERS
INDUCTORS, SMDs
SWITCHES, NETWORKS
ENCODERS
POWER COMPONENTS**

Economy Trimmers **TYPE 3140 SERIES**



A range of tiny single turn trimmers suited to reflow soldering and attractively priced for volume application. Alternative layouts in two and three terminal versions and low profile models (2.2mm) make this a very versatile product. All product is supplied on 12mm tape and reeled on 178mm diameter reels.

MEC CITEC KEY FEATURES

- STABLE CERMET ELEMENT
 - 0.15 W POWER RATING
 - PACKED IN 12mm STANDARD TAPE
 - ATTRACTIVELY PRICED
 - SUITED TO AUTOMATIC PLACEMENT
 - RANGE OF TERMINAL LAYOUTS
 - TEMP RANGE -25°C TO +85°C
 - GOOD VACUUM PICK UP ON HEAD
-

SPECIFICATION

ELECTRICAL

Resistance Range:	100R to 1M
Resistance Tolerance:	± 25%
Power Rating:	0.15W @ 70°C derating to zero at 85°C
Max. Input Voltage:	50 vdc or ac RMS max
Max. Wiper Current:	50mA
Electrical Angle, Nominal:	270° ± 10°
End Resistance, Max:	5%
Contact Resistance Variation:	5% max
Operating Temperature:	-25°C to + 85°C
Temp. Coefficient, of Resistance:	± 250 ppm/°C
Insulation Resistance, Min:	100 M Ω (DC 250V)

DERATING CURVE

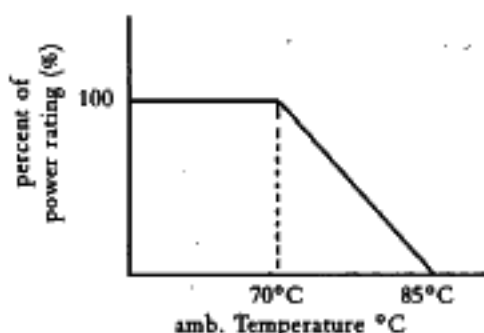

When the ambient temperature exceeds 70°C, reduce the rated power and current in accordance with the derating curve given.

MECHANICAL

Mechanical Angle:	Continuous
Operating Torque, Max:	2.0-24.5 mNm
Solder Strength Min:	300 gF cm (3 directions)

ENVIRONMENTAL

Humidity Exposure:	Res. Change : ± 3%
High Temperature Exposure:	Res. Change : ± 3%
Humidity Load Life:	Res. Change : ± 3%
Load Life:	Res. Change : ± 3%
Temperature Cycle:	Res. Change : ± 3%
Effect of Soldering:	Res. Change : ± 10% (10 cycle)

ALTERNATIVE STYLES

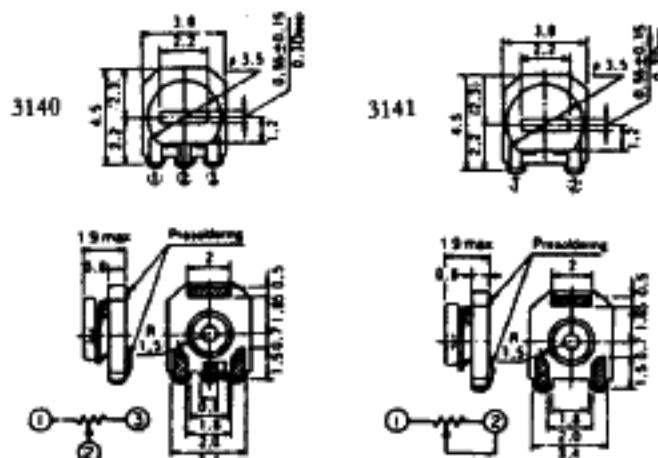

DIMENSIONS

All dimensions are nominal and in 'mm' unless otherwise stated. Do not scale.

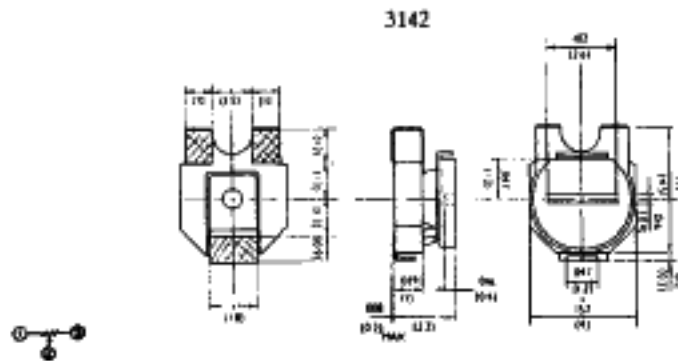

PACKAGING (TAPE)

To meet EIA 481
IEC 286 PT3

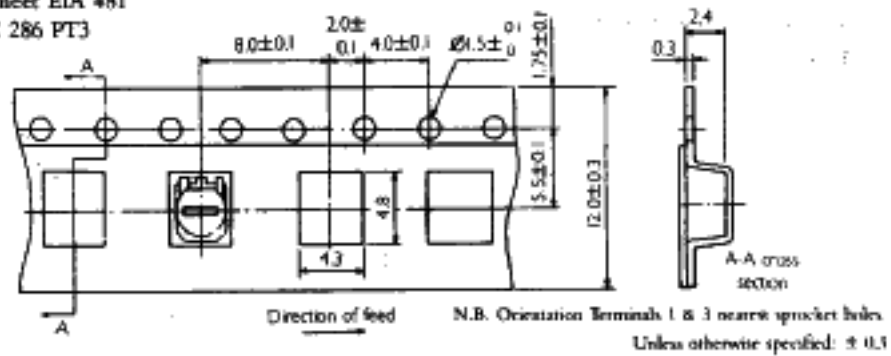

PACKAGING (REEL)

Reel Qty
800 pcs

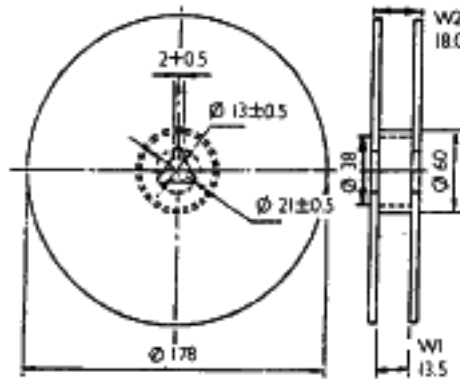

SUBSTRATE LAYOUT

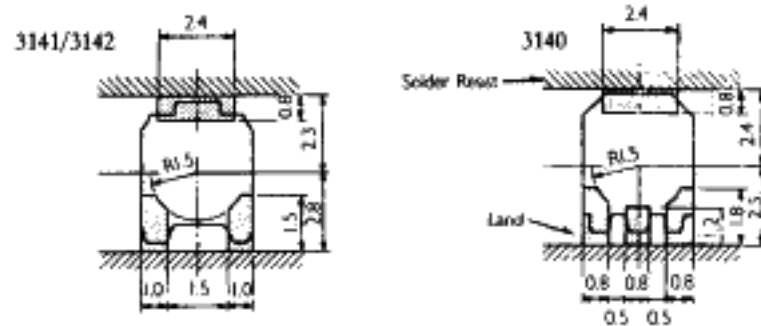

HOW TO ORDER

COMMON PART	ORIENTATION	RESISTANCE VALUE	TOLERANCE
3140 - 3 Terminals in line 3141 - 2 Terminals in line 3142 - 3 Terminals offset	X = Terminals 1 and 3 away from sprocket holes W = Terminals 1 and 3 towards sprocket holes	The first digits are significant figures of resistance value and the third one denotes the number of zeroes following. Example 1 k : 102 5 k : 502 100 k : 104	P = ±25%

APPLICATION NOTES

SOLDERING CONDITIONS

If soldering is repeated, please note that the allowance time is the accumulated time.
Solder : Co-crystalized solder
Flux : Rosin Flux

REFLOW SOLDERING- NO PREHEAT

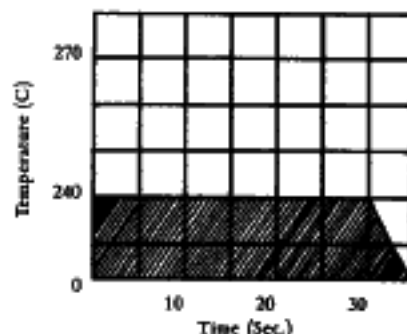

REFLOW SOLDERING RECOMMENDED

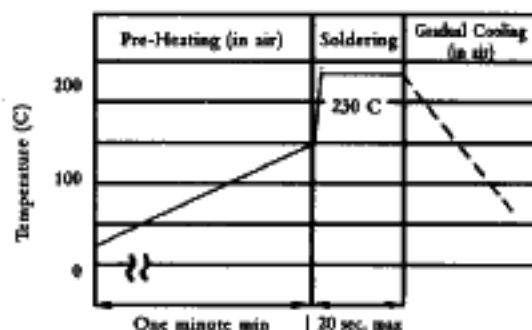

SOLDERING WITH IRON

The following conditions must be strictly obeyed when using a soldering iron.
Soldering Iron : 20W maximum
Tip temperature : 280°C maximum
Soldering time : 5 seconds maximum

CLEANING CONDITIONS

After soldering, use cleaning solvents such as chlorosen or dyefreon.

CAUTION ON SOLDERING

The following conditions must be strictly obeyed when using a soldering iron for rework:
Soldering iron : 20W maximum
Trip temperature : 280°C maximum (To be used only once)
Soldering time : 3 seconds maximum
Be careful not to cause excessive force to be applied to the potentiometer after mounting.
Reduce effects of solder temperature and time as much as possible by giving maximum allowable pre-heating.

STORAGE

To prevent damage to the electrode, be sure to observe the following cautions for storage.
• Store in 40°C maximum ambient temperature, and 70% maximum ambient RH.
• For maximum possible shelf life do not disturb polythene sleeve until you are ready to use potentiometers.
• Store where there are no harmful gasses containing sulphur or chlorine.

All inquires should be directed to:

Piher International Corp.
903 Feehanville Drive.
Mt Prospect, IL 60056



Компания «ЭлектроПласт» предлагает заключение долгосрочных отношений при поставках импортных электронных компонентов на взаимовыгодных условиях!

Наши преимущества:

- Оперативные поставки широкого спектра электронных компонентов отечественного и импортного производства напрямую от производителей и с крупнейших мировых складов;
- Поставка более 17-ти миллионов наименований электронных компонентов;
- Поставка сложных, дефицитных, либо снятых с производства позиций;
- Оперативные сроки поставки под заказ (от 5 рабочих дней);
- Экспресс доставка в любую точку России;
- Техническая поддержка проекта, помощь в подборе аналогов, поставка прототипов;
- Система менеджмента качества сертифицирована по Международному стандарту ISO 9001;
- Лицензия ФСБ на осуществление работ с использованием сведений, составляющих государственную тайну;
- Поставка специализированных компонентов (Xilinx, Altera, Analog Devices, Intersil, Interpoint, Microsemi, Aeroflex, Peregrine, Syfer, Eurofarad, Texas Instrument, Miteq, Cobham, E2V, MA-COM, Hittite, Mini-Circuits, General Dynamics и др.);

Помимо этого, одним из направлений компании «ЭлектроПласт» является направление «Источники питания». Мы предлагаем Вам помощь Конструкторского отдела:

- Подбор оптимального решения, техническое обоснование при выборе компонента;
- Подбор аналогов;
- Консультации по применению компонента;
- Поставка образцов и прототипов;
- Техническая поддержка проекта;
- Защита от снятия компонента с производства.



Как с нами связаться

Телефон: 8 (812) 309 58 32 (многоканальный)

Факс: 8 (812) 320-02-42

Электронная почта: org@eplast1.ru

Адрес: 198099, г. Санкт-Петербург, ул. Калинина, дом 2, корпус 4, литера А.