

SIGN	DATE	DESCRIPTION	APPROVER
△	12/13'12	Change the screw plating specification	Guoxue

THIS IS CAD DRAWING, DO NOT REVISE MANUALLY!!!

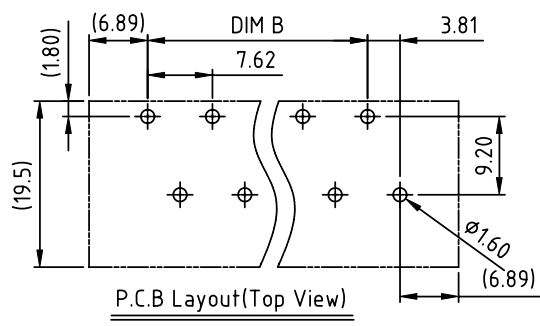
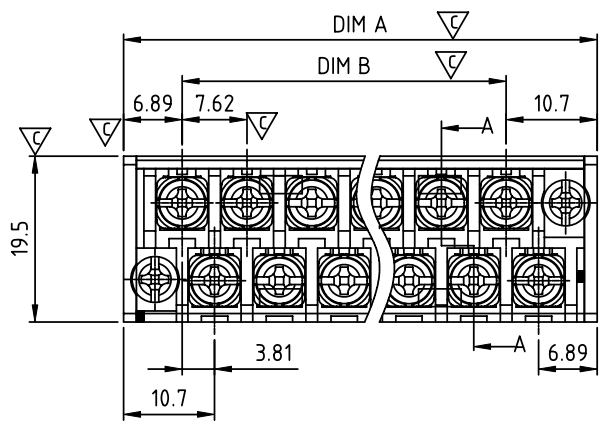

MATERIALS ELECTRICAL
 RATED VOLTAGE & CURRENT: 300 V, 15 A
 WITHSTAND VOLTAGE: AC 2000 V/Min
 INSULATION RESISTANCE: 1000 MΩ OR MORE AT DC 500 V
 OPERATING TEMPERATURE RANG: -40 °C ~ +115 °C
 SOLDEING TEMPERATURE: 250°C±10°C/5 Sec
 SCREW TORQUE VALUE: 7Lb-In
 WIRE RANGE: 22 - 12 AWG
 Safety Approval: US
 Critical dimension:

NO:	Name	Material/ standards	Number
①	Molded Parts:	PBT, UL 94 V-0	1
②	Molded Parts:	PBT, UL 94 V-0	1
③	Terminals(S):	Brass 0.8t	N
④	Terminals(L):	Brass 0.8t	N
⑤	Spring Clamp(S):	PhBz 0.3t	N
⑥	Spring Clamp(L):	PhBz 0.3t	N
⑦	Terminals Screw:	Steel M3	2×N
⑧	Flange Screw:	Steel M3 Zinc plated	2
⑨	Clamp Nut:	Brass 0.8t	2×N
⑩	Cushion:	Steel 0.4t Nickel plated	4
⑪	Locking:	Steel 0.4t Nickel plated	2
⑫	Flange Nut:	Brass M3	2
⑬	Cover:	PC	1

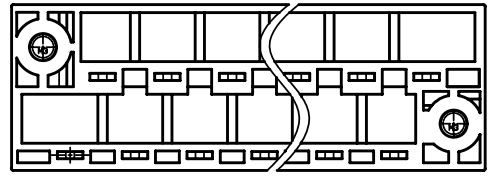
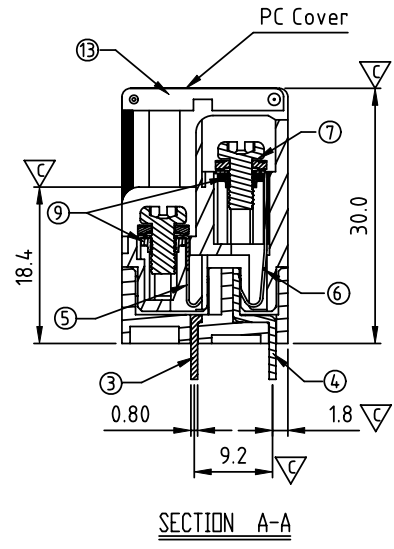
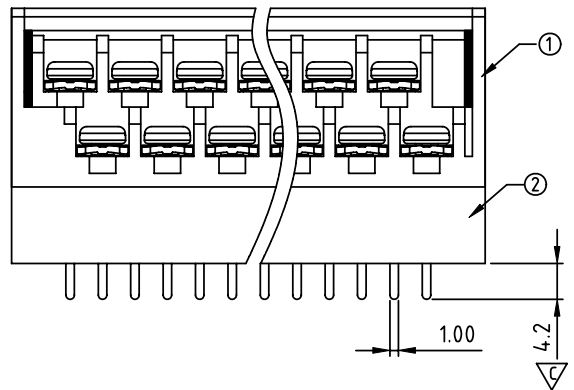
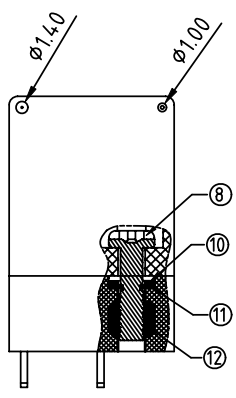

N = Number of poles
 Dim A (N-1)×7.62+17.59
 Dim B (N-1)×7.62

Poles	Dim A	Dim B
2×10P-2×12P	±0.40	±0.40
2×13P-2×16P	±0.50	±0.50
2×17P-2×21P	±0.60	±0.60

YK 661 xx 1 x x 0 x G

RoHS compliant (lead<4%)
 In copper Alloy
 0: GREY (RAL7038)
 1: BLACK (RAL9005)

MARK
 0: "@ " MARK
 1: "ANY " MARK

NO. OF POLES
 20: 2×10 POLES
 22: 2×11 POLES
 42: 2×21 POLES

TERMINAL & SCREW PLATED
 0: TERMINAL & SCREW: G/F
 △1: TERMINAL: G/F, SCREW: ZINC

ANYTEK				CUSTOMER COPY	
ALL RIGHTS RESERVED. REPRODUCTION OR ISSUE TO THIRD PARTIES IN ANY FORM WHATSOEVER IS NOT PERMITTED WITHOUT WRITTEN AUTHORITY FROM THE PROPRIETOR. PROPERTY OF ANYTEK TECHNOLOGY CO., LTD					
TITLE	YK-661 Series With flange & With cover (2×10p ~ 2×21p)				
PART NO.	YK661xx1xx0xG	DWG NO.	8YK0004-661		
APPROVED	CHECKED	DESIGNED	DRAWN	CUST NO.	Tolerance
		Guoxue 2012.12.13	Guoxue 2012.12.13		X. ±0.50 X.X ±0.30 X.XX ±0.10 X° ±1°
				SHEET: 01/01	REV.: C

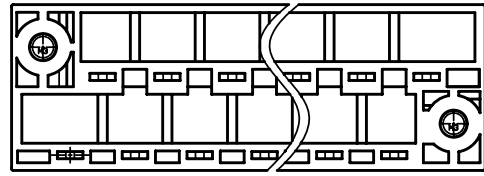
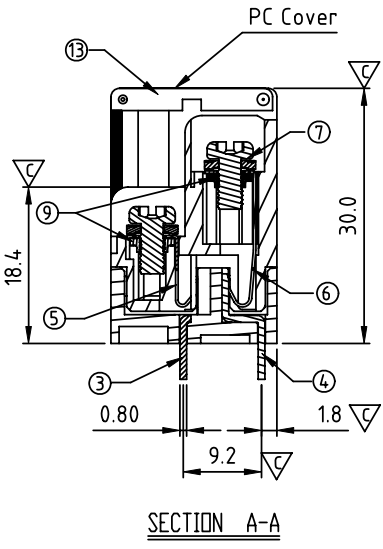
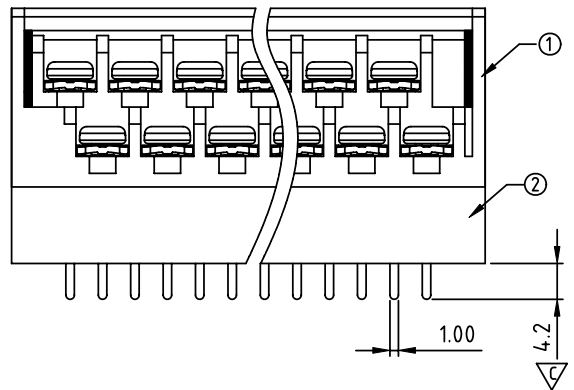
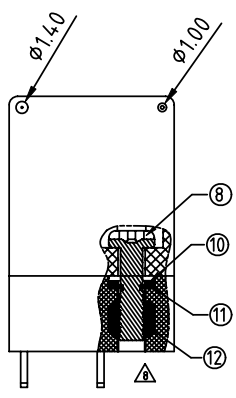
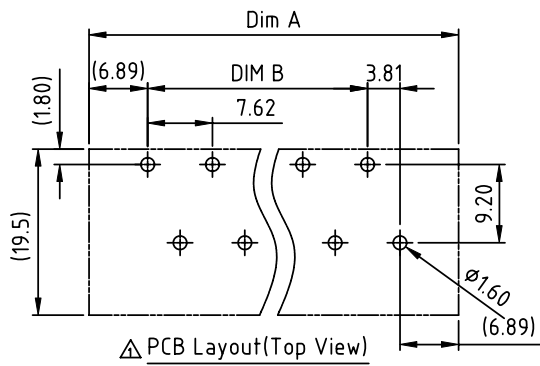
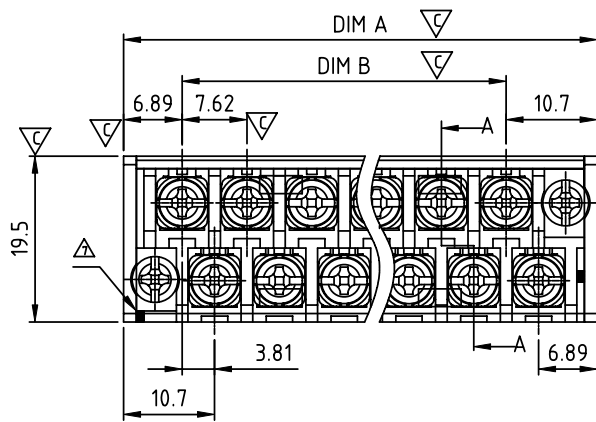

SIGN	DATE	DESCRIPTION	APPROVER
△	11/12'07	PCB Layout changed	Tony
△	5/20'09	Temperature changed from -40°C-105°C to -40°C-115°C	Eris
△	5/20'09	Screw torque value changed from 8Kgf.cm to 7 lb-In	Eris
△	5/20'09	wire range changed from 22-14 AWG to 22-12 AWG	Eris
△	6/29'09	Part NO is Changed	Aaron
△	7/06'09	Add cULus	Aaron
△	5/27'10	The design & Flange Nut is changed	Chen Bo
△	7/05'11	It is changed to insert molding here.	Chen Bo
△	10/21'11	Add the Soldering temperature	Chen Bo
△	05/15'12	The number of poles is changed	Guoxue
△	12/13'12	Change the screw plating specification	Guoxue

THIS IS CAD DRAWING, DO NOT REVISE MANUALLY!!!

MATERIALS ELECTRICAL
RATED VOLTAGE & CURRENT: 300 V, 15 A
WITHSTAND VOLTAGE: AC 2000 V/Min
INSULATION RESISTANCE: 1000 MΩ OR MORE AT DC 500 V
△ OPERATING TEMPERATURE RANG: -40 °C ~ +115 °C
△ SOLDEING TEMPERATURE: 250°C±10°C/5 Sec
△ SCREW TORQUE VALUE: 7Lb-In
△ WIRE RANGE: 22 - 12 AWG
△ Safety Approval: US
Critical dimension:

NO:	Name	Material	Number
①	Molded Parts:	PBT, UL 94 V-0	1
②	Molded Parts:	PBT, UL 94 V-0	1
③	Terminals(S):	Brass 0.8t	N
④	Terminals(L):	Brass 0.8t	N
⑤	Spring Clamp(S):	PhBz 0.3t	N
⑥	Spring Clamp(L):	PhBz 0.3t	N
⑦	Terminals Screw:	Steel M3	2×N
⑧	Flange Screw:	Steel M3 Zinc plated	2
⑨	Clamp Nut:	Brass 0.8t	2×N
⑩	Cushion:	Steel 0.4t Nickel plated	4
⑪	Locking:	Steel 0.4t Nickel plated	2
⑫	Flange Nut:	Brass M3	2
⑬	Cover:	PC	1

N = Number of poles

Dim A (N-1)×7.62+17.59

Dim B (N-1)×7.62

POLES	Dim A	Dim B
2×2P-2×4P	±0.20	±0.20
2×5P-2×8P	±0.30	±0.30
2×9P	±0.40	±0.40

YK 661 xx 1 x x 0 x G

RoHS compliant (lead<4%) In copper Alloy

0: GREY (RAL7038)
 △ 1: BLACK (RAL9005)

MARK
 0: "@ " MARK
 1: "ANY " MARK

NO. OF POLES
 04: 2×2 POLES
 06: 2×3 POLES
 18: 2×9 POLES

TERMINAL & SCREW PLATED
 0: TERMINAL & SCREW: G/F
 △ 1: TERMINAL: G/F, SCREW: ZINC
 2: TERMINAL: Sn, SCREW: G/F
 △ 3: TERMINAL: Sn, SCREW: ZINC

ANYTEK

CUSTOMER COPY

ALL RIGHTS RESERVED. REPRODUCTION OR ISSUE TO THIRD PARTIES IN ANY FORM WHATSOEVER IS NOT PERMITTED WITHOUT WRITTEN AUTHORITY FROM THE PROPRIETOR. PROPERTY OF ANYTEK TECHNOLOGY CO., LTD

TITLE		YK-661 Series With flange & With cover (2p×2p ~ 2×9p)			
PART NO.	YK661xx1xx0xG	DWG NO.	8YK0001-661		
APPROVED	CHECKED	DESIGNED	DRAWN	CUST NO.	Tolerance
		Guoxue 2012.12.13	Guoxue 2012.12.13		X. ±0.50 X.X ±0.30 X.XX ±0.10 X° ±1°
				SHEET: 01/01	REV.: I



Компания «ЭлектроПласт» предлагает заключение долгосрочных отношений при поставках импортных электронных компонентов на взаимовыгодных условиях!

Наши преимущества:

- Оперативные поставки широкого спектра электронных компонентов отечественного и импортного производства напрямую от производителей и с крупнейших мировых складов;
- Поставка более 17-ти миллионов наименований электронных компонентов;
- Поставка сложных, дефицитных, либо снятых с производства позиций;
- Оперативные сроки поставки под заказ (от 5 рабочих дней);
- Экспресс доставка в любую точку России;
- Техническая поддержка проекта, помощь в подборе аналогов, поставка прототипов;
- Система менеджмента качества сертифицирована по Международному стандарту ISO 9001;
- Лицензия ФСБ на осуществление работ с использованием сведений, составляющих государственную тайну;
- Поставка специализированных компонентов (Xilinx, Altera, Analog Devices, Intersil, Interpoint, Microsemi, Aeroflex, Peregrine, Syfer, Eurofarad, Texas Instrument, Miteq, Cobham, E2V, MA-COM, Hittite, Mini-Circuits, General Dynamics и др.);

Помимо этого, одним из направлений компании «ЭлектроПласт» является направление «Источники питания». Мы предлагаем Вам помощь Конструкторского отдела:

- Подбор оптимального решения, техническое обоснование при выборе компонента;
- Подбор аналогов;
- Консультации по применению компонента;
- Поставка образцов и прототипов;
- Техническая поддержка проекта;
- Защита от снятия компонента с производства.



Как с нами связаться

Телефон: 8 (812) 309 58 32 (многоканальный)

Факс: 8 (812) 320-02-42

Электронная почта: org@eplast1.ru

Адрес: 198099, г. Санкт-Петербург, ул. Калинина, дом 2, корпус 4, литера А.