



Computing Solutions



Comprehensive power management, switching, timing, and protection solutions for computing platforms from ON Semiconductor.



www.onsemi.com



Dual-Edge & RPM Modulation Vcore Controllers for IMVP8 Designs

Features of Multi-Phase Dual Edge Architecture

- Current-mode dual-edge modulation for fast initial response to transient loading
- High-performance operational error amplifier
- Accurate total summing current amplifier
- High-impedance differential voltage and total current sense amplifiers
- Phase-to-phase dynamic current balancing
- “Lossless” DCR current sensing for current balancing

Features of Enhanced Single-Phase RPM Architectures

- High performance RPM control system
- Ultralow offset IOU monitor
- Dynamic VID feed-forward
- Programmable droop gain
- Zero droop capable
- Thermal monitor
- Ultra-sonic operation
- Digitally controlled operating frequency

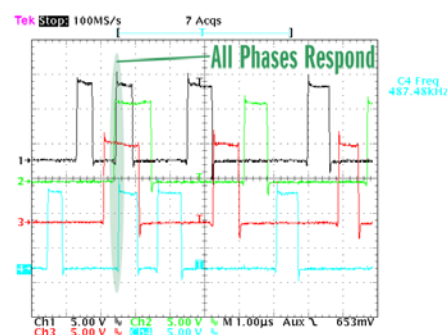
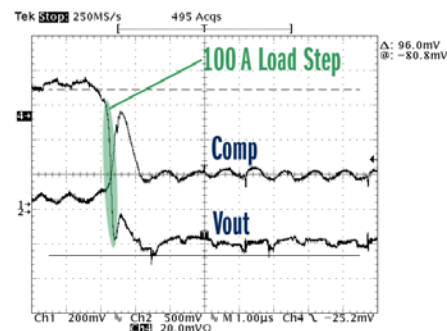

Device	Market	Function	VR Spec	Controller Architecture	Number of Rails	CPU Phases	Integrated Drivers	Interface	Package
NCP81201	Tablet	Controller	VR12.1	RPM	1	1	–	SVID	QFN-28
NCP81111	Microserver	Controller	VR12.5	Hybrid	1	1/2/3	–	SVID	QFN-32
NCP81203	Desktop	Controller	IMVP8	Dual Edge	2	3/2/1+2/1	–	SVID	QFN-52
NCP81203P	Notebook	Controller	IMVP8	Dual Edge	2	3/2/1+2/1	–	SVID	QFN-52
NCP81205	Notebook	Controller	IMVP8	Dual Edge & EN RPM	3	1/2/3+1/2/3+1	–	SVID	QFN-52
NCP81206	Ultrabook	Controller	IMVP8	Dual Edge & EN RPM	3	1+1/2+1	3 x 5V	SVID	QFN-52
NCP81208	Ultrabook	Controller	IMVP8	Dual Edge & EN RPM	3	1+1/2+1	–	SVID	QFN-48
NCP81210	Ultrabook & Notebook	Controller	IMVP8	EN RPM	1	1	1 + FETs	SVID	QFN-40

Please contact ON Semiconductor for product datasheets.

Ultrabook Solution

NCP81208 1+2+1 Phase Controller

- Dual Edge & DCR current sensing for fast transient response
- EN RPM for fast transition between DCM and CCM mode
- True Differential Current Balancing
- IMVP8 compliant

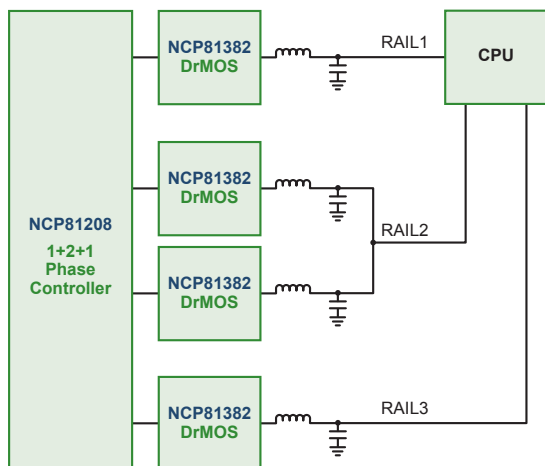

Notebook Solutions

NCP81205 3+3+1 Phase Controller

- Dual Edge & DCR current sensing for fast transient response
- EN RPM for fast transition between DCM and CCM mode
- True Differential Current Balancing
- IMVP8 compliant

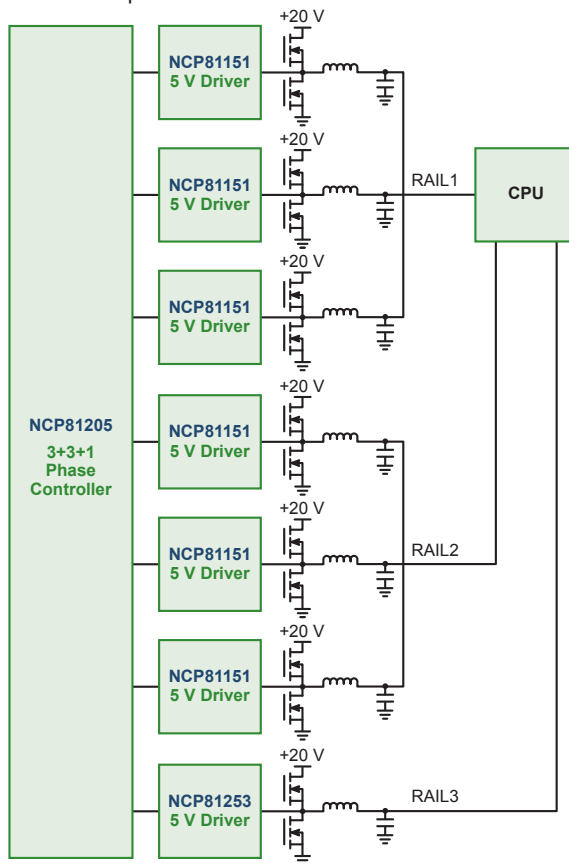

Desktop Solutions

NCP81203 3+2 Phase Controller

- Dual Edge for fast transient response
- Constant on-time for light load efficiency
- Supports all MLCC output capacitor solutions
- IMVP8 compliant

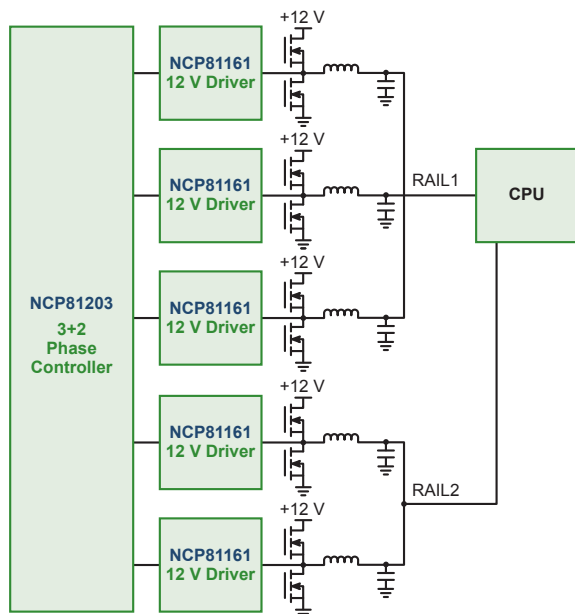

Microserver Solutions

NCP81111 3-Phase Digital Controller

- Optimised to operate at 5MHz using DrMOS
- Can operate as general purpose I2C controller regulator
- Internal compensation using GUI interface
- VR12.5/6 compliant

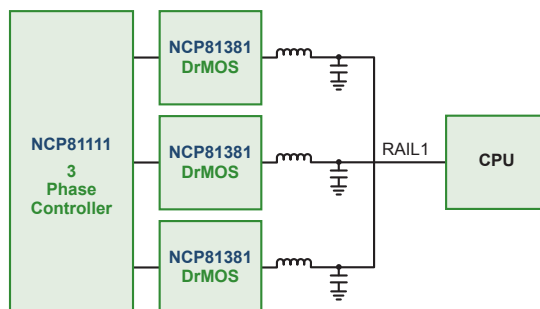

IMVP8 Multiphase Controllers for Embedded Applications

NCP81245 3+3+1 Phase Controller

- Dual Edge & DCR current sensing for fast transient response
- EN RPM for fast transition between DCM and CCM mode
- True Differential Current Balancing
- IMVP8 compliant

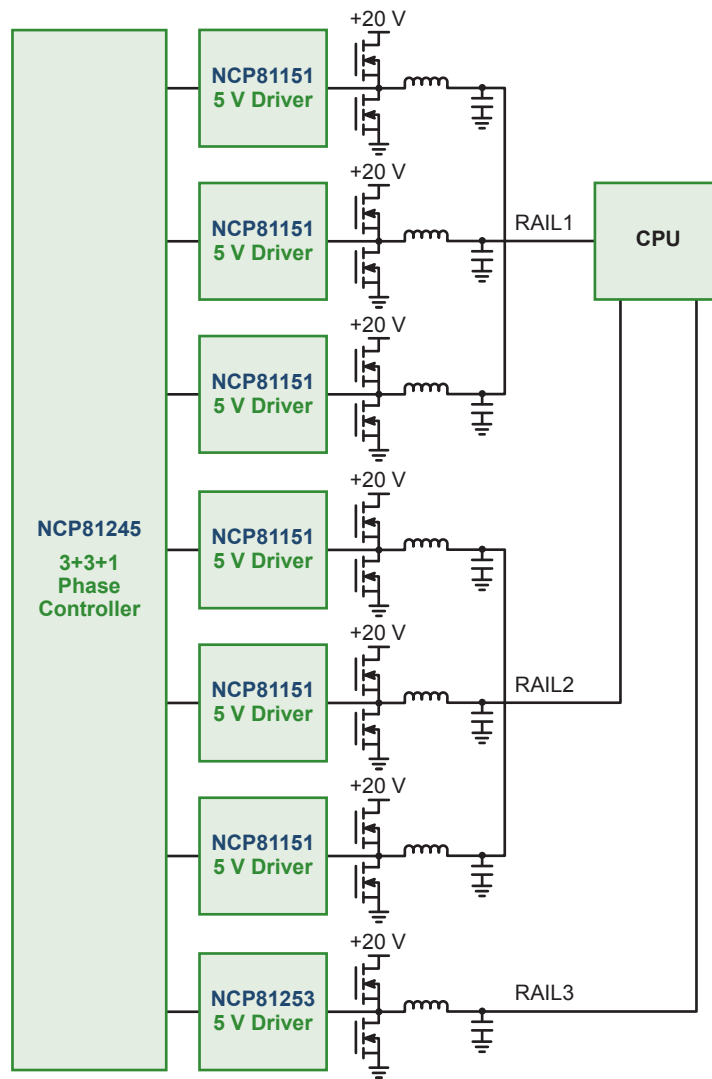

Device	Market	Function	VR Spec	Controller Architecture	Number of Rails	CPU Phases	Integrated Drivers	Interface	Package
NCP81243	Desktop	Controller	IMVP8	Dual Edge	2	3/2/1+2/1	–	SVID	QFN-52
NCP81245	Notebook	Controller	IMVP8	Dual Edge & EN RPM	3	1/2/3+1/2/3+1	–	SVID	QFN-52
NCP81246	Ultrabook	Controller	IMVP8	Dual Edge & EN RPM	3	1+1/2+1	3 x 5 V	SVID	QFN-52
NCP81248*	Ultrabook	Controller	IMVP8	Dual Edge & EN RPM	3	1+1/2+1	-	SVID	QFN-48
NCP81255*	Ultrabook & Notebook	Controller	IMVP8	EN RPM	1	1	1 + FETs	SVID	QFN-40
NCP81145	Ultrabook & Notebook	5 V Driver	–	for Dual Edge Rail	–	–	–	–	DFN-8
NCP81146	Desktop	12 V Driver	–	for Dual Edge Rail	–	–	–	–	DFN-8
NCP81253	Ultrabook & Notebook	5 V Driver	–	for EN RPM rail	–	–	–	–	DFN-8

* Pending 1H16.

System Power

System power management devices provide additional rails in computing applications, beyond Vcore and graphics. They are available with single or dual channel operation, and also in multi-phase configurations.

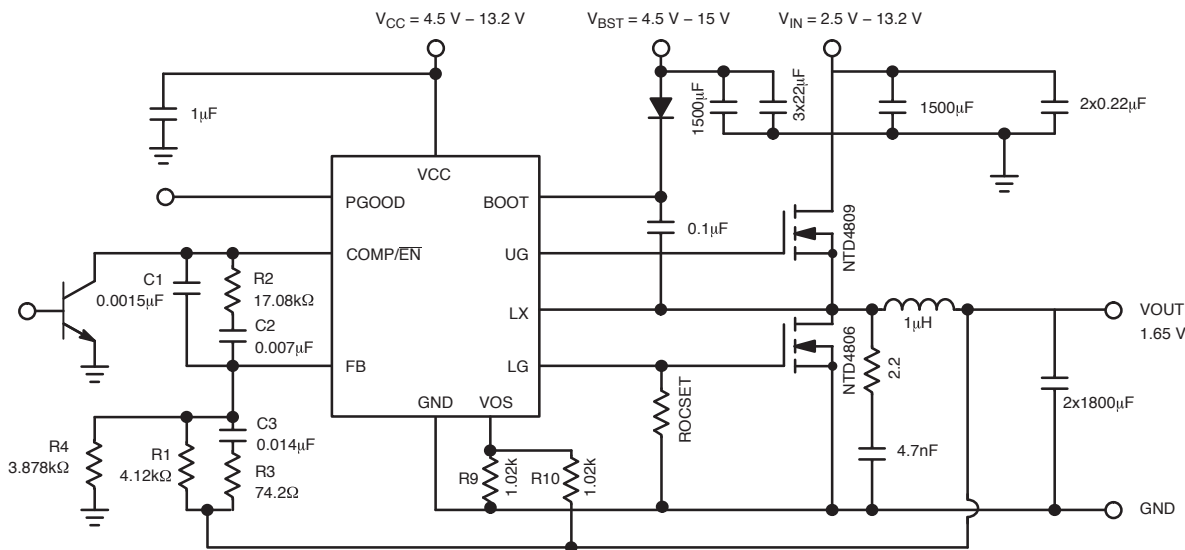

NCP1589A Application Diagram

Device	Description	Topology	V _{CC} Min (V)	V _{CC} Max (V)	f _{sw} Typ (kHz)	Package
NCP1579	Synchronous Buck Controller, Low Voltage	Step-Down	4.5	13.2	275	SOIC-8
NCP1587	Synchronous Buck Controller, Low Voltage	Step-Down	4.5	13.2	250 - 300	SOIC-8
NCP1587A	Synchronous Buck Controller, Low Voltage	Step-Down	4.5	13.2	180 - 220	SOIC-8
NCP1589A	Synchronous Buck Controller, Low Voltage	Step-Down	4.5	13.2	–	DFN-10
NCP1589D	Synchronous Buck Controller	Step-Down	4.5	13.2	–	DFN-10
NCP1589L	Synchronous Buck Controller, Low Voltage, with Light Load Efficiency and Transient Enhancement	Step-Down	4.5	13.2	–	DFN-10
NCP5212	Single Synchronous Step Down Controller	Step-Down	4.5	27	300	QFN-16
NCP5217	Synchronous Buck Controller, Single	Step-Down	4.5	27	300	QFN-14
NCP5230	Low Voltage Synchronous Buck Controller	Step-Down	4.5	13.2	–	QFN-16
NCP5269	System Agent Controller with 2-bit VID	Step-Down	3.3	28	300 - 600	QFN-20
NCP3231	25 A Synchronous Buck Converter with Intergrated MOSFETs	Step-Down	4.5	18	500	TQFN-40
NCP3232N	15 A Synchronous Buck Converter with Intergrated MOSFETs	Step-Down	4.5	21	500	TQFN-40
NCP3133A	3 A Synchronous Buck Converter with Intergrated MOSFETs	Step-Down	2.9	5.5	1100	QFN-16
NCP3135	5 A Synchronous Buck Converter with Intergrated MOSFETs	Step-Down	2.9	5.5	1100	QFN-16

Thermal Management and System Monitoring

Extensive Portfolio

Local Sensors provide temperature information at the device location

Remote Sensors provide temperature information of a transistor located at a different position on the board; also includes local sensor capability

Fan Controllers integrate the temperature sensor with a fan controller/monitor

System Monitors integrate combinations of remote and/or local temperature sensing, voltage monitoring, fan control & monitoring, reset control, and GPIO functions

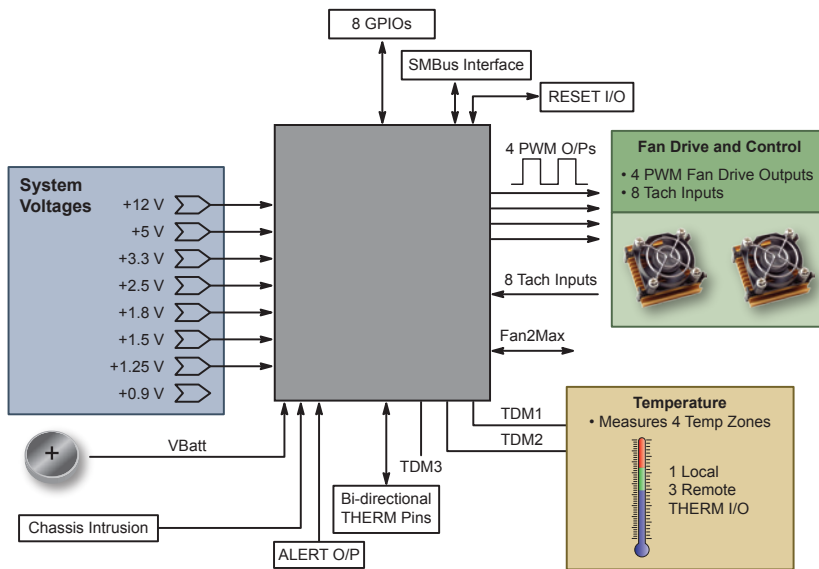

	Device	Supply Range (V)	Temperature Range (°C)	Local Accuracy (°C)	Interface	Number of Addresses	SRC (Ω)	Remote Accuracy	Remote Channels	Fan Channels	TACH Channels	Voltage Monitoring Channels	GPIOs	Package
System Monitors	ADM1026	3 - 5.5	-40 to +120	±3	I2C/SMBUS	3	–	±3	2	8	8	19	17	LQFP-48
	ADT7462	3 - 5.5	-40 to +125	±2.25	I2C/SMBUS	2	2 k	±2.25	3	4	8	13	8	LFCSOP-32
	NCT80	2.8 - 5.75	-40 to +125	±2	I2C/SMBUS	8	–	–	–	–	2	7	1	TSSOP-24
	ADT7476	3 - 3.6	-40 to +120	±1.5	I2C/SMBUS	3	–	±1.5	2	3	4	5	–	QSOP-24
Fan Controllers	ADT7473	3 - 3.6	-40 to +120	±1.5	I2C/SMBUS	3	3 k	±1.5	2	3	4			QSOP-16
	ADT7475	3 - 3.6	-40 to +120	±1.5	I2C/SMBUS	1	–	±1.5	2	3	4			QSOP-16
	ADM1033	3 - 3.6	-40 to +120	±1	I2C/SMBUS	8	1 k	±1	1	1	1			QSOP-16
	ADM1034	3 - 3.6	-40 to +120	±1	I2C/SMBUS	8	1 k	±1	2	2	2			QSOP-16
Remote Sensors	NCT72	2.8 - 3.6	-40 to +125	±1	I2C/SMBUS	2	1.5 k	±1	1					DFN-8, WDFN-8
	NCT218	1.4 - 2.75	-40 to +125	±1.75	I2C/SMBUS	2	150	±1	1					WDFN-8, WLCSOP-8
	NCT210	3 - 5.5	-55 to +125	±1	I2C/SMBUS	9	–	±3	2					QSOP-16
	ADM1032	3 - 5.5	-40 to +125	±3	I2C/SMBUS	2	–	±1	1					SOIC-8, MSOP-8
	ADT7461	3 - 5.5	-40 to +125	±3	I2C/SMBUS	2	3 k	±1	1					SOIC-8, MSOP-8
	ADT7481	3 - 3.6	-40 to +125	±1	I2C/SMBUS	2	–	±1	2					MSOP-10
	ADT7483	3 - 3.6	-40 to +125	±1	I2C/SMBUS	9	–	±1	2					QSOP-16
Local Sensors	NCT375	3 - 5.5	-55 to +125	±1	SMBUS	8								DFN-8, SOIC-8, Micro8
	NCT475	3 - 5.5	-55 to +125	±1	SMBUS	4								WLCSOP-6
	NCT203	1.4 - 2.75	-40 to +125	±1.75	I2C/SMBUS	1								DFN-8, SOIC-8, Micro8

Integrated MOSFET and Drivers

Features

- Integrated high- and low-side MOSFETs
- Integrated bootstrap diode
- Matched of driver and MOSFETs optimize switching performance
- Higher switching frequency enables use of smaller inductor and output capacitors
- Low-side MOSFET diode emulation mode provides asynchronous operation
- 65% lower BOM; 45% smaller footprint and simplified layout versus discrete solutions

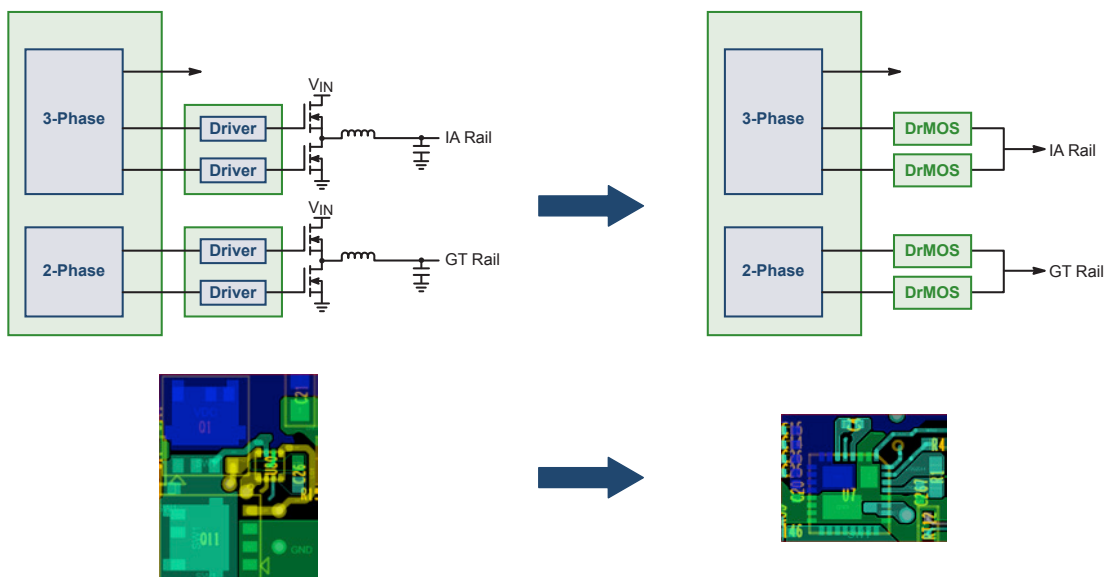

Discrete

versus

Integrated

Device	PWM Input	V _{IN} Max (V)	Freq Max (MHz)	I _{OUT} Continuous Max (A)	Package
NCP5369	5 V Tri-state	25	1	40	QFN-40
NCP81081	3.3 V Tri-state	25	1	40	QFN-40
NCP5338	5 V Tri-state	20	1	40	QFN-40
NCP81380	5 V Tri-state	30	2	15	QFN-32
NCP81381	5 V Tri-state	30	2	25	QFN-32
NCP81382	5 V Tri-state	30	2	35	QFN-28

Drivers for Discrete MOSFET Implementations

Drivers specifically designed to work with controller solutions, and optimized for 5 V or 12 V gate applications.

Device	Drivers	V _{CC} Typ (V)	Integrated Bootstrap Diode	Zero Crossover Detection	Package
NCP5901	Single	12	N	Y	DFN-8
NCP5901B	Single	12	Y	Y	DFN-8
NCP81161	Single	12	Y	Y	DFN-8
NCP81151	Single	5	Y	Y	DFN-8
NCP81253	Single	5	Y	N	DFN-8
NCP81061	Dual	12	Y	Y	QFN-16
NCP81152	Dual	5	Y	Y	QFN-16

MOSFETs Provide Optimized Efficiency



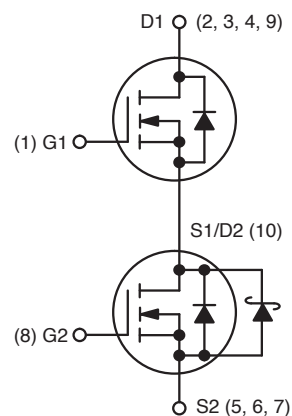

Asymmetric Dual

- Co-packaged Power Stage to minimize board space
- Low Side MOSFET with Integrated Schottky
- Parasitic Inductances Minimized
- Optimized Devices to Reduce Power Losses



Device	Package	Config	Polarity	Maximum Rating				Q _g (nC)	Q _{gd} (nC)	C _{iss} (pF)	C _{rss} (pF)	R _G (Ω)	Applications
				V _{DS} (V)	V _{GS} (V)	R _{DS(on)} (mΩ)							
						V _{GS} =10 V	V _{GS} =4.5 V						
NTMFD4C85N	PowerPhase	Asym Dual	N	30	20	3.0	4.3	15.0	5.2	1960	102	1.0	Control Side
			N	30	20	0.8	1.2	45.2	11.8	6660	126	1.0	Synchronous Side
NTMFD4C86N	PowerPhase	Asym Dual	N	30	20	5.4	8.1	10.9	5.4	1252	126	1.0	Control Side
			N	30	20	2.1	3.0	21.6	5.5	3040	77	1.0	Synchronous Side
NTMFD4901NF	SO-8FL	Asym Dual	N	30	20	6.5	10.0	9.7	3.7	1150	105	0.8	Control Side
			N + Int Sch	30	20	2.4	3.5	20.0	5.3	2950	82	0.8	Synchronous Side
NTMFD4C87N	PowerPhase	Asym Dual	N	30	20	5.0	7.7	10.9	5.4	1252	129	1.0	Control Side
			N	30	20	3.1	4.3	13.8	3.6	1939	49	1.0	Synchronous Side
NTMFD4C20N	SO-8FL	Asym Dual	N	30	20	7.0	10.8	9.3	4.2	970	125	1.0	Control Side
			N	30	20	3.4	5.2	13.0	3.0	1950	50	1.0	Synchronous Side
NTMFD4902NF	SO-8FL	Asym Dual	N	30	20	6.5	10.0	9.7	3.7	1150	105	0.8	Control Side
			N + Int Sch	30	20	4.1	6.2	11.5	3.4	1510	83	0.8	Synchronous Side
NTLLD4901NF	μ8-FL/WDFN-8	Asym Dual	N	30	20	20.0	30.0	5.5	1.4	605	100	0.8	Control Side
			N + Int Sch	30	20	15.0	22.0	5.9	2.9	645	16	0.8	Synchronous Side

MOSFETs Provide Optimized Efficiency

	Device	Package	Configuration	Polarity	Maximum Rating				Q _g (nC)	Q _{gd} (nC)	C _{iss} (pF)	C _{rss} (pF)	R _g (Ω)	Applications
					V _{DS} (V)	V _{GS} (V)	R _{DS(ON)} (mΩ)							
							V _{GS} = 10 V	V _{GS} = 4.5 V						
 <p>SO-8FL 5 x 6 mm</p>	NTMFS4C01N	SO-8FL	Single	N	30	20	0.9	1.2	65.0	18.0	9200	231	1.0	HPPC
	NTMFS4C03N	SO-8FL	Single	N	30	20	2.1	2.8	43.7	5.3	2850	72	1.0	HPPC
	NTMFS4983NF	SO-8FL	Integ Sch	N	30	20	2.1	3.1	22.6	6.9	3250	90	1.0	Synchronous Side
	NTMFS4C35N	SO-8FL	Single	N	30	20	3.2	4.2	15.0	5.5	2300	46	1.0	Synchronous Side
	NTMFS4985NF	SO-8FL	Integ Sch	N	30	20	3.4	5.0	14.2	4.2	2100	60	1.0	Synchronous Side
	NTMFS4C05N	SO-8FL	Single	N	30	20	3.4	5.0	13.0	3.0	1950	50	1.0	Synchronous Side
	NTMFS4C06N	SO-8FL	Single	N	30	20	4.0	6.0	14.5	5.5	1988	71	1.0	Synchronous Side
	NTMFS4C08N	SO-8FL	Single	N	30	20	5.8	8.5	8.7	2.8	1100	38	1.0	Synchronous Side
	NTMFS4C09N	SO-8FL	Single	N	30	20	6.0	8.8	10.9	5.4	1252	126	1.0	Control Side
	NTMFS4C10N	SO-8FL	Single	N	30	20	7.0	10.8	9.3	4.2	970	125	1.0	Control Side
	NTMFS4C13N	SO-8FL	Single	N	30	20	9.1	13.8	6.6	2.7	720	95	1.0	Control Side
 <p>μ8FL 3.3 x 3.3 mm</p>	NTTFS4C05N	μ8-FL	Single	N	30	20	3.6	5.1	13.0	3.0	1950	50	1.0	Synchronous Side
	NTTFS4C06N	μ8-FL	Single	N	30	20	4.0	6.0	14.5	5.5	1988	71	1.0	Synchronous Side
	NTTFS4C08N	μ8-FL	Single	N	30	20	5.8	8.5	8.7	2.8	1100	38	1.0	Synchronous Side
	NTTFS4C10N	μ8-FL	Single	N	30	20	7.4	11.0	9.3	4.2	970	125	1.0	Control Side
	NTTFS4C13N	μ8-FL	Single	N	30	20	9.1	13.8	6.6	2.7	720	95	1.0	Control Side
	NTTFS4C25N	μ8-FL	Single	N	30	20	17.0	26.5	4.0	1.3	455	60	1.0	Control Side
 <p>DPAK</p>	NTD4904N	DPAK	Single	N	30	20	3.7	5.5	16.8	3.0	3052	23.0	1.0	Synchronous Side
	NTD4965N	DPAK	Single	N	30	20	4.7	7.0	17.5	8.5	1684	330	0.8	Synchronous Side
	NTD4906N	DPAK	Single	N	30	20	5.5	8.0	11.0	1.8	1932	19	1.0	Synchronous Side
	NTD4969N	DPAK	Single	N	30	20	9.0	12.0	8.7	4.0	835	163	0.7	Control Side
	NTD4970N	DPAK	Single	N	30	20	11.0	15.0	7.7	3.7	743	330	0.9	Control Side
 <p>SOIC-8 5 x 6 mm</p>	NTMS4937N	SOIC-8	Single	N	30	20	6.5	8.7	17.4	3.3	2563	25	1.0	Synchronous Side
	NTMS4939N	SOIC-8	Single	N	30	20	8.4	11.0	12.4	1.9	2000	16	0.7	Synchronous Side
	NTMS4916N	SOIC-8	Single	N	30	20	9.0	12.0	14.0	7.0	1468	280	0.7	Control Side
	NTMS4917N	SOIC-8	Single	N	30	20	11.0	15.0	10.8	3.5	1132	216	0.7	Control Side
	NTMS4800N	SOIC-8	Single	N	30	20	20.0	27.0	7.7	3.2	940	125	1.5	Control Side
	NTMS4840N	SOIC-8	Single	N	30	20	24.0	36.0	4.8	1.9	520	70	2.0	Control Side
	NTMD4820N	SOIC-8	Dual	N	30	20	20.0	27.0	7.7	3.2	940	125	1.5	DC-DC, Load Switch
	NTMD4840N	SOIC-8	Dual	N	30	20	24.0	36.0	4.8	1.9	520	70	1.0	DC-DC, Load Switch
	NTMS4177P	SOIC-8	Single	P	-30	20	12.0	19.0	29.0	13.0	3100	370	2.0	Load Switch
	NTMS4176P	SOIC-8	Single	P	-30	25	18.0	30.0	17.0	8.4	1720	256	2.9	Load Switch

MOSFETs Provide Optimized Efficiency

Trench 6 High Efficiency (TGHE) for Servers and Point-of-Load Modules

- High Efficiency DC-DC Conversion
- Integrated Schottky LowSides
- Lowest RDS(on) in the industry



Device	Package	Config	Polarity	Maximum Rating				Q _g (nC)	Q _{gd} (nC)	C _{iss} (pF)	C _{rss} (pF)	R _G (Ω)	Applications
				V _{DS} (V)	V _{GS} (V)	R _{DS(ON)} (mΩ)							
						V _{GS} =10 V	V _{GS} =4.5 V						
NTMFS4H01N	SO-8FL	Single	N	25	20	0.7	1.0	39.0	8.5	5693	212	1.2	Synchronous Side
NTMFS4H01NF	SO-8FL	Integ Sch	N	25	20	0.7	1.0	37.8	8.0	5538	175.3	1.3	Synchronous Side
NTMFS4H013NF	SO-8FL	Integ Sch	N	25	20	0.9	1.3	28.0	7.5	3780	150	1.0	Synchronous Side
NTMFS4H02N	SO-8FL	Single	N	25	20	1.4	2.2	18.0	4.2	2651	103	1.0	Synchronous Side
NTMFS4H02NF	SO-8FL	Integ Sch	N	25	20	1.4	2.3	18.7	4.3	2652	94	1.0	Synchronous Side
NTTFS4H05N	μ8-FL	Single	N	25	20	3.3	4.8	8.7	1.9	1205	45	1.0	Control Side
NTTFS4H07N	μ8-FL	Single	N	25	20	4.8	7.1	5.7	1.3	771	34	1.0	Control Side

Switching Devices

ON Semiconductor offers a range of switching devices for high speed interface in servers, desktop computing, notebook and netbook computers. Applications include PCI Express, DisplayPort, Gigabit Ethernet and USB 2.0.

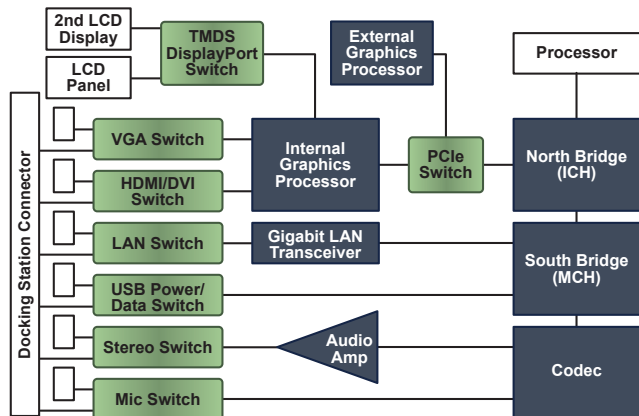

Server Implementation

Device	Interface	Data Rate	No Channels	Quiescent Current
NCN3612B	PCIe 3.0, DisplayPort 1.2	8 Gb/s	12	250 μA
NCN3411	PCIe 3.0	8 Gb/s	8	200 μA
NCN2612B	PCIe 2.0, DisplayPort 1.1	5 Gb/s	12	250 μA
NS3L500	Gigabit Ethernet	1 Gb/s	11	250 μA
NCN1188	USB 2.0 / MHL	2.25 Gb/s	2	21 μA
NS5S1153	USB 2.0	480 Mb/s	2	21 μA
NLAS7242	USB 2.0	480 Mb/s	2	1 μA
NLAS52231	Audio	36 MHz	2	1 μA
NLAS4684	Audio	9.5 MHz	2	180 nA

Advanced Load Switches

ON Semiconductor provides a comprehensive range of load switches, suitable for a variety of different power trees.

- Copackaged MOSFET plus CMOS controllers – value-added features plus high performance
- Monolithic CMOS smart load switches – value added features, low cost
- Discrete MOSFETs – simple, high performance

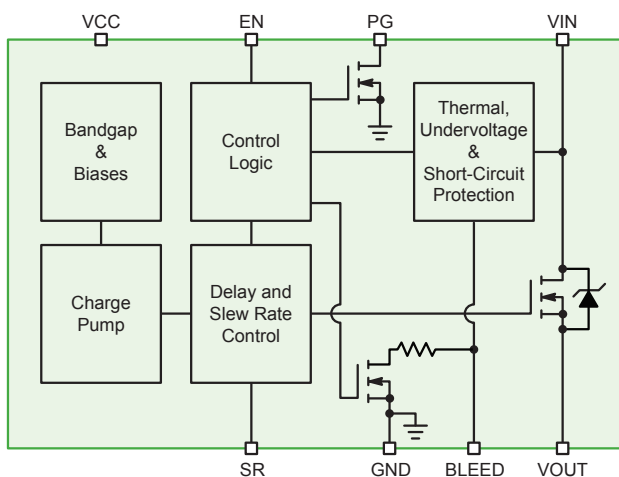

NCP45xxx Integrated Load Switch Feature

- Simple/clean design
- No current consumption in standby power mode
- Small PCB footprint
- Low RDS(ON) due to charge pump driving NMOS
- Adjustable soft-start time (SR)
- Adjustable integrated discharge
- Fault protection
- Power rail monitoring & sequencing

Type	Device	r _{on} (mΩ)	I Max (A)	V _I Min (V)	V _I Max (V)	I _q (μA)	Discharge	Slew Rate (μs)	Features	Package(s)
Smart Load Switch	NCP330	26 at 3.3 V	3	1.8	5.5	100	-	2000	Reverse blocking	TDFN-4
	NCP333	55 at 3.3 V	1.5	1.2	5.5	1	Auto	95	-	WLCSP-4
	NCP334	47 at 3.3 V	2	1.2	5.5	1	-	71	-	WLCSP-4
	NCP335	47 at 3.3 V	2	1.2	5.5	1	Auto	71	-	WLCSP-4
	NCP336	23 at 3.3 V	3	1.2	5.5	1	-	810	-	WLCSP-6
	NCP337	23 at 3.3 V	3	1.2	5.5	1	Auto	810	-	WLCSP-6
	NCP338	27 at 1.8 V	2	1	3.6	0.6	Auto	20	-	WLCSP-6
	NCP339	26 at 3.3 V	3	1.2	5.5	2	-	2700	Reverse blocking	WLCSP-6
	NCP432	50 at 1.8 V	1.5	1	3.6	0.6	-	20	-	WLCSP-4
	NCP433	50 at 1.8 V	1.5	1	3.6	0.6	Auto	20	-	WLCSP-4
	NCP434	43 at 1.8 V	2	1	3.6	0.6	-	61	-	WLCSP-4
	NCP435	43 at 1.8 V	2	1	3.6	0.6	Auto	61	-	WLCSP-4
	NCP436	23 at 1.8 V	3	1	3.6	1	-	27	-	WLCSP-6
	NCP437	23 at 1.8 V	3	1	3.6	1	Auto	27	-	WLCSP-6
ecoSWITCH™ Integrated Load Switch	NCP45524	18.0	6	0.5	13.5	-	Adj	-	Power good	DFN-8
	NCP45525	18.0	6	0.5	13.5	-	Adj	Adj	-	DFN-8
	NCP45560	2.4	24	0.5	13.5	-	Adj	Adj	Power good; Fault	DFN-12
	NCP45540	3.3	20	0.5	13.5	-	Adj	Adj	Power good; Fault	DFN-12
	NCP45541	3.3	20	0.5	13.5	-	Adj	Adj	Power good	DFN-12
	NCP45520	9.5	10.5	0.5	13.5	-	Adj	-	Power good; Fault	DFN-8
	NCP45521	9.5	10.5	0.5	13.5	-	Adj	Adj	Fault	DFN-8

Electronic Fuse (eFuse) for SAS, SATA, eSATA, USB

3.3 V, 5 V, and 12 V Power Bus Protection

Features

- Low RDS(ON), high operating and trip currents (IOP, ITRIP)
- Overvoltage protection
- Precise ITRIP control
- Slew rate control
- Thermal shut-down
- EN pin for synchronizing multiple eFuses
- Outperforms poly-fuses:
 - Tighter spec tolerances
 - Lower resistance
 - Lower trip-time
 - Superior repeatability

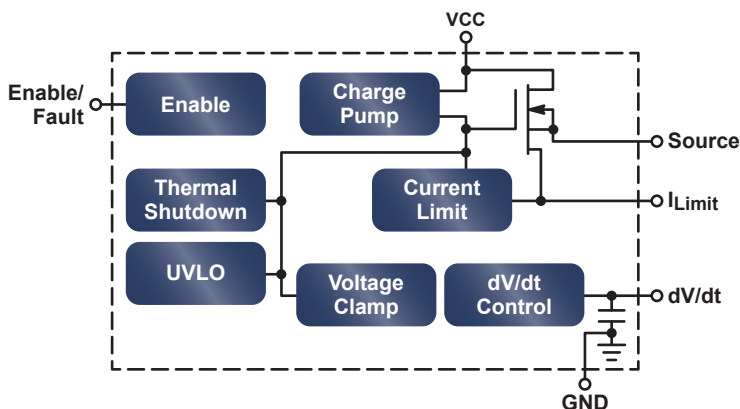

Typical Feature Set for eFuse

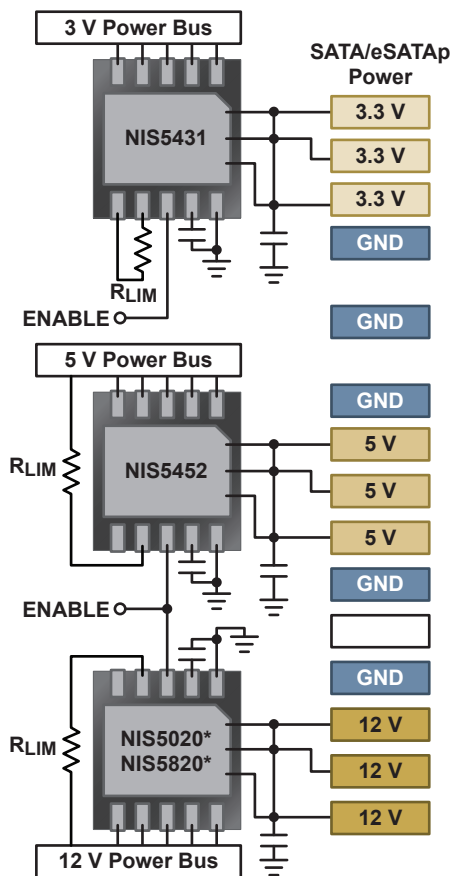

Device	Input Voltage (V)	Output Clamping Voltage (V)	ITRIP Trip Current (A)	RDS(ON) (mΩ)	Auto Recovery Option	Latching Option	Package
NIS5112	-0.6 to 18	15	2.5 (adjustable)	28	Yes	Yes	SOIC-8
NIS5132	-0.6 to 18	15	3.5 (adjustable)	44	Yes	Yes	DFN-10
NIS5232	-0.6 to 18	15	4.0 (adjustable)	44	No	Yes	DFN-10
NIS5135	-0.6 to 18	6.65	3.5 (adjustable)	68	Yes	Yes	DFN-10
NIS5452*	-0.6 to 14	5.85	3.5 (adjustable)	33	Yes	Yes	WDFN-10
NIS5431*	-0.6 to 14	3.85	2.0 (adjustable)	40	No	Yes	WDFN-10

* Pending 1H16.

Ethernet: 10/100BASE-T, 1000BASE-TX, and Gigabit

Four Pairs, Low Capacitance Surge and ESD Protection

The 1000BASE-T or Gigabit Ethernet interface operating at higher bitrates is susceptible to ESD strikes, cable-discharge events and lightning-induced transients. Our products help meet IEC 61000-4-5, GR-1089-CORE and other Standards.

Features

- Line-to-line capacitance < 3 pF
- V_{clamp} (25 A surge) < 11 V
- IEC 61000-4-2 rating > 30 kV
- No latching danger
- Surge rating maintained to 125°C

Benefits

- Compatible with Gb Ethernet and beyond
- Enhanced protection for downstream electronics
- Accommodates operating transients above 3.3 V
- Small form-factor allows integration into connectors

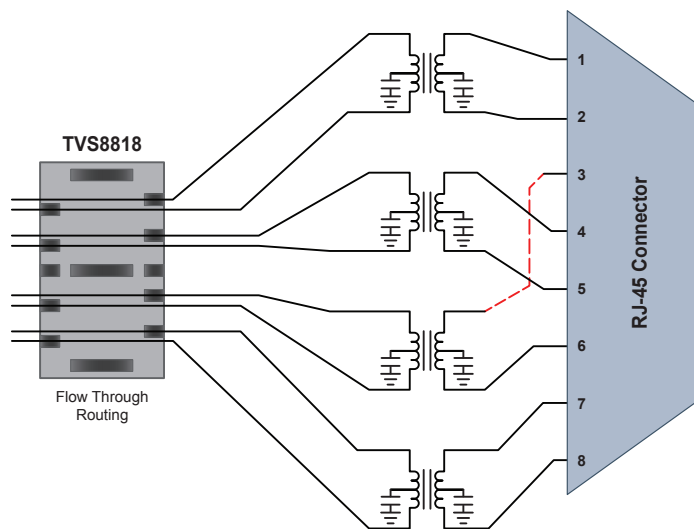

Typical Application

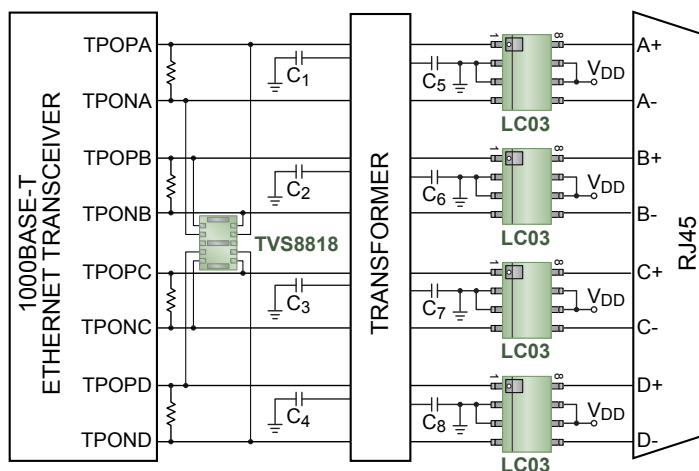

Line Side : LC03-6 (optional)
Transformer Side: TVS8818
Protection against metallic (transverse) strikes

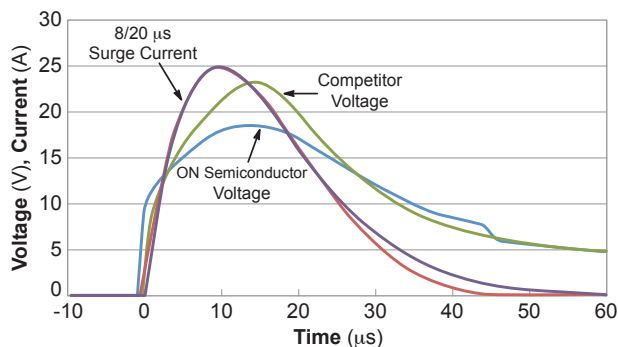

Line-to-Line Surge

Transient Voltage Suppressors

Device	V_{DC} Max (V)	Line Transient Max (V)	Surge I_{PP} , 8/20 μ s (A)	Typical Line-Line Capacitance (pF)	ESD Contact Rating (kV)	Package
LC03-6	6.7	7.0	100	8.0	\pm 30	SOIC-8
TVS4201	5.0	6.0	25	1.5	\pm 30	TSOP-6
TVS8814	3.0	3.2	35	1.5	\pm 30	UDFN-8
TVS8818	3.0	3.2	35	1.5	\pm 30	UDFN-10
NUP4114H	5.0	5.0	12*	0.4	\pm 13	TSOP-6
SRDA3.3	3.3	5.0	25	4.0	\pm 8	SOIC-8
SRDA05	5.0	7.0	23	5.0	\pm 8	SOIC-8

* On Pin 5.

USB 3.x Type A Connector

Two SuperSpeed Pairs, One High Speed Pair, V_{CC}, Low Capacitance ESD Protection

Key Requirement

- Cap < 0.7 pF

Features

- 0.35 pF
- Flow through routing
- Industry leading low clamping voltage versus competitors

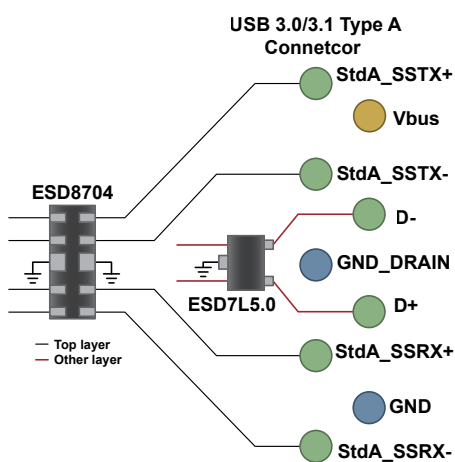
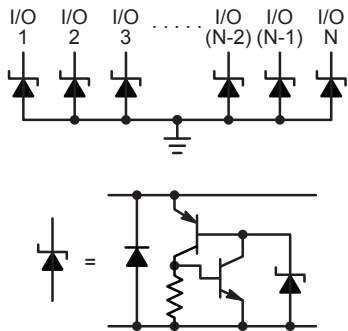

ESD8704 – 0.35 pF, 2 Layer Routing
(ESD8704; ESD7L5.0 for D+, D- Lines)

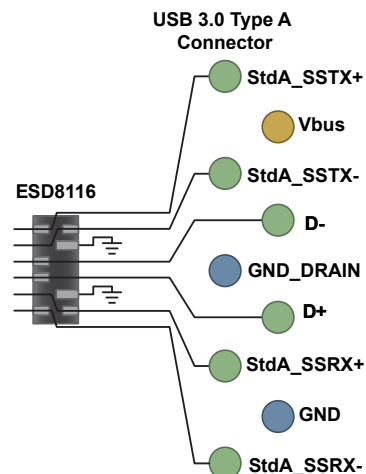

ESD8116 – 0.30 pF, 1 Layer Routing

Device	Interface	Data Lines	Capacitance (pF)	Package	Size (mm)
ESD8704*	USB 3.x	2 Pair (Tx, Rx)	0.35	UDFN-10	2.5 x 1.0
ESD7L	USB 3.x	1 Pair (D+/-)	0.5	SOT-723	1.2 x 1.2
ESD8504	USB 3.0	2 Pair (Tx, Rx)	0.4	UDFN-10	2.5 x 1.0
ESD8104	USB 3.0	2 Pair (Tx, Rx)	0.3	UDFN-10	2.5 x 1.0
ESD8116	USB 3.0	3 Pair (Tx, Rx, D+/-)	0.3	UDFN-8	2.0 x 1.2
ESD8011	USB 3.x	Single Line	0.10	X3DFN-2	0.62 x 0.32
ESD8101	USB 3.x	Single Line	0.20	DSN-2	0.43 x 0.23
ESD8111	USB 3.x	Single Line	0.20	WLCSP-2	0.6 x 0.3
ESD8006	USB 3.0	3 Pair (Tx, Rx, D+/-)	0.25	UDFN-8	3.3 x 1.0

* Pending 1H16.

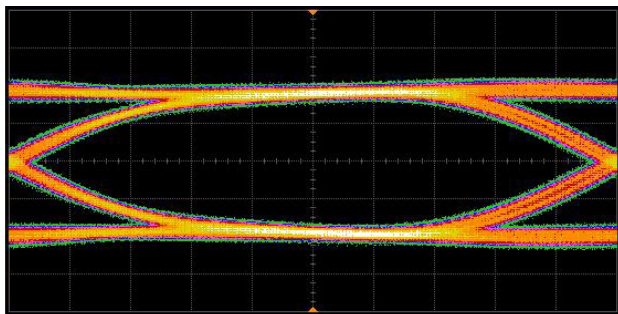

Without ESD

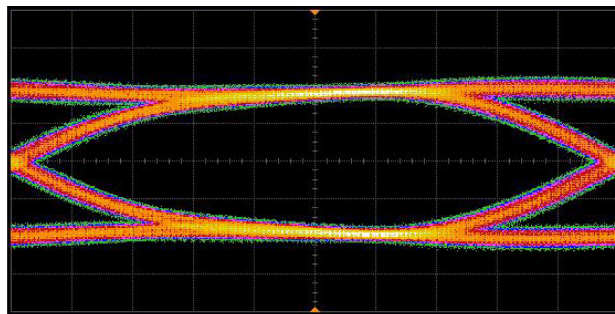

With ESD

USB 3.0 @ 5 Gb/s

USB 3.x Type C Connector

Key Requirement

- Cap < 0.5 pF

Features

- 0.35 pF
- Flow through routing
- Industry leading low clamping voltage versus competitors

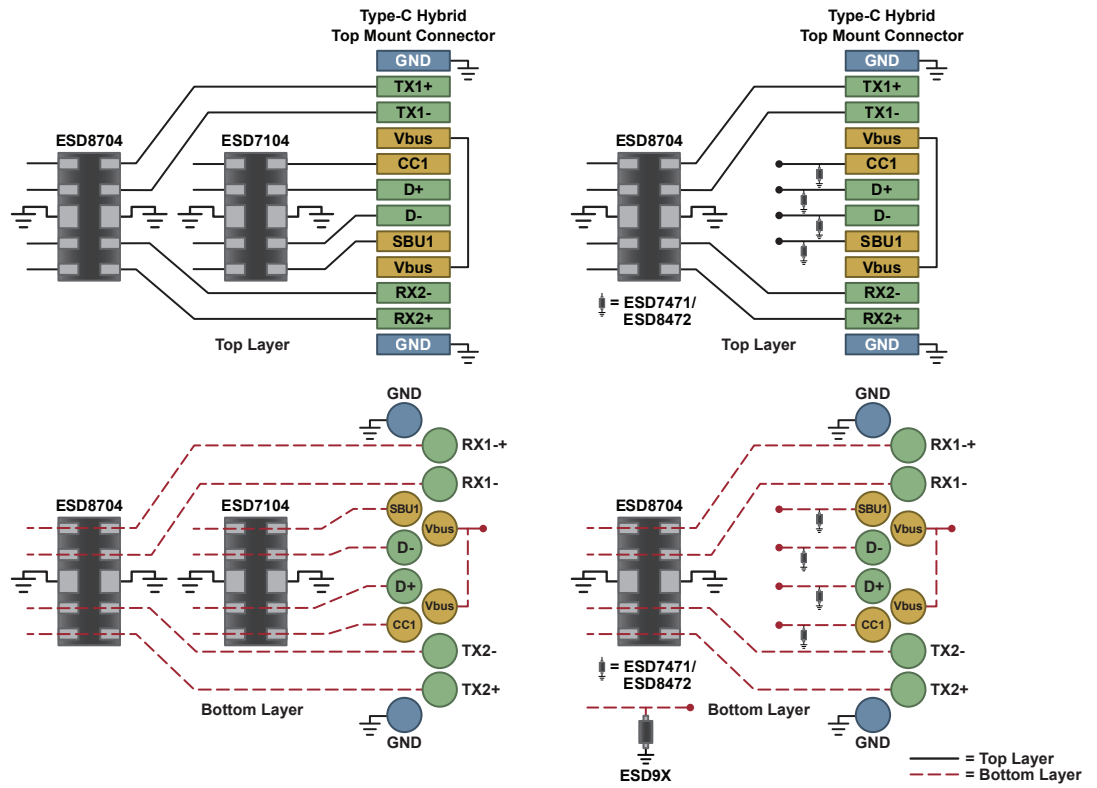

Device	Data Lines	Capacitance (pF)	Package	Size (mm)
ESD8704*	2 Pair (Tx, Rx)	0.37	UDFN-10	2.5 x 1.0
ESD7104	2 Pair (CC, SBU, D+/-)	0.30	UDFN-10	2.5 x 1.0
ESD8011	Single Line (Tx, Rx)	0.10	X3DFN-2	0.62 x 0.32
ESD8101	Single Line (Tx, Rx)	0.20	DSN-2	0.43 x 0.23
ESD8111	Single Line (Tx, Rx)	0.20	WLCSP-2	0.6 x 0.3
ESD8472	Single Line (CC, SBU, D+/-)	0.20	X3DFN-2	0.62 x 0.32
ESD7471	Single Line (CC, SBU, D+/-)	0.24	XDFN-2 (SOD-882)	1.0 x 0.6

* Pending 1H16.

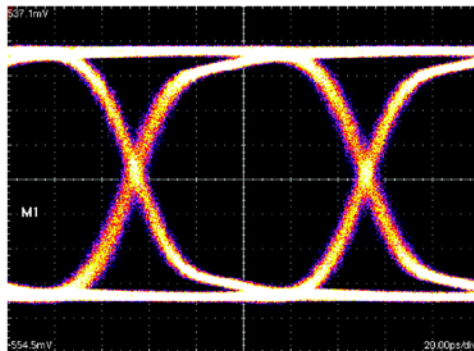

Without ESD

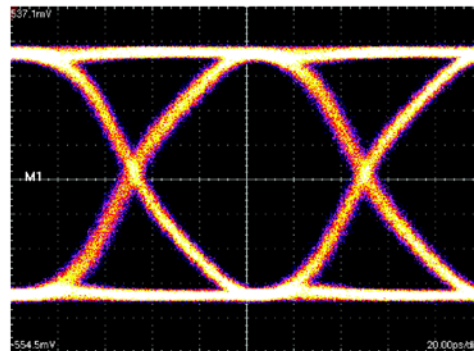

With ESD

USB3.1 Eye Diagram with and without ESD8704. 10 Gb/s

Energy Efficient Innovations

USB 2.0

One High Speed Pair, V_{CC}, Low Capacitance ESD Protection

Key Requirement

- Cap < 5 pF

Features

- 0.35 - 3.0 pF
- Multi-part solutions available
- Industry leading low clamping voltage

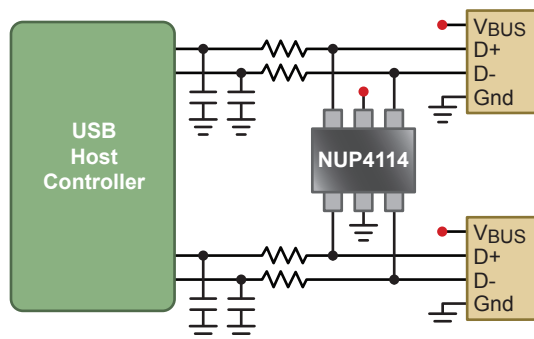
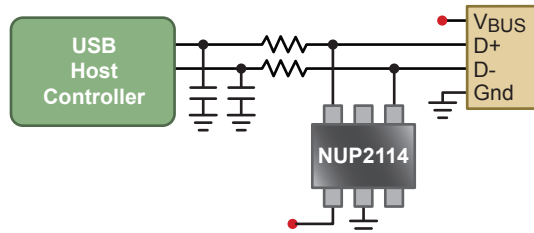
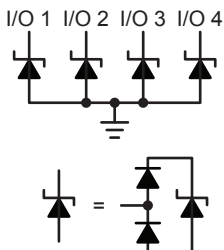

Device	Data Lines	Capacitance (pF)	Package	Size (mm)
NUP2114UPX	1 Pair (D+/-) + Vbus	0.8	SOT-553	1.2 x 1.6
NUP2114UCM	1 Pair (D+/-) + Vbus	0.8	TSOP-6	3.0 x 2.75
NUP4114UPX	2 Pair (D+/-) + Vbus	0.5	SOT-563	1.6 x 1.6
NUP4114UCL	2 Pair (D+/-) + Vbus	0.5	SC-88	2.0 x 2.1
NUP4114H	2 Pair (D+/-) + Vbus	0.5	TSOP-6	3.0 x 2.75
TVS4201MR6	2 Pair (D+/-) + Vbus	3	TSOP-6	3.0 x 2.75
ESD7L5.0	2	0.5	SOT-723	1.2 x 1.2
ESD8351MUT	1	0.37	X3DFN-2	0.6 x 0.3
ESD8351P2T	1	0.37	SOD-923	1.0 x 0.6
ESD9L5.0	1	0.5	SOD-923	1.0 x 0.6

One High Speed Pair, V_{CC}, Common Mode Filter + ESD Protection

Key Requirement

- Cap < 5 pF
- Common Mode Filtering

Features

- 0.5 - 0.8 pF
- Integrated EMI suppression with ESD protection
- Industry leading low clamping voltage

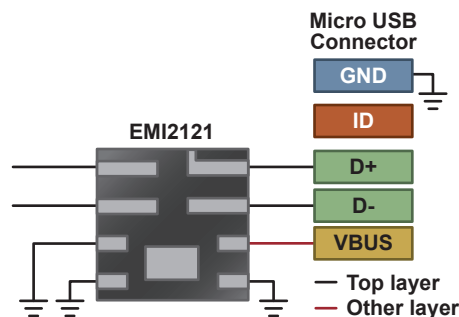
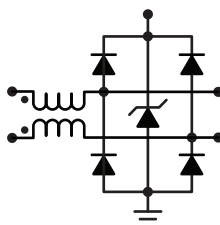

Device	Pairs	Capacitance @ 2.5 V (pF)	CM Attenuation @ 800 MHz (-dB)	DM Bandwidth F3dB (GHz)	Package	Size (mm)
EMI2121	1	0.9	-25	2.5	WQFN	2.2 x 2.0 x 0.75

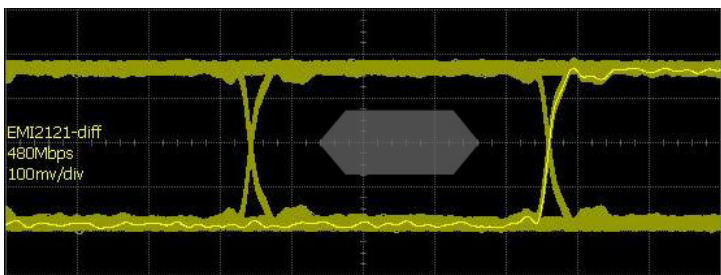

USB 2.0 @ 480 Mb/s

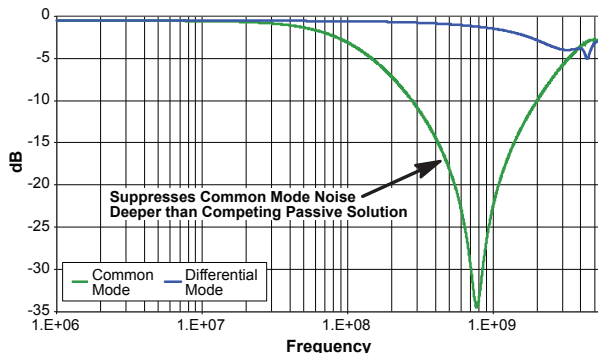

Thunderbolt

Four High Speed Pairs, up to Six Additional Lines, Low Capacitance ESD

Key Requirement

- Capacitance < 0.4 pF

Features

- Capacitance of 0.35 pF or lower
- Integrated solution in 2.0 x 1.2 mm package
- Grounds between pairs to reduce cross-talk
- Flow-through routing
- Industry leading clamping voltage

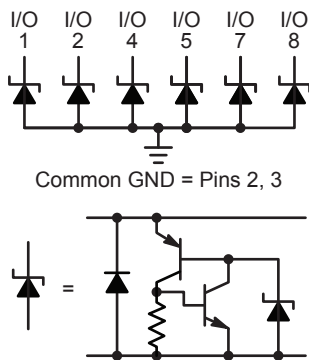

Device	Data Lines	Capacitance (pF)	Package	Size (mm)
ESD8006	3 Pair	0.25	UDFN-8	3.3 x 1.0
ESD8116	3 Pair	0.30	UDFN-8	2.0 x 1.2
ESD8011	Single Line	0.10	X3DFN-2	0.62 x 0.32
ESD8101	Single Line	0.20	DSN-2	0.43 x 0.23

Thunderbolt Connector Top Layer

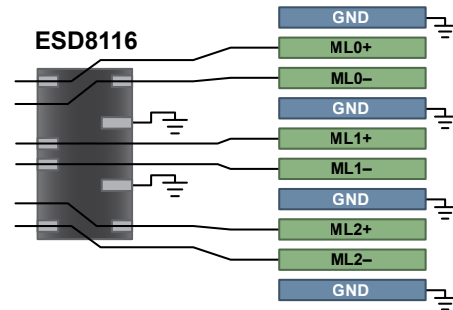

Thunderbolt Connector Bottom Layer

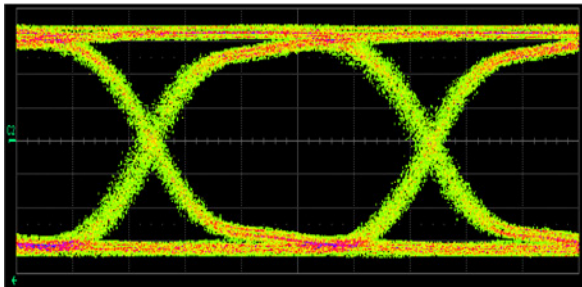
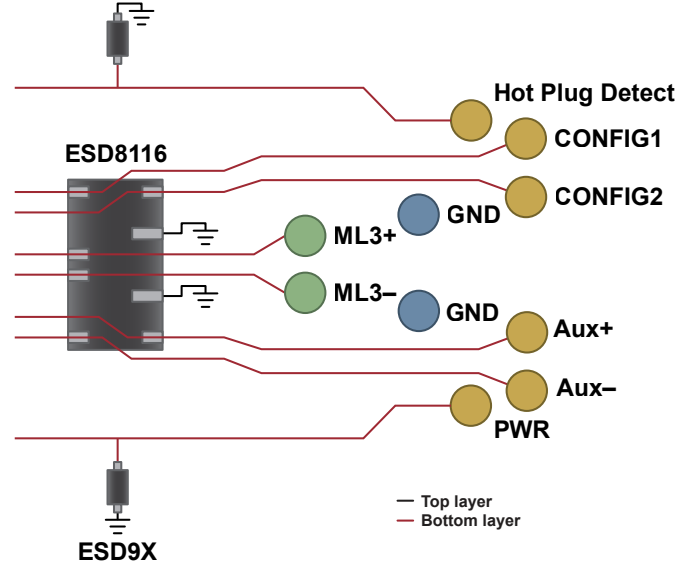

Without ESD8116

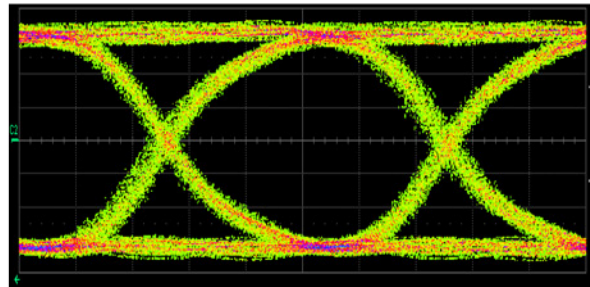

With ESD8116

Thunderbolt @ 10 Gb/s

Energy Efficient Innovations

HDMI, Display Port

Four High Speed Pairs, Up to Six Additional Interface Lines, Low Capacitance ESD

Key Requirement

- Cap < 0.5 pF

Features

- 0.3 pF ESD protection
- Flow through routing in high speed lines
- Industry leading low clamping voltage

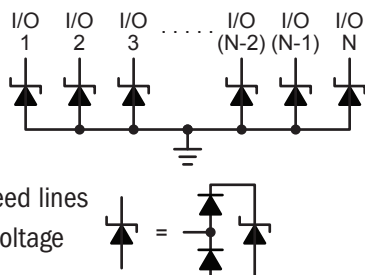

Device	Data Lines	Capacitance (pF)	Package	Size (mm)
ESD8104	4 (TMDS)	0.3	UDFN-10	2.5 x 1.0
ESD8118	8 (TMDS)	0.3	UDFN-10	3.2 x 1.2
ESD8040	14 (TMDS + Low Speed + Power)	0.3	UDFN-18	5.5 x 1.5
NUP4114UPX	5 (4 Low Speed + Power)	0.5	SOT-563	1.6 x 1.6
NUP4114UCL	5 (4 Low Speed + Power)	0.5	SC-88	2.0 x 2.1
NUP4114H	5 (4 Low Speed + Power)	0.5	TSOP-6	3.0 x 2.75

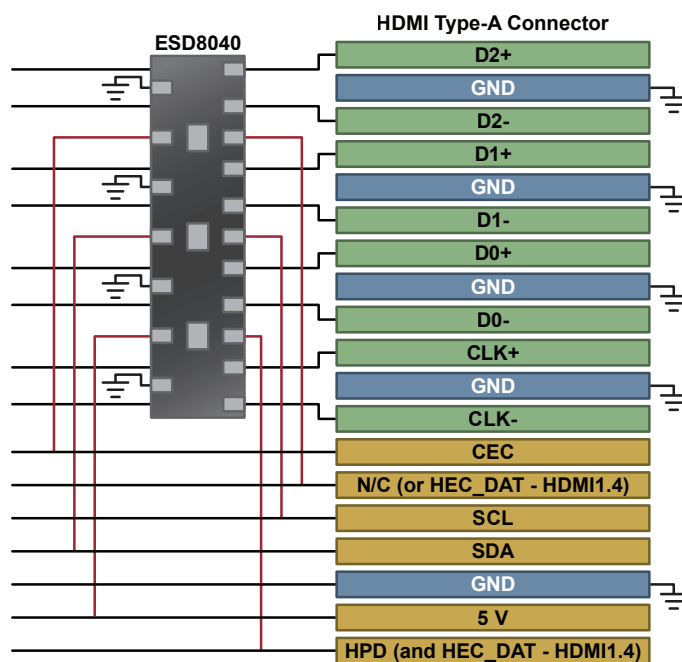
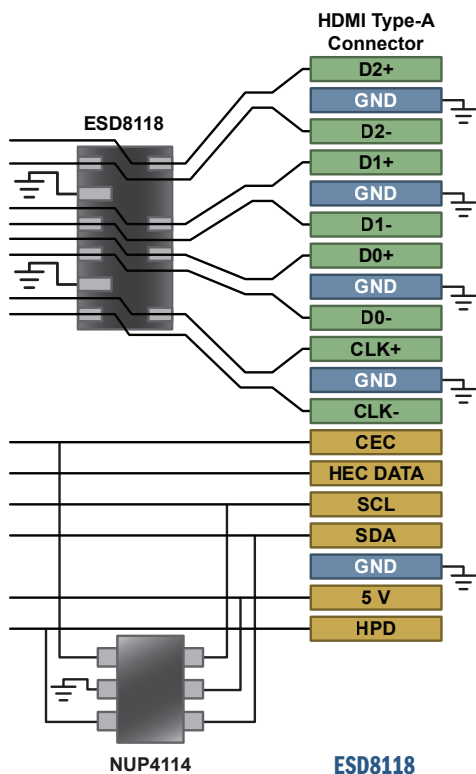

- MediaGuard fully integrated solution
 - Includes ethernet protection (HDMI1.4)
 - Backdrive current protection
- Top layer
— Other layer

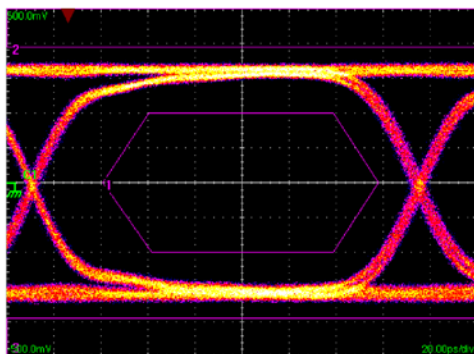

Without ESD

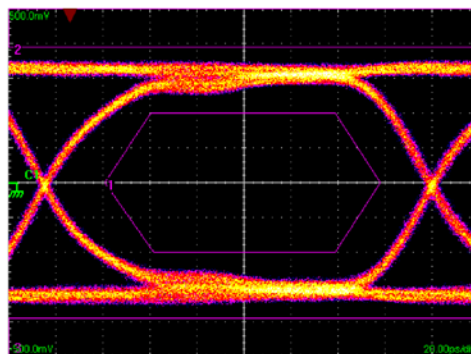

With ESD

HDMI 2.0 Eye Diagram with and without ESD8104. 6 Gb/s

Serial EEPROMs

Features

- Broad density range: 1 kb to 2 Mb
- Wide operating Vcc range: 1.8/1.7 V to 5.5 V
- High endurance: 1 million program/erase cycles
- Wide temperature range: industrial and extended

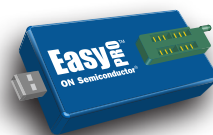

EasyPRO™ is a user-friendly, portable programming tool for ON Semiconductor serial EEPROMs (I²C, SPI, Microwire)

EEPROMs

Data Transmission Standard	Device	Density	Organization*	Vcc Min (V)	Vcc Max (V)	fCLK Max (MHz)	Package(s)
I ² C	CAT24M01	1 Mb	128k x 8	1.8	5.5	1	SOIC-8, TSSOP-8, UDFN-8
	CAT24C512	512 kb	64k x 8	1.8	5.5	1	SOIC-8, TSSOP-8, UDFN-8
	CAT24C256	256 kb	32k x 8	1.8	5.5	1	SOIC-8, TSSOP-8, UDFN-8
	CAT24C128	128 kb	16k x 8	1.8	5.5	1	SOIC-8, TSSOP-8, UDFN-8
	CAT24C64	64 kb	8k x 8	1.7	5.5	1	SOIC-8, TSSOP-8, UDFN-8, WLCSP-4
	CAT24C32	32 kb	4k x 8	1.7	5.5	1	SOIC-8, TSSOP-8, UDFN-8, WLCSP-4, WLCSP-5
	CAT24C16	16 kb	2k x 8	1.7	5.5	0.4	SOIC-8, TSSOP-8, UDFN-8, TSOT23-5, WLCSP-4, WLCSP-5
	CAT24C08	8 kb	1k x 8	1.7	5.5	0.4	SOIC-8, TSSOP-8, UDFN-8, TSOT23-5, WLCSP-4, WLCSP-5
	CAT24C04	4 kb	512 x 8	1.7	5.5	0.4	SOIC-8, TSSOP-8, UDFN-8, TSOT23-5, WLCSP-4, WLCSP-5
CAT24C02	2 kb	256 x 8	1.7	5.5	0.4	SOIC-8, TSSOP-8, UDFN-8, TSOT23-5, WLCSP-4, WLCSP-5	
SPI	CAT25M02	2 Mb	256k x 8	1.7	5.5	10	SOIC-8
	CAT25M01	1 Mb	128k x 8	1.8	5.5	10	SOIC-8, TSSOP-8
	CAT25512	512 kb	64k x 8	1.8	5.5	20	SOIC-8, TSSOP-8, UDFN-8
	CAT25256	256 kb	32k x 8	1.8	5.5	20	SOIC-8, TSSOP-8, UDFN-8
	CAT25128	128 kb	16k x 8	1.8	5.5	20	SOIC-8, TSSOP-8, UDFN-8
	CAT25640	64 kb	8k x 8	1.8	5.5	20	SOIC-8, TSSOP-8, UDFN-8
	CAT25320	32 kb	4k x 8	1.8	5.5	20	SOIC-8, TSSOP-8, UDFN-8
	CAT25160	16 kb	2k x 8	1.8	5.5	20	SOIC-8, TSSOP-8, UDFN-8
	CAT25080	8 kb	1k x 8	1.8	5.5	20	SOIC-8, TSSOP-8, UDFN-8
	CAT25040	4 kb	512 x 8	1.8	5.5	20	SOIC-8, TSSOP-8, UDFN-8
	CAT25020	2 kb	256 x 8	1.8	5.5	20	SOIC-8, TSSOP-8, UDFN-8
CAT25010	1 kb	128 x 8	1.8	5.5	20	SOIC-8, TSSOP-8, UDFN-8	
Microwire	CAT93C86	16 kb	2k x 8 / 1k x 16	1.8	5.5	3	SOIC-8
	CAT93C86B	16 kb	2k x 8 / 1k x 16	1.8 / 1.65	5.5	4	SOIC-8, TSSOP-8, UDFN-8
	CAT93C76	8 kb	1k x 8 / 512 x 16	1.8	5.5	3	SOIC-8, TSSOP-8
	CAT93C76B	8 kb	1k x 8 / 512 x 16	1.8 / 1.65	5.5	4	SOIC-8, TSSOP-8, UDFN-8
	CAT93C66	4 kb	512 x 8 / 256 x 16	1.8	5.5	2	SOIC-8, TSSOP-8
	CAT93C56	2 kb	256 x 8 / 128 x 16	1.8	5.5	2	SOIC-8, TSSOP-8
	CAT93C46	1 kb	128 x 8 / 64 x 16	1.8	5.5	2	SOIC-8, TSSOP-8
	CAT93C46B	1 kb	128 x 8 / 64 x 16	1.8 / 1.65	5.5	4	SOIC-8, TSSOP-8, UDFN-8

* Organization for Microwire devices is selectable.

Application Specific EEPROMs

Data Transmission Standard	Device	Density	Organization	Vcc Min (V)	Vcc Max (V)	fCLK Max (MHz)	Package(s)	Notes
I ² C	CAT24C208	8 kb	1024 x 8	2.5	5.5	0.4	SOIC-8	VESA™ dual-port serial EEPROM
I ² C	CAT34C04*	4 kb	512 x 8	1.7	5.5	1	UDFN-8	Serial Presence Detect (SPD) I2C EEPROM for DDR4 DIMM
I ² C/SMBus	CAT34TS04	4 kb	512 x 8	2.2	5.5	1	TDFN-8, UDFN-8	4 kb SPD EEPROM w/ Temperature Sensor for DDR4 DIMM
I ² C	CAT34C02	2 kb	256 x 8	1.7	5.5	0.4	UDFN-8, TDFN-8, TSSOP-8	Serial Presence Detect (SPD) I2C EEPROM for DDR3 DIMM
I ² C/SMBus	CAT34TS02	2 kb	256 x 8	3.0	3.6	0.4	TDFN-8, UDFN-8	2 kb SPD EEPROM w/ Temperature Sensor for DDR3 DIMM

* Pending 1H16.

Clock Synthesizers for High Performance Computing

Features

- Uses 25 MHz fundamental mode parallel resonant crystal
- PCI-e Gen 1,2 & 3 jitter compliant HCSL differential outputs
- NB3N50134 features configurable spread spectrum outputs
- NB3N51044 features individual OE control signal for each output, PLL bypass mode and an Input multiplexer
- NB3N51054 features I2C interface for OE control and configurable spread spectrum outputs
- 3.3 V supply

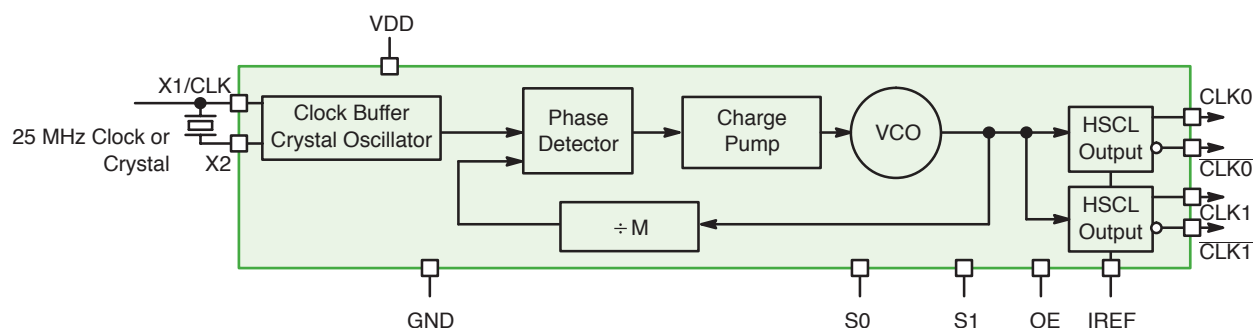

NB3N5573 Simplified Logic Diagram

Device	Number of Inputs	Input Type	f_{in} Typ (MHz)	Number of Outputs	Output Type	f_{out} Typ (MHz)	Spread Spectrum Outputs	Package
NB3N3002	1	Crystal; LVCMOS; LVTTTL	25	1	HCSL	25; 100; 125; 200	No	TSSOP-16
NB3N5573	1	Crystal; LVCMOS; LVTTTL	25	2	HCSL	25; 100; 125; 200	No	TSSOP-16
NB3N51032	1	Crystal; LVCMOS; LVTTTL	25	2	HCSL	25; 100; 125; 200	Yes	TSSOP-16
NB3N51034	1	Crystal; LVCMOS; LVTTTL	25	4	HCSL	100; 200	Yes	TSSOP-20
NB3N51044	2	Crystal; LVCMOS; LVTTTL	25	4	HCSL	100; 125	No	TSSOP-28
NB3N51054	1	Crystal; LVCMOS; LVTTTL	25	4	HCSL	100	Yes	TSSOP-24

Fanout Buffers for High Performance Computing

Features

- DC up to 400 MHz
- Accepts LVPECL, LVDS, HCSL, and single-ended inputs
- Typical input clock frequencies: 100, 133, 156.25, 166, 322.26, or 400 MHz
- Typical propagation delay: 800 ps
- HCSL differential outputs
- Integrated 50 Ω input termination resistors
- IREF pin enables setting of output drive
- Additive phase jitter 0.1 ps typical @ 100 MHz; PCI-e Gen 3 jitter compliant
- Additive phase jitter 80 fs maximum @ 156.25 MHz with NB3L208K, NB3L204K, NB3L202K; DB800H, DB400H, DB200H compliant

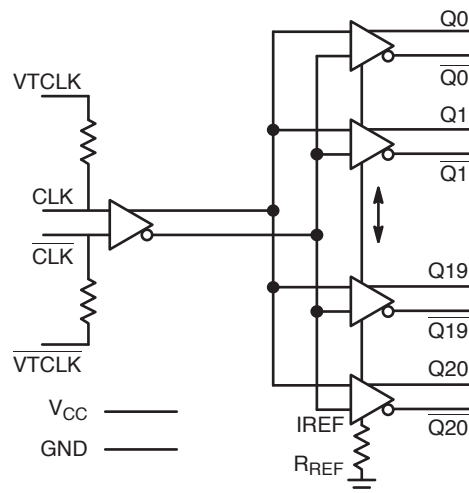

NB3N121K Logic Diagram

Device	Ratio	Additive $t_{\text{jitter(RMS) Typ}}$ (ps)	$t_{\text{skew(o-o) Max}}$ (ps)	$t_{\text{pd Typ}}$ (ns)	$t_{\text{r}} \& t_{\text{f Max}}$ (ps)	$f_{\text{maxClock Typ}}$ (MHz)	Package
NB3L202K*	1:2	0.046	30	1	125	350	QFN-16
NB3L204K*	1:4	0.046	30	1	125	350	QFN-24
NB3N106K	1:6	0.1	100	0.8	400	400	QFN-24
NB3L208K	1:8	0.046	30	1	125	350	QFN-32
NB3N108K	1:8	0.1	100	0.8	400	400	QFN-32
NB3N111K	1:10	0.1	100	0.8	400	400	QFN-32
NB4N111K	1:10	<1	100	0.8	700	400	QFN-32
NB3N121K	1:21	0.1	100	0.8	700	400	QFN-52
NB4N121K	1:21	<1	50	0.8	700	200	QFN-52

* Pending 1H16.

Computing Clock for Graphics

P1P8160A Features

- Provides reference clock to the GPU & reduces EMI in the GDDR interface
- Input frequency 27 MHz; crystal or reference clock
- Output frequency 100 MHz spread spectrum clock; 27 MHz RefOUT
- Two tri-level logic pins for selecting eight frequency deviations along with SSOFF
- Modulation rate at 100 MHz: 32 kHz
- Low cycle-cycle & long term jitter
- Supply voltage: 3.3 V \pm 10%
- WDFN-10 package

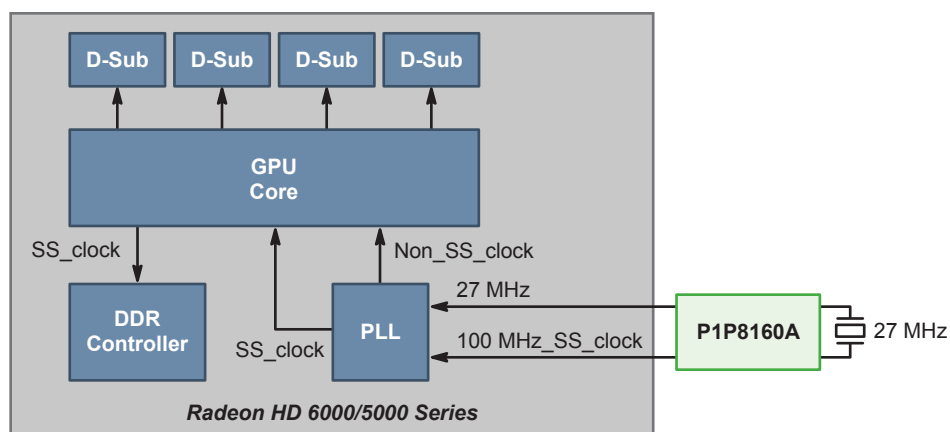

P1P8160A for AMD Graphics Card Application

Zero Delay Buffers Compliant with DB Specifications

Features

- Differential SRC clock support
- NB3N1900K, NB3N1200K: DB1900Z and DB1200Z compliant with 19 and 12 output pairs respectively
- NB3W1200L, NB3W800L: DB1200ZL and DB800ZL compliant with 12 and 8 low power NMOS push-pull output pairs respectively
- NB3W1900L: 19 low power NMOS push-pull output pairs
- Optimized for 100 MHz and 133 MHz to meet PCIe* Gen 2/Gen 3 and Intel QPI phase jitter specifications
- Spread spectrum compatible for low EMI
- Pseudo-external fixed-feedback for low input-to-output delay variation
- Individual OE control pin for each output
- SMBUS programmability for power down mode, PLL BW modes, PLL/Bypass mode & frequency selection

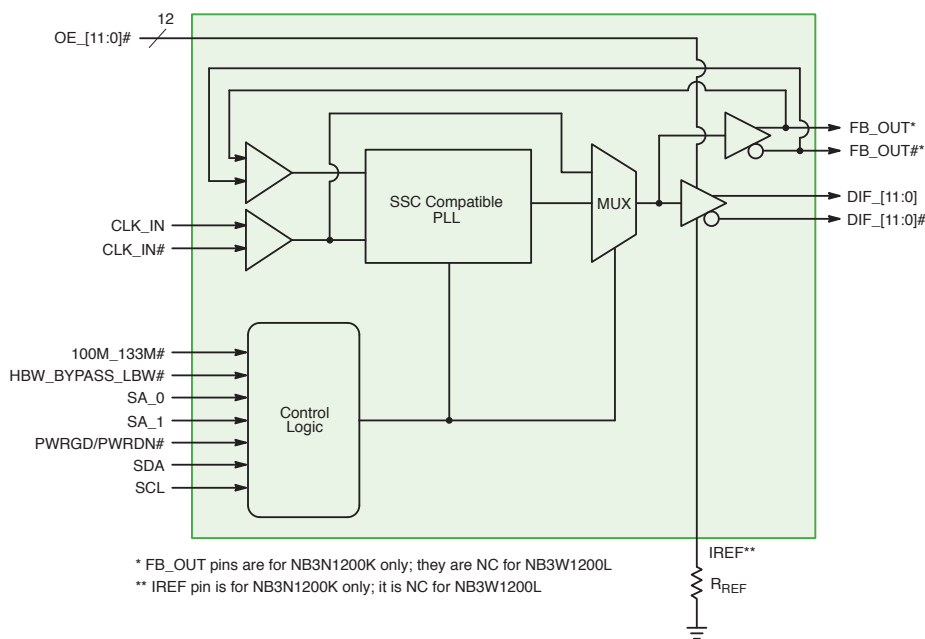

NB3N1200K Simplified Block Diagram

Device	Ratio	Output	t _{jitter(Cy-Cy)} Typ (ps)	t _{skew(I-o)} Max (ps)	t _{skew(o-o)} Max (ps)	Edge Rate Max (V/ns)	Package
NB3W800L	1:8	Low power NMOS push-pull	34	±100	50	4	QFN-48
NB3N1200K	1:12	HCSL	50	±100	50	4	QFN-64
NB3W1200L	1:12	Low power NMOS push-pull	50	±100	50	4	QFN-64
NB3N1900K	1:19	HCSL	50	±100	65	4	QFN-72
NB3W1900L	1:19	HCSL	50	±100	85	4	QFN-72

Sales and Design Assistance from ON Semiconductor

ON Semiconductor Technical Support
www.onsemi.com/support

ON SEMICONDUCTOR INTERNATIONAL SALES OFFICES		
GREATER CHINA	Beijing	86-10-8577-8200
	Hong Kong	852-2689-0088
	Shenzhen	86-755-8209-1128
	Shanghai	86-21-5131-7168
	Taipei, Taiwan	886-2-2377-9911
FRANCE	Paris	33 (0)1 39-26-41-00
GERMANY	Munich	49 (0) 89-93-0808-0
INDIA	Bangalore	91-98-808-86706
ISRAEL	Raanana	972 (0) 9-9609-111
ITALY	Milan	39 02 9239311
JAPAN	Tokyo	81-3-5427-3055
KOREA	Seoul	82-31-786-3700
MALAYSIA	Penang	60-4-6463877
SINGAPORE	Singapore	65-6484-8603
SLOVAKIA	Piestany	421 33 790 2450
UNITED KINGDOM	Maidenhead	44 (0) 1628 244326

For a comprehensive listing of
**ON Semiconductor Sales Offices, Distributors,
 and Rep Firms, please visit:**

Americas & EMEA: www.onsemi.com/sales

China: www.onsemi.cn/sales

Japan: www.onsemi.jp/sales



ON Semiconductor Distribution Partners

Allied Electronics	www.alliedelec.com	(800) 433-5700
Altima Corp.	www.altima.co.jp	(81) 45 476 2155
Arrow Electronics	www.arrow.com	(800) 777-2776
Avnet	www.em.avnet.com	(800) 332-8638
Chip One Stop, Inc.	www.chip1stop.com/maker/on	(81) 45 470 8771
Daiwa Distribution Ltd.	www.daiwahk.com	(852) 2341 3351
Digi-Key	www.digkey.com	(800) 344-4539
EBV Elektronik	www.ebv.com/en/locations.html	(49) 8121 774-0
Future & FAI Electronics	www.futureelectronics.com/contact	1-800-FUTURE1 (388-8731)
Mouser Electronics	www.mouser.com	(800) 346-6873
Newark/Farnell	www.farnell.com/onsemi	(800) 4-NEWARK
OS Electronics Co., Ltd.	www.oselec.jp	Japanese: (81) 3 3255 5985 Other Languages: (81) 3 3255 6066
Promate Electronic Co.	www.promate.com.tw	(886) 2 2659 0303
RinnoVent Co., Ltd. (Ryosan Group)	www.ryosan.co.jp	(81) 3 3862 2440
RS Components	www.rs-components.com	(44) 153 644 4414
Segyung Bristestone Co.	www.bristestone.com	(82) 2 3218 1511
Serial Microelectronics, HK	www.serialsys.com.hk	(852) 2790 8220
World Peace Industries Co.	www.wpi-group.com	(852) 2365 4860
WT Microelectronics Co.	www.wtmec.com	(852) 2950 0820
Yosun Electronics	www.yosun.com.tw	(886) 2 2659 8168

AMERICAS REP FIRMS

Alabama	Huntsville	e-Components	(256) 533-2444
Brazil	Countrywide	Ammon & Rizos	(+55) 11-4688-1960
California	Bay Area	Electec	(408) 496-0706
	Southern California	Tech Coast Sales	(949) 305-6869
Canada	Eastern Canada	Astec	(905) 607-1444
Connecticut	Statewide	Paragon Electronic Systems	(603) 645-7630
Florida	Statewide	e-Components	(888) 468-2444
Georgia	Atlanta	e-Components	(888) 468-2444
Illinois	Statewide	Matrix - Design Technology	(952) 400-1070
Indiana	Fishers	Bear VAI	(317) 570-0707
Iowa	Statewide	Matrix - Design Technology	(319) 362-6824
Maine	Statewide	Paragon Electronic Systems	(603) 645-7630
Maryland	Columbia	Mechtronics Sales	(410) 309-9600
Massachusetts	Statewide	Paragon Electronic Systems	(603) 645-7630
	Countrywide	Ammon & Rizos	(+55) 11-4688-1960
Michigan	St. Joseph	Bear VAI	(440) 526-1991
Minnesota	Eden Prairie	Matrix - Design Technology	(952) 400-1070
Missouri	Belton	Matrix - Design Technology	(816) 589-2308
Nebraska	Statewide	Matrix - Design Technology	(816) 589-2308
New Hampshire	Statewide	Paragon Electronic Systems	(603) 645-7630
New Jersey	Statewide	S.J. Metro	(516) 942-3232
New York	Binghamton	TriTech - Full Line Rep	(607) 722-3580
	Jericho	S.J. Metro	(516) 942-3232
	Rochester	TriTech - Full Line Rep	(585) 385-6500
North Carolina	Raleigh	e-Components	(888) 468-2444
North Dakota	Statewide	Matrix - Design Technology	(952) 400-1070
Ohio	Brecksville	Bear VAI Technology	(440) 526-1991
Puerto Rico	Countrywide	e-Components	(888) 468-2444
Rhode Island	Statewide	Paragon Electronic Systems	(603) 645-7630
South Dakota	Statewide	Matrix - Design Technology	(952) 400-1070
Vermont	Statewide	Paragon Electronic Systems	(603) 645-7630
Wisconsin	Statewide	Matrix - Design Technology	(952) 400-1070

ARM and Cortex are registered trademarks of ARM Limited (or its subsidiaries) in the EU and/or elsewhere. All other brand names and product names appearing in this document are trademarks of their respective holders.

ON Semiconductor and the ON logo are registered trademarks of Semiconductor Components Industries, LLC (SCILLC) or its subsidiaries in the United States and/or other countries. SCILLC owns the rights to a number of patents, trademarks, copyrights, trade secrets, and other intellectual property. A listing of SCILLC's product/patent coverage may be accessed at www.onsemi.com/site/pdf/Patent-Marking.pdf. SCILLC reserves the right to make changes without further notice to any products herein. SCILLC makes no warranty, representation or guarantee regarding the suitability of its products for any particular purpose, nor does SCILLC assume any liability arising out of the application or use of any product or circuit, and specifically disclaims any and all liability, including without limitation special, consequential or incidental damages. "Typical" parameters which may be provided in SCILLC data sheets and/or specifications can and do vary in different applications and actual performance may vary over time. All operating parameters, including "Typicals" must be validated for each customer application by customer's technical experts. SCILLC does not convey any license under its patent rights nor the rights of others. SCILLC products are not designed, intended, or authorized for use as components in systems intended for surgical implant into the body, or other applications intended to support or sustain life, or for any other application in which the failure of the SCILLC product could create a situation where personal injury or death may occur. Should Buyer purchase or use SCILLC products for any such unintended or unauthorized application, Buyer shall indemnify and hold SCILLC and its officers, employees, subsidiaries, affiliates, and distributors harmless against all claims, costs, damages, and expenses, and reasonable attorney fees arising out of, directly or indirectly, any claim of personal injury or death associated with such unintended or unauthorized use, even if such claim alleges that SCILLC was negligent regarding the design or manufacture of the part. SCILLC is an Equal Opportunity/Affirmative Action Employer. This literature is subject to all applicable copyright laws and is not for resale in any manner.

PUBLICATION ORDERING INFORMATION

LITERATURE FULFILLMENT:

Literature Distribution Center for ON Semiconductor
 19521 E. 32nd Pkwy, Aurora, Colorado 80011 USA
Phone: 303-675-2175 or 800-344-3860 Toll Free USA/Canada
Fax: 303-675-2176 or 800-344-3867 Toll Free USA/Canada
Email: orderlit@onsemi.com

N. American Technical Support: 800-282-9855 Toll Free
 USA/Canada.

Europe, Middle East and Africa Technical Support:
 Phone: 421 33 790 2910

Japan Customer Focus Center
 Phone: 81-3-5817-1050

ON Semiconductor Website: www.onsemi.com

Order Literature: <http://www.onsemi.com/orderlit>

For additional information, please contact your local
 Sales Representative

Mouser Electronics

Authorized Distributor

Click to View Pricing, Inventory, Delivery & Lifecycle Information:

[ON Semiconductor:](#)

[NCP81102MNTXG](#)



Компания «ЭлектроПласт» предлагает заключение долгосрочных отношений при поставках импортных электронных компонентов на взаимовыгодных условиях!

Наши преимущества:

- Оперативные поставки широкого спектра электронных компонентов отечественного и импортного производства напрямую от производителей и с крупнейших мировых складов;
- Поставка более 17-ти миллионов наименований электронных компонентов;
- Поставка сложных, дефицитных, либо снятых с производства позиций;
- Оперативные сроки поставки под заказ (от 5 рабочих дней);
- Экспресс доставка в любую точку России;
- Техническая поддержка проекта, помощь в подборе аналогов, поставка прототипов;
- Система менеджмента качества сертифицирована по Международному стандарту ISO 9001;
- Лицензия ФСБ на осуществление работ с использованием сведений, составляющих государственную тайну;
- Поставка специализированных компонентов (Xilinx, Altera, Analog Devices, Intersil, Interpoint, Microsemi, Aeroflex, Peregrine, Syfer, Eurofarad, Texas Instrument, Miteq, Cobham, E2V, MA-COM, Hittite, Mini-Circuits, General Dynamics и др.);

Помимо этого, одним из направлений компании «ЭлектроПласт» является направление «Источники питания». Мы предлагаем Вам помощь Конструкторского отдела:

- Подбор оптимального решения, техническое обоснование при выборе компонента;
- Подбор аналогов;
- Консультации по применению компонента;
- Поставка образцов и прототипов;
- Техническая поддержка проекта;
- Защита от снятия компонента с производства.



Как с нами связаться

Телефон: 8 (812) 309 58 32 (многоканальный)

Факс: 8 (812) 320-02-42

Электронная почта: org@eplast1.ru

Адрес: 198099, г. Санкт-Петербург, ул. Калинина, дом 2, корпус 4, литера А.