

Super I/O with Temperature Sensing, Quiet Auto Fan and Glue Logic with PECL

PRODUCT FEATURES

Data Brief

- **General Features**
 - 3.3 Volt Operation (SIO Block is 5 Volt Tolerant)
 - LPC Interface
 - Programmable Wake-up Event Interface
 - PC99, PC2001 Compliant
 - ACPI 2.0 Compliant
 - Multiplexed Command, Address and Data Bus
 - Serial IRQ Interface Compatible with Serialized IRQ Support for PCI Systems
 - PME Interface
 - ISA Plug-and-Play Compatible Register Set
 - 25 General Purpose Input/Output Pins
 - System Management Interrupt
- **AC Power Failure Recovery**
- **Watchdog Timer**
- **2.88 MB Super I/O Floppy Disk Controller**
 - Licensed CMOS 765B Floppy Disk Controller
 - Software and Register Compatible with SMSC's Proprietary 82077AA Compatible Core
 - Supports One Floppy Drive
 - Configurable Open Drain/Push-Pull/Output Drivers
 - Supports Vertical Recording Format
 - 16-Byte Data FIFO
 - 100% IBM® Compatibility
 - Detects All Overrun and Underrun Conditions
 - Sophisticated Power Control Circuitry (PCC) Including Multiple Powerdown Modes for Reduced Power Consumption
 - DMA Enable Logic
 - Data Rate and Drive Control Registers
 - 480 Address, Up to Eight IRQ and Three DMA Options
 - Support 3 Mode FDD
 - Enhanced Digital Data Separator
 - 2 Mbps, 1 Mbps, 500 Kbps, 300 Kbps, 250 Kbps Data Rates
 - Programmable Precompensation Modes
- **Serial Ports**
 - Two Full Function Serial Ports
 - High Speed NS16C550A Compatible UARTs with Send/Receive 16-Byte FIFOs
 - Supports 230k and 460k Baud
 - Programmable Baud Rate Generator
 - Modem Control Circuitry
 - 480 Address and 15 IRQ Options
- **Infrared Port**
 - Multiprotocol Infrared Interface
 - IrDA 1.0 Compliant
 - SHARP ASK IR
 - 480 Addresses, Up to 15 IRQ
- **Multi-Mode™ Parallel Port with ChiProtect™**
 - Standard Mode IBM PC/XT®, PC/AT®, and PS/2™ Compatible Bi-directional Parallel Port
 - Enhanced Parallel Port (EPP) Compatible - EPP 1.7 and EPP 1.9 (IEEE 1284 Compliant)
 - IEEE 1284 Compliant Enhanced Capabilities Port (ECP)
 - ChiProtect Circuitry for Protection
 - 960 Address, Up to 15 IRQ and Three DMA Options
- **Keyboard Controller**
 - 8042 Software Compatible
 - 8 Bit Microcomputer
 - 2k Bytes of Program ROM
 - 256 Bytes of Data RAM
 - Four Open Drain Outputs Dedicated for Keyboard/Mouse Interface
 - Asynchronous Access to Two Data Registers and One Status Register
 - Supports Interrupt and Polling Access
 - 8 Bit Counter Timer
 - Port 92 Support
 - Fast Gate A20 and KRESET Outputs
- **Motherboard GLUE Logic**
 - IDE Reset Output
 - (4) Buffered PCI Reset Outputs with software controlled reset capability - default transparent
 - Front Panel Reset Debouncing and Power Good Signal Generation
 - Power Supply Turn On Circuitry with Support for power button on PS/2 Keyboard
 - Resume Reset Signal Generation
 - SMBus Isolation Circuitry (2 sets external and 1 set internal for Hardware Monitoring Block)
 - SMBus 2.0 compliant interface for Hardware Monitoring
 - LED Control (2)
- **Fan Control**
 - 5 PWM (Pulse width Modulation) Outputs
 - Two and three piece linear fan function options
 - Low frequency and high frequency PWM support
 - 6 Fan Tachometer Inputs
 - Programmable automatic fan control based on temperature
 - Interrupt Pin for out-of-limit Fantach Events
 - Fantach events generate PMEs



- Temperature Monitor
 - Monitoring of Two Remote Thermal Diodes
 - Processor temperature monitoring by PECI
 - Internal Ambient Temperature Measurement
 - Limit Comparison of all Monitored Values
 - Interrupt Pin for out-of-limit Temperature Indication
 - Thermal events generate PMEs
 - Configurable offset for internal or external temperature channels.
- Voltage Monitor
 - Monitor Power supplies (2 at 1.125V, one at 5V, one each for Vccp, Vbat, VTR, and VCC)
 - Limit Comparison of all Monitored Values
 - Interrupt Pin for out-of-limit Voltage Indication
 - Voltage events generate PMEs
- Security Features
 - Security Key Register (32 byte) for Device Authentication
- 3 VID (Voltage Identification) Inputs
- Phoenix Keyboard BIOS ROM
- 128 Pin QFP Lead-Free RoHS Compliant Package

ORDER NUMBER(S):

SCH5027D-NW for 128 pin, QFP Lead-Free RoHS Compliant Package



80 ARKAY DRIVE, HAUPPAUGE, NY 11788 (631) 435-6000, FAX (631) 273-3123

Copyright © 2007 SMSC or its subsidiaries. All rights reserved.

Circuit diagrams and other information relating to SMSC products are included as a means of illustrating typical applications. Consequently, complete information sufficient for construction purposes is not necessarily given. Although the information has been checked and is believed to be accurate, no responsibility is assumed for inaccuracies. SMSC reserves the right to make changes to specifications and product descriptions at any time without notice. Contact your local SMSC sales office to obtain the latest specifications before placing your product order. The provision of this information does not convey to the purchaser of the described semiconductor devices any licenses under any patent rights or other intellectual property rights of SMSC or others. All sales are expressly conditional on your agreement to the terms and conditions of the most recently dated version of SMSC's standard Terms of Sale Agreement dated before the date of your order (the "Terms of Sale Agreement"). The product may contain design defects or errors known as anomalies which may cause the product's functions to deviate from published specifications. Anomaly sheets are available upon request. SMSC products are not designed, intended, authorized or warranted for use in any life support or other application where product failure could cause or contribute to personal injury or severe property damage. Any and all such uses without prior written approval of an Officer of SMSC and further testing and/or modification will be fully at the risk of the customer. Copies of this document or other SMSC literature, as well as the Terms of Sale Agreement, may be obtained by visiting SMSC's website at <http://www.smisc.com>. SMSC is a registered trademark of Standard Microsystems Corporation ("SMSC"). Product names and company names are the trademarks of their respective holders.

SMSC DISCLAIMS AND EXCLUDES ANY AND ALL WARRANTIES, INCLUDING WITHOUT LIMITATION ANY AND ALL IMPLIED WARRANTIES OF MERCHANTABILITY, FITNESS FOR A PARTICULAR PURPOSE, TITLE, AND AGAINST INFRINGEMENT AND THE LIKE, AND ANY AND ALL WARRANTIES ARISING FROM ANY COURSE OF DEALING OR USAGE OF TRADE. IN NO EVENT SHALL SMSC BE LIABLE FOR ANY DIRECT, INCIDENTAL, INDIRECT, SPECIAL, PUNITIVE, OR CONSEQUENTIAL DAMAGES; OR FOR LOST DATA, PROFITS, SAVINGS OR REVENUES OF ANY KIND; REGARDLESS OF THE FORM OF ACTION, WHETHER BASED ON CONTRACT; TORT; NEGLIGENCE OF SMSC OR OTHERS; STRICT LIABILITY; BREACH OF WARRANTY; OR OTHERWISE; WHETHER OR NOT ANY REMEDY OF BUYER IS HELD TO HAVE FAILED OF ITS ESSENTIAL PURPOSE, AND WHETHER OR NOT SMSC HAS BEEN ADVISED OF THE POSSIBILITY OF SUCH DAMAGES.

General Description

The SCH5027D-NW is a 3.3V (Super I/O Block is 5V tolerant) PC99/PC2001 compliant Super I/O controller with an LPC interface. SCH5027D-NW also includes Hardware Monitoring capabilities, enhanced Security features, Power Control logic and Motherboard Glue logic.

The SCH5027D-NW's hardware monitoring capability includes temperature, voltage and fan speed monitoring. It has the ability to alert the system to out-of-limit conditions and automatically control the speeds of multiple fans. There are four analog inputs for monitoring external voltages, two at 1.125V, one at 5V and one at 2.25V for V_{ccp} (core processor voltage). There is also internal monitoring of the SIO's VCC, VTR, and Vbat power supplies. The SCH5027D-NW includes support for monitoring two external temperatures via thermal diode inputs and an internal sensor for measuring ambient temperature. The nHWM_INT pin is implemented to indicate out-of-limit temperature, voltage, and FANTACH conditions. The hardware monitoring block of the SCH5027D-NW is accessible via the System Management Bus (SMBus). The same interrupt event reported on the nHWM_INT pin also creates PME wakeup events and speaker alarm annunciation.

The SCH5027D-NW also allows for a two or three piece linear fan function.

The Motherboard Glue logic includes various power management and system logic including generation of nRSMRST, SMBus buffers, and buffered PCI reset outputs.

The SCH5027D-NW incorporates complete legacy Super I/O functionality including an 8042 based keyboard and mouse controller, an IEEE 1284, EPP, and ECP compatible parallel port, one serial port that is 16C550A UART compatible, one IrDA 1.0 infrared ports, and a floppy disk controller with SMSC's true CMOS 765B core and enhanced digital data separator. The true CMOS 765B core provides 100% compatibility with IBM PC/XT and PC/AT architectures and is software and register compatible with SMSC's proprietary 82077AA core. System related functionality, which offers flexibility to the system designer, General Purpose I/O control functions, control of two LED's, and fan control using fan tachometer inputs and pulse width modulator (PWM) outputs

The SCH5027D-NW is ACPI 1.0/2.0 compatible and therefore supports multiple low power-down modes. It incorporates sophisticated power control circuitry (PCC), which includes support for keyboard and mouse wake-up events.

The SCH5027D-NW supports the ISA Plug-and-Play Standard register set (Version 1.0a). The I/O Address, DMA Channel and hardware IRQ of each logical device in the SCH5027D-NW may be reprogrammed through the internal configuration registers. There are up to 480 (960 - Parallel Port) I/O address location options, a Serialized IRQ interface, and Three DMA channels.

Block Diagram

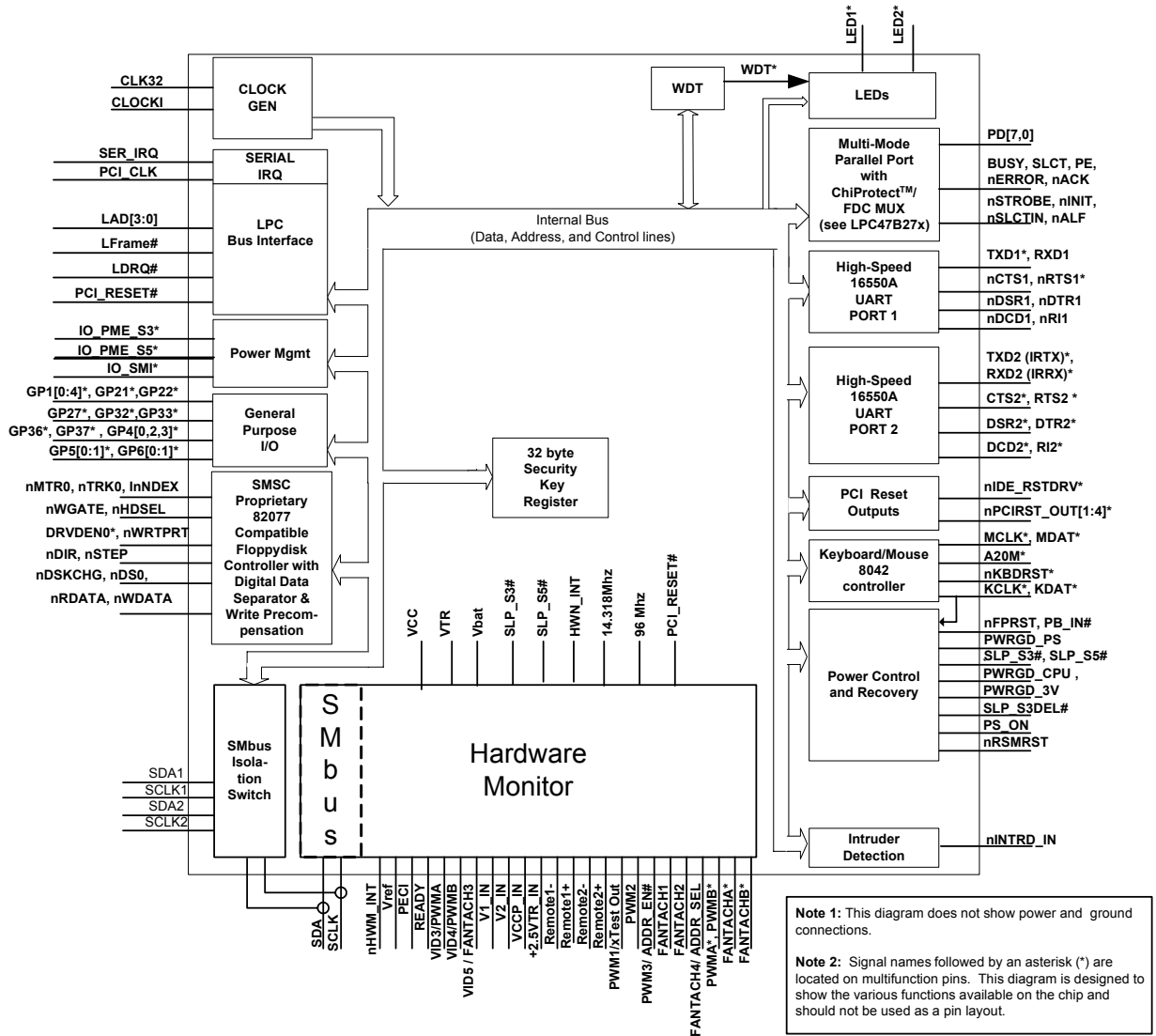

Figure 1 SCH5027D-NW Block Diagram

Package Outline

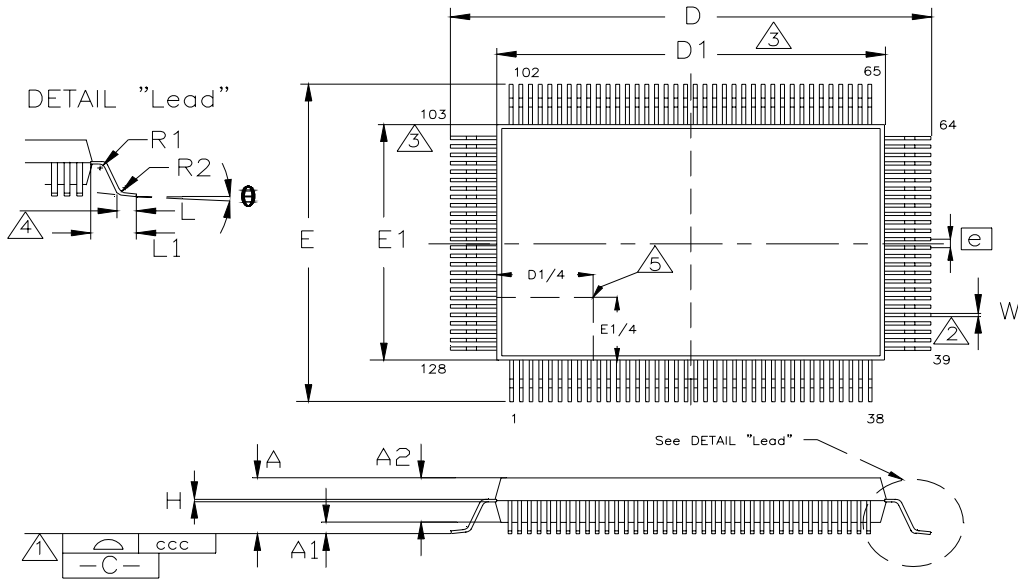

Figure 2 128 Pin QFP Package Outline, 14X20X2.7 Body, 3.2 mm Footprint.

Table 1 128 Pin QFP Package Parameters

	MIN	NOMINAL	MAX	REMARKS
A	~	~	3.4	Overall Package Height
A1	0.05	~	0.5	Standoff
A2	2.55	~	3.05	Body Thickness
D	23.00	23.20	23.40	X Span
D1	19.90	20.00	20.10	X body Size
E	17.00	17.20	17.40	Y Span
E1	13.90	14.00	14.10	Y body Size
H	0.09	~	0.20	Lead Frame Thickness
L	0.73	0.88	1.03	Lead Foot Length
L1	~	1.60	~	Lead Length
e	0.50 Basic			Lead Pitch
q	0°	~	7°	Lead Foot Angle
W	0.10	~	0.30	Lead Width
R1	0.08	~	~	Lead Shoulder Radius
R2	0.08	~	0.30	Lead Foot Radius
ccc	~	~	0.08	Coplanarity

Notes:

1. Controlling Unit: millimeter.
2. Controlling Unit: millimeter.
3. Tolerance on the position of the leads is ± 0.04 mm maximum.
4. Package body dimensions D1 and E1 do not include the mold protrusion.
5. Maximum mold protrusion is 0.25 mm.
6. Dimension for foot length L measured at the gauge plane 0.25 mm above the seating plane.
7. Details of pin 1 identifier are optional but must be located within the zone indicated.



Компания «ЭлектроПласт» предлагает заключение долгосрочных отношений при поставках импортных электронных компонентов на взаимовыгодных условиях!

Наши преимущества:

- Оперативные поставки широкого спектра электронных компонентов отечественного и импортного производства напрямую от производителей и с крупнейших мировых складов;
- Поставка более 17-ти миллионов наименований электронных компонентов;
- Поставка сложных, дефицитных, либо снятых с производства позиций;
- Оперативные сроки поставки под заказ (от 5 рабочих дней);
- Экспресс доставка в любую точку России;
- Техническая поддержка проекта, помощь в подборе аналогов, поставка прототипов;
- Система менеджмента качества сертифицирована по Международному стандарту ISO 9001;
- Лицензия ФСБ на осуществление работ с использованием сведений, составляющих государственную тайну;
- Поставка специализированных компонентов (Xilinx, Altera, Analog Devices, Intersil, Interpoint, Microsemi, Aeroflex, Peregrine, Syfer, Eurofarad, Texas Instrument, Miteq, Cobham, E2V, MA-COM, Hittite, Mini-Circuits, General Dynamics и др.);

Помимо этого, одним из направлений компании «ЭлектроПласт» является направление «Источники питания». Мы предлагаем Вам помощь Конструкторского отдела:

- Подбор оптимального решения, техническое обоснование при выборе компонента;
- Подбор аналогов;
- Консультации по применению компонента;
- Поставка образцов и прототипов;
- Техническая поддержка проекта;
- Защита от снятия компонента с производства.



Как с нами связаться

Телефон: 8 (812) 309 58 32 (многоканальный)

Факс: 8 (812) 320-02-42

Электронная почта: org@eplast1.ru

Адрес: 198099, г. Санкт-Петербург, ул. Калинина, дом 2, корпус 4, литера А.