

# EMOSAFE EN-65

Product Datasheet

Installation Network Isolators with Integrated Cable



*EN-65S isolators with Z-4-SF-EXT and with Z-3-SF-INT, and EN-65K*

## 1 FEATURES AND ADVANTAGES

- Available with Keystone or SnapFit interface
- SnapFit accessories available for panel mounting
- 5.0 kV AC dielectric strength
- 8.5 kV DC dielectric strength
- Suitable for installation into devices and racks
- Suitable for use within medical supply units
- Designed and tested to meet IEC 60601-1
- UL Recognized Component
- High Performance Gigabit Ethernet
- ISO 11801 Class D Ethernet Performance attainable in Permanent Links which include the isolator
- Extremely low insertion losses; thereby total cable lengths of 100 metres are achievable
- 100% inspection by our Quality Control
- Available in various cable stub lengths
- Additional transient voltage suppression on signal lines
- Suitable for devices with supply voltages up to 400 V AC
- RoHS compliant

## 2 GENERAL DESCRIPTION

The EMOSAFE EN-65 Network Isolator disconnects every electrically conducting connection (specifically the data and shield conductors) between devices connected together via a copper-based Ethernet network. The Network Isolator prevents current flow resulting from differences in electrical potentials, and

also protects connected devices and their users from stray external voltages and power surges which may be directly or inductively coupled onto the network lines by causes such as installation errors, lightning, switching operations, and electrostatic discharge.

Built into a medical electrical (ME) product, the EMOSAFE EN-65 Network Isolator facilitates the safe Ethernet connection of this ME product within the patient environment. The EN-65 satisfies all construction requirements of IEC 60601-1 in the formation of two means of patient protection (MOPP) within the network interface, thereby practically eliminating the risk of electrical shocks arising from such stray external voltages at the network connection. With its UL approval, the EN-65 is also suitable for devices destined for export to the North American markets.

The EN-65 is equipped with transient voltage suppression (TVS) diode circuitry. While conventional network isolators can only block voltage spikes that occur simultaneously at all signal lines (arising, for example, from potential voltage differences), potentially dangerous or damaging differential voltages on individual signal lines are clipped by the TVS circuitry, preventing these voltages from reaching Ethernet devices, operators, and patients. Such differential voltage spikes can be caused, for example, by malfunctioning devices connected to the Ethernet, or also by electrostatic discharge events during the plugging processes.

The EMOSAFE EN-65 is an efficient and compact gigabit Ethernet network isolator, characterised by exceptional Ethernet performance and a very high dielectric withstanding voltage. As a Keystone module, it can be used in all Keystone-compatible outlet sockets, patch panels, and panel cut-outs. The construction with socket and cable stub provides the physical functionality of an extension cable.

Low-frequency signal components are strongly attenuated, protecting connected devices from ground loops.

The EMOSAFE EN-65 Network Isolator transmits high-frequency signals through the principle of electromagnetic induction. This results in the EN-65 not requiring any external power supply. There are no software drivers to be installed.

## 3 APPLICATIONS

---

### 3.1 PATIENT PROTECTION

Electrical separation of Ethernet interfaces of medical electrical (ME) devices and systems, where patients must be protected from dangerous leakage currents, in conformity with applicable standards.

### 3.2 EQUIPMENT PROTECTION

Applications, in which valuable or critical devices or those requiring special protection need to be protected against ripple, mains hum, and surge voltages from the network periphery.

### 3.3 MEASUREMENT TECHNOLOGY

Electrical measuring and monitoring equipment, which needs to be protected against external and interference voltages arising from the Ethernet periphery.

### 3.4 POTENTIAL DIFFERENCES (TECHNICAL BUILDING SYSTEMS)

Computer systems, which are electrically connected with each other over significant distances via Ethernet cabling, where current flows caused by potential differences must be prevented.



### 3.5 AUDIO

Audio applications, in which the transmission of low frequency alternating current voltages (mains hum) over the network connection is to be reduced to an imperceptible level.

## 4 SUMMARY OF VARIANTS

### EN-65

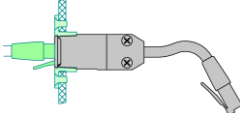
Installation Network Isolator with Cable

	Name	Special features	AC dielectric strength (kV)	TVS diodes	10/100/1000 Mbit/s	Typical Return Loss (dB) @ 100 MHz	Typical Insertion Loss (dB) @ 100 MHz	Configuration
<b>SnapFit</b> 	<b>EN-65S</b> A10069	High performance. Physical interface for use with EMOSAFE SnapFit accessories.	5.0	✓	✓	20.0	0.5	
<b>Keystone</b> 	<b>EN-65K</b> A10068	High performance. For use in Keystone-compatible outlets.	5.0	✓	✓	20.0	0.5	

## 5 TECHNICAL DRAWINGS

### 5.1 EN-65S

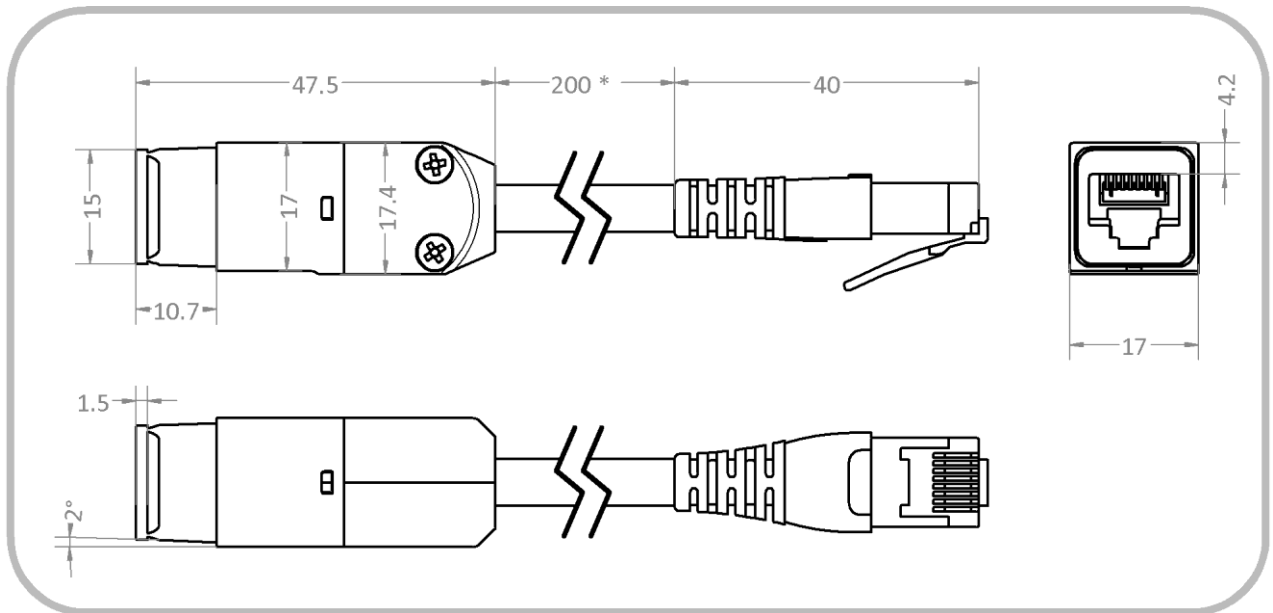

Figure 1. Technical drawing for EN-65S. All dimensions are in millimetres.

### 5.2 EN-65K

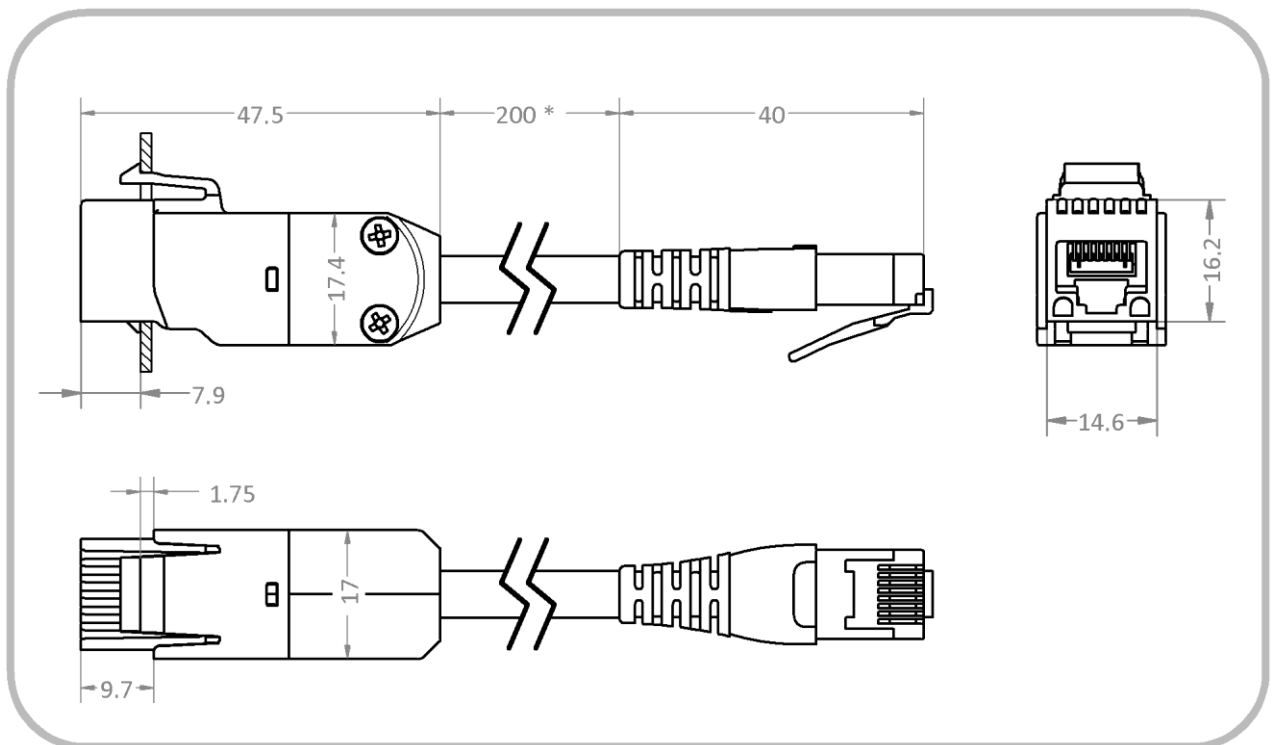

Figure 2. Technical drawing for EN-65K. All dimensions are in millimetres.



\* Standard cable length of 200 mm. A selection of other cable lengths from 30 mm to 10 m are available upon request.

6 ACCESSORIES

6.1 OVERVIEW

SnapFit

Installation frames for SnapFit variants

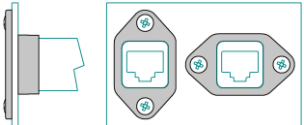
	Name Article number	Special features	Configuration
	<b>Z-3-SF-INT</b> A10057	<ul style="list-style-type: none"> <li>Housing assembly for flush mounting</li> <li>Two M2.5 brass inserts</li> <li>Two snap-fit positions</li> <li>Material: polyamide, black</li> </ul>	
	<b>Z-4-SF-EXT</b> A10058	<ul style="list-style-type: none"> <li>Protruding housing assembly</li> <li>Two snap-fit positions</li> <li>Material: polyamide, black</li> </ul>	

6.2 Z-3-SF-INT

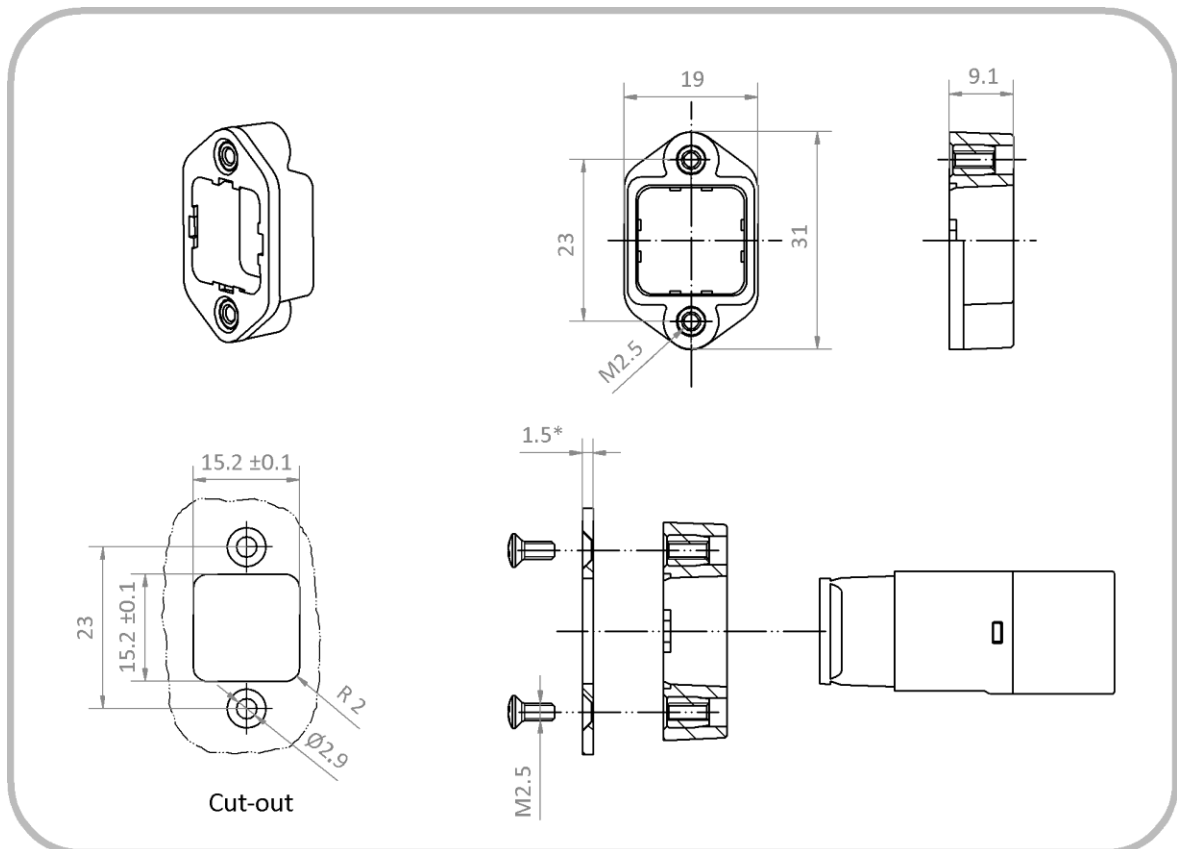

Figure 3. Physical dimensions and required cut-out for SnapFit installation frame Z-3-SF-INT. No maximum screw length.

\* 1.5 mm is recommended to achieve flush mounting. Deviations from this panel thickness are possible.

6.3 Z-4-SF-EXT

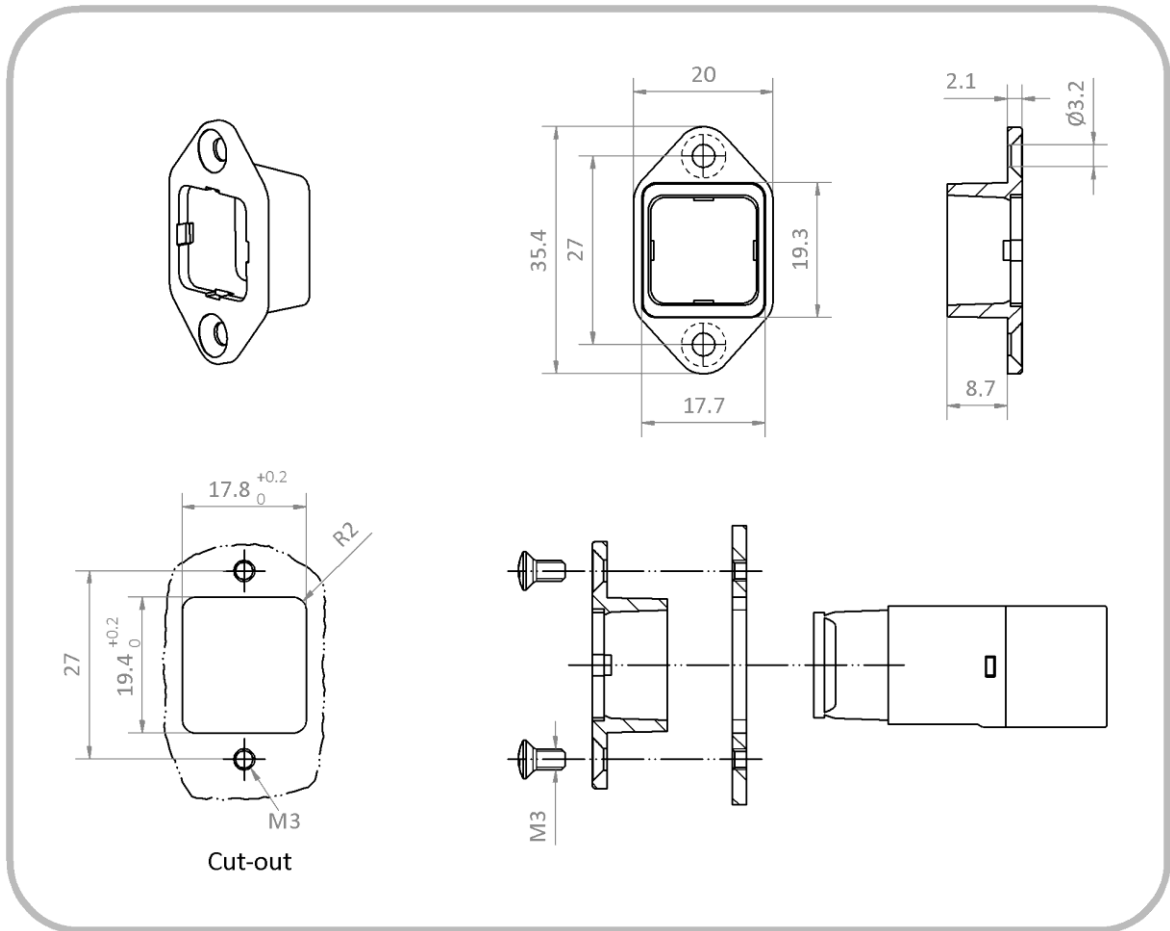

Figure 4. Physical dimensions and required cut-out for SnapFit installation frame Z-4-SF-EXT

## 7 INSTALLATION

### 7.1 EN-65K

The Network Isolator EN-65K can be snapped into any housing aperture which corresponds to the Keystone dimension requirements shown in Figure 5. It is therefore compatible with many wall outlets and rack systems from various manufacturers, and is especially suitable for use within cable ducts and medical supply units.

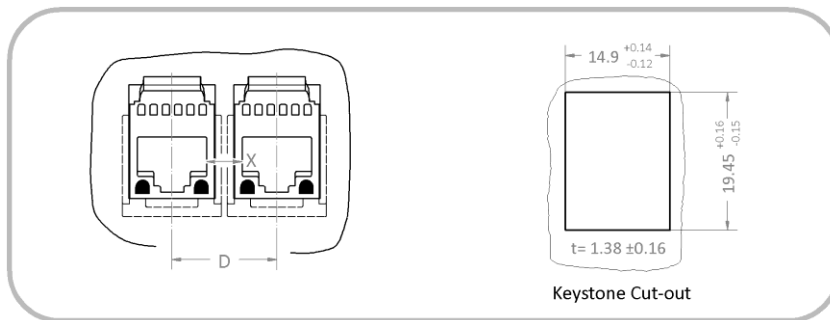

Figure 5. Dimensions for Keystone-compatible cut-outs, and required panel thickness.

Figure 6 shows a typical assembly within a cable duct (10), with cover (11). The Network Isolator EN-65K (1) is shown installed in a Keystone-compatible wall outlet, which usually consists of a support frame (5) and a plastic front panel (4). The RJ45 plug (3) of the Network Isolator is to be inserted into a RJ45 jack module termination (7) at the end of the permanently installed data cable (8). When retrofitting the Network Isolator EN-65K (1) into network channels, the existing RJ45 jack module from the wall outlet can be shifted back within the cable duct (10), and used as the connection to the Network Isolator.

The interface at the RJ45 jack module (7) between the permanently installed cable and the Network Isolator must be kept accessible if regular safety checks are to be conducted, or if the ability to subsequently verify the permanent installation is required. If this is not already made possible by a removable duct cover (11), we recommend the installation of a service access panel (6).

The EN-65K Network Isolator also interrupts the shield connection. Should the cable shield of the permanently installed network cable (8) need to be connected with the room or equipment potential, this must occur at the shifted-back RJ45 jack module (7), i.e. with the help of an earthing wire (9).

Permanent tensile loading on the connecting cable (2) is not permitted.

If it is intended that two or more EN-65K Network Isolators will be installed side by side into multiple module carriers, the mounting distance "D" in Figure 5 must be taken into account. Crucial to this is the creepage distance across the dimension "X" in Figure 5, between the shield plates of the inserted RJ45 plugs. The resulting creepage distance must not fall short of 8 mm (250 V AC), or 12 mm (400 V AC), as appropriate for the voltage scenario. The centre-to-centre distance "D" can however be reduced, if the creepage distance across the dimension "X" is increased accordingly (e.g. by adding plastic dividers). Combining EMOSAFE Network Isolators and non-galvanically isolated Keystone modules within module carriers is not recommended.

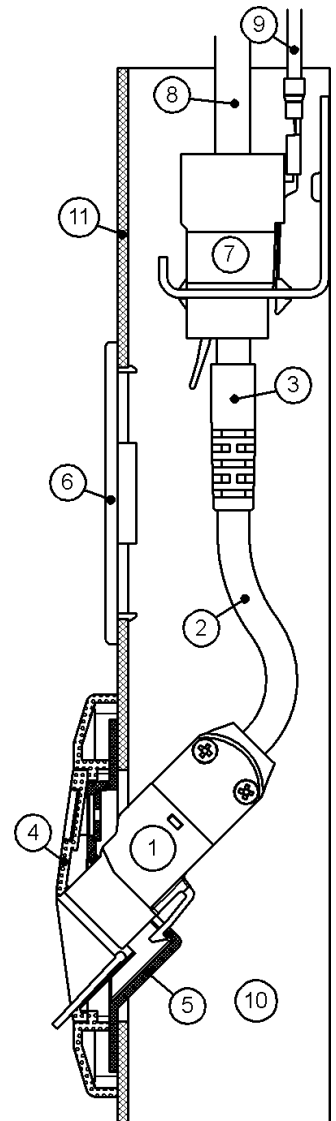

Figure 6

## 7.2 EN-65S

The EN-65S Network Isolator is intended for incorporation into electronic devices, and it provides a Snap-Fit interface for this purpose. An example configuration is shown in Figure 7.

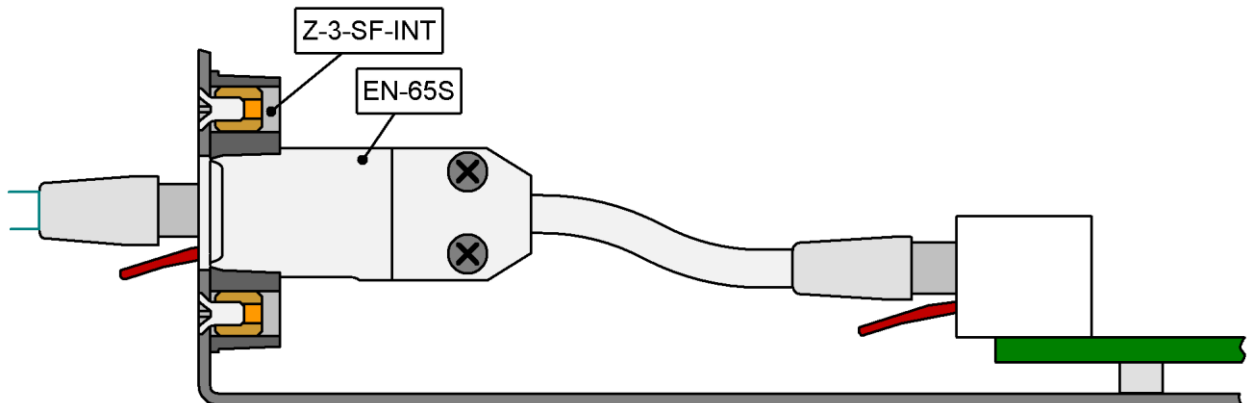

Figure 7. Example configuration of the EN-65S installed in combination with the Snap-Fit accessory Z-3-SF-INT.

SnapFit installation frames are available as accessories for the EN-65S; providing panel mounting which is secure and free from play. The physically square interface allows for four different attachment positions. The production of customer-specific SnapFit frames is possible upon request.

**ATTENTION:** *SnapFit installation frames are no longer removable after being snapped into place. Therefore please pay attention to the correct plug-in position when assembling!*

## 7.3 FREQUENCY RANGE

EN-65 Network Isolators are designed for data transmission in the frequency range of 300 kHz to 100 MHz. Lower frequencies are strongly attenuated. For this reason, it is generally not possible to transmit the signals from nurse call systems, telephone systems or analogue audio / video signals over a Network Isolator.

## 7.4 POWER OVER ETHERNET

The EN-65 Network Isolator can be used in a Power over Ethernet (PoE) network without restriction (however PoE devices downstream of the electrical isolation are not supplied with power).

## 7.5 QUALITY REQUIREMENTS ON CABLE INSTALLATIONS

In order for a cabling path in which an EN-65 Network Isolator is installed to meet the Permanent Link requirements of Class D or Cat.5e, the cable installation (without the Network Isolator) must provide a performance reserve. The following performance reserves (clearances from the margins) to the Class D or Cat.5e margins must be met or exceeded when measuring the cable installation without the Network Isolator:

NEXT:	4.0 dB
Return Loss:	4.0 dB
Insertion Loss:	1.5 dB + 0.27 dB/m

The Insertion Loss (IL) reserve is to be calculated for the length of the chosen EN-65 Network Isolator.

Example: an EN-65 with a 3 m cable length requires an IL reserve of:  $1.5 \text{ dB} + 3 \text{ m} \times 0.27 \text{ dB/m} = 2.31 \text{ dB}$



## 8 SAFETY NOTICE

---

### 8.1 ASSEMBLY

During design and assembly into medical electrical systems, attention should be paid to clearance and creepage distances, to ensure that the distances required by IEC 60601-1 are met. The isolating effect of the Network Isolator must not be compromised by neighbouring conductive components. If, for example, the installation of the Network Isolator is to be within a metal plate, this plate must be connected to the ground potential (protective earth).

The EN-65 Network Isolator should always terminate a cable route. Installations that are set back within cable ducts, as well as installations in remote patch panels, are not recommended because the protective properties of the Network Isolator are guaranteed only directly at its own RJ45 output.

### 8.2 ENCLOSURE AND CONNECTION AREAS

The Network Isolator provides excellent protection between input and output, however the plastic enclosure provides only basic isolation. Furthermore, the connected plugs and the areas around the receptacles may have metal surfaces accessible to human contact, and therefore provide no protection. If the risk management process of the responsible organisation (i.e. manufacturer or operator, as defined in IEC 60601-1) reveals unacceptable risks that operators or patients can touch the housing or exposed conducting parts while the Ethernet cabling is connected to a potentially dangerous voltage, the Network Isolator and the exposed conducting surfaces must be surrounded with an appropriate enclosure to ensure the required means of protection for the application.

### 8.3 DAMAGE AND CONTAMINATION

Damaged Network Isolators, and Network Isolators which are contaminated by dust or liquids, are to be replaced.

## 9 SAFETY AND FUNCTION TESTING

---

### 9.1 FUNCTION AND COMPLIANCE TESTING

The transmission properties of permanent network installations fitted with EN-65 Network Isolators can be checked with cable certification devices which are suitable for testing electrically isolated cable sections. To be able to conduct such an inspection, the test equipment must be configured in an AC wire-map mode. The entire cable route, including the Network Isolator, can be tested to EIA/TIA-568 Cat.5e or ISO 11801 Class D. Testing of the cable shielding and the conductor resistance is not possible in this mode. If however, these tests are required, or if the quality of the cable route itself needs to be tested (without the Network Isolator), then testing can be performed by bypassing the Network Isolator, and connecting directly to the RJ45 socket ⑦, set back within the cable duct, as indicated in Figure 6.

### 9.2 SAFETY INSPECTIONS

Regular safety inspections and post-repair inspections are not prescribed for network isolators in medical use, as network isolators themselves are not classified as medical electrical (ME) devices. However, together with a connected medical device, network isolators form an ME system, which altogether may be subject to inspection. The test interval, as well as the requirements to be met for both regular safety inspections and post-repair inspections will be specified by the responsible organisation (i.e. manufacturer

or operator, as defined in IEC 60601-1), and based upon the applicable standards for the entire ME system.

To simplify implementation, the system components (in this case, the network isolator) can be individually tested. The responsible organisation provides the test parameters, specifies the test interval, and specifies the actions to take when a component fails the test. Such an assessment may, depending upon requirements, include the following checks:

#### 9.2.1 VISUAL INSPECTION

Check for evidence of external damage and ingress of substances; dust or liquids for example.

#### 9.2.2 LEAKAGE CURRENT TEST

The leakage current is to be measured, to ensure that it falls within the prescribed limits. For this purpose, test equipment which can perform equipment leakage current measurements in accordance with IEC 62353 may be used. To perform a leakage current test, all conductors on the input side must be short-circuited together, and all the conductors on the output side must also be short-circuited together. The AC test voltage specified by the responsible organisation is then applied across these two connections. Input and output sides are interchangeable. The expected current flow can be found in section [11 SPECIFICATIONS](#).

#### 9.2.3 HIPOT TEST

To ensure that the device under test is not damaged, it is recommended that a DC voltage source is used in place of the AC voltage source, and that the DC voltage is 1½ times that of the required AC voltage. The test setup is essentially the same as that of the Leakage Current Test above. The expected dielectric strength can be found in section [11 SPECIFICATIONS](#).

#### 9.2.4 FUNCTIONAL TEST

After conducting the tests above, and reconnecting the Network Isolator into the network, an examination is recommended to ensure that the signal transmission is performing correctly. Such a functional test can be performed, for example, with a suitable Ethernet cable certification device. Refer to the section [9.1 FUNCTION AND COMPLIANCE TESTING](#).

## 10 MODEL OPTIONS AND ORDERING INFORMATION

### 10.1 NOTES

The length of the flexible cable stub ② (see Figure 6 in section 7.1) of the EN-65 Network Isolator is available in selected lengths from 30 mm to 10 m (inclusive). Refer to Figure 8 and Figure 9, as well as the table in section 10.4. It is recommended that this length be kept to a minimum. When compared to a fixed installed cable, this flexible cable stub may be more susceptible to near end crosstalk (NEXT) and alien crosstalk (AXT). The flexible cable stub itself generates a small, but length-dependent amount of insertion loss (IL).

Refer to section 7.5 *QUALITY REQUIREMENTS ON CABLE INSTALLATIONS*.

For flexible cable stub lengths between 30 mm and 500 mm (inclusive), the plug angle can be chosen, easing mechanical constraints in certain assembly configurations, and removing impermissible torsion strains from the cable assembly. Refer to Figure 8 and Figure 9. The manufacturing tolerance for the plug angle is  $\pm 20^\circ$ .

### 10.2 TECHNICAL DRAWING: EN-65S (A10069)

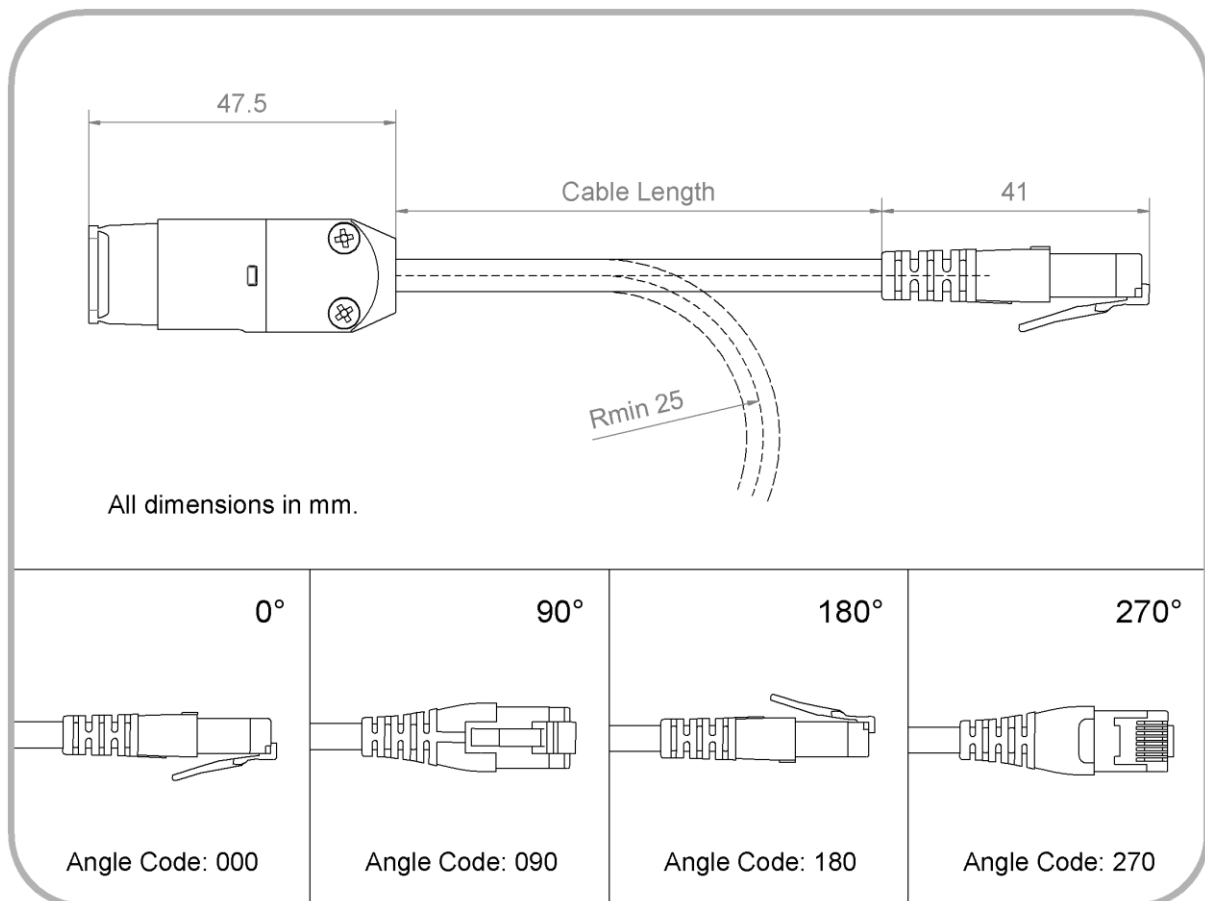

Figure 8. Technical drawing for EN-65S, showing definition of cable length, as well as angle codes.

10.3 TECHNICAL DRAWING: EN-65K (A10068)

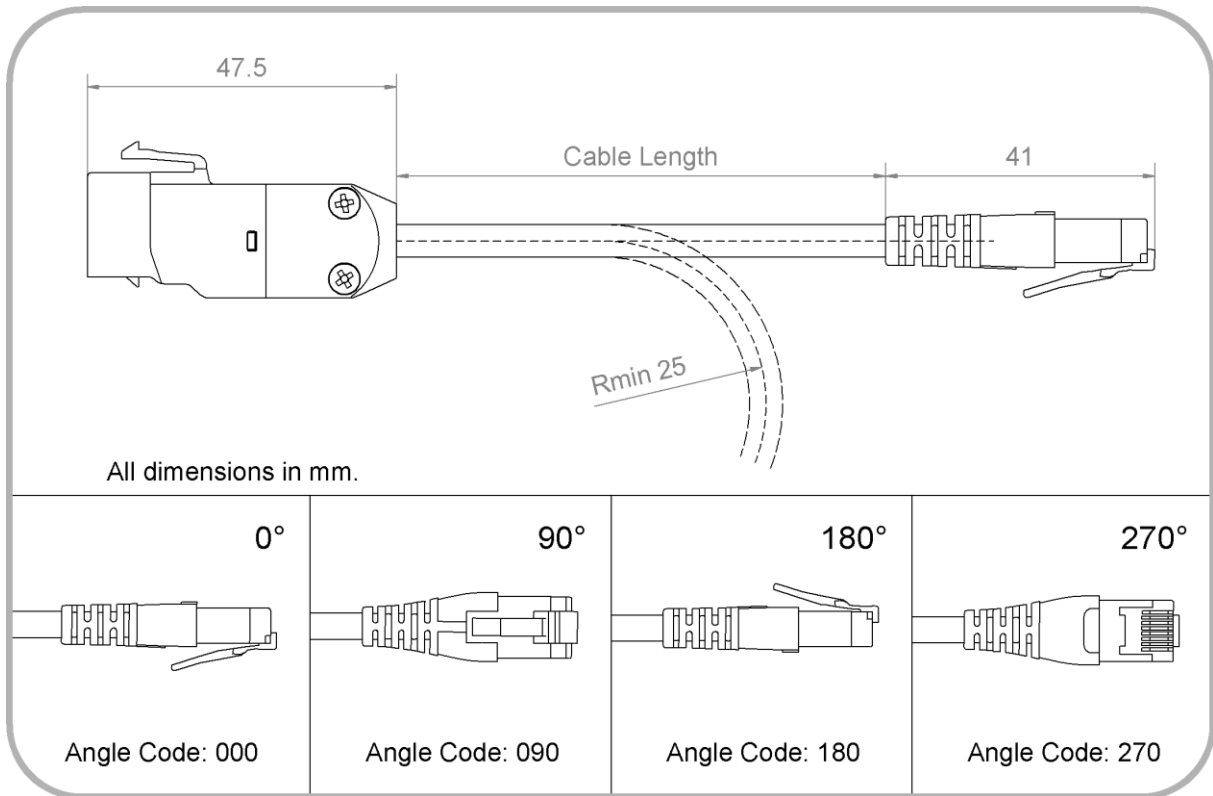

Figure 9. Technical drawing for EN-65K, showing definition of cable length, as well as angle codes.

10.4 AVAILABLE CABLE LENGTHS

Length Groups	Step	Length Tolerance	Length Code
30, 40, ... 100 mm	10 mm	± 5 mm	00030 ... 00100
120, 140, ... 300 mm	20 mm	± 7 mm	00120 ... 00300
350, 400, ... 1000 mm	50 mm	± 15 mm	00350 ... 01000
1100, 1200, ... 3000 mm	100 mm	± 30 mm	01100 ... 03000
3500, 4000, ... 10000 mm	500 mm	± 50 mm	03500 ... 10000

10.5 ORDER NUMBERS

When placing orders for EN-65, please specify the exact Order Code (OC). The order number is a hyphenated concatenation of the Article Number (A10068 for EN-65K, or A10069 for EN-65S), the Length Code for the desired cable length (see section 10.4 above), and the Angle Code for the desired plug angle (see Figure 8 and Figure 9). For flexible cable stub lengths greater than 500 mm, the EN-65 will always be manufactured with a plug angle of 0°, and the Angle Code can be omitted for such orders.

The following example shows the complete Order Code for an EN-65K with 400 mm cable length and a plug angle at 180°.

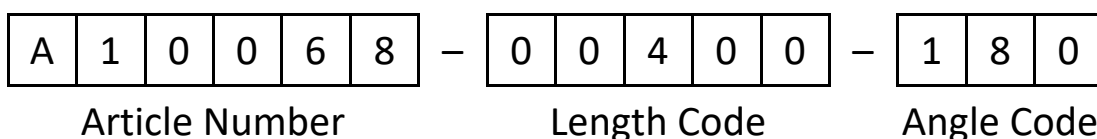

## 11 SPECIFICATIONS

### 11.1 GENERAL

Category	Standards or Test Criteria	Property
Designation		EMOSAFE EN-65K, EMOSAFE EN-65S
Housing Colour		White
Housing Material		Plastic
Construction		EN-65K: Keystone Module with Cable EN-65S: SnapFit Module with Cable
Cable Length	Flexible cable segment between plug and housing	Selected lengths between 30 mm and 10 m (inclusive). Refer to section 10.4
Minimum Bending Radius		25 mm
Maximum short-term loading upon cable		70 N for up to 10 s
Input Interface		RJ45 Jack, straight
Output Interface		RJ45 Plug, cable
Weight	with 200 mm cable length	approximately 26 g
Protection Rating	EN 60529	IP40
Mating Cycles:	Correct: RJ45 plug in RJ45 socket	> 1000 cycles
	Mismatched: with RJ11 / RJ12 / RJ25	maximum of 100 cycles
Mean Time To Failure (MTTF)	SN 29500 Standard Temperature: 25°C Duty cycle: 100% (24 hours, 7 days)	3,240 years
	SN 29500 Standard Temperature: 40°C Duty cycle: 100% (24 hours, 7 days)	3,070 years

## 11.2 ETHERNET PERFORMANCE

Category	Standards or Test Criteria	Property
Transmission Speeds and Supported Network Protocols	10 Mbit/s, 10Base-T (IEEE802.3 Cl.14)	✓
	100 Mbit/s, 100Base-Tx (IEEE802.3 Cl.25)	✓
	1000 Mbit/s, 1000Base-T (IEEE802.3 Cl.40)	✓
Performance Category	ISO 11801, Permanent Link (PL)	Class D
Insertion Loss (absolute)	Typical:	0.5 dB * @ 100 MHz
	Maximum:	0.8 dB * @ 100 MHz
Return Loss (absolute)	Typical:	20.0 dB @ 100 MHz
	Minimum:	14.0 dB @ 100 MHz

## 11.3 ELECTRICAL

Category	Standards or Test Criteria	Property	
AC Dielectric Strength	at 50 Hz, for 60 seconds	5.0 kV	
DC Dielectric Strength	for 60 seconds	8.5 kV	
Reinforced Isolation	IEC 60601-1	✓	
Coupling Capacitance per Channel		37.5 pF ±25%	
Total Coupling Capacitance		150 pF ±25%	
Total Leakage Current	275 V AC at 50 Hz	Typical:	12.0 µA
		Maximum:	16.0 µA
TVS diode circuitry	Suppression of transients on the signal lines	✓	

\* Valid for EN-65 Network Isolators with a cable length of 200 mm. For other lengths, maximum is 0.7 dB + (0.27 dB/m × length).

#### 11.4 OPERATING CONDITIONS AND AREA OF APPLICATION

Category	Standards or Test Criteria		Property
Pollution Degree	IEC 61010		2 *
Overvoltage Category	IEC 60664-1		III
Maximum Working Voltage †	Maximum mains voltage of the connected devices, in accordance with IEC 60601-1		400 V AC 450 V DC
Temperature		Minimum:	-10°C
		Maximum:	+60°C
Air Humidity	Non-condensing	Minimum:	10%
		Maximum:	90%
Air Pressure		Minimum:	700 hPa
		Maximum:	1,060 hPa
Altitude		Maximum:	3,200 m

#### 11.5 ENVIRONMENTAL CONDITIONS: STORAGE AND TRANSPORTATION

Category	Standards or Test Criteria		Property
Temperature		Minimum:	-40°C
		Maximum:	+70°C
Air Humidity	Non-condensing	Minimum:	10%
		Maximum:	90%
Air Pressure		Minimum:	500 hPa
		Maximum:	1,060 hPa

\* Normally only nonconductive pollution occurs. Temporary conductivity caused by condensation is to be expected.

† The Network Isolator can be permanently exposed to this voltage level.

## 11.6 CERTIFICATES

Category	Property
UL Recognized Component	✓
UL File No.	E249126 E362969
IEC 60601-1	✓
IEC 60601-1-2	✓
ANSI/AAMI ES 60601-1	✓
CAN/CSA-C22.2 No. 60601-1	✓
Low Voltage Directive	✓
EMC Directive	✓
RoHS Directive	✓
Lead-free	✓

The versions of the cited standards and directives to which our products comply with can be found in our Declaration of Conformity and our UL certificate on our website under "[Standard Conformity and Certificates](#)".



### 11.7 ISOLATION DIAGRAM

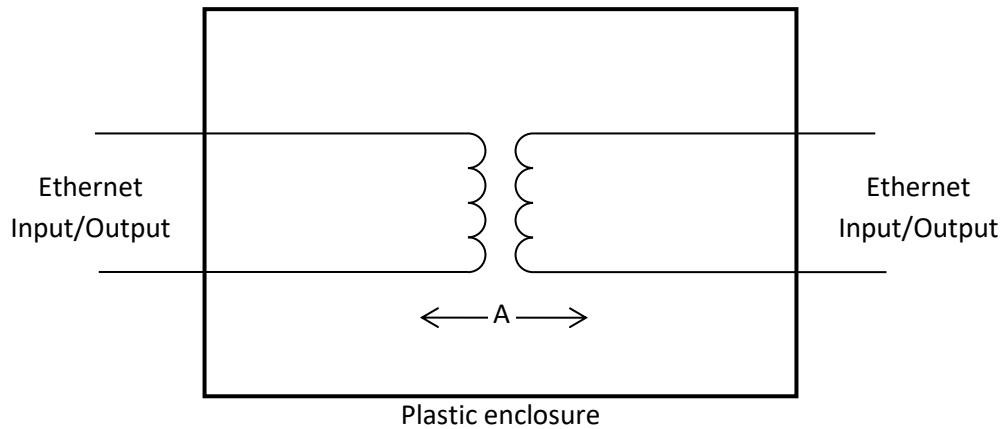

Figure 10. Isolation diagram for EN-65

Area	Number and type of Means of Protection	Material Group (from CTI)	Maximum Operating Voltage		Required creepage distance (mm)	Required clearance distance (mm)	Measured creepage distance (mm)	Measured clearance distance (mm)
			V AC	V <sub>peak</sub>				
A	2 MOPP *	IIIb †	400	565	12.0	7.0	12.0	9.0

\* MOPP = Means of Patient Protection

† Materials in the Material Group IIIb have a Comparative Tracking Index (CTI) value between 100 and 175.

### 11.8 FREQUENCY RESPONSE

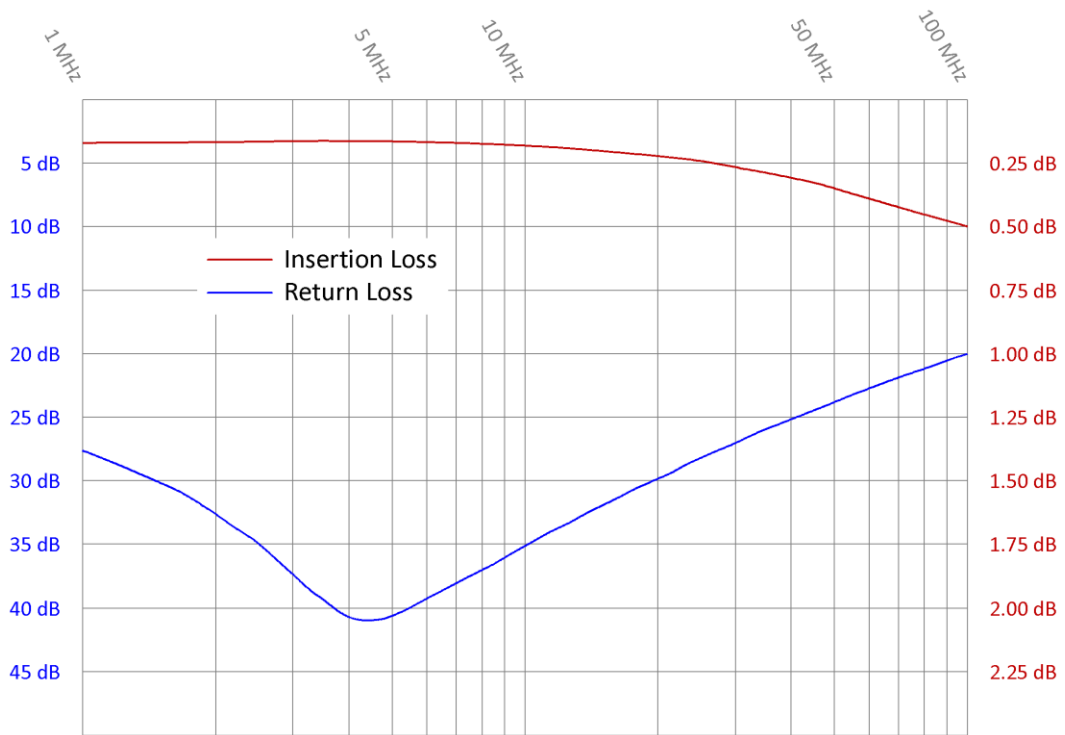

Figure 11. Typical frequency response for EN-65 with a 200 mm cable stub length.

## 12 SCHEMATIC DIAGRAM

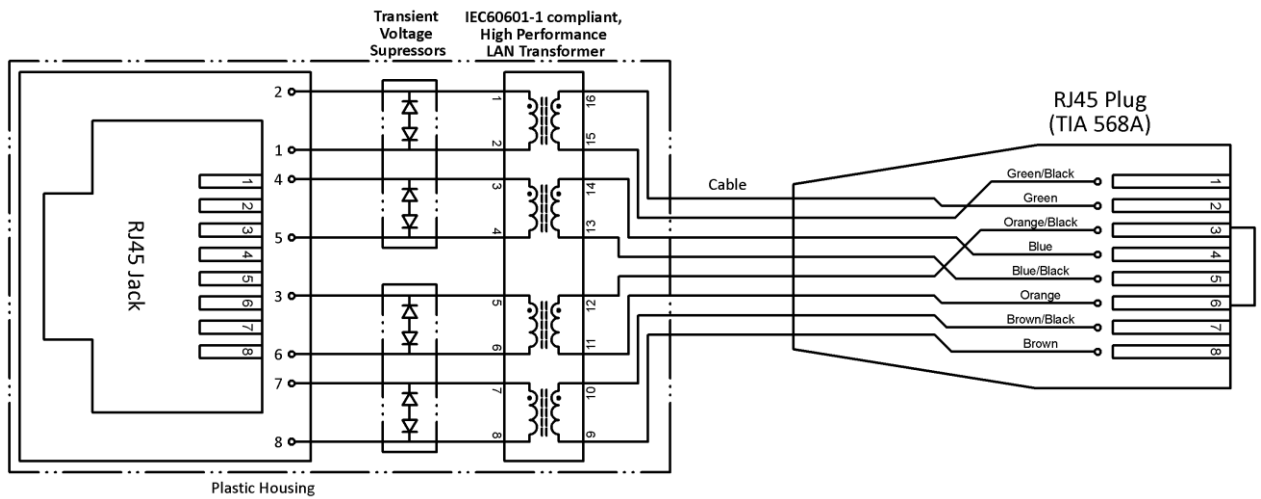

Figure 12. Schematic diagram of the EN-65.

## 13 PACKAGING





Contents:

- One of: EN-65K or EN-65S
- Installation Guide

A packaging label provides the following information:

- Article Description
- Quantity
- Cable Length (for customer specific products)
- Plug Angle (for customer specific products)
- Part Number (PN) (or Order Code (OC) for customer specific products)
- Date of Manufacture
- Serial Number (SN)
- The Serial Number is printed as both a linear (Code 128) and a 2-D Barcode (Data Matrix)

## 14 PRODUCT MARKINGS

	Through this mark, the conformity of the product with all applicable EU Directives is confirmed.
	Designates the product as a UL "Recognised Component"; File numbers E249126 and E362969.
	The product may not be disposed of in domestic rubbish.
	This product contains no substances containing lead and is manufactured using lead-free solder.
	This product meets the requirements of EU Directive concerning the limitation of the use of certain hazardous substances in electric and electronic equipment.

## 15 SCHEDULED MAINTENANCE

When used as directed, EMOSAFE Network Isolators are maintenance-free.

## 16 ENVIRONMENTAL PROTECTION INFORMATION

This device contains electronic components. At the end of its service life it is to be returned to the manufacturer for disposal.

## 17 QUALITY

---

EMO Systems operates a certified quality management system for development and production in accordance with ISO 9001 and ISO 13485. Prior to delivery, each Network Isolator is subjected to a comprehensive quality inspection. This inspection ensures, among other factors, that the attained values for leakage currents, dielectric withstand strengths, insertion losses, return losses, and near end crosstalk values all meet the specified requirements.

## 18 CONTACT AND SUPPORT

---

Please find our up-to-date contact details on our website: <http://www.emosystems.de/en/contact>

Or send us an e-mail at the following address: [support@emosystems.de](mailto:support@emosystems.de)

## 19 LEGAL NOTIFICATION

---

The information provided above in this datasheet has been compiled with all due care, and is believed to be accurate and reliable. However, we cannot guarantee that the information contained is completely free from error.

The end user is responsible and liable for the proper use of this product; EMO Systems GmbH. assumes no liability. We reserve the right to make changes to this datasheet without notice.



Компания «ЭлектроПласт» предлагает заключение долгосрочных отношений при поставках импортных электронных компонентов на взаимовыгодных условиях!

Наши преимущества:

- Оперативные поставки широкого спектра электронных компонентов отечественного и импортного производства напрямую от производителей и с крупнейших мировых складов;
- Поставка более 17-ти миллионов наименований электронных компонентов;
- Поставка сложных, дефицитных, либо снятых с производства позиций;
- Оперативные сроки поставки под заказ (от 5 рабочих дней);
- Экспресс доставка в любую точку России;
- Техническая поддержка проекта, помощь в подборе аналогов, поставка прототипов;
- Система менеджмента качества сертифицирована по Международному стандарту ISO 9001;
- Лицензия ФСБ на осуществление работ с использованием сведений, составляющих государственную тайну;
- Поставка специализированных компонентов (Xilinx, Altera, Analog Devices, Intersil, Interpoint, Microsemi, Aeroflex, Peregrine, Syfer, Eurofarad, Texas Instrument, Miteq, Cobham, E2V, MA-COM, Hittite, Mini-Circuits, General Dynamics и др.);

Помимо этого, одним из направлений компании «ЭлектроПласт» является направление «Источники питания». Мы предлагаем Вам помощь Конструкторского отдела:

- Подбор оптимального решения, техническое обоснование при выборе компонента;
- Подбор аналогов;
- Консультации по применению компонента;
- Поставка образцов и прототипов;
- Техническая поддержка проекта;
- Защита от снятия компонента с производства.



#### Как с нами связаться

**Телефон:** 8 (812) 309 58 32 (многоканальный)

**Факс:** 8 (812) 320-02-42

**Электронная почта:** [org@eplast1.ru](mailto:org@eplast1.ru)

**Адрес:** 198099, г. Санкт-Петербург, ул. Калинина, дом 2, корпус 4, литера А.