

USB3.0-IP FMC demo board Manual [Ver2.0E]

AB07-USB3FMC (2.5V I/O) or AB07-USB3FMC-1.8VIF (1.8V I/O)

Introduction

Thank you for choosing USB3.0-IP FMC demo board [Part Number: AB07-USB3FMC] (“demo board” in this manual).

The demo board will connect with FPGA Evaluation board that furnishes FMC extension connector, so that user can evaluate USB3.0-IP from DesignGateway. The demo board can be applicable to both USB3.0 Device-IP (Product number: USB3D-IPxxx) evaluation and Host-IP (Product number: USB3H-IPxxx) evaluation. **Take enough care that FMC interface voltage of the demo board is fixed, so that user shall never use any FPGA board that cannot adjust to proper FMC I/O voltage. Otherwise, FPGA board or the demo board will be damaged!**

User can try USB3.0 SuperSpeed real board operation by using FPGA board with this demo board and bit-file for evaluation provided from DesignGateway.

The demo board mainly mounts following parts.

- TUSB1310A (USB3.0 PHY device from T.I) and related power supply circuit.
- A-type USB3.0 connector
- FMC-LPC connector

The 1meter-length USB3.0 AtoA cable is attached with the demo board product. USB3.0 Device-IP core (Product Name: USB3D-IPxxx) evaluation needs to use this USB3.0 cable. Note that USB3.0 AtoB cable is not attached with the product, so that user needs to arrange USB3.0 AtoB cable to evaluate USB3.0 Host-IP core (Product Name: USB3H-IPxxx).

Note that the demo board only supports SuperSpeed (5Gbps) communication and does not support any legacy USB speed. (There is no DM/DP signal connection resource for USB2.0 or earlier standard) because the demo board is dedicated to USB3.0-IP from DesignGateway only.

Package List

The demo board includes following items in its product.

- USB3FMC board: 1pcs
- USB3.0 AtoA cable: 1pcs. (AtoA cable is for Device-IP core evaluation)

Board Outline

The demo board size is 69mm width and 58.65mm length.
Following figure-1 shows board outline.

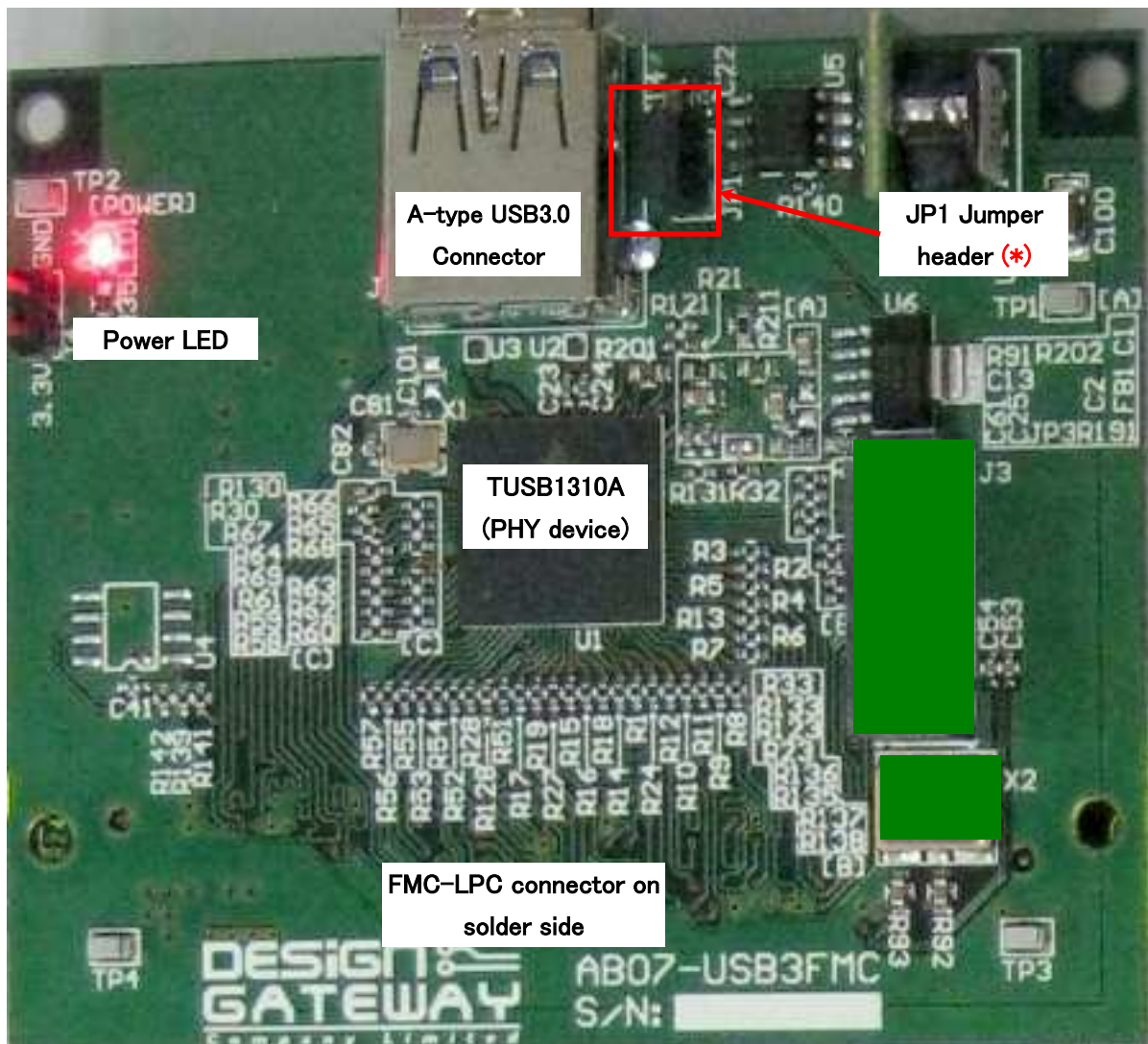

Figure-1: AB07-USB3FMC board outline

Note(*): JP1 Jumper header is to set short or open between 5V power supply from USB (VUSB) and on-board 5V power supply output.

When evaluate Device-IP, do not set Jumper Socket on JP1.

When evaluate Host-IP, set Jumper Socket on JP1.

Pin Assignment

Pin assignment between FPGA I/O pin and TUSB1310 is listed following table-1. For AB07-USB3FMC-1.8VIF, this board only supports 1.8V I/O so that it cannot connect with SP605 or ML605, however, signal connection information between FMC pin and TUSB1310A is same as AB07-USB3FMC.

Demo Bd.FMC-LPC		TUSB1310A on Demo Bd		XC6SLX45 on SP-605		XC6VLX240 on ML-605		Remark
FMC Pin#	FMC definition	Chip Pin#	TUSB1310A signal name	FPGA PIN#	Spartan-6 pin attribution	FPGA PIN#	Virtex-6 pin attribution	
C10	LA06_P	P2	TX_DATA4	D4	L2P_0	K33	L16P_16	
C11	LA06_N		USB_PWEN	D5	L2N_0	J34	L16N_16	Not used
C14	LA10_P	M1	TX_DATA8	H10	L33P_0	F30	L3P_16	
C15	LA10_N	F3	RX_ELECIDLE	H11	L33N_0	G30	L3N_16	
C18	LA14_P	G2	TX_DATA15	C17	L50P_0	C33	L6P_16	
C19	LA14_N			A17	L50N_0	B34	L6N_16	
C22	LA18_P_CC	C2	RX_DATA4	T12	L29P_GC_2	L29	L11P_SC_15	
C23	LA18_N_CC	D3	RX_TERM	U12	L29N_GC_2	L30	L11N_SC_15	
C26	LA27_P	B4	RX_DATA10	AA10	L41P_2	R31	L14P_15	
C27	LA27_N			AB10	L41N_2	R32	L14N_15	
D8	LA01_P_CC	P3	TX_DATA2	F14	L36P_GC_0	F31	L11P_SC_16	
D9	LA01_N_CC	L11	TX_DEEMPH0	F15	L36N_GC_0	E31	L11N_SC_16	
D11	LA05_P	N2	TX_DATA5	C4	L6P_0	H34	L14P_16	
D12	LA05_N	K11	TX_DEEMPH1	A4	L6N_0	H33	L14N_16	
D14	LA09_P	M2	TX_DATA9	F7	L7P_0	L25	L18P_16	
D15	LA09_N	K3	TX_ELECIDLE	F8	L7N_0	L26	L18N_16	
D17	LA13_P	H1	TX_DATA13	G16	L51P_0	D34	L8P_SC_16	
D18	LA13_N			F17	L51N_0	C34	L8N_SC_16	
D20	LA17_P_CC	A6	PCLK	Y11	L32P_GC_2	N28	L9P_MC_15	
D21	LA17_N_CC		(GND)	AB11	L32N_GC_2	N29	L9N_MC_15	
D23	LA23_P	B1	RX_DATA5	U9	L50P_2	R28	L18P_15	
D24	LA23_N	C7	RX_STATUS2	V9	L50N_2	R27	L18N_15	
D26	LA26_P	A3	RX_DATA7	U14	L16P_2	L33	L6P_15	
D27	LA26_N			U13	L16N_2	M32	L6N_15	

Table-1: Pin connection list

Demo Bd.FMC-LPC		TUSB1310A on Demo Bd		XC6SLX45 on SP-605		XC6VLX240 on ML-605		Remark
FMC Pin#	FMC definition	Chip Pin#	TUSB1310A signal name	FPGA PIN#	Spartan-6 pin attribution	FPGA PIN#	Virtex-6 pin attribution	
G2	CLK1_M2C_P			E16	L37P_GC_0	F33	L10P_MC_16	
G3	CLK1_M2C_N			F16	L37N_GC_0	G33	L10N_MC_16	
G6	LA00_P_CC	P5	TX_DATA0	G9	L34P_GC_0	K26	L9P_MC_16	
G7	LA00_N_CC	M6	TXDET_RXLPBK	F10	L34N_GC_0	K27	L9N_MC_16	
G9	LA03_P	N3	TX_DATA3	B18	L63P_0	J31	L19P_16	
G10	LA03_N	M9	TX_MARGIN0	A18	L63N_0	J32	L19N_16	
G12	LA08_P	P1	TX_DATA6	B20	L65P_0	J30	L13P_16	
G13	LA08_N	J3	PHY_RESETN	A20	L65N_0	K29	L13N_16	
G15	LA12_P	L2	TX_DATA10	H13	L38P_0	E32	L2P_16	
G16	LA12_N	G3	POWER_DOWNN1	G13	L38N_0	E33	L2N_16	
G18	LA16_P	J2	TX_DATA12	C5	L8P_0	A33	L4P_16	
G19	LA16_N	J1	TX_DATAK0	A5	L8N_0	B33	L4N_16	
G21	LA20_P	D1	RX_DATA2	R9	L59P_2	P29	L19P_15	
G22	LA20_N	F1	RX_VALID	R8	L59N_2	R29	L19N_15	
G24	LA22_P	D2	RX_DATA1	V7	L58P_2	N27	L5P_15	
G25	LA22_N	C5	RX_STATUS0	W8	L58N_2	P27	L5N_15	
G27	LA25_P	A2	RX_DATA6	W14	L20P_2	P31	L4P_15	
G28	LA25_N	C6	RX_STATUS1	Y14	L20N_2	P30	L4N_15	
G30	LA29_P	A4	RX_DATA9	T15	L23P_2	N34	L18P_15	
G31	LA29_N	B7	RX_DATAK1	U15	L23N_2	P34	L18N_15	
G33	LA31_P	B8	RX_DATA12	U16	L4P_2	M31	L90P_15	
G34	LA31_N	H11	PWRPRESENT	V15	L4N_2	L31	L90N_15	
G36	LA33_P	B9	RX_DATA15	Y17	L15P_2	K32	L2P_15	
G37	LA33_N		IPL_DD0	AB17	L15N_2	K31	L2N_15	Not used
H2	PRSNT		(GND)	Y16	IO_L17P_2	AD9	L14P_34	
H4	CLK0_M2C_P			H12	L35P_GC_0	A10	L1P_GC_34	
H5	CLK0_M2C_N			G11	L35N_GC_0	B10	L1N_GC_34	
H7	LA02_P	N4	TX_DATA1	G8	L32P_0	G31	L5P_16	
H8	LA02_N	J11	RESETN	F9	L32N_0	H30	L5N_16	
H10	LA04_P	L3	TX_DATA11	C19	L64P_0	K28	L7P_16	
H11	LA04_N	L10	OUT_ENABLE	A19	L64N_0	J29	L7N_16	
H13	LA07_P	N1	TX_DATA7	B2	L3P_0	G32	L17P_16	
H14	LA07_N	H3	POWER_DOWNN0	A2	L3N_0	H32	L17N_16	
H16	LA11_P	K1	TX_CLK	H14	L49P_0	D31	L15P_16	
H17	LA11_N		(GND)	G15	L49N_0	D32	L15N_16	
H19	LA15_P	H2	TX_DATA14	D18	L62P_0	C32	L0P_16	
H20	LA15_N	G1	TX_DATAK1	D19	L62N_0	B32	L0N_16	
H22	LA19_P	E2	RX_DATA0	R11	L22P_2	M30	L17P_15	
H23	LA19_N	E3	PHY_STATUS	T11	L22N_2	N30	L17N_15	
H25	LA21_P	C1	RX_DATA3	V11	L42P_2	R26	L15P_15	
H26	LA21_N	E3	PHY_STATUS	W11	L42N_2	T26	L15N_15	
H28	LA24_P	B3	RX_DATA8	AA14	L6P_2	N32	L8P_SC_15	
H29	LA24_N	C8	RX_POLARITY	AB14	L6N_2	P32	L8N_SC_15	
H31	LA28_P	B5	RX_DATA11	AA16	L19P_2	N33	L10P_MC_15	
H32	LA28_N	A7	RX_DATAK0	AB16	L19N_2	M33	L10N_MC_15	
H34	LA30_P	A8	RX_DATA13	Y15	L21P_2	M26	L3P_15	
H35	LA30_N		USB_OVCR	AB15	L21N_2	M27	L3N_15	Not used
H37	LA32_P	A9	RX_DATA14	W17	L5P_2	N25	L1P_15	
H38	LA32_N		IPL_DC0	Y18	L5N_2	M25	L1N_15	Not used

Table-1: Pin connection list (cont'd)

Disclaimer

The manufacturer of the product limits liability in following situation or use.

- Any damage to the connected Host-PC via USB interface.
- Any damage to the FPGA evaluation board or the demo board **when user mistakenly connect AB07-USB3FMC with non-2.5V FMC I/F or AB07-USB3FMC-1.8VIF with non-1.8V FMC I/F.**
- Any misoperation in Device-IP evaluation when attached USB3.0 AtoA cable is not used.
- Any misoperation in Host-IP evaluation when USB3.0 cable is not USB3.0 standard compliant.
- DesignGateway does not guarantee transfer speed performance.
- DesignGateway is exempted from any misoperation under user's original environment.

[Inquiry]

URL : <http://www.design-gateway.com>

Email : info@design-gateway.com

Revision History

Revision	Date	Description
1.1E	11-Jul-2012	Initial English manual
1.2E	23-Mar-2015	Remove SATA description
2.0E	08-May-2017	Added AB07-USB3FMC-1.8VIF for 1.8V FMC environment



Компания «ЭлектроПласт» предлагает заключение долгосрочных отношений при поставках импортных электронных компонентов на взаимовыгодных условиях!

Наши преимущества:

- Оперативные поставки широкого спектра электронных компонентов отечественного и импортного производства напрямую от производителей и с крупнейших мировых складов;
- Поставка более 17-ти миллионов наименований электронных компонентов;
- Поставка сложных, дефицитных, либо снятых с производства позиций;
- Оперативные сроки поставки под заказ (от 5 рабочих дней);
- Экспресс доставка в любую точку России;
- Техническая поддержка проекта, помощь в подборе аналогов, поставка прототипов;
- Система менеджмента качества сертифицирована по Международному стандарту ISO 9001;
- Лицензия ФСБ на осуществление работ с использованием сведений, составляющих государственную тайну;
- Поставка специализированных компонентов (Xilinx, Altera, Analog Devices, Intersil, Interpoint, Microsemi, Aeroflex, Peregrine, Syfer, Eurofarad, Texas Instrument, Miteq, Cobham, E2V, MA-COM, Hittite, Mini-Circuits, General Dynamics и др.);

Помимо этого, одним из направлений компании «ЭлектроПласт» является направление «Источники питания». Мы предлагаем Вам помощь Конструкторского отдела:

- Подбор оптимального решения, техническое обоснование при выборе компонента;
- Подбор аналогов;
- Консультации по применению компонента;
- Поставка образцов и прототипов;
- Техническая поддержка проекта;
- Защита от снятия компонента с производства.



Как с нами связаться

Телефон: 8 (812) 309 58 32 (многоканальный)

Факс: 8 (812) 320-02-42

Электронная почта: org@eplast1.ru

Адрес: 198099, г. Санкт-Петербург, ул. Калинина, дом 2, корпус 4, литера А.