

HCPL-314J

0.4 Amp Output Current IGBT Gate Drive Optocoupler



Data Sheet



Description

The HCPL-314J family of devices consists of an Al-GaAs LED optically coupled to an integrated circuit with a power output stage. These optocouplers are ideally suited for driving power IGBTs and MOSFETs used in motor control inverter applications. The high operating voltage range of the output stage provides the drive voltages required by gate controlled devices. The voltage and current supplied by this optocoupler makes it ideally suited for directly driving small or medium power IGBTs. For IGBTs with higher ratings the HCPL-3150(0.5A) or HCPL-3120 (2.0A) optocouplers can be used.

Functional Diagram

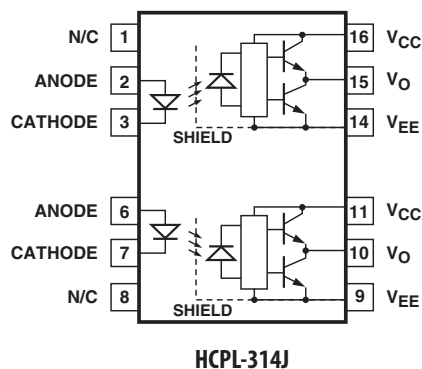

Truth Table

| LED | V _O |
|-----|----------------|
| OFF | LOW |
| ON | HIGH |

A 0.1 μ F bypass capacitor must be connected between pins V_{CC} and V_{EE}.

Features

- 0.4 A minimum peak output current
- High speed response:
0.7 μ s max. propagation delay over temp. range
- Ultra high CMR: min. 25 kV/ μ s at V_{CM} = 1.5 kV
- Bootstrappable supply current: max. 3 mA
- Wide operating temp. range: -40°C to 100°C
- Wide V_{CC} operating range: 10 V to 30 V over temp. range
- Available in DIP8 (single) and SO16 (dual) package
- Safety approvals: UL recognized, 5000 Vrms for 1 minute. CSA approval. IEC/EN/DIN EN 60747-5-2 approval VIORM=1230 Vpeak

Applications

- Isolated IGBT/power MOSFET gate drive
- AC and brushless dc motor drives
- Inverters for appliances
- Industrial inverters
- Switch Mode Power Supplies (SMPS)
- Uninterruptable Power Supplies (UPS)

Selection Guide

| Package Type | Part Number | Number of Channels |
|--------------|-------------|--------------------|
| SO16 | HCPL-314J | 2 |

CAUTION: It is advised that normal static precautions be taken in handling and assembly of this component to prevent damage and/or degradation which may be induced by ESD.

Ordering Information

HCPL-314J is UL Recognized with 5000 Vrms for 1 minute per UL1577.

| Part number | Option | | Package | Surface Mount | Tape & Reel | IEC/EN/DIN EN 60747-5-2 | Quantity |
|-------------|----------------|--------------------|---------|---------------|-------------|-------------------------|--------------|
| | RoHS Compliant | Non RoHS Compliant | | | | | |
| HCPL-314J | -000E | No option | SO-16 | X | | X | 45 per tube |
| | -500E | #500 | | X | X | X | 850 per reel |

To order, choose a part number from the part number column and combine with the desired option from the option column to form an order entry.

Example 1:

HCPL-314J-500E to order product of SO-16 Surface Mount package in Tape and Reel packaging with IEC/EN/DIN EN 60747-5-2 Safety Approval in RoHS compliant.

Example 2:

HCPL-314J to order product of SO-16 Surface Mount package in tube packaging with IEC/EN/DIN EN 60747-5-2 Safety Approval and non RoHS compliant.

Option datasheets are available. Contact your Avago sales representative or authorized distributor for information.

Remarks: The notation '#XXX' is used for existing products, while (new) products launched since 15th July 2001 and RoHS compliant option will use '-XXXE'.

Package Outline Drawing

HCPL-314J SO16 Package:

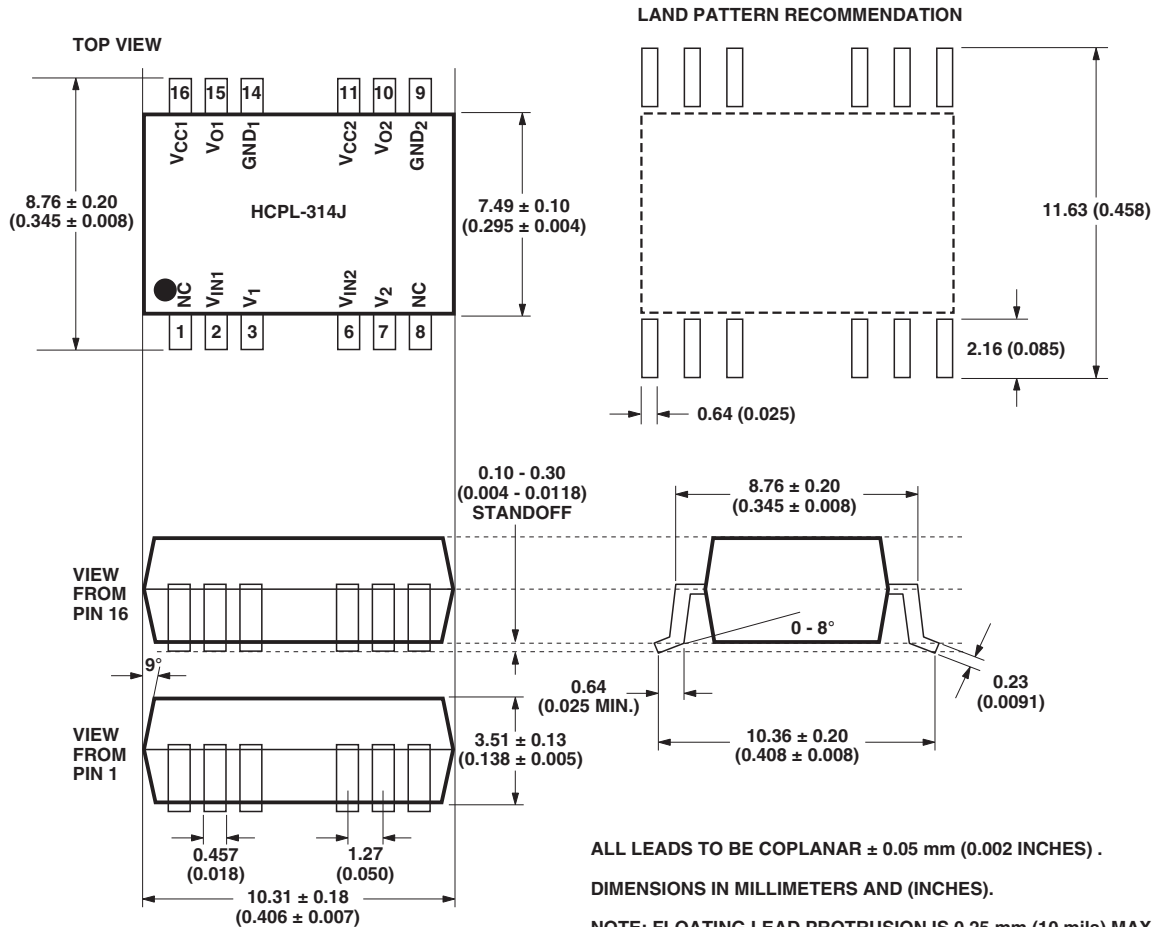

Recommended Pb-Free IR Profile

Recommended reflow condition as per JEDEC Standard, J-STD-020 (latest revision). Non-Halide Flux should be used.

Regulatory Information

The HCPL-314J has been approved by the following organizations:

IEC/EN/DIN EN 60747-5-2

Approved under:
IEC 60747-5-5:1997 + A1:2002
EN 60747-5-2:2001 + A1:2002
DIN EN 60747-5-2 (VDE 0884
Teil 2):2003-01.

UL

Approval under UL 1577, component recognition program up to $V_{ISO} = 5000 V_{rms}$. File E55361.

CSA

Approved under CSA Component Acceptance Notice #5, File CA 88324.

IEC/EN/DIN EN 60747-5-2 Insulation Characteristics

| Description | Symbol | Characteristic | Unit |
|---|-----------------|---------------------------------------|-------------|
| Installation classification per DIN VDE 0110/1.89, Table 1 for rated mains voltage $\leq 150 V_{rms}$ for rated mains voltage $\leq 300 V_{rms}$ for rated mains voltage $\leq 600 V_{rms}$ for rated mains voltage $\leq 1000 V_{rms}$ | | I - IV I - IV I - IV I - III | |
| Climatic Classification | | 55/100/21 | |
| Pollution Degree (DIN VDE 0110/1.89) | | 2 | |
| Maximum Working Insulation Voltage | V_{IORM} | 1230 | V_{peak} |
| Input to Output Test Voltage, Method b* $V_{IORM} \times 1.875 = V_{PR}$, 100% Production Test with $t_m = 1$ sec, Partial discharge < 5 pC | V_{PR} | 2306 | V_{peak} |
| Input to Output Test Voltage, Method a* $V_{IORM} \times 1.6 = V_{PR}$, Type and Sample Test, $t_m = 10$ sec, Partial discharge < 5 pC | V_{PR} | 1968 | V_{peak} |
| Highest Allowable Overvoltage (Transient Overvoltage $t_{ini} = 60$ sec) | V_{IOTM} | 8000 | V_{peak} |
| Safety-limiting values - maximum values allowed in the event of a failure. | | | |
| Case Temperature | T_S | 175 | $^{\circ}C$ |
| Input Current** | $I_{S, INPUT}$ | 400 | mA |
| Output Power** | $P_{S, OUTPUT}$ | 1200 | mW |
| Insulation Resistance at T_S , $V_{IO} = 500$ V | R_S | $> 10^9$ | Ω |

* Refer to the optocoupler section of the Isolation and Control Components Designer's Catalog, under Product Safety Regulations section, IEC/EN/DIN EN 60747-5-2, for a detailed description of Method a and Method b partial discharge test profiles.

** Refer to the following figure for dependence of P_S and I_S on ambient temperature.

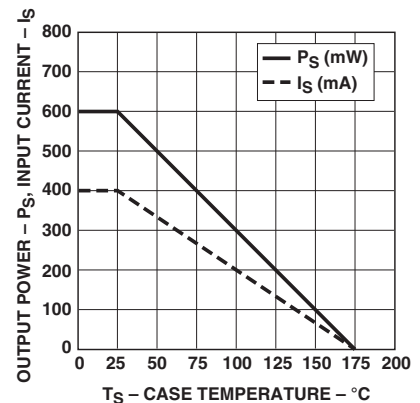

Insulation and Safety Related Specifications

| Parameter | Symbol | HCPL-314J | Units | Conditions |
|---|--------|-----------|-------|--|
| Minimum External Air Gap (Clearance) | L(101) | 8.3 | mm | Measured from input terminals to output terminals, shortest distance through air. |
| Minimum External Tracking (Creepage) | L(102) | 8.3 | mm | Measured from input terminals to output terminals, shortest distance path along body. |
| Minimum Internal Plastic Gap (Internal Clearance) | | 0.5 | mm | Through insulation distance conductor to conductor, usually the straight line distance thickness between the emitter and detector. |
| Tracking Resistance (Comparative Tracking Index) | CTI | >175 | V | DIN IEC 112/VDE 0303 Part 1 |
| Isolation Group | IIIa | | | Material Group (DIN VDE 0110, 1/89, Table 1) |

Absolute Maximum Ratings

| Parameter | Symbol | Min. | Max. | Units | Note |
|---|---|------|----------|-------|------|
| Storage Temperature | T_S | -55 | 125 | °C | |
| Operating Temperature | T_A | -40 | 100 | °C | |
| Average Input Current | $I_{F(AVG)}$ | | 25 | mA | 1 |
| Peak Transient Input Current (<1 μ s pulse width, 300pps) | $I_{F(TRAN)}$ | | 1.0 | A | |
| Reverse Input Voltage | V_R | | 5 | V | |
| “High” Peak Output Current | $I_{OH(PEAK)}$ | | 0.6 | A | 2 |
| “Low” Peak Output Current | $I_{OL(PEAK)}$ | | 0.6 | A | 2 |
| Supply Voltage | $V_{CC-V_{EE}}$ | -0.5 | 35 | V | |
| Output Voltage | $V_{O(PEAK)}$ | -0.5 | V_{CC} | V | |
| Output Power Dissipation | P_O | | 260 | mW | 3 |
| Input Power Dissipation | P_I | | 105 | mW | 4 |
| Lead Solder Temperature | 260°C for 10 sec., 1.6 mm below seating plane | | | | |
| Solder Reflow Temperature Profile | See Package Outline Drawings section | | | | |

Recommended Operating Conditions

| Parameter | Symbol | Min. | Max. | Units | Note |
|-----------------------|-----------------|------|------|-------|------|
| Power Supply | $V_{CC-V_{EE}}$ | 10 | 30 | V | |
| Input Current (ON) | $I_{F(ON)}$ | 8 | 12 | mA | |
| Input Voltage (OFF) | $V_{F(OFF)}$ | -3.6 | 0.8 | V | |
| Operating Temperature | T_A | -40 | 100 | °C | |

Electrical Specifications (DC)

Over recommended operating conditions unless otherwise specified.

| Parameter | Symbol | Min. | Typ. | Max. | Units | Test Conditions | Fig. | Note |
|---|----------------------------------|---------------------|-----------------------|------|-------|---|-------|------|
| High Level Output Current | I _{OH} | 0.2 | | | A | V _o = V _{CC} - 4 | 2 | 5 |
| | | | 0.4 | 0.5 | | V _o = V _{CC} - 10 | 3 | 2 |
| Low Level Output Current | I _{OL} | 0.2 | 0.4 | | A | V _o = V _{EE} + 2.5 | 5 | 5 |
| | | | 0.4 | 0.5 | | V _o = V _{EE} + 10 | 6 | 2 |
| High Level Output Voltage | V _{OH} | V _{CC} - 4 | V _{CC} - 1.8 | | V | I _o = -100 mA | 1 | 6, 7 |
| Low Level Output Voltage | V _{OL} | | 0.4 | 1 | V | I _o = 100 mA | 4 | |
| High Level Supply Current | I _{CCH} | | 0.7 | 3 | mA | I _o = 0 mA | 7, 8 | 15 |
| Low Level Supply Current | I _{CCL} | | 1.2 | 3 | mA | I _o = 0 mA | | |
| Threshold Input Current Low to High | I _{FLH} | | | 5 | mA | I _o = 0 mA, V _o > 5 V | 9, 15 | |
| Threshold Input Voltage High to Low | V _{FHL} | 0.8 | | | V | | | |
| Input Forward Voltage | V _F | 1.2 | 1.5 | 1.8 | V | I _F = 10 mA | 16 | |
| Temperature Coefficient of Input Forward Voltage | ΔV _F /ΔT _A | | -1.2 | | mV/°C | | | |
| Input Reverse Breakdown Voltage | BV _R | 3 | 10 | | V | I _R = 100 μA | | |
| Input Capacitance | C _{IN} | | 70 | | pF | f = 1 MHz, V _F = 0 V | | |

Switching Specifications (AC)

Over recommended operating conditions unless otherwise specified.

| Parameter | Symbol | Min. | Typ. | Max. | Units | Test Conditions | Fig. | Note |
|--|------------------|------|------|------|-------|--|--------------------|-----------|
| Propagation Delay Time to High Output Level | t _{PLH} | 0.1 | 0.2 | 0.7 | μs | R _g = 47 Ω, C _g = 3 nF, f = 10 kHz, Duty Cycle = 50%, I _F = 8 mA, V _{CC} = 30 V | 10, 11, 12, 13, | 14 |
| Propagation Delay Time to Low Output Level | t _{PHL} | 0.1 | 0.3 | 0.7 | μs | | 14, 17 | |
| Propagation Delay Difference Between Any Two Parts or Channels | PDD | -0.5 | | 0.5 | μs | | | 10 |
| Rise Time | t _R | | 50 | | ns | | | |
| Fall Time | t _F | | 50 | | ns | | | |
| Output High Level Common Mode Transient Immunity | CM _H | 25 | 35 | | kV/μs | T _A = 25°C, V _{CM} = 1.5 kV | 18 | 11, 12 |
| Output Low Level Common Mode Transient Immunity | CM _L | 25 | 35 | | kV/μs | | 18 | 11, 13 |

Package Characteristics

For each channel unless otherwise specified.

| Parameter | Symbol | Min. | Typ. | Max. | Units | Test Conditions | Fig. | Note |
|---|-----------|------|-----------|------|----------|--|------|------|
| Input-Output Momentary Withstand Voltage | V_{ISO} | 5000 | | | Vrms | $T_A=25^{\circ}\text{C}$, $\text{RH}<50\%$ for 1 min. | | 8,9 |
| Output-Output Momentary Withstand Voltage | V_{O-O} | 1500 | | | Vrms | | | 16 |
| Input-Output Resistance | R_{I-O} | | 10^{12} | | Ω | $V_{I-O}=500\text{V}$ | | 9 |
| Input-Output Capacitance | C_{I-O} | | 1.2 | | pF | Freq=1 MHz | | |

Notes:

- Derate linearly above 70°C free air temperature at a rate of 0.3 mA/°C.
- Maximum pulse width = 10 μs , maximum duty cycle = 0.2%. This value is intended to allow for component tolerances for designs with I_O peak minimum = 0.4 A. See Application section for additional details on limiting I_{OL} peak.
- Derate linearly above 85°C, free air temperature at the rate of 4.0 mW/°C.
- Input power dissipation does not require derating.
- Maximum pulse width = 50 μs , maximum duty cycle = 0.5%.
- In this test, V_{OH} is measured with a DC load current. When driving capacitive load V_{OH} will approach V_{CC} as I_{OH} approaches zero amps.
- Maximum pulse width = 1 ms, maximum duty cycle = 20%.
- In accordance with UL 1577, each HCPL-314J optocoupler is proof tested by applying an insulation test voltage $\geq 6000 V_{rms}$ for 1 second. This test is performed before 100% production test for partial discharge (method B) shown in the IEC/EN/DIN EN 60747-5-2 Insulation Characteristics Table, if applicable.
- Device considered a two-terminal device: pins on input side shorted together and pins on output side shorted together.
- PDD is the difference between t_{PHL} and t_{PLH} between any two parts or channels under the same test conditions.
- Pins 3 and 4 (HCPL-314J) need to be connected to LED common.
- Common mode transient immunity in the high state is the maximum tolerable $|dV_{CM}/dt|$ of the common mode pulse V_{CM} to assure that the output will remain in the high state (i.e. $V_O > 6.0\text{V}$).
- Common mode transient immunity in a low state is the maximum tolerable $|dV_{CM}/dt|$ of the common mode pulse, V_{CM} , to assure that the output will remain in a low state (i.e. $V_O < 1.0\text{V}$).
- This load condition approximates the gate load of a 1200 V/25 A IGBT.
- For each channel. The power supply current increases when operating frequency and Q_g of the driven IGBT increases.
- Device considered a two terminal device: Channel one output side pins shorted together, and channel two output side pins shorted together.

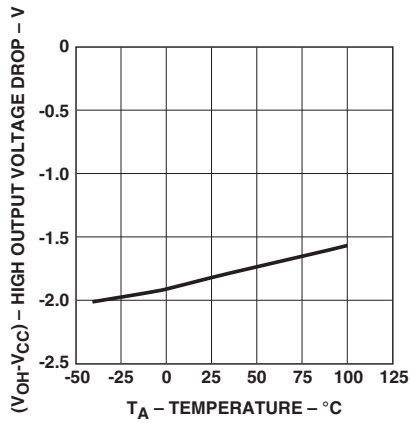

Figure 1. V_{OH} vs. Temperature.

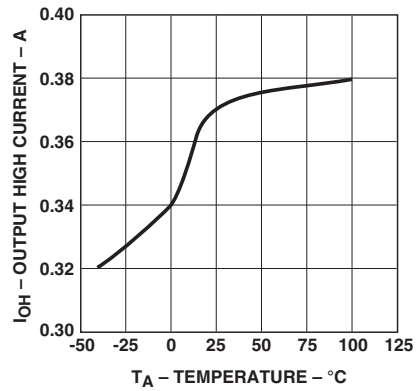

Figure 2. I_{OH} vs. Temperature.

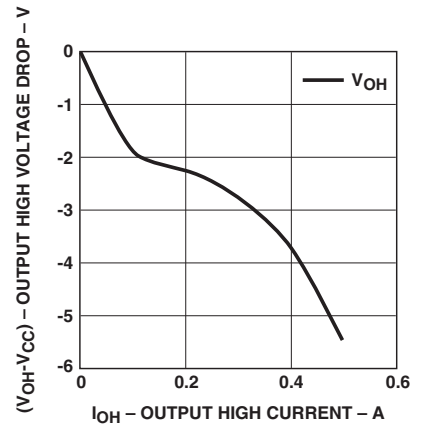

Figure 3. V_{OH} vs. I_{OH} .

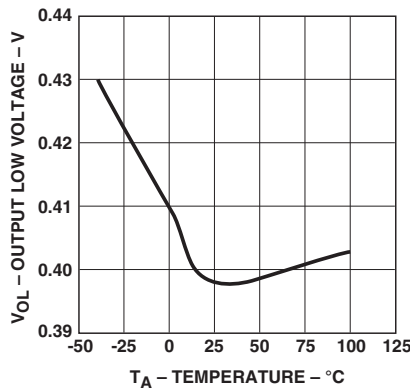

Figure 4. V_{OL} vs. Temperature.

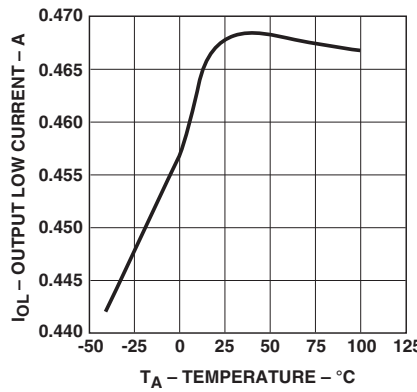

Figure 5. I_{OL} vs. Temperature.

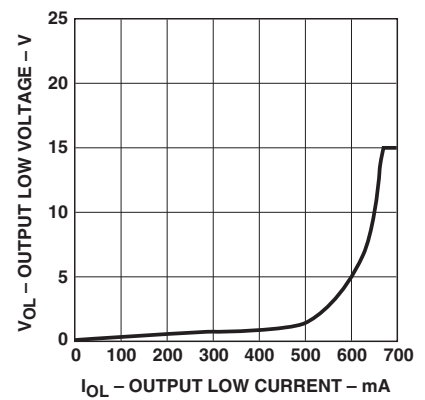

Figure 6. V_{OL} vs. I_{OL} .

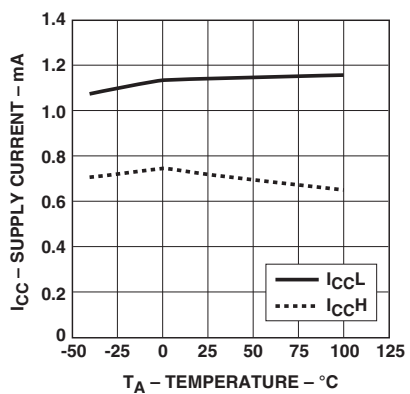

Figure 7. I_{CC} vs. Temperature.

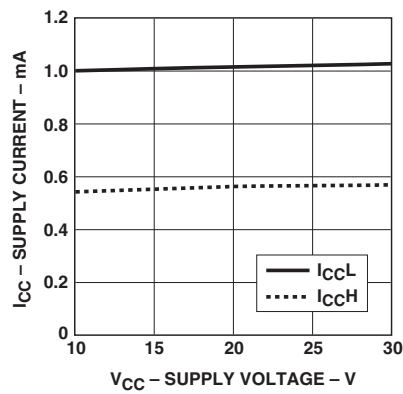

Figure 8. I_{CC} vs. V_{CC} .

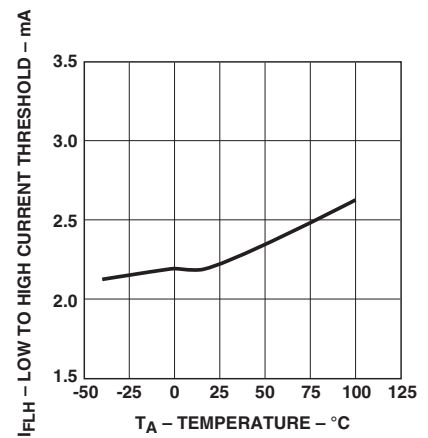

Figure 9. I_{FLH} vs. Temperature.

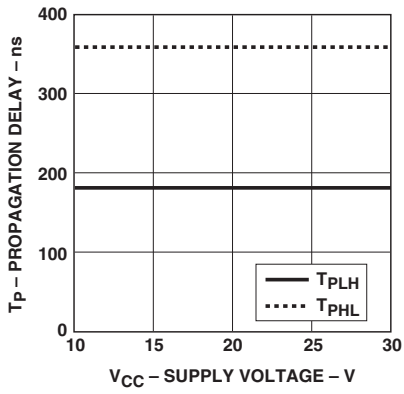

Figure 10. Propagation Delay vs. V_{CC} .

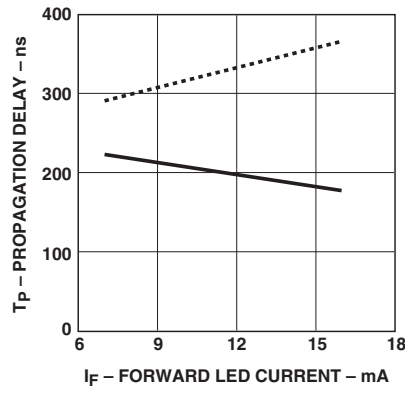

Figure 11. Propagation Delay vs. I_f .

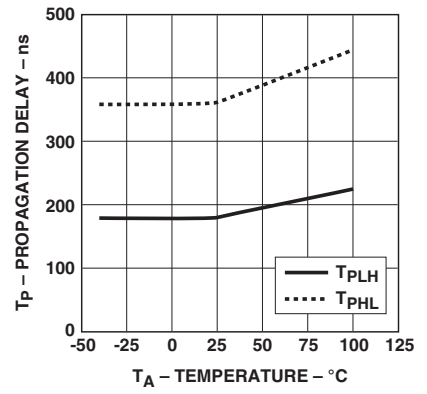

Figure 12. Propagation Delay vs. Temperature.

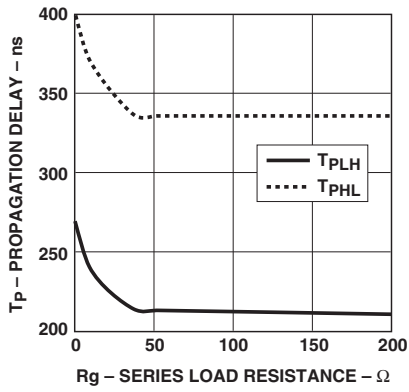

Figure 13. Propagation Delay vs. R_g .

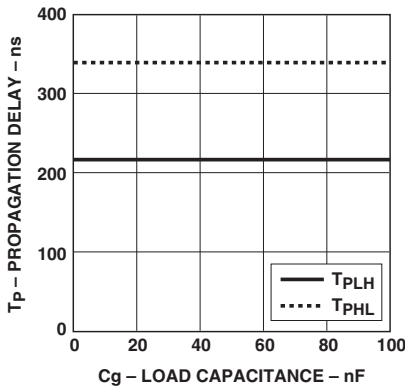

Figure 14. Propagation Delay vs. C_g .

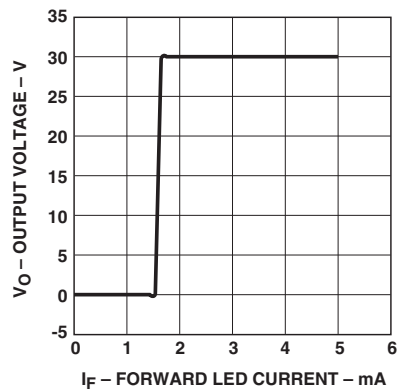

Figure 15. Transfer Characteristics.

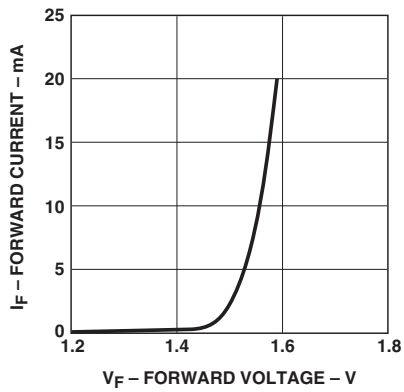

Figure 16. Input Current vs. Forward Voltage.

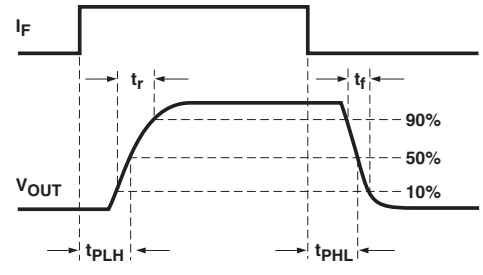
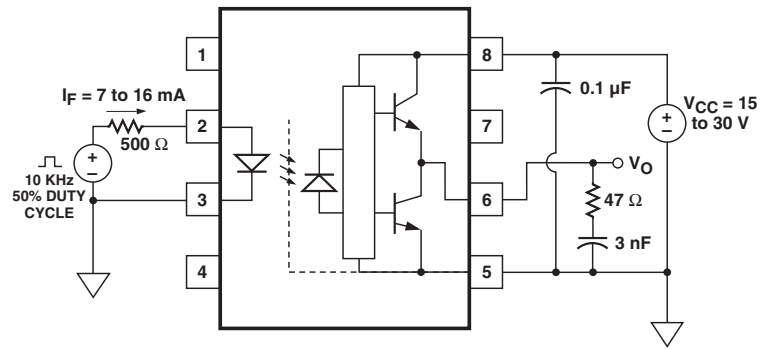

Figure 17. Propagation Delay Test Circuit and Waveforms.

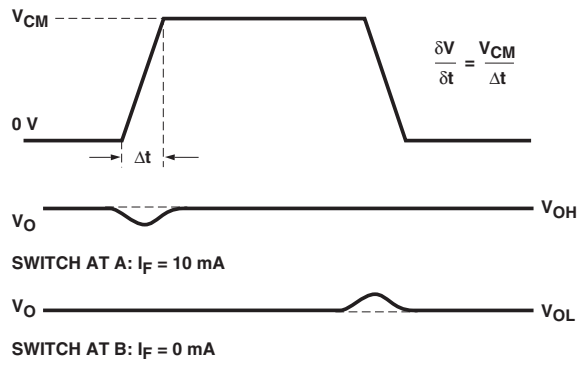
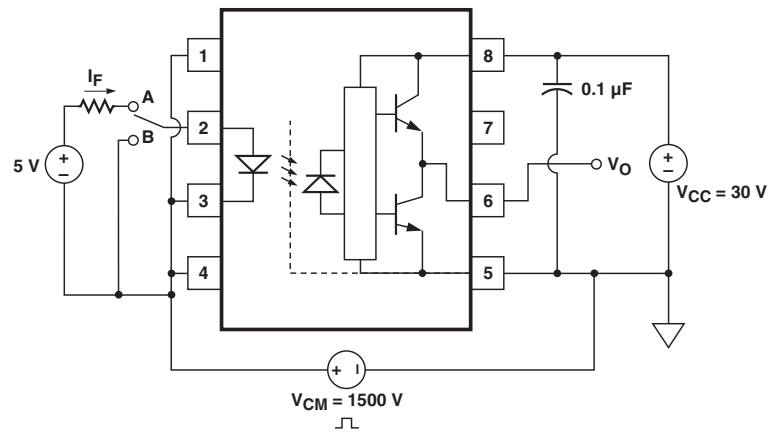

Figure 18. CMR Test Circuit and Waveforms.

Applications Information

Eliminating Negative IGBT Gate Drive

To keep the IGBT firmly off, the HCPL-314J has a very low maximum V_{OL} specification of 1.0 V. Minimizing R_g and the lead inductance from the HCPL-314J to the IGBT gate and emitter (possibly by mounting the HCPL-314J on a small PC board directly above the IGBT) can eliminate the need for negative IGBT gate drive in many applications as shown in Figure 19. Care should be taken with such a PC board design to avoid routing the IGBT collector or emitter traces close to the HCPL-314J input as this can result in unwanted coupling of transient signals into

the input of HCPL-314J and degrade performance. (If the IGBT drain must be routed near the HCPL-314J input, then the LED should be reverse biased when in the off state, to prevent the transient signals coupled from the IGBT drain from turning on the HCPL-314J.) An external clamp diode may be connected between pins 14 & 15 and pins 9 & 10 (as shown in Figure 19) for the protection of HCPL-314J in the case of IGBTs switching inductive load.

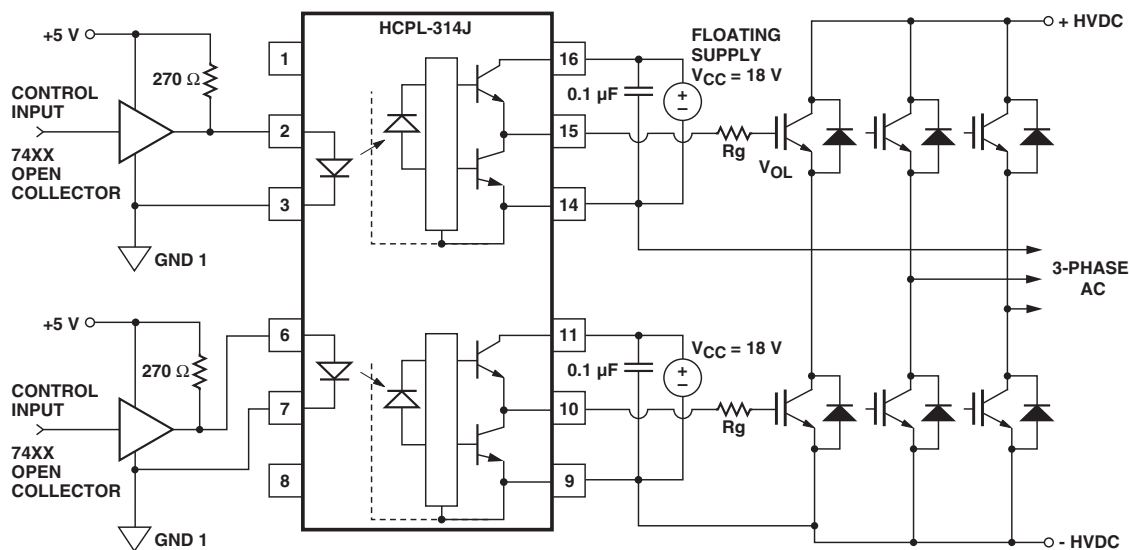

Figure 19. Recommended LED Drive and Application Circuit for HCPL-314J.

Selecting the Gate Resistor (Rg)

Step 1: Calculate Rg minimum from the IOL peak specification. The IGBT and Rg in Figure 24 can be analyzed as a simple RC circuit with a voltage supplied by the HCPL-314J.

$$\begin{aligned} R_g &\geq \frac{V_{CC} - V_{OL}}{I_{OLPEAK}} \\ &= \frac{24\text{ V} - 5\text{ V}}{0.6\text{ A}} \\ &= 32\ \Omega \end{aligned}$$

The VOL value of 5 V in the previous equation is the VOL at the peak current of 0.6A. (See Figure 6).

Step 2: Check the HCPL-314J power dissipation and increase Rg if necessary. The HCPL-314J total power dissipation (PT) is equal to the sum of the emitter power (PE) and the output power (PO).

$$P_T = P_E + P_O$$

$$P_E = I_F \cdot V_F \cdot \text{Duty Cycle}$$

$$\begin{aligned} P_O &= P_{O(BIAS)} + P_{O(SWITCHING)} = I_{CC} \cdot V_{CC} + E_{SW}(R_g, Q_g) \cdot f \\ &= (I_{CCBIAS} + K_{ICC} \cdot Q_g \cdot f) \cdot V_{CC} + E_{SW}(R_g, Q_g) \cdot f \end{aligned}$$

where $K_{ICC} \cdot Q_g \cdot f$ is the increase in ICC due to switching and KICC is a constant of 0.001 mA/(nC*kHz). For the circuit in Figure 19 with IF (worst case) = 10 mA, Rg = 32 Ω, Max Duty Cycle = 80%, Qg = 100 nC, f = 20 kHz and TAMAX = 85°C:

$$P_E = 10\text{ mA} \cdot 1.8\text{ V} \cdot 0.8 = 14\text{ mW}$$

$$\begin{aligned} P_O &= (3\text{ mA} + (0.001\text{ mA}/(\text{nC} \cdot \text{kHz})) \cdot 20\text{ kHz} \cdot 100\text{ nC}) \cdot 24\text{ V} + 0.4\ \mu\text{J} \cdot 20\text{ kHz} \\ &= 128\text{ mW} \end{aligned}$$

$$< 260\text{ mW } (P_{O(MAX)} \text{ @ } 85^\circ\text{C})$$

The value of 3 mA for ICC in the previous equation is the max. ICC over entire operating temperature range.

Since PO for this case is less than PO(MAX), Rg = 32 Ω is alright for the power dissipation.

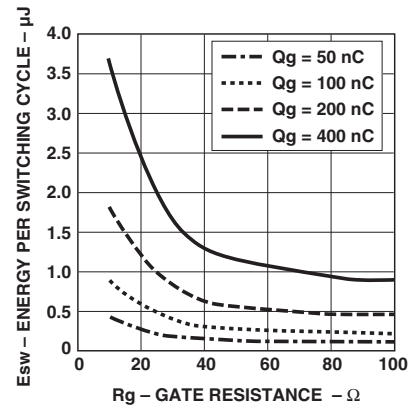

Figure 20. Energy Dissipated in the HCPL-314J and for Each IGBT Switching Cycle.

LED Drive Circuit Considerations for Ultra High CMR Performance

Without a detector shield, the dominant cause of optocoupler CMR failure is capacitive coupling from the input side of the optocoupler, through the package, to the detector IC as shown in Figure 21. The HCPL-314J improves CMR performance by using a detector IC with an optically transparent Faraday shield, which diverts the capacitively coupled current away from the sensitive IC circuitry. However, this shield does not eliminate the capacitive coupling between the LED and optocoupler pins 5-8 as shown in Figure 22. This capacitive coupling causes perturbations in the LED current during common mode transients and becomes the major source of CMR failures for a shielded optocoupler. The main design objective of a high CMR LED drive circuit becomes keeping the LED in the proper state (on or off) during common mode transients. For example, the recommended application circuit (Figure 19), can achieve 10 kV/μs CMR while minimizing component complexity.

Techniques to keep the LED in the proper state are discussed in the next two sections.

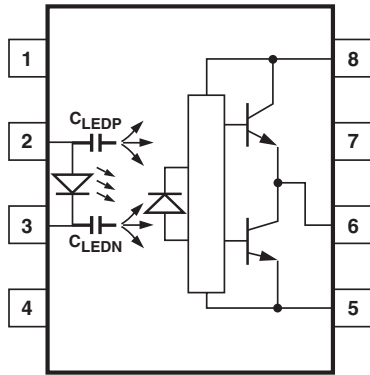

Figure 21. Optocoupler Input to Output Capacitance Model for Unshielded Optocouplers.

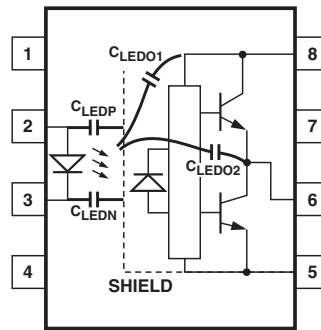

Figure 22. Optocoupler Input to Output Capacitance Model for Shielded Optocouplers.

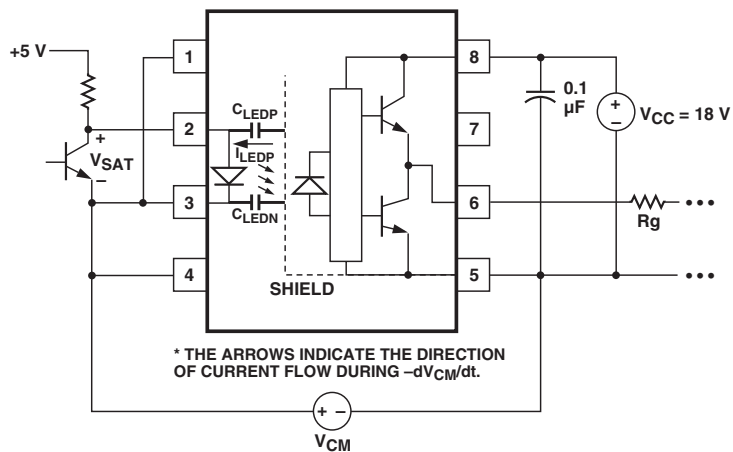

Figure 23. Equivalent Circuit for Figure 17 During Common Mode Transient.

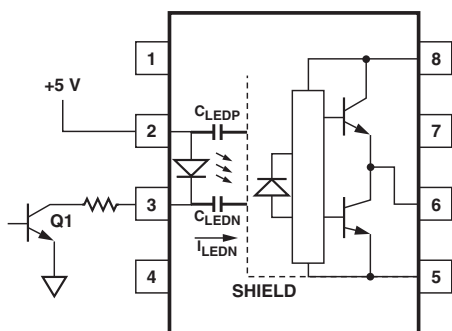

Figure 24. Not Recommended Open Collector Drive Circuit.

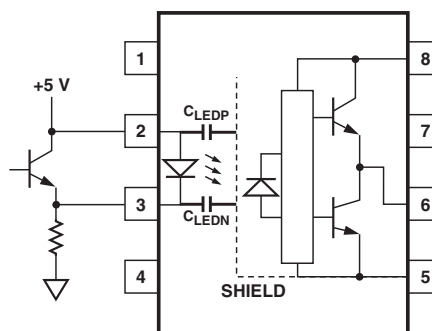

Figure 25. Recommended LED Drive Circuit for Ultra-High CMR IPM Dead Time and Propagation Delay Specifications.

CMR with the LED On (CMR_H)

A high CMR LED drive circuit must keep the LED on during common mode transients. This is achieved by overdriving the LED current beyond the input threshold so that it is not pulled below the threshold during a transient. A minimum LED current of 8 mA provides adequate margin over the maximum I_{FLH} of 5 mA to achieve 10 kV/μs CMR.

CMR with the LED Off (CMR_L)

A high CMR LED drive circuit must keep the LED off ($V_F \leq V_{F(OFF)}$) during common mode transients. For example, during a $-dV_{CM}/dt$ transient in Figure 23, the current flowing through C_{LEDP} also flows through the R_{SAT} and V_{SAT} of the logic gate. As long as the low state voltage developed across the logic gate is less than V_{F(OFF)} the LED will remain off and no common mode failure will occur.

The open collector drive circuit, shown in Figure 24, can not keep the LED off during a $+dV_{CM}/dt$ transient, since all the current flowing through C_{LEDN} must be supplied by the LED, and it is not recommended for applications requiring ultra high CMR₁ performance. The alternative drive circuit which like the recommended application circuit (Figure 19), does achieve ultra high CMR performance by shunting the LED in the off state.

IPM Dead Time and Propagation Delay Specifications

The HCPL-314J includes a Propagation Delay Difference (PDD) specification intended to help designers minimize “dead time” in their power inverter designs. Dead time is the time high and low side power transistors are off. Any overlap in Q1 and Q2 conduction will result in large currents flowing through the power devices from the high-voltage to the low-voltage motor rails. To minimize dead time in a given design, the turn on of LED2 should be delayed (relative to the turn off of LED1) so that under worst-case conditions, transistor Q1 has just turned off when transistor Q2 turns on, as shown in Figure 26. The amount of delay necessary to achieve this condition is equal to the maximum value of the propagation delay difference specification, PDD_{max}, which is specified to be 500 ns over the operating temperature range of -40° to 100°C .

Delaying the LED signal by the maximum propagation delay difference ensures that the minimum dead time is zero, but it does not tell a designer what the maximum dead time will be. The maximum dead time is equivalent to the difference between the maximum and minimum propagation delay difference specification as shown in Figure 27. The maximum dead time for the HCPL-314J is 1 μs (= 0.5 μs - (-0.5 μs)) over the operating temperature range of -40°C to 100°C .

Note that the propagation delays used to calculate PDD and dead time are taken at equal temperatures and test conditions since the optocouplers under consideration are typically mounted in close proximity to each other and are switching identical IGBTs.

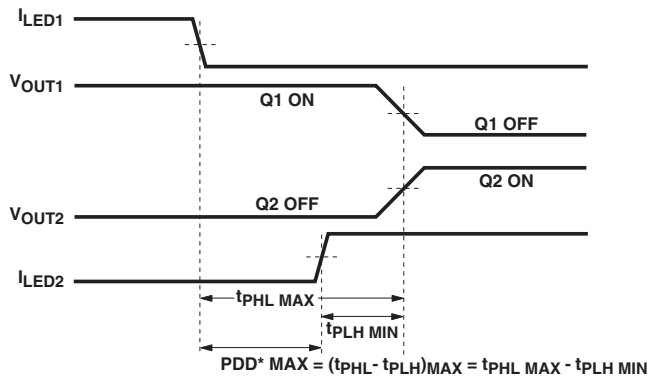

*PDD = PROPAGATION DELAY DIFFERENCE
 NOTE: FOR PDD CALCULATIONS THE PROPAGATION DELAYS ARE TAKEN AT THE SAME TEMPERATURE AND TEST CONDITIONS.

Figure 26. Minimum LED Skew for Zero Dead Time.

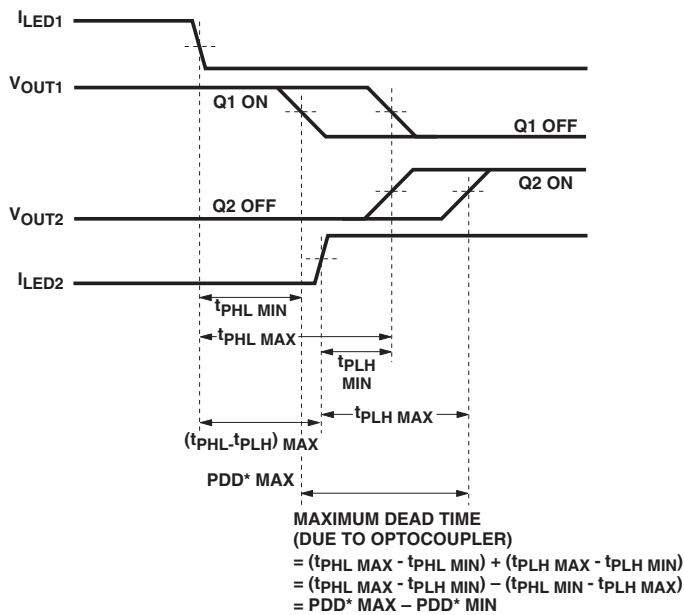

*PDD = PROPAGATION DELAY DIFFERENCE
 NOTE: FOR DEAD TIME AND PDD CALCULATIONS ALL PROPAGATION DELAYS ARE TAKEN AT THE SAME TEMPERATURE AND TEST CONDITIONS.

Figure 27. Waveforms for Dead Time.

For product information and a complete list of distributors, please go to our website: www.avagotech.com

Avago, Avago Technologies, and the A logo are trademarks of Avago Technologies in the United States and other countries. Data subject to change. Copyright © 2005-2011 Avago Technologies. All rights reserved. Obsoletes 5989-2943EN AV02-0169EN - March 28, 2011





Компания «ЭлектроПласт» предлагает заключение долгосрочных отношений при поставках импортных электронных компонентов на взаимовыгодных условиях!

Наши преимущества:

- Оперативные поставки широкого спектра электронных компонентов отечественного и импортного производства напрямую от производителей и с крупнейших мировых складов;
- Поставка более 17-ти миллионов наименований электронных компонентов;
- Поставка сложных, дефицитных, либо снятых с производства позиций;
- Оперативные сроки поставки под заказ (от 5 рабочих дней);
- Экспресс доставка в любую точку России;
- Техническая поддержка проекта, помощь в подборе аналогов, поставка прототипов;
- Система менеджмента качества сертифицирована по Международному стандарту ISO 9001;
- Лицензия ФСБ на осуществление работ с использованием сведений, составляющих государственную тайну;
- Поставка специализированных компонентов (Xilinx, Altera, Analog Devices, Intersil, Interpoint, Microsemi, Aeroflex, Peregrine, Syfer, Eurofarad, Texas Instrument, Miteq, Cobham, E2V, MA-COM, Hittite, Mini-Circuits, General Dynamics и др.);

Помимо этого, одним из направлений компании «ЭлектроПласт» является направление «Источники питания». Мы предлагаем Вам помощь Конструкторского отдела:

- Подбор оптимального решения, техническое обоснование при выборе компонента;
- Подбор аналогов;
- Консультации по применению компонента;
- Поставка образцов и прототипов;
- Техническая поддержка проекта;
- Защита от снятия компонента с производства.



Как с нами связаться

Телефон: 8 (812) 309 58 32 (многоканальный)

Факс: 8 (812) 320-02-42

Электронная почта: org@eplast1.ru

Адрес: 198099, г. Санкт-Петербург, ул. Калинина, дом 2, корпус 4, литера А.