

Description

The PAM2800 is a high power white LED driver with 350mA constant rated source current. It features high efficiency and low quiescent current, making it ideal for battery powered applications.

Features

- High Efficiency 92%
- Up to 350mA Constant Source Current
- Low Quiescent Current: Typ. 65µA
- 0.5µA Shutdown Current
- Short Circuit Protection
- Open Load LED Protection
- Thermal Protection
- Space Saving Package SOT23-5
- Pb-Free Package

Pin Assignments

Top View
SOT23-5

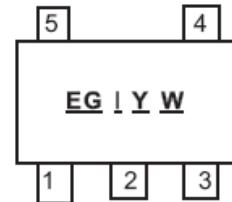

Applications

- High Power White LED Driver

Typical Applications Circuit

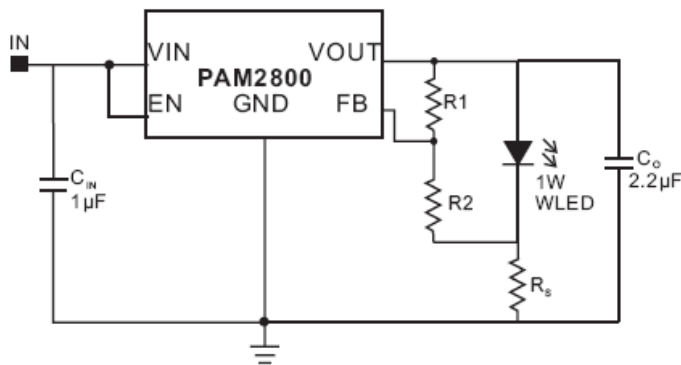
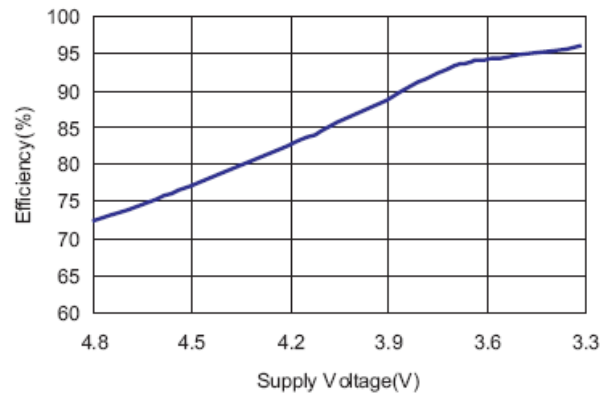

Figure 1



Pin Description

Pin Number	Pin Name	Function
1	VIN	Input
2	GND	Ground
3	EN	Chip Enable (Active High)
4	FB	Feedback
5	VOUT	Output

Absolute Maximum Ratings (@T_A = +25°C, unless otherwise specified.)

These are stress ratings only and functional operation is not implied. Exposure to absolute maximum ratings for prolonged time periods may affect device reliability. All voltages are with respect to ground.

Parameter	Rating	Unit
Input Voltage	6	V
Output Current	350	mA
Output Pin Voltage	GND -0.3 to V _{IN} +0.3	V
Lead Soldering Temperature	300, (5sec)	°C
Storage Temperature	-65 to +150	°C

Recommended Operating Conditions (@T_A = +25°C, unless otherwise specified.)

Parameter	Rating	Unit
Maximum Supply Voltage	5.5	V
Junction Temperature	-40 to +125	°C
Operation Temperature	-40 to +85	

Thermal Information

Parameter	Symbol	Package	Max	Unit
Thermal Resistance (Junction to Case)	θ_{JC}	SOT23-5	130	°C/W
Thermal Resistance (Junction to Ambient)	θ_{JA}	SOT23-5	250	
Internal Power Dissipation	P _D	SOT23-5	400	mW

Electrical Characteristics (@T_A = +25°C, V_{IN} = 3.7V, C_{IN} = 1μF, C_O = 2.2μF, unless otherwise specified.)

Parameter	Symbol	Test Conditions	Min	Typ	Max	Units
Input Voltage	V _{IN}				5.5	V
Output Current	I _O		300			mA
Quiescent Current	I _Q	No Load		65	90	μA
Efficiency			90	92		%
Over Temperature Shutdown	OTS	I _O = 1mA		150		°C
Over Temperature Hysteresis	OTH	I _O = 1mA		30		°C

Typical Performance Characteristics

(@ $T_A = +25^\circ\text{C}$, $C_{IN} = 1\mu\text{F}$, $C_O = 2.2\mu\text{F}$, $R1 = 62\text{k}\Omega$, $R2 = 33\text{k}\Omega$, $R_S = 0.22\Omega$, unless otherwise specified.)

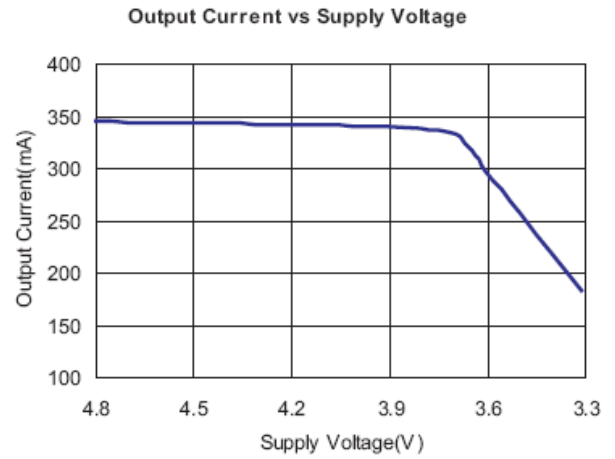
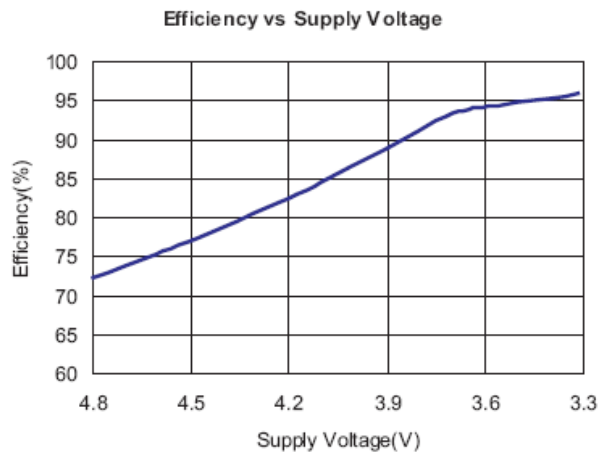

Application Information

In the typical application (see Figure 1), the LED current will come to constant current level little by little after the device is powered. A 62K Ω resistor is recommended for R1, the value for R2 should be adjusted around 33K Ω due to LED forward voltage from lot-to-lot or brand-to-brand.

Power Dissipation and Thermal Consideration

Thermal protection limits power dissipation in the PAM2800. When the operation junction temperature exceeds +150°C, the OTP (Over Temperature Protection) starts the thermal shutdown and turns the pass transistor off. The pass transistor resumes operation after the junction temperature drops below +120°C.

For continuous operation, the junction temperature should be maintained below +125°C. The power dissipation is defined as:

$$P_D = (V_{IN} - V_{OUT}) * I_O + V_{IN} * I_{GND}$$

The maximum power dissipation depends on the thermal resistance of IC package, PCB layout, the rate of surrounding airflow and temperature difference between junction and ambient. The maximum power dissipation can be calculated by the following formula:

$$P_{D(MAX)} = (T_{J(MAX)} - T_A) / \theta_{JA}$$

Where $T_{J(MAX)}$ is the maximum operation junction temperature +125°C. T_A is the ambient temperature, and θ_{JA} is the thermal resistance from the junction to the ambient.

For example, as θ_{JA} is +250°C/W for SOT-23, based on the standard JEDEC 51-3 for a single layer thermal test board, the maximum power dissipation for SOT-23 package at $T_A = +25^\circ\text{C}$ can be calculated by following formula:

$$P_{D(MAX)} = (125^\circ\text{C} - 25^\circ\text{C}) / 250 = 0.4\text{W}$$

To calculate the junction temperature of the PAM2800 SOT-23 package, if we use input voltage $V_{IN} = 4\text{V}$ at an output current $I_O = 300\text{mA}$ and the case temperature $T_A = 40^\circ\text{C}$ measured by the thermal couple while operating, the power dissipation is defined as:

$$P_D = (4\text{V} - 2.8\text{V}) * 300\text{mA} + 4\text{V} * 70\mu\text{A} \approx 360\text{mW}$$

Ordering Information

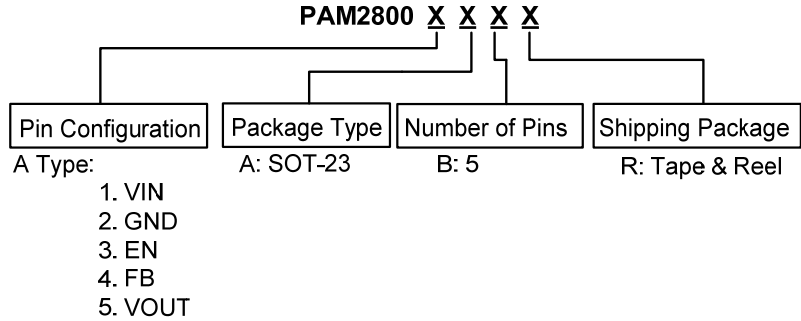

Part Number	Output Current	Marking	Package Type	Standard Package
PAM2800AABR	350mA	EGAYW	SOT23-5	3000 Units/Tape&Reel

Marking Information

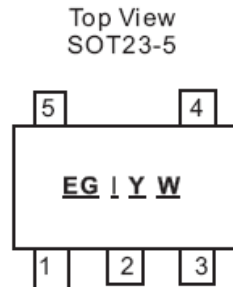

EG: Product Code of PAM2800
I: Current Code
Y: Year
W: Week

Package Outline Dimensions (All dimensions in mm.)

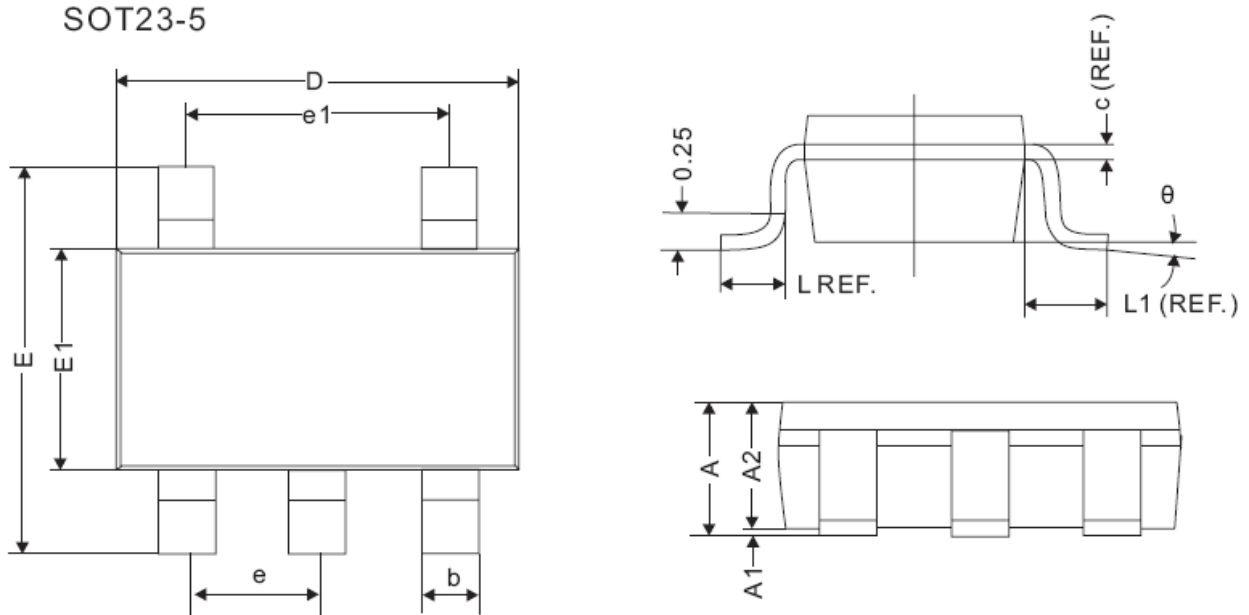

REF.	Millimeter	
	Min	Max
A	1.10MAX	
A1	0	0.10
A2	0.70	1
c	0.12REF.	
D	2.70	3.10
E	2.60	3.00
E1	1.40	1.80
L	0.45REF.	
L1	0.60REF.	
θ	0°	10°
b	0.30	0.50
e	0.95REF.	
e1	1.90REF.	

IMPORTANT NOTICE

DIODES INCORPORATED MAKES NO WARRANTY OF ANY KIND, EXPRESS OR IMPLIED, WITH REGARDS TO THIS DOCUMENT, INCLUDING, BUT NOT LIMITED TO, THE IMPLIED WARRANTIES OF MERCHANTABILITY AND FITNESS FOR A PARTICULAR PURPOSE (AND THEIR EQUIVALENTS UNDER THE LAWS OF ANY JURISDICTION).

Diodes Incorporated and its subsidiaries reserve the right to make modifications, enhancements, improvements, corrections or other changes without further notice to this document and any product described herein. Diodes Incorporated does not assume any liability arising out of the application or use of this document or any product described herein; neither does Diodes Incorporated convey any license under its patent or trademark rights, nor the rights of others. Any Customer or user of this document or products described herein in such applications shall assume all risks of such use and will agree to hold Diodes Incorporated and all the companies whose products are represented on Diodes Incorporated website, harmless against all damages.

Diodes Incorporated does not warrant or accept any liability whatsoever in respect of any products purchased through unauthorized sales channel.

Should Customers purchase or use Diodes Incorporated products for any unintended or unauthorized application, Customers shall indemnify and hold Diodes Incorporated and its representatives harmless against all claims, damages, expenses, and attorney fees arising out of, directly or indirectly, any claim of personal injury or death associated with such unintended or unauthorized application.

Products described herein may be covered by one or more United States, international or foreign patents pending. Product names and markings noted herein may also be covered by one or more United States, international or foreign trademarks.

This document is written in English but may be translated into multiple languages for reference. Only the English version of this document is the final and determinative format released by Diodes Incorporated.

LIFE SUPPORT

Diodes Incorporated products are specifically not authorized for use as critical components in life support devices or systems without the express written approval of the Chief Executive Officer of Diodes Incorporated. As used herein:

A. Life support devices or systems are devices or systems which:

1. are intended to implant into the body, or
2. support or sustain life and whose failure to perform when properly used in accordance with instructions for use provided in the labeling can be reasonably expected to result in significant injury to the user.

B. A critical component is any component in a life support device or system whose failure to perform can be reasonably expected to cause the failure of the life support device or to affect its safety or effectiveness.

Customers represent that they have all necessary expertise in the safety and regulatory ramifications of their life support devices or systems, and acknowledge and agree that they are solely responsible for all legal, regulatory and safety-related requirements concerning their products and any use of Diodes Incorporated products in such safety-critical, life support devices or systems, notwithstanding any devices- or systems-related information or support that may be provided by Diodes Incorporated. Further, Customers must fully indemnify Diodes Incorporated and its representatives against any damages arising out of the use of Diodes Incorporated products in such safety-critical, life support devices or systems.

Copyright © 2012, Diodes Incorporated

www.diodes.com



Компания «ЭлектроПласт» предлагает заключение долгосрочных отношений при поставках импортных электронных компонентов на взаимовыгодных условиях!

Наши преимущества:

- Оперативные поставки широкого спектра электронных компонентов отечественного и импортного производства напрямую от производителей и с крупнейших мировых складов;
- Поставка более 17-ти миллионов наименований электронных компонентов;
- Поставка сложных, дефицитных, либо снятых с производства позиций;
- Оперативные сроки поставки под заказ (от 5 рабочих дней);
- Экспресс доставка в любую точку России;
- Техническая поддержка проекта, помощь в подборе аналогов, поставка прототипов;
- Система менеджмента качества сертифицирована по Международному стандарту ISO 9001;
- Лицензия ФСБ на осуществление работ с использованием сведений, составляющих государственную тайну;
- Поставка специализированных компонентов (Xilinx, Altera, Analog Devices, Intersil, Interpoint, Microsemi, Aeroflex, Peregrine, Syfer, Eurofarad, Texas Instrument, Miteq, Cobham, E2V, MA-COM, Hittite, Mini-Circuits, General Dynamics и др.);

Помимо этого, одним из направлений компании «ЭлектроПласт» является направление «Источники питания». Мы предлагаем Вам помощь Конструкторского отдела:

- Подбор оптимального решения, техническое обоснование при выборе компонента;
- Подбор аналогов;
- Консультации по применению компонента;
- Поставка образцов и прототипов;
- Техническая поддержка проекта;
- Защита от снятия компонента с производства.



Как с нами связаться

Телефон: 8 (812) 309 58 32 (многоканальный)

Факс: 8 (812) 320-02-42

Электронная почта: org@eplast1.ru

Адрес: 198099, г. Санкт-Петербург, ул. Калинина, дом 2, корпус 4, литера А.