

# LT1999: High Voltage, Bidirectional Current Sense Amplifier

## DESCRIPTION

Demonstration circuit 1698A features the LT1999, a high voltage, bi-directional current sense amplifier.

The demo board amplifies the voltage drop across an on board current sense resistor. The output voltage is a bi-directional signal that is centered on the  $V_{REF}$  voltage and is proportional to the current through the sense resistor. The output is scaled by one of three fixed gain options. The gain options are: 10V/V (DC1698A-A), 20V/V (DC1698A-B)

and 50V/V (DC1698A-C). The input voltage range is from -5V to 80V (independent of the device supply voltage) allowing the part to be used for high or low side current sensing. The LT1999 requires a separate 5V supply voltage.

**Design files for this circuit board are available at <http://www.linear.com/demo>**

LT, LT, LTC, LTM, Linear Technology and the Linear logo are registered trademarks of Linear Technology Corporation. All other trademarks are the property of their respective owners.

## PERFORMANCE SUMMARY

**Table 1. Performance Summary ( $T_A = 25^\circ\text{C}$ )**

SYMBOL	PARAMETER	CONDITIONS	MIN	TYP	MAX	UNITS
$V_S$	Supply Range		4.5		5.5	V
$V_{CM}$	CM Input Voltage Range		-5		80	V
CMRR	Common Mode Rejection Ratio	$V_{CM} = 0V$ , $7V_{P-P}$ , $f = 100\text{kHz}$	80	100		dB
$V_{OUT}$	Swing Output High (with Respect to $V^+$ ) Swing Output Low (with Respect to $V^-$ )	$R_{LOAD} = \text{Open}$ $R_{LOAD} = \text{Open}$		5 150	125 225	mV mV
$V_{OSI}$	Input Referred Offset Voltage	$T_A = 25^\circ\text{C}$ , $V_{CM} > 5.5V$		550		$\mu\text{V}$
$I_Q$	$V^+$ Quiescent Current	$V_{CM} > 5.5V$		1.55		mA
$V_{REF}$	Open Circuit Voltage	$V_S = 5V$	2.44	2.5	2.55	V
$V_{REFIN}$	REF Pin Input Range		1.25		$V^+ - 1.5$	V

## OPERATING PRINCIPLES

The LT1999 operates by amplifying the voltage drop across a user selected sense resistor. The voltage across the resistor is amplified by a fixed gain of 10V/V, 20V/V or 50V/V (LT1999-10, LT1999-20, LT1999-50) and is level

shifted to the OUT pin of the device. The voltage difference and polarity with respect to the  $V_{REF}$  pin voltage indicates the magnitude and direction of the current in the sense resistor.

## BLOCK DIAGRAM

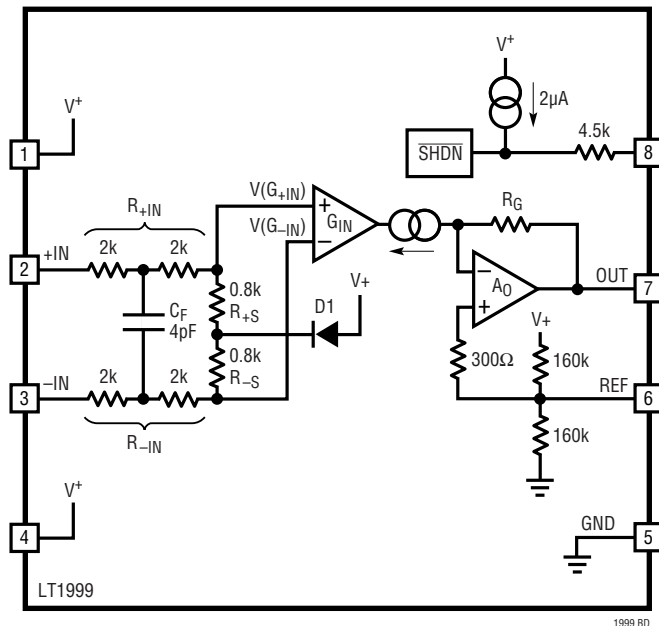

## QUICK START PROCEDURE

Demonstration circuit 1698 is easy to set up and evaluate the performance of the LT1999. Refer to Figure 1 for proper measurement equipment setup and follow the procedure:

1. With power off, connect a power supply to  $V^+$  and the common to GND. This supply should be between 4.5V and 5.5V. Connect a second supply's positive terminal to the  $V_{SENSE}^+$  and connect its common to the circuit ground. The second supply's (load supply) output voltage can range from -5V to 80V.
2. With power off, connect the load to the  $V_{SENSE}^-$ . If the load power source does not have accurate current readout a DMM may be connected in series with the load as shown in Figure 1.
3. Connect a voltmeter to the  $V_{OUT}$  terminal, with the common connected to the  $V_{REF}$  terminal. An oscilloscope can also be used to monitor  $V_{out}$  with respect to ground.
4. Turn on the power supply to the device and the load supply.
5. Measure the output voltage with respect to  $V_{REF}$ . The output voltage will be proportional to the load and with the factory set sense resistor will equal 0.5V per 1A.

**QUICK START PROCEDURE**

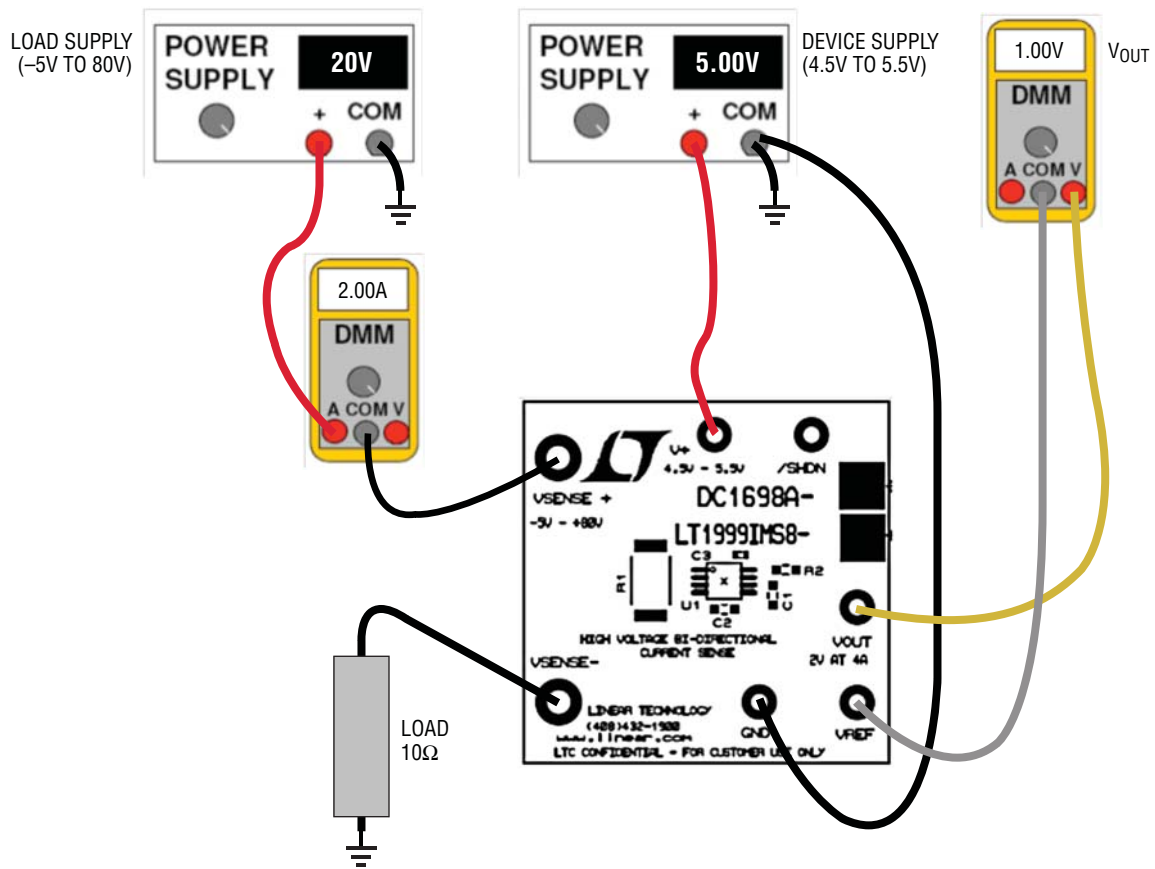

Figure 1. Proper Measurement Equipment Setup

# DEMO MANUAL DC1698A

## PARTS LIST

ITEM	QUANTITY	REFERENCE	DESCRIPTION	MANUFACTURER'S PART NUMBER
<b>General BOM</b>				
1	2	C1, C2	Capacitor, 0.1 $\mu$ F 10% 25V X7R 0603	AVX, 06033C104KAT2A
2	1	C3	Capacitor, 100pF 10% 16V X7R 0402	AVX, 0402YC101KAT2A
3	1	R2	Resistor, 0 $\Omega$ 0603 1% 1/16W	YAGEO, RC0603FR-070RL
<b>DC1698A-A</b>				
1	1	DC1698A	General BOM	
2	1	R1	Resistor, 0.05 $\Omega$ 1% 2512 2W	SEI, CSRN2512FT50L0
3	1	U1	IC, LT1999IMS8-10	Linear Technology, LT1999IMS8-10#PBF
<b>DC1698A-B</b>				
1	1	DC1698A	General BOM	
2	1	R1	Resistor, 0.025 $\Omega$ 1% 2512 1W	Vishay, WSL2512R0250FEA
3	1	U1	IC, LT1999IMS8-20	Linear Technology, LT1999IMS8-20#PBF
<b>DC1698A-C</b>				
1	1	DC1698A	General BOM	
2	1	R1	Resistor, 0.01 $\Omega$ 1W 1% 2512 SMD	Vishay, WSL2512R0100FEA
3	1	U1	IC, LT1999IMS8-50	Linear Technology, LT1999IMS8-50#PBF

**SCHEMATIC DIAGRAM**

REVISION HISTORY				
ECO	REV	DESCRIPTION	APPR	DATE
	1	PRODUCTION	CUYLER L.	10/01/2010

ASSY	U1	R1
-A	LT1999IMS8-10	0.05 ohm
-B	LT1999IMS8-20	0.025 ohm
-C	LT1999IMS8-50	0.01 ohm

<b>CUSTOMER NOTICE</b>		<b>APPROVALS</b>	
LINEAR TECHNOLOGY HAS MADE A BEST EFFORT TO DESIGN A CIRCUIT THAT MEETS CUSTOMER-SUPPLIED SPECIFICATIONS; HOWEVER, IT REMAINS THE CUSTOMER'S RESPONSIBILITY TO VERIFY PROPER AND RELIABLE OPERATION IN THE ACTUAL APPLICATION. COMPONENT SUBSTITUTION AND PRINTED CIRCUIT LAYOUT MAY SIGNIFICANTLY AFFECT CIRCUIT PERFORMANCE OR RELIABILITY. CONTACT LINEAR TECHNOLOGY APPLICATIONS ENGINEERING FOR ASSISTANCE.		PCB DES.	CL
THIS CIRCUIT IS PROPRIETARY TO LINEAR TECHNOLOGY AND SUPPLIED FOR USE WITH LINEAR TECHNOLOGY PARTS.		APP. ENG.	CUYLER L.
SCALE = NONE		TITLE: SCHEMATIC	

HIGH VOLTAGE BI-DIRECTIONAL CURRENT SENSE	
SIZE	REV
IC NO.	1
N/A	DEMO CIRCUIT 1698A
DATE:	SH 1 of 1
10/2010	

**NOTES: UNLESS OTHERWISE SPECIFIED**

- ALL RESISTORS ARE IN OHMS, 0603
- ALL CAPACTORS ARE IN MICROFARADS, 0603

# DEMO MANUAL DC1698A

---

## DEMONSTRATION BOARD IMPORTANT NOTICE

Linear Technology Corporation (LTC) provides the enclosed product(s) under the following **AS IS** conditions:

This demonstration board (DEMO BOARD) kit being sold or provided by Linear Technology is intended for use for **ENGINEERING DEVELOPMENT OR EVALUATION PURPOSES ONLY** and is not provided by LTC for commercial use. As such, the DEMO BOARD herein may not be complete in terms of required design-, marketing-, and/or manufacturing-related protective considerations, including but not limited to product safety measures typically found in finished commercial goods. As a prototype, this product does not fall within the scope of the European Union directive on electromagnetic compatibility and therefore may or may not meet the technical requirements of the directive, or other regulations.

If this evaluation kit does not meet the specifications recited in the DEMO BOARD manual the kit may be returned within 30 days from the date of delivery for a full refund. **THE FOREGOING WARRANTY IS THE EXCLUSIVE WARRANTY MADE BY THE SELLER TO BUYER AND IS IN LIEU OF ALL OTHER WARRANTIES, EXPRESSED, IMPLIED, OR STATUTORY, INCLUDING ANY WARRANTY OF MERCHANTABILITY OR FITNESS FOR ANY PARTICULAR PURPOSE. EXCEPT TO THE EXTENT OF THIS INDEMNITY, NEITHER PARTY SHALL BE LIABLE TO THE OTHER FOR ANY INDIRECT, SPECIAL, INCIDENTAL, OR CONSEQUENTIAL DAMAGES.**

The user assumes all responsibility and liability for proper and safe handling of the goods. Further, the user releases LTC from all claims arising from the handling or use of the goods. Due to the open construction of the product, it is the user's responsibility to take any and all appropriate precautions with regard to electrostatic discharge. Also be aware that the products herein may not be regulatory compliant or agency certified (FCC, UL, CE, etc.).

No License is granted under any patent right or other intellectual property whatsoever. **LTC assumes no liability for applications assistance, customer product design, software performance, or infringement of patents or any other intellectual property rights of any kind.**

LTC currently services a variety of customers for products around the world, and therefore this transaction **is not exclusive**.

**Please read the DEMO BOARD manual prior to handling the product.** Persons handling this product must have electronics training and observe good laboratory practice standards. **Common sense is encouraged.**

This notice contains important safety information about temperatures and voltages. For further safety concerns, please contact a LTC application engineer.

Mailing Address:

Linear Technology  
1630 McCarthy Blvd.  
Milpitas, CA 95035

Copyright © 2004, Linear Technology Corporation



Компания «ЭлектроПласт» предлагает заключение долгосрочных отношений при поставках импортных электронных компонентов на взаимовыгодных условиях!

Наши преимущества:

- Оперативные поставки широкого спектра электронных компонентов отечественного и импортного производства напрямую от производителей и с крупнейших мировых складов;
- Поставка более 17-ти миллионов наименований электронных компонентов;
- Поставка сложных, дефицитных, либо снятых с производства позиций;
- Оперативные сроки поставки под заказ (от 5 рабочих дней);
- Экспресс доставка в любую точку России;
- Техническая поддержка проекта, помощь в подборе аналогов, поставка прототипов;
- Система менеджмента качества сертифицирована по Международному стандарту ISO 9001;
- Лицензия ФСБ на осуществление работ с использованием сведений, составляющих государственную тайну;
- Поставка специализированных компонентов (Xilinx, Altera, Analog Devices, Intersil, Interpoint, Microsemi, Aeroflex, Peregrine, Syfer, Eurofarad, Texas Instrument, Miteq, Cobham, E2V, MA-COM, Hittite, Mini-Circuits, General Dynamics и др.);

Помимо этого, одним из направлений компании «ЭлектроПласт» является направление «Источники питания». Мы предлагаем Вам помощь Конструкторского отдела:

- Подбор оптимального решения, техническое обоснование при выборе компонента;
- Подбор аналогов;
- Консультации по применению компонента;
- Поставка образцов и прототипов;
- Техническая поддержка проекта;
- Защита от снятия компонента с производства.



#### Как с нами связаться

**Телефон:** 8 (812) 309 58 32 (многоканальный)

**Факс:** 8 (812) 320-02-42

**Электронная почта:** [org@eplast1.ru](mailto:org@eplast1.ru)

**Адрес:** 198099, г. Санкт-Петербург, ул. Калинина, дом 2, корпус 4, литера А.