

Product Specification

RoHS-6 Compliant 1G/10G 10km Datacom SFP+ Transceiver

FTLX1471D3BCV

PRODUCT FEATURES

- Hot-pluggable SFP+ footprint
- Supports rate selectable 1.25 Gb/s or 9.95 to 10.3 Gb/s bit rates
- Power dissipation < 1W
- RoHS-6 compliant (lead-free)
- Commercial temperature range -5°C to 70°C
- Single 3.3V power supply
- Maximum link length of 10km
- Uncooled 1310nm DFB laser
- Receiver limiting electrical interface
- Duplex LC connector
- Built-in digital diagnostic functions



APPLICATIONS

- 1000BASE-LX 1G Ethernet
- 10GBASE-LR/LW 10G Ethernet

Finisar's FTLX1471D3BCV 1G/10G Dual-Rate SFP+ transceivers are designed for use in 1-Gigabit and 10-Gigabit Ethernet links up to 10km over singlemode fiber. They are compliant with SFF-8431¹, IEEE 802.3-2005 10GBASE-LR/LW² and 1000BASE-LX³. Digital diagnostics functions are available via a 2-wire serial interface, as specified in SFF-8472⁴. This product is for applications specifically designed for 10G SFP+ ports and 1G/10G SFP+ ports and not native 1G SFP ports. The FTLX1471D3BCV is a "limiting module", i.e., it employs a limiting receiver. Host board designers using an EDC PHY IC should follow the IC manufacturer's recommended settings for interoperating the host-board EDC PHY with a limiting receiver SFP+ module. The transceiver is RoHS compliant and lead free per Directive 2002/95/EC⁵, and Finisar Application Note AN-2038⁶.

PRODUCT SELECTION

FTLX1471D3BCV

I. Pin Descriptions

Pin	Symbol	Name/Description	Ref.
1	VEET	Transmitter Ground	1
2	TFAULT	Transmitter Fault	2
3	TDIS	Transmitter Disable. Laser output disabled on high or open.	3
4	SDA	2-wire Serial Interface Data Line	4
5	SCL	2-wire Serial Interface Clock Line	4
6	MOD_ABS	Module Absent. Grounded within the module	4
7	RS0	RS0 for Rate Select: Open or Low = Module supports 1.25 Gb/s High = Module supports 9.95 Gb/s to 10.3125 Gb/s	5
8	RX_LOS	Loss of Signal indication. Logic 0 indicates normal operation.	6
9	RS1	No connection required	
10	V _{EER}	Receiver Ground	1
11	V _{EER}	Receiver Ground	1
12	RD-	Receiver Inverted DATA out. AC Coupled.	
13	RD+	Receiver Non-inverted DATA out. AC Coupled.	
14	V _{EER}	Receiver Ground	1
15	V _{CCR}	Receiver Power Supply	
16	V _{CCT}	Transmitter Power Supply	
17	V _{EET}	Transmitter Ground	1
18	TD+	Transmitter Non-Inverted DATA in. AC Coupled.	
19	TD-	Transmitter Inverted DATA in. AC Coupled.	
20	V _{EET}	Transmitter Ground	1

Notes:

1. Circuit ground is internally isolated from chassis ground.
2. T_{FAULT} is an open collector/drain output, which should be pulled up with a 4.7k – 10k Ohms resistor on the host board if intended for use. Pull up voltage should be between 2.0V to V_{cc} + 0.3V. A high output indicates a transmitter fault caused by either the TX bias current or the TX output power exceeding the preset alarm thresholds. A low output indicates normal operation. In the low state, the output is pulled to <0.8V.
3. Laser output disabled on T_{DIS} >2.0V or open, enabled on T_{DIS} <0.8V.
4. Internally pulled down per SFF-8431 Rev 3.0.
5. Transceiver data rate selected through the 2-wire bus in accordance with SFF-8472 Rev. 10.3. Soft RS0 is set at Bit3, Byte 110, Address A2h. Soft RS0 default state on power up is '0' LOW, and the state is reset following a power cycle. Writing '1' HIGH selects max. data rate operation. Transceiver data rate is the logic OR of the input state of the RS0 pin and soft RS0 bit. Thus, if either the RS0 pin OR the soft RS0 bit is HIGH then the selected data rate will be 9.95 and 10.3 Gb/s. Conversely, to select data rate 1.25 Gb/s both the RS0 pin and the soft RS0 bit are set LOW.
6. LOS is open collector output. Should be pulled up with 4.7k – 10kΩ on host board to a voltage between 2.0V and 3.6V. Logic 0 indicates normal operation; logic 1 indicates loss of signal.

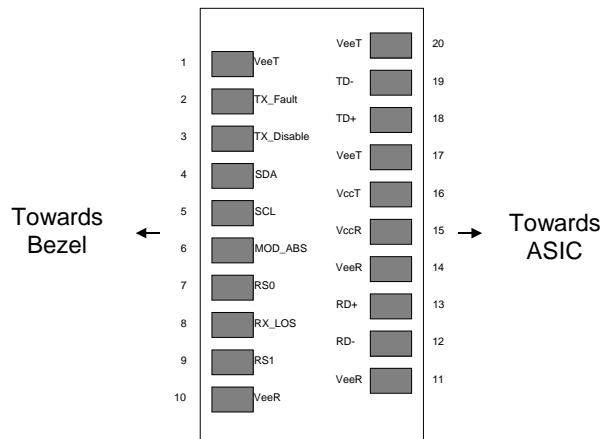

Figure 1. Diagram of Host Board Connector Block Pin Numbers and Names.

II. Absolute Maximum Ratings

Exceeding the limits below may damage the transceiver module permanently.

Parameter	Symbol	Min	Typ	Max	Unit	Ref.
Maximum Supply Voltage	V _{CC}	-0.5		4.0	V	
Storage Temperature	T _S	-40		85	°C	
Relative Humidity	RH	0		85	%	1

1. Non-condensing.

III. Electrical Characteristics (T_{OP} = -5 to 70 °C, V_{CC} = 3.14 to 3.46 Volts)

Parameter	Symbol	Min	Typ	Max	Unit	Ref.
Supply Voltage	V _{CC}	3.14		3.46	V	
Supply Current	I _{CC}		200	285	mA	
Transmitter						
Input differential impedance	R _{in}		100		Ω	1
Differential data input swing	V _{in,pp}	180		700	mV	2
Transmit Disable Voltage	V _D	2		V _{CC}	V	
Transmit Enable Voltage	V _{EN}	V _{EE}		V _{EE} +0.8	V	
Receiver						
Differential data output swing	V _{out,pp}	300		850	mV	3
Output rise time and fall time	T _r , T _f	30			ps	4
LOS Fault	V _{LOS fault}	2		V _{CCHOST}	V	5
LOS Normal	V _{LOS norm}	V _{EE}		V _{EE} +0.8	V	5
Power Supply Noise Tolerance	V _{CC} T/V _{CC} R	Per SFF-8431 Rev 3.0			mVpp	6

Notes:

1. Connected directly to TX data input pins. AC coupling from pins into laser driver IC.
2. Voltage swing for 1G operation is equivalent to voltage swing in 10G operation (SFF-8431 Rev 3.0).
3. Into 100Ω differential termination. Voltage swing for 1G operation is equivalent to voltage swing in 10G operation (SFF-8431 Rev 3.0).
4. 20 – 80%. Measured with Module Compliance Test Board and OMA test pattern. Use of four 1's and four 0's sequence in the PRBS 9 is an acceptable alternative.
5. LOS is an open collector output. Should be pulled up with 4.7kΩ – 10kΩ on the host board. Normal operation is logic 0; loss of signal is logic 1.
6. See Section 2.8.3 of SFF-8431 Rev 3.0.

IV. Optical Characteristics for RS0 = LOW (1G Operation)(T_{OP} = -5 to 70 °C, V_{CC3} = 3.14 to 3.46 Volts)

Parameter	Symbol	Min	Typ	Max	Unit	Ref.
Transmitter						
Average Launch Power	P _{AVE}	-11		-3	dBm	1
Optical Wavelength	λ	1260		1355	nm	
Rise-Fall Time	T _{rise} /T _{fall}			0.26	ns	2
RMS Spectral Width	$\Delta\lambda_{rms}$			4	nm	
Optical Extinction Ratio	ER	9			dB	
Average Launch power of OFF transmitter	P _{OFF}			-30	dBm	
Tx Jitter	T _{Xj}	Per 802.3-2005 requirements				
Relative Intensity Noise	RIN			-120	dB/Hz	
Receiver						
Receiver Sensitivity	R _{SENS}			-19	dBm	3
Stressed Receiver Sensitivity	SRS			-14.4	dBm	4
Average Receive Power	P _{AVE}			-3	dBm	
Optical Center Wavelength	λ_C	1260		1600	nm	
Return Loss	R _{rx}	12			dB	
Receive electrical 3dB upper cutoff frequency			1500		MHz	
LOS De-Assert	LOS _D			-17	dBm	
LOS Assert	LOS _A	-30			dBm	
LOS Hysteresis		0.5			dB	

Notes:

1. Average power figures are informative only, per IEEE 802.3-2005.
2. 20%-80%.
3. Valid between 1260 and 1355 nm. Measured with worst-case ER; BER < 10⁻¹²; 2³¹ – 1 PRBS.
4. Valid between 1260 and 1355 nm. Per IEEE 802.3-2005. 9dB extinction ratio transmitter.

V. Optical Characteristics for RS0 = HIGH (10G Operation)(T_{OP} = -5 to 70 °C, V_{CC3} = 3.14 to 3.46 Volts)

Parameter	Symbol	Min	Typ	Max	Unit	Ref.	
Transmitter							
Optical Modulation Amplitude (OMA)	P _{OMA}	-5.2			dBm		
Average Launch Power	P _{AVE}	-8.2		+0.5	dBm	1	
Optical Wavelength	λ	1260		1355	nm		
Side-Mode Suppression Ratio	SMSR	30			dB		
Optical Extinction Ratio	ER	3.5			dB		
Transmitter and Dispersion Penalty	TDP			3.2	dB		
Average Launch power of OFF transmitter	P _{OFF}			-30	dBm		
Tx Jitter	T _{Xj}	Per 802.3-2005 requirements					
Relative Intensity Noise	RIN			-128	dB/Hz		
Receiver							
Receiver Sensitivity (OMA) @ 10.3Gb/s	R _{SENS1}			-12.6	dBm	2	
Stressed Receiver Sensitivity (OMA) @ 10.3Gb/s	R _{SENS2}			-10.3	dBm	3	
Average Receive Power	P _{AVE}	-14.2		+0.5	dBm		
Optical Center Wavelength	λ _C	1260		1600	nm		
Receiver Reflectance	R _{FX}			-12	dB		
LOS De-Assert	LOS _D			-17	dBm		
LOS Assert	LOS _A	-30			dBm		
LOS Hysteresis		0.5			dB		

Notes:

1. Average power figures are informative only, per IEEE 802.3-2005.
2. Valid between 1260 and 1355 nm. Measured with worst ER; BER < 10⁻¹²; 2³¹ – 1 PRBS.
3. Valid between 1260 and 1355 nm. Per IEEE 802.3-2005.

VI. General Specifications

Parameter	Symbol	Min	Typ	Max	Units	Ref.
Bit Rate (RS0 = LOW)	BR		1.25		Gb/s	1
Bit Rate (RS0 = HIGH)	BR	9.95	10.3		Gb/s	2
Max. Supported Link Length	L _{MAX}		10		km	

Notes:

- 1000BASE-LX. Tested with a $2^7 - 1$ PRBS. See Section I, Note 5 for RS0 conditions for 1.25Gb/s operation.
- 10GBASE-LR/LW. Tested with a $2^{31} - 1$ PRBS. See Section I, Note 5 for RS0 conditions for 10.3 Gb/s operation.

VII. Environmental Specifications

Finisar FTLX1471D3BCV transceivers have an operating temperature range from -5°C to +70°C case temperature.

Parameter	Symbol	Min	Typ	Max	Units	Ref.
Case Operating Temperature	T _{op}	-5		70	°C	
Storage Temperature	T _{sto}	-40		85	°C	

VIII. Regulatory Compliance

Finisar transceivers are Class 1 Laser Products and comply with US FDA regulations. These products are certified by TÜV and CSA to meet the Class 1 eye safety requirements of EN (IEC) 60825 and the electrical safety requirements of EN (IEC) 60950. Copies of certificates are available at Finisar Corporation upon request.

IX. Digital Diagnostic Functions

Finisar FTLX1471D3BCV SFP+ transceivers support the 2-wire serial communication protocol as defined in the SFP MSA¹. It is very closely related to the E²PROM defined in the GBIC standard, with the same electrical specifications.

The standard SFP serial ID provides access to identification information that describes the transceiver's capabilities, standard interfaces, manufacturer, and other information.

Additionally, Finisar SFP+ transceivers provide an enhanced digital diagnostic monitoring interface, which allows real-time access to device operating parameters such as transceiver temperature, laser bias current, transmitted optical power, received optical power and transceiver supply voltage. It also defines a sophisticated system of alarm and warning flags, which alerts end-users when particular operating parameters are outside of a factory set normal range.

The SFP MSA defines a 256-byte memory map in E²PROM that is accessible over a 2-wire serial interface at the 8 bit address 1010000X (A0h). The digital diagnostic monitoring interface makes use of the 8 bit address 1010001X (A2h), so the originally defined serial ID memory map remains unchanged. The interface is identical to, and is thus fully backward compatible with both the GBIC Specification and the SFP Multi Source Agreement. The complete interface is described in Finisar Application Note AN-2030: "Digital Diagnostics Monitoring Interface for SFP Optical Transceivers".

The operating and diagnostics information is monitored and reported by a Digital Diagnostics Transceiver Controller (DDTC) inside the transceiver, which is accessed through a 2-wire serial interface. When the serial protocol is activated, the serial clock signal (SCL, Mod Def 1) is generated by the host. The positive edge clocks data into the SFP transceiver into those segments of the E²PROM that are not write-protected. The negative edge clocks data from the SFP transceiver. The serial data signal (SDA, Mod Def 2) is bi-directional for serial data transfer. The host uses SDA in conjunction with SCL to mark the start and end of serial protocol activation. The memories are organized as a series of 8-bit data words that can be addressed individually or sequentially.

For more information, please see the SFP MSA documentation^{1,5} and Finisar Application Note AN-2030.

X. Digital Diagnostic Specifications

FTLX1471D3BCV transceivers can be used in host systems that require either internally or externally calibrated digital diagnostics.

Parameter	Symbol	Min	Typ	Max	Units	Ref.
Accuracy						
Internally measured transceiver temperature	$\Delta DD_{\text{Temperature}}$			3	°C	
Internally measured transceiver supply voltage	$\Delta DD_{\text{Voltage}}$			3	%	
Measured TX bias current	ΔDD_{Bias}			10	%	1
Measured TX output power	$\Delta DD_{\text{Tx-Power}}$			2	dB	
Measured RX received average optical power	$\Delta DD_{\text{Rx-Power}}$			2	dB	
Dynamic Range for Rated Accuracy						
Internally measured transceiver temperature	$DD_{\text{Temperature}}$	-5		70	°C	
Internally measured transceiver supply voltage	DD_{Voltage}	3.1		3.5	V	
Measured TX bias current	DD_{Bias}	10		90	mA	
Measured TX output power	$DD_{\text{Tx-Power}}$	-8.2		+0.5	dBm	
Measured RX received average optical power	$DD_{\text{Rx-Power}}$	-14.2		+0.5	dBm	
Max Reporting Range						
Internally measured transceiver temperature	$DD_{\text{Temperature}}$	-40		125	°C	
Internally measured transceiver supply voltage	DD_{Voltage}	2.8		4.0	V	
Measured TX bias current	DD_{Bias}	0		20	mA	
Measured TX output power	$DD_{\text{Tx-Power}}$	-10		+2	dBm	
Measured RX received average optical power	$DD_{\text{Rx-Power}}$	-22		+2	dBm	

Notes:

- Accuracy of measured Tx bias current is 10% of the actual bias current from the laser driver to the laser.

XI. Mechanical Specifications

Finisar FTLX1471D3BCV SFP+ transceivers are compatible with the SFF-8432⁷ specification for improved pluggable form factor, and shown here for reference purposes only. Bail color is blue.

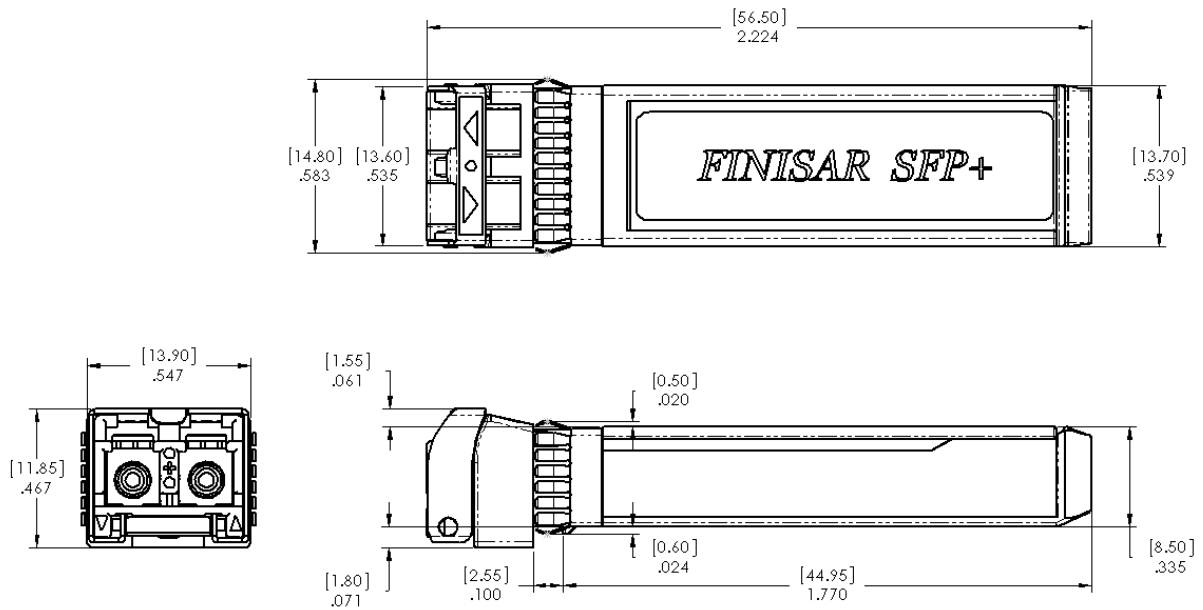

Figure 2. FTLX1471D3BCV Mechanical Dimensions.

XIII. Host - Transceiver Interface Block Diagram

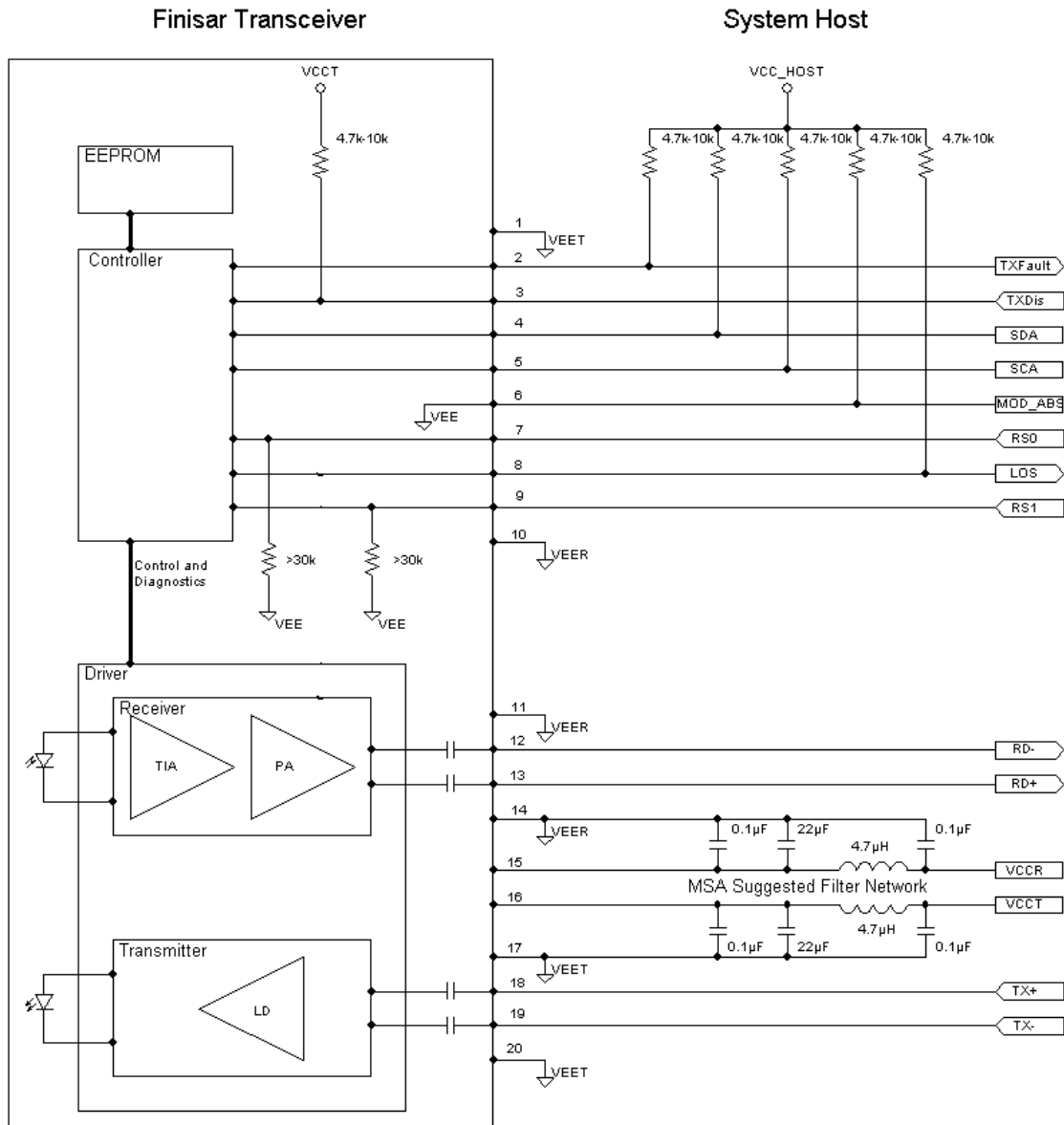

Figure 6-Host-Module Interface

XIV. References

1. “Specifications for Enhanced 8.5 and 10 Gigabit Small Form Factor Pluggable Module ‘SFP+ ’”, SFF Document Number SFF-8431, Revision 3.0.
2. IEEE Std 802.3-2005, PMD Type 10GBASE-LR/LW. IEEE Standards Department.
3. IEEE Std 802.3-2005, PMD Type 1000BASE-LX. IEEE Standards Department.
4. “Digital Diagnostics Monitoring Interface for Optical Transceivers”. SFF Document Number SFF-8472, Revision 10.1, March 1, 2007.
5. Directive 2002/95/EC of the European Council Parliament and of the Council, “on the restriction of the use of certain hazardous substances in electrical and electronic equipment”. January 27, 2003.
6. “Application Note AN-2038: Finisar Implementation Of RoHS Compliant Transceivers”, Finisar Corporation, January 21, 2005.
7. “Improved Pluggable Formfactor”, SFF Document Number SFF-8432, Revision 4.2, April 18, 2007.

XV. For More Information

Finisar Corporation
1389 Moffett Park Drive
Sunnyvale, CA 94089-1133
Tel. 1-408-548-1000
Fax 1-408-541-6138
sales@finisar.com
www.finisar.com



Компания «ЭлектроПласт» предлагает заключение долгосрочных отношений при поставках импортных электронных компонентов на взаимовыгодных условиях!

Наши преимущества:

- Оперативные поставки широкого спектра электронных компонентов отечественного и импортного производства напрямую от производителей и с крупнейших мировых складов;
- Поставка более 17-ти миллионов наименований электронных компонентов;
- Поставка сложных, дефицитных, либо снятых с производства позиций;
- Оперативные сроки поставки под заказ (от 5 рабочих дней);
- Экспресс доставка в любую точку России;
- Техническая поддержка проекта, помощь в подборе аналогов, поставка прототипов;
- Система менеджмента качества сертифицирована по Международному стандарту ISO 9001;
- Лицензия ФСБ на осуществление работ с использованием сведений, составляющих государственную тайну;
- Поставка специализированных компонентов (Xilinx, Altera, Analog Devices, Intersil, Interpoint, Microsemi, Aeroflex, Peregrine, Syfer, Eurofarad, Texas Instrument, Miteq, Cobham, E2V, MA-COM, Hittite, Mini-Circuits, General Dynamics и др.);

Помимо этого, одним из направлений компании «ЭлектроПласт» является направление «Источники питания». Мы предлагаем Вам помощь Конструкторского отдела:

- Подбор оптимального решения, техническое обоснование при выборе компонента;
- Подбор аналогов;
- Консультации по применению компонента;
- Поставка образцов и прототипов;
- Техническая поддержка проекта;
- Защита от снятия компонента с производства.



Как с нами связаться

Телефон: 8 (812) 309 58 32 (многоканальный)

Факс: 8 (812) 320-02-42

Электронная почта: org@eplast1.ru

Адрес: 198099, г. Санкт-Петербург, ул. Калинина, дом 2, корпус 4, литера А.