

Subminiature, LAN Modular Jack Connectors

TM11R-5M2 Series

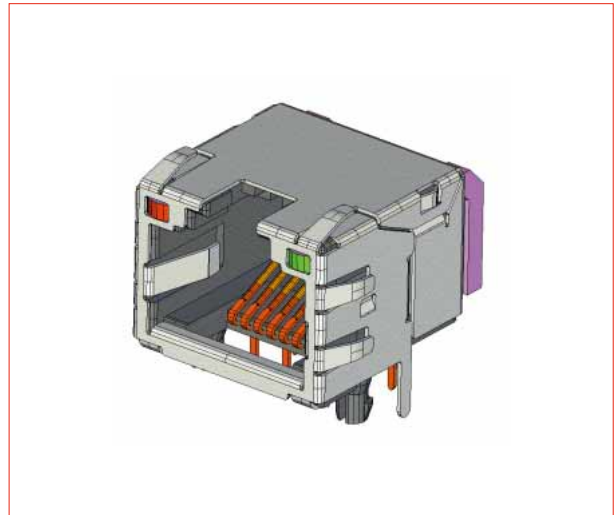
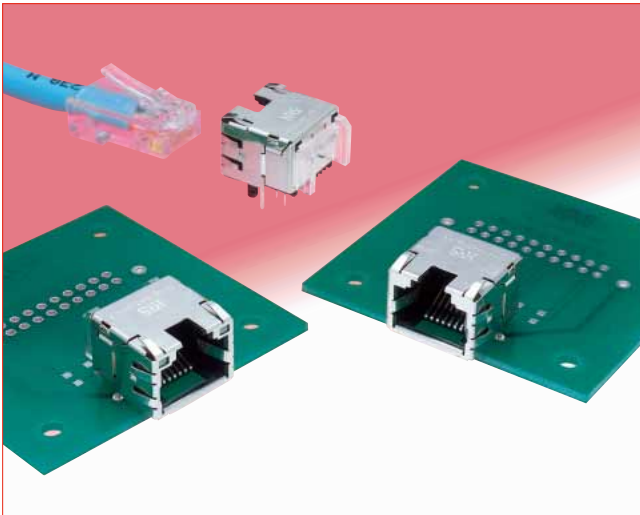

■ Features

1. Fast Ethernet Support

Conforms to the TIA/EIA-568-A data wiring standard and meets requirements of CAT5 transmission performance for 1,2-3,6 conductor pairs. As such, these products fully support Fast Ethernet (100BASE-TX) transmission.

2. Subminiature Design Contributes to Saving Space in the Equipment

Having built-in optical indicators, with height of only 11.5mm, width of 15mm and depth of 17.5mm the connectors can be used in extremely limited spaces.

3. Built-in Optical Indicators

Optical indicators are integral part of the connectors help saving space on customer's board.

Compared with LED type indicators, they do not emit any electrical noise.

4. EMI protection

Metal shield covers the outer surfaces of the connectors assuring complete protection against electromagnetic interference.

Built-in multiple shield and ground contacts assure reliable connection with the mounting panel as well as with the mating connectors.

5. Environmental considerations

Plating is lead-free in order to protect environment.

6. FCC Standards

Meets requirements of FCC Title 47, Part 68, Subpart F.

■ Applications

Telecom Hubs, Routers, Bridges and ATM Transmission Equipment, Ethernet Switches and Networking Equipment, Test and Measurement Equipment, Medical Diagnostic Equipment.

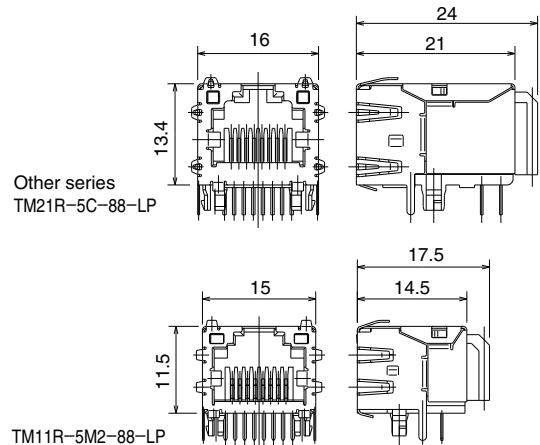

Space saving

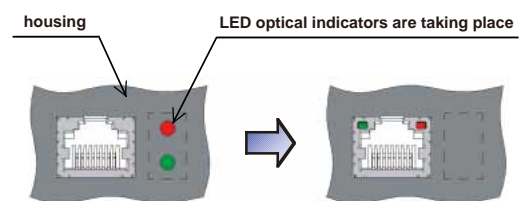

EMI protection

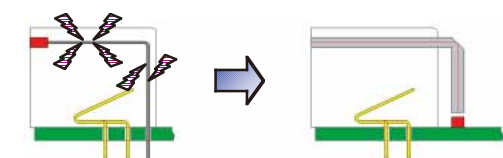

Built-in LED type
(Possibility of electromagnetic noise emission and interference.)

Built-in Optical pipe type
(No electromagnetic noise emission.)

Product Specifications

Rating	Current rating 1A	Operating temperature range : -25°C to +80°C (Note)
	Voltage rating 125V AC	

Item	Specification	Conditions
1. Insulation resistance	100MΩ min.	100V DC
2. Dielectric Withstanding Voltage (between adjacent contacts)	No flashover or insulation breakdown	500V AC applied for 1minute
3. Withstanding voltage (between contact and shield)	No flashover or insulation breakdown	1500V AC / 1minute
4. Contact resistance	230mΩ max.	100mA
5. Vibration	No electrical discontinuity of 5μ sec. or more. Contact resistance : 250mΩ max.	Frequency : 10 to 55Hz, single amplitude of 0.75mm, 2 hours / 3 axis
6. Shock	No electrical discontinuity of 5μ sec. or more. Contact resistance : 250mΩ max.	Acceleration of 490 m/s ² , 11ms duration, sine half-wave waveform, 3 cycles in each of the 3 axis
7. Durability (mating/un-mating)	Contact resistance : 250mΩ max.	200 cycles
8. Temperature cycle	Contact resistance : 250mΩ max. Insulation resistance : 100MΩ min.	Temperature : -55°C→+15°C to +35°C→+85°C→+15°C to +35°C Duration : 30→2 to 3→30→2 to 3 (Minutes) 5 cycles
9. Humidity	Contact resistance : 250mΩ max. Insulation resistance : 1MΩ min. (High humidity) Insulation resistance : 10MΩ min. (Dry state)	500 hours at temperature of 40°C and humidity of 90% to 95%
10. Salt Spray	Contact resistance : 250mΩ max.	Exposed to density 5% salt water for 48 hours

Note : Includes temperature rise caused by current flow.

Materials / Finish

Part	Material	Finish	Remarks
Insulator	PBT	Color : Black	UL94V-0
Contact	Copper alloy	Contact area : Gold plating Termination area : Tin alloy plating	—
Optical pipe	Polycarbonate	Color : Transparent	UL94V-0
Shield	Copper alloy	Tin plating	—

Product Number Structure

Refer to the chart below when determining the product specifications from the product number.
Please select from the product numbers listed in this catalog when placing orders.

● Jacks

TM11 R - 5M2 - 8 8 - LP

①
②
③
④ ⑤
⑥

① Series name	TM11 Series
② Connector type	R : Jack
③ Jack type	5M2 : PCB Right-angle through hole type
④ Jack opening code	8 : 8 contacts
⑤ Number of inserted contacts	8 : 8 contact
⑥ Optical pipe	LP : With optical pipe inserted Blank : Without optical pipe

◆ Recommended PCB mounting patterns

● With Built-in Optical Pipe

● Without Optical Pipe

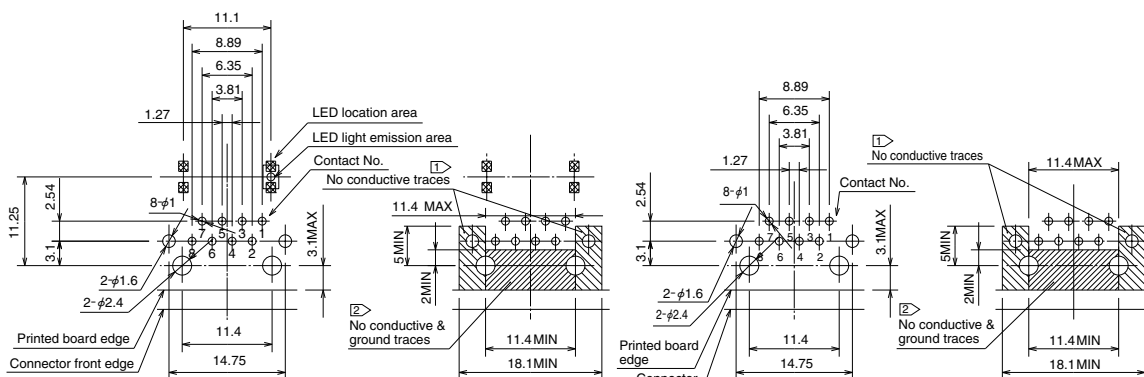

④ Suggested LEDs

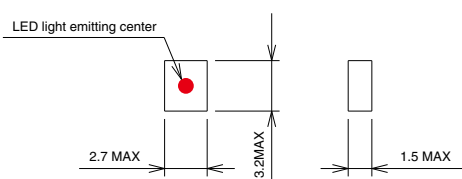

*Recommendations for PCB Design

- ① Areas indicated should be free of conductive traces.
- ② Area indicated should be free of conductive & ground traces.
- ③ Recommended board thickness : 1.6mm.
- ④ To assure that the indicator light pipes operates correctly the LED's must be installed directly on the PCB, within recommended dimensions and with light emitting center in upward direction.
Contact applicable manufacturer for LED specification.

◆ Panel Cutout

● For Both Types, With and Without Built-in Optical Pipe

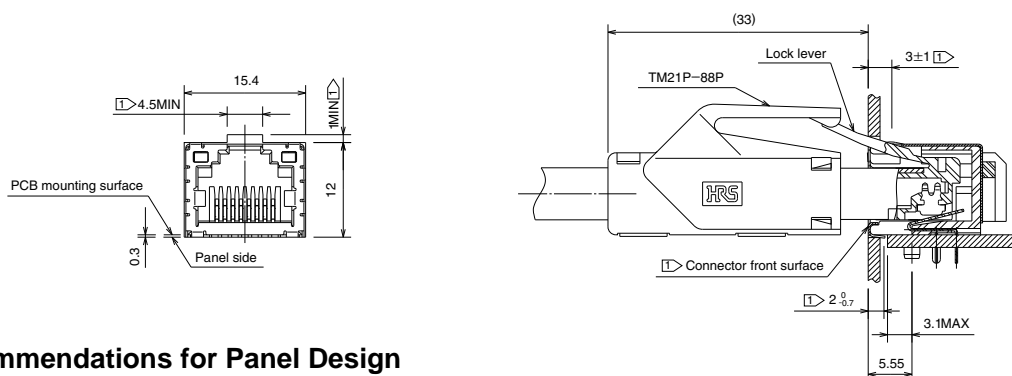

*Recommendations for Panel Design

- ① The shield contacts should connect with the panel cut-out on all sides.

Note : IPA cleaning at room temperature is recommended for the cleaning of this product.

When an aqueous cleaning agent is to be used, there is a concern that the light pipe (made of polycarbonate resin) may change color; therefore, please make a selection based on a table showing the effects on the resin. These tables are issued by the various manufacturers of cleaning agents.

◆ CAT5 Transmission Characteristics Data

For fully mated receptacle (TM11R-5M2-88-LP) and plug (TM21P-88P).

● Signal Attenuation

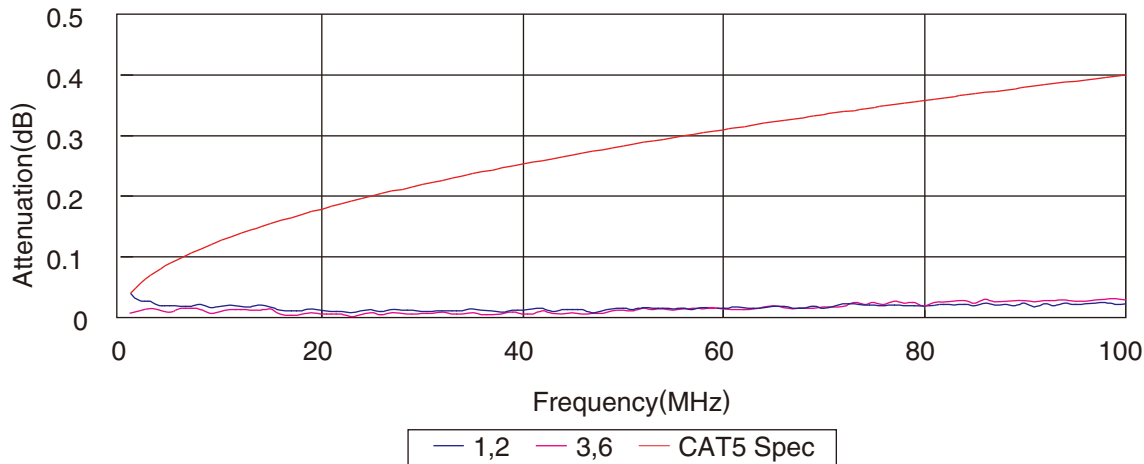

● Near-End Crosstalk (NEXT)

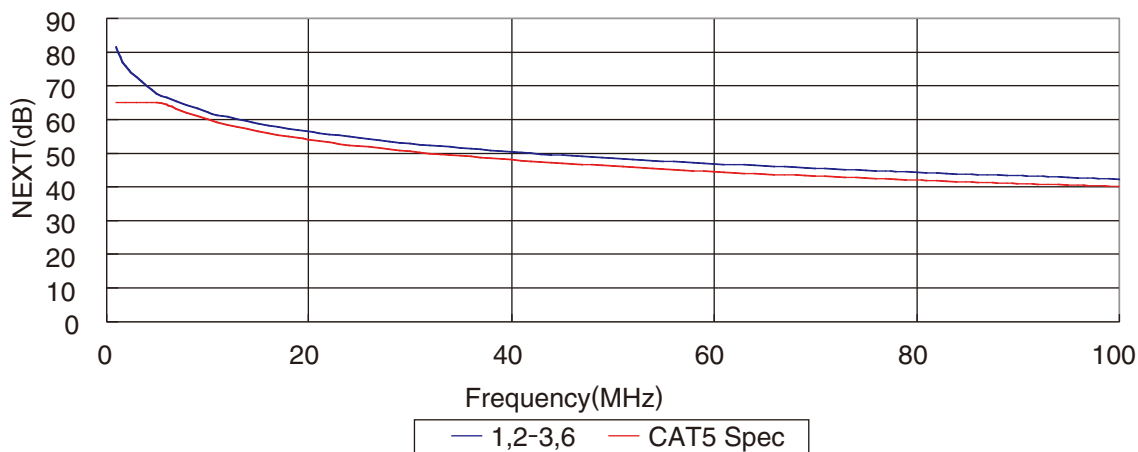

● Return Loss

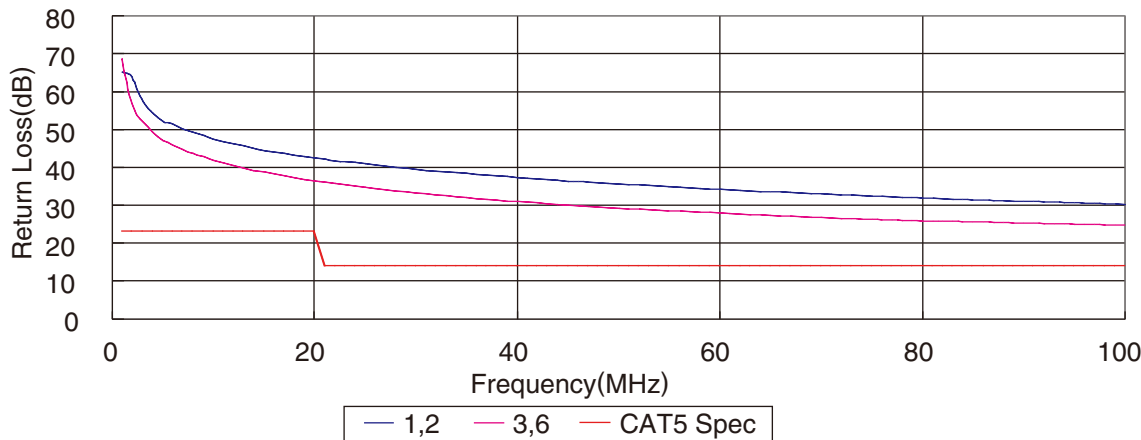

GUIDANCE FOR MODULAR CONNECTORS

■ Modular Connector Terminal Numbers

Unless otherwise specified, see the figures below for the terminal numbers of the product.

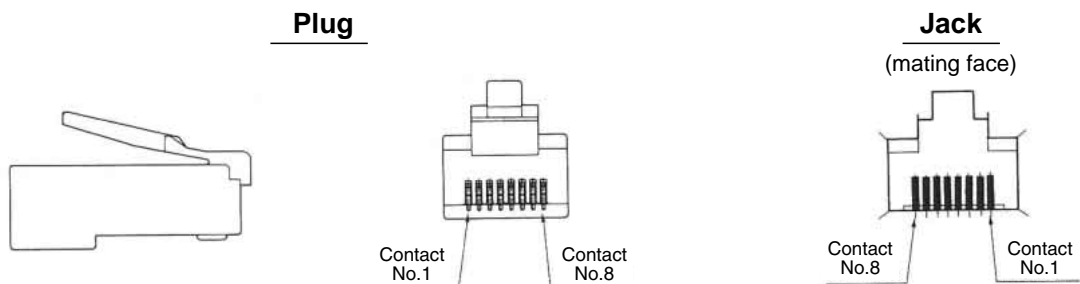

■ Attention to Plug Mating

Use only plugs conforming to FCC standards.
Please pay particular attention to dimensions shown right.

FCC PLUG DIMENSIONS

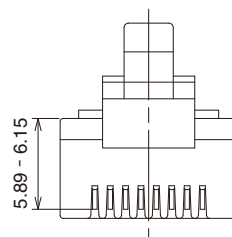

■ Opening Size and Number of Conductors(6-Conductor)

See the figures below for the relationship between the opening size and the number of conductors of the jack connectors.

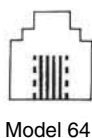
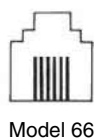

Models 64 and 62 are obtained by removing 1 pin and 2 pins, respectively, from both sides of model 66.
For details, please contact us for drawings because only standard models are shown in the catalogs.

■ Recommended Soldering for Modular Dip Connectors

- Flow solder (automatic soldering machine)
 - Pre-heat : 90 - 130°C
 - Pre-heat time : 120 seconds maximum
 - Solder temperature : 240 - 260°C
 - Soldering time : 10 seconds maximum
- Hand soldering
 - Soldering iron tip temperature : 350°C
 - Soldering temperature : 5 seconds maximum
 - Soldering iron output : 30 - 40W

Note : When soldering, use care not to apply excessive force to the connector terminals.

- Recommended Solder composition : Paste, 96.5%Sn/3.0%Ag/0.5%Cu



HIROSE ELECTRIC CO.,LTD.

2-6-3,Nakagawa Chuoh,Tsuzuki-Ku,Yokohama-Shi 224-8540,JAPAN
 TEL: +81-45-620-3526 Fax: +81-45-591-3726
<http://www.hirose.com>
<http://www.hirose-connectors.com>



Компания «ЭлектроПласт» предлагает заключение долгосрочных отношений при поставках импортных электронных компонентов на взаимовыгодных условиях!

Наши преимущества:

- Оперативные поставки широкого спектра электронных компонентов отечественного и импортного производства напрямую от производителей и с крупнейших мировых складов;
- Поставка более 17-ти миллионов наименований электронных компонентов;
- Поставка сложных, дефицитных, либо снятых с производства позиций;
- Оперативные сроки поставки под заказ (от 5 рабочих дней);
- Экспресс доставка в любую точку России;
- Техническая поддержка проекта, помощь в подборе аналогов, поставка прототипов;
- Система менеджмента качества сертифицирована по Международному стандарту ISO 9001;
- Лицензия ФСБ на осуществление работ с использованием сведений, составляющих государственную тайну;
- Поставка специализированных компонентов (Xilinx, Altera, Analog Devices, Intersil, Interpoint, Microsemi, Aeroflex, Peregrine, Syfer, Eurofarad, Texas Instrument, Miteq, Cobham, E2V, MA-COM, Hittite, Mini-Circuits, General Dynamics и др.);

Помимо этого, одним из направлений компании «ЭлектроПласт» является направление «Источники питания». Мы предлагаем Вам помощь Конструкторского отдела:

- Подбор оптимального решения, техническое обоснование при выборе компонента;
- Подбор аналогов;
- Консультации по применению компонента;
- Поставка образцов и прототипов;
- Техническая поддержка проекта;
- Защита от снятия компонента с производства.



Как с нами связаться

Телефон: 8 (812) 309 58 32 (многоканальный)

Факс: 8 (812) 320-02-42

Электронная почта: org@eplast1.ru

Адрес: 198099, г. Санкт-Петербург, ул. Калинина, дом 2, корпус 4, литера А.