



# Common Mode Filters

For high-speed differential signal line, general signal line

## ACM-E Series

# ACM2012E Type

---

ACM2012E

[0805 inch]\*

\* Dimensions Code JIS[EIA]

---

## REMINDERS FOR USING THESE PRODUCTS

Before using these products, be sure to request the delivery specifications.

### SAFETY REMINDERS

Please pay sufficient attention to the warnings for safe designing when using these products.

#### REMINDERS

- The storage period is less than 6 months. Be sure to follow the storage conditions (Temperature: 5 to 40°C, Humidity: 10 to 75% RH or less).  
If the storage period elapses, the soldering of the terminal electrodes may deteriorate.
- Do not use or store in locations where there are conditions such as gas corrosion (salt, acid, alkali, etc.).
- Before soldering, be sure to preheat components.  
The preheating temperature should be set so that the temperature difference between the solder temperature and chip temperature does not exceed 150°C.
- Soldering corrections after mounting should be within the range of the conditions determined in the specifications.  
If overheated, a short circuit, performance deterioration, or lifespan shortening may occur.
- When embedding a printed circuit board where a chip is mounted to a set, be sure that residual stress is not given to the chip due to the overall distortion of the printed circuit board and partial distortion such as at screw tightening portions.
- Self heating (temperature increase) occurs when the power is turned ON, so the tolerance should be sufficient for the set thermal design.
- Carefully lay out the coil for the circuit board design of the non-magnetic shield type.  
A malfunction may occur due to magnetic interference.
- Use a wrist band to discharge static electricity in your body through the grounding wire.
- Do not expose the products to magnets or magnetic fields.
- Do not use for a purpose outside of the contents regulated in the delivery specifications.
- The products listed on this catalog are intended for use in general electronic equipment (AV equipment, telecommunications equipment, home appliances, amusement equipment, computer equipment, personal equipment, office equipment, measurement equipment, industrial robots) under a normal operation and use condition.  
The products are not designed or warranted to meet the requirements of the applications listed below, whose performance and/or quality require a more stringent level of safety or reliability, or whose failure, malfunction or trouble could cause serious damage to society, person or property.  
If you intend to use the products in the applications listed below or if you have special requirements exceeding the range or conditions set forth in the each catalog, please contact us.

- (1) Aerospace/Aviation equipment
- (2) Transportation equipment (cars, electric trains, ships, etc.)
- (3) Medical equipment
- (4) Power-generation control equipment
- (5) Atomic energy-related equipment
- (6) Seabed equipment
- (7) Transportation control equipment

- (8) Public information-processing equipment
- (9) Military equipment
- (10) Electric heating apparatus, burning equipment
- (11) Disaster prevention/crime prevention equipment
- (12) Safety equipment
- (13) Other applications that are not considered general-purpose applications

When designing your equipment even for general-purpose applications, you are kindly requested to take into consideration securing protection circuit/device or providing backup circuits in your equipment.

# Common Mode Filters

Product compatible with RoHS directive  
Compatible with lead-free solders

For high-speed differential signal line, general signal line

## Overview of ACM2012E Type

### FEATURES

- Downsized, low height wound type chip common mode filter that maintains required common mode filter characteristics. Impedance for common mode noise can clear 1000Ω [100MHz], and has excellent EMC suppression.
- Differential mode impedance is suppressed, so there is virtually no affect on high speed signals.

### APPLICATION

- Common mode noise countermeasure for high-speed differential signals where influence to the signal is a concern.
- USB line for PCs and peripheral devices.
- IEEE1394 lines and ETHERNET lines for PCs, STBs, etc.
- LCD panel LVDS and Panel Link lines.

### PART NUMBER CONSTRUCTION

|                    |                              |             |                              |   |                                |      |                        |         |                        |             |                      |                                     |
|--------------------|------------------------------|-------------|------------------------------|---|--------------------------------|------|------------------------|---------|------------------------|-------------|----------------------|-------------------------------------|
| ACM                | 2012                         | -           | E                            | - | 670                            | -    | 2P                     | -       | T                      | -           | 00                   |                                     |
| <b>Series name</b> | <b>LxWxH Dimensions (mm)</b> |             | <b>Product internal code</b> |   | <b>Impedance (Ω) at 100MHz</b> |      | <b>Number of lines</b> |         | <b>Packaging style</b> |             | <b>Internal code</b> |                                     |
|                    | 2012                         | 2.0x1.2x1.0 | E                            |   | 670                            | 67   | 2P                     | 2 lines | T                      | ø180mm reel | 00                   | General signal line                 |
|                    |                              |             |                              |   | 900                            | 90   |                        |         | TL                     | ø330mm reel | 01                   | High-speed differential signal line |
|                    |                              |             |                              |   | 121                            | 120  |                        |         |                        |             |                      |                                     |
|                    |                              |             |                              |   | 181                            | 180  |                        |         |                        |             |                      |                                     |
|                    |                              |             |                              |   | 251                            | 250  |                        |         |                        |             |                      |                                     |
|                    |                              |             |                              |   | 391                            | 390  |                        |         |                        |             |                      |                                     |
|                    |                              |             |                              |   | 681                            | 680  |                        |         |                        |             |                      |                                     |
|                    |                              |             |                              |   | 102                            | 1000 |                        |         |                        |             |                      |                                     |

### OPERATING TEMPERATURE RANGE, PACKAGE QUANTITY, PRODUCT WEIGHT

| Type     | Temperature range             |                              | Reel diameter<br>(mm) | Package quantity<br>(pieces/reel) | Individual weight<br>(mg) |
|----------|-------------------------------|------------------------------|-----------------------|-----------------------------------|---------------------------|
|          | Operating temperature<br>(°C) | Storage temperature*<br>(°C) |                       |                                   |                           |
| ACM2012E | -40 to +85                    | -40 to +85                   | ø180                  | 2,000                             | 8                         |
|          |                               |                              | ø330                  | 10,000                            |                           |

\* The Storage temperature range is for after the circuit board is mounted.

○ RoHS Directive Compliant Product: See the following for more details related to RoHS Directive compliant products. <http://product.tdk.com/en/environment/rohs/>

 Please be sure to request delivery specifications that provide further details on the features and specifications of the products for proper and safe use. Please note that the contents may change without any prior notice due to reasons such as upgrading.

# ACM2012E Type

## RECOMMENDED REFLOW PROFILE

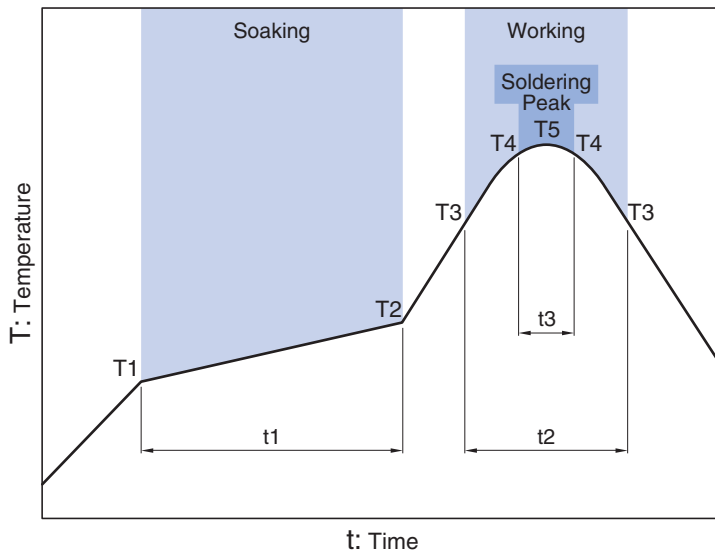

| Preheating |       |            | Soldering |           | Peak  |      |
|------------|-------|------------|-----------|-----------|-------|------|
| Temp.      | Temp. | Time       | Temp.     | Time      | Temp. | Time |
| T1         | T2    | t1         | T3        | t2        | T4    | t3   |
| 150°C      | 180°C | 60 to 120s | 230°C     | 10 to 30s | 245°C | 5s   |

# ACM2012E Type (General signal line)

## SHAPE & DIMENSIONS

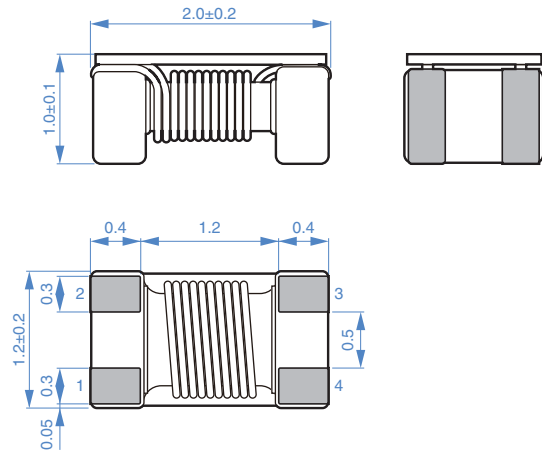

Dimensions in mm



## RECOMMENDED LAND PATTERN

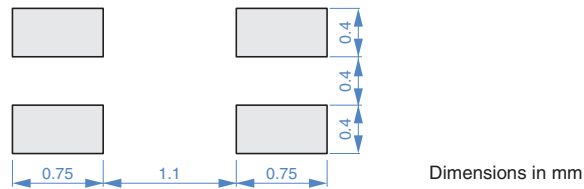

Dimensions in mm

## CIRCUIT DIAGRAM

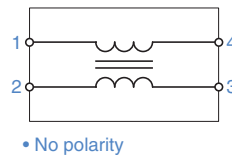

Please be sure to request delivery specifications that provide further details on the features and specifications of the products for proper and safe use. Please note that the contents may change without any prior notice due to reasons such as upgrading.

# ACM2012E Type (General signal line)

## ELECTRICAL CHARACTERISTICS

### CHARACTERISTICS SPECIFICATION TABLE

| Impedance<br>[100MHz]<br>( $\Omega$ ) | DC resistance<br>[1 line]<br>( $\Omega$ )max. | Rated voltage<br>(V)max. | Rated current<br>(A)max. | Part No.            |
|---------------------------------------|-----------------------------------------------|--------------------------|--------------------------|---------------------|
| 67 $\pm$ 25%                          | 0.35                                          | 50                       | 0.50                     | ACM2012E-670-2P-T00 |
| 90 $\pm$ 25%                          | 0.35                                          | 50                       | 0.33                     | ACM2012E-900-2P-T00 |
| 120 $\pm$ 25%                         | 0.45                                          | 50                       | 0.30                     | ACM2012E-121-2P-T00 |
| 180 $\pm$ 25%                         | 0.60                                          | 50                       | 0.25                     | ACM2012E-181-2P-T00 |
| 250 $\pm$ 25%                         | 1.00                                          | 50                       | 0.20                     | ACM2012E-251-2P-T00 |
| 270min. (390typ.)                     | 0.80                                          | 50                       | 0.30                     | ACM2012E-391-2P-T00 |
| 510min. (680typ.)                     | 1.80                                          | 50                       | 0.17                     | ACM2012E-681-2P-T00 |
| 750min. (1000typ.)                    | 2.50                                          | 50                       | 0.15                     | ACM2012E-102-2P-T00 |

#### Measurement equipment

| Measurement item      | Product No. | Manufacturer         |
|-----------------------|-------------|----------------------|
| Common mode impedance | 4991A       | Agilent Technologies |
| DC resistance         | 4338A       | Agilent Technologies |
| Insulation resistance | 4339A       | Agilent Technologies |

\* Equivalent measurement equipment may be used.

### IMPEDANCE VS. FREQUENCY CHARACTERISTICS



#### Measurement equipment

| Product No. | Manufacturer         |
|-------------|----------------------|
| 4991A       | Agilent Technologies |

\* Equivalent measurement equipment may be used.

Please be sure to request delivery specifications that provide further details on the features and specifications of the products for proper and safe use. Please note that the contents may change without any prior notice due to reasons such as upgrading.

# ACM2012E Type (high-speed differential signal line)

## SHAPE & DIMENSIONS

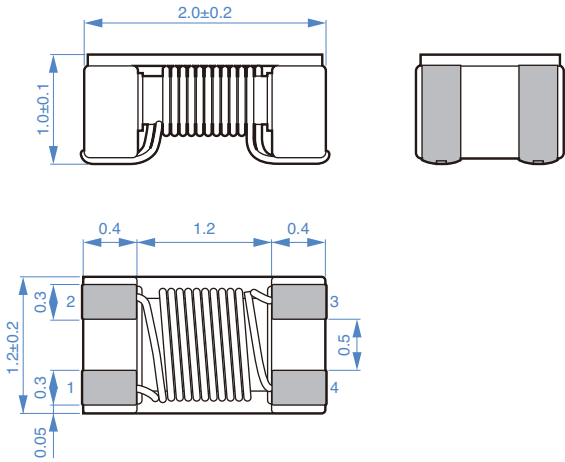

Dimensions in mm



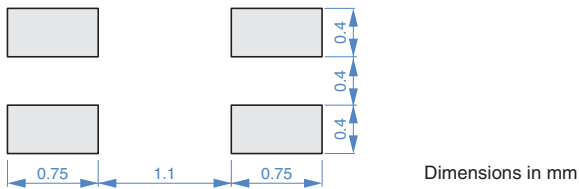

## RECOMMENDED LAND PATTERN

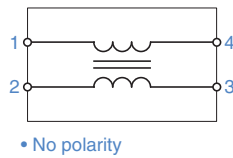

Dimensions in mm

## CIRCUIT DIAGRAM



 Please be sure to request delivery specifications that provide further details on the features and specifications of the products for proper and safe use. Please note that the contents may change without any prior notice due to reasons such as upgrading.

# ACM2012E Type (high-speed differential signal line)

## ELECTRICAL CHARACTERISTICS

### CHARACTERISTICS SPECIFICATION TABLE

| Impedance<br>[100MHz]<br>( $\Omega$ ) | DC resistance<br>[1 line]<br>( $\Omega$ )max. | Rated voltage<br>(V)max. | Rated current<br>(A)max. | Part No.            |
|---------------------------------------|-----------------------------------------------|--------------------------|--------------------------|---------------------|
| 67 $\pm$ 25%                          | 0.45                                          | 50                       | 0.35                     | ACM2012E-670-2P-T01 |
| 90 $\pm$ 25%                          | 0.55                                          | 50                       | 0.30                     | ACM2012E-900-2P-T01 |
| 120 $\pm$ 25%                         | 0.65                                          | 50                       | 0.27                     | ACM2012E-121-2P-T01 |
| 180 $\pm$ 25%                         | 1.00                                          | 50                       | 0.25                     | ACM2012E-181-2P-T01 |

#### Measurement equipment

| Measurement item      | Product No. | Manufacturer         |
|-----------------------|-------------|----------------------|
| Common mode impedance | 4991A       | Agilent Technologies |
| DC resistance         | 4338A       | Agilent Technologies |
| Insulation resistance | 4339A       | Agilent Technologies |

\* Equivalent measurement equipment may be used.

### IMPEDANCE VS. FREQUENCY CHARACTERISTICS

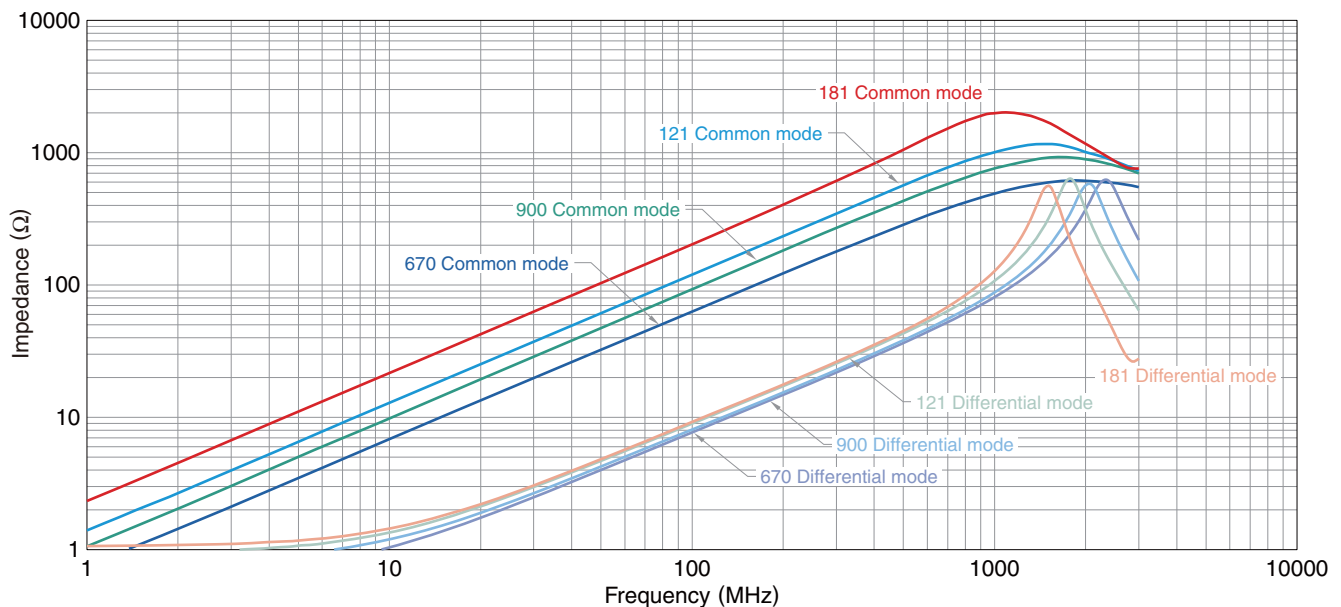

#### Measurement equipment

| Product No. | Manufacturer         |
|-------------|----------------------|
| 4991A       | Agilent Technologies |

\* Equivalent measurement equipment may be used.

 Please be sure to request delivery specifications that provide further details on the features and specifications of the products for proper and safe use. Please note that the contents may change without any prior notice due to reasons such as upgrading.



# ACM2012E Type

## PACKAGING STYLE

### REEL DIMENSIONS



| Type     | A                | W1            | W2           | N              | E      |
|----------|------------------|---------------|--------------|----------------|--------|
| ACM2012E | $\phi 330 \pm 2$ | $9.5 \pm 0.5$ | $13.5 \pm 1$ | $100 \pm 1$    | 2 typ. |
|          | $\phi 180 \pm 3$ | $9 + 1 / - 0$ | $13 \pm 1$   | $60 + 1 / - 0$ | 2 typ. |

Dimensions in mm

### TAPE DIMENSIONS



Dimensions in mm

| Type     | A             | B              | $\phi D0$       | E              | F             | P0            | P1            | P2            | W             | K               | t               |
|----------|---------------|----------------|-----------------|----------------|---------------|---------------|---------------|---------------|---------------|-----------------|-----------------|
| ACM2012E | $1.4 \pm 0.1$ | $2.25 \pm 0.1$ | $1.5 + 0.1 / 0$ | $1.75 \pm 0.1$ | $3.5 \pm 0.1$ | $4.0 \pm 0.1$ | $4.0 \pm 0.1$ | $2.0 \pm 0.1$ | $8.0 \pm 0.2$ | $1.15 \pm 0.05$ | $0.20 \pm 0.05$ |



Dimensions in mm

Please be sure to request delivery specifications that provide further details on the features and specifications of the products for proper and safe use. Please note that the contents may change without any prior notice due to reasons such as upgrading.



Компания «ЭлектроПласт» предлагает заключение долгосрочных отношений при поставках импортных электронных компонентов на взаимовыгодных условиях!

Наши преимущества:

- Оперативные поставки широкого спектра электронных компонентов отечественного и импортного производства напрямую от производителей и с крупнейших мировых складов;
- Поставка более 17-ти миллионов наименований электронных компонентов;
- Поставка сложных, дефицитных, либо снятых с производства позиций;
- Оперативные сроки поставки под заказ (от 5 рабочих дней);
- Экспресс доставка в любую точку России;
- Техническая поддержка проекта, помощь в подборе аналогов, поставка прототипов;
- Система менеджмента качества сертифицирована по Международному стандарту ISO 9001;
- Лицензия ФСБ на осуществление работ с использованием сведений, составляющих государственную тайну;
- Поставка специализированных компонентов (Xilinx, Altera, Analog Devices, Intersil, Interpoint, Microsemi, Aeroflex, Peregrine, Syfer, Eurofarad, Texas Instrument, Miteq, Cobham, E2V, MA-COM, Hittite, Mini-Circuits, General Dynamics и др.);

Помимо этого, одним из направлений компании «ЭлектроПласт» является направление «Источники питания». Мы предлагаем Вам помощь Конструкторского отдела:

- Подбор оптимального решения, техническое обоснование при выборе компонента;
- Подбор аналогов;
- Консультации по применению компонента;
- Поставка образцов и прототипов;
- Техническая поддержка проекта;
- Защита от снятия компонента с производства.



#### Как с нами связаться

**Телефон:** 8 (812) 309 58 32 (многоканальный)

**Факс:** 8 (812) 320-02-42

**Электронная почта:** [org@eplast1.ru](mailto:org@eplast1.ru)

**Адрес:** 198099, г. Санкт-Петербург, ул. Калинина, дом 2, корпус 4, литера А.