

APPLICATIONS

- DIESEL ENGINES
- REFRIGERATION AND HVAC SYSTEMS
- HYDRAULIC FLUID PRESSURES
- GENERAL INDUSTRIAL PRESSURE
- OFF ROAD VEHICLES

MODEL ML • OEM PRESSURE TRANSDUCER

The model ML pressure transducer combines the latest in ASIC technology with our proven stainless steel design. This digitally compensated transducer offers an unparalleled value and performance combination making it the ideal pressure sensing solution for demanding automotive and industrial applications. Fully temperature compensated, calibrated, and amplified, the ML is available in 100 to 5000 PSIS pressure ranges.

The ML has three standard output options: a 0.50 to 4.50 Vdc ratiometric output from 5 Vdc excitation, a 1.0 to 6.0 Vdc regulated output from 7-35 Vdc excitation, and a 4-20 mA current from 9-35 Vdc excitation. The ML transducer delivers $\pm 0.25\%$ full scale accuracy (BFSL) over a wide temperature range of -40°C to 105°C and utilizes a proven industry standard connector for high reliability and user flexibility.



FEATURES

- High value and outstanding performance
- No internal elastomeric seals
- Amplified outputs
- Reverse polarity protection
- Less than 500 microseconds response time
- Designed to meet IP65 standards*
- Exceeds CE Heavy Industrial EMC

BENEFITS

- Excellent OEM value
- Eliminates O-Ring compatability issues
- Eliminates cost of external amplifiers
- Not damaged by reversed excitation
- Accurate high speed measurements
- Protected from harsh environments

* With appropriate mating connector, Packard #12065287.

HOW TO ORDER

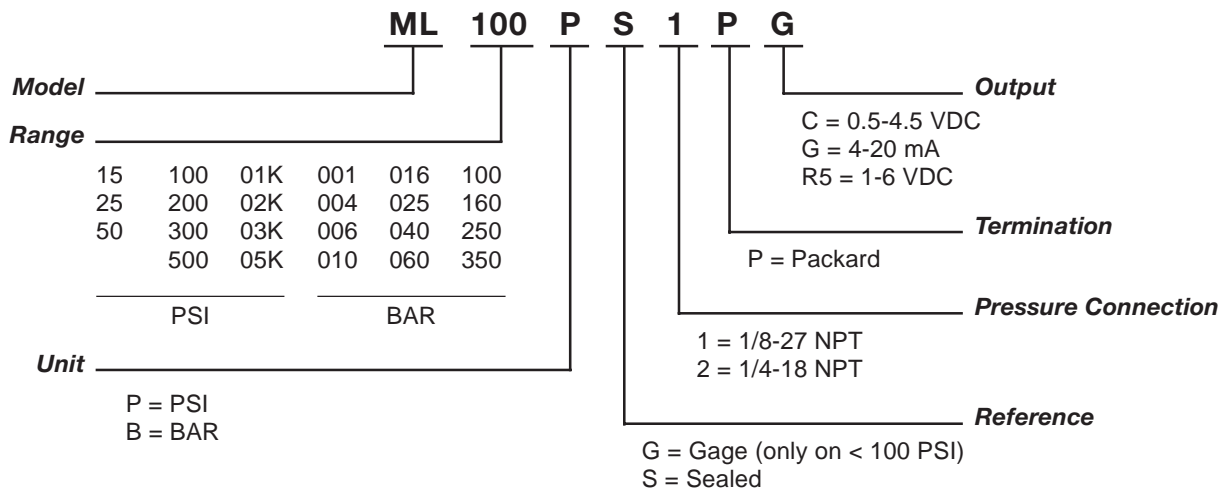

Note: Not all combinations are available. Minimum quantity orders apply. Contact the factory for more details.

TECHNICAL SPECIFICATIONS

RANGES

15, 25, 50 PSIG; 100, 200, 300, 500, 1000, 2000, 3000, 5000 PSIS
6, 10, 16, 25, 40, 60, 100, 160, 250 BAR

PHYSICAL

Proof Pressure	< 500 psi 2 X rated range	≥ 500 psi 1.5 X rated range
Burst Pressure	< 500 psi 10 X rated range	≥ 500 psi (30K psi max) 10 X rated range
Material in Contact with Media	300 series SS, braze compound	
Weight	2.0 oz (57 gm)	

ENVIRONMENTAL

Shock	50 g's peak (5 ms), 100 g's peak (11 ms)	
Vibration	Figure 514.2-5, Curve AK, Table 514.2-V Random Vibration Test (Overall g rms = 20.7 minimum)	

ELECTRICAL	Ratiometric Voltage	Regulated	Current
Zero Output	0.5 Vdc	1.0 Vdc	4.0 mA
Full Scale Output*	4.0 Vdc (0.50-4.50 Vdc)	5.0 Vdc (1.0-6.0 Vdc)	16 mA (4-20 mA)
Excitation	5 Vdc ±250 mV (7.0 V max)	7-35 Vdc	9.5-35 Vdc
Supply Current	5 mA typical (7 mA max)	5 mA typical (7 mA max)	N/A
Source (nominal)	2.0 mA	2.0 mA	N/A
Sink (nominal)	20 µA @ zero output	20 µA @ zero output	N/A
Supply Rejection Ratio	90 db	90 db	90 db
Output Impedance	25 W max.	25 W max.	N/A

PERFORMANCE

Response Time	< 500 microseconds
EMI/RFI	Exceeds CE heavy industrial (30v/m radiated 150kHz-1GHz)
Electrical Connection	Packard Metri-Pack™ connector requires Packard #12065287 mating connector
Accuracy	±0.25% F.S.O. best fit straight line. Includes: non-linearity, hysteresis, non-repeatability. Thermal errors not included. 0.5% < 100 PSI **
Total Error Band	±2% Typical (±3% Max.) F.S.O. Includes: zero offset error, span error, thermal effect on zero and thermal effect on span, non-linearity, hysteresis, non-repeatability
Compensated Operating and Storage Temperature Range	-40° to 105°C (-40° to 221°F)

* PSIG vented thru vent hole protected by Gortex® filter

NOTE: All specifications are measured at 25° C (77° F) and at rated excitation unless otherwise specified.

NOTE: Meets IEC-68-2 or MIL-STD 810C.

NOTE: Contact the factory to discuss other pressure ranges.

Item # 1121700 M.G. 3/01 Rev. A

DIMENSIONS

xx.xx = inches
(xx.x) = mm

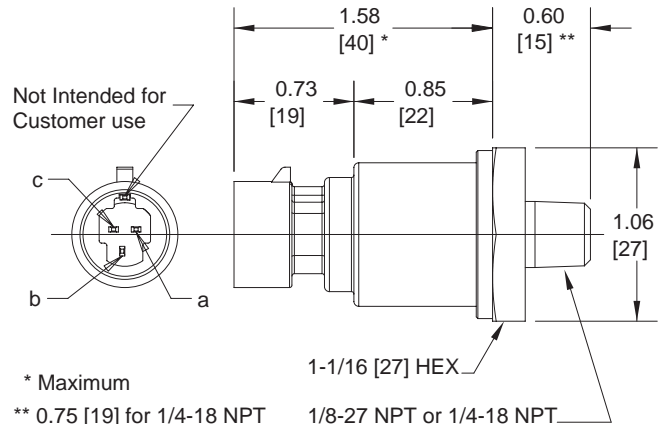

PIN AND WIRE CODES

Pins	Voltage	Current
A	+ Excitation	+ Excitation
B	Output	- Excitation
C	Common	NC

WARRANTY/REMEDY

Honeywell warrants goods of its manufacture as being free of defective materials and faulty workmanship. Contact your local sales office for warranty information. If warranted goods are returned to Honeywell during the period of coverage, Honeywell will repair or replace without charge those items it finds defective. The foregoing is Buyer's sole remedy and is in lieu of all other warranties, expressed or implied, including those of merchantability and fitness for a particular purpose.

Specifications may change without notice. The information we supply is believed to be accurate and reliable as of this printing. However, we assume no responsibility for its use.

While we provide application assistance personally, through our literature and the Honeywell web site, it is up to the customer to determine the suitability of the product in the application.

Honeywell

Sensing and Control
Honeywell
100 Discovery Way
Acton, MA 01720 USA

Tel: (877) 384-1300; Fax: (978) 263-0630

www.honeywell.com/sensing/



Компания «ЭлектроПласт» предлагает заключение долгосрочных отношений при поставках импортных электронных компонентов на взаимовыгодных условиях!

Наши преимущества:

- Оперативные поставки широкого спектра электронных компонентов отечественного и импортного производства напрямую от производителей и с крупнейших мировых складов;
- Поставка более 17-ти миллионов наименований электронных компонентов;
- Поставка сложных, дефицитных, либо снятых с производства позиций;
- Оперативные сроки поставки под заказ (от 5 рабочих дней);
- Экспресс доставка в любую точку России;
- Техническая поддержка проекта, помощь в подборе аналогов, поставка прототипов;
- Система менеджмента качества сертифицирована по Международному стандарту ISO 9001;
- Лицензия ФСБ на осуществление работ с использованием сведений, составляющих государственную тайну;
- Поставка специализированных компонентов (Xilinx, Altera, Analog Devices, Intersil, Interpoint, Microsemi, Aeroflex, Peregrine, Syfer, Eurofarad, Texas Instrument, Miteq, Cobham, E2V, MA-COM, Hittite, Mini-Circuits, General Dynamics и др.);

Помимо этого, одним из направлений компании «ЭлектроПласт» является направление «Источники питания». Мы предлагаем Вам помощь Конструкторского отдела:

- Подбор оптимального решения, техническое обоснование при выборе компонента;
- Подбор аналогов;
- Консультации по применению компонента;
- Поставка образцов и прототипов;
- Техническая поддержка проекта;
- Защита от снятия компонента с производства.



Как с нами связаться

Телефон: 8 (812) 309 58 32 (многоканальный)

Факс: 8 (812) 320-02-42

Электронная почта: org@eplast1.ru

Адрес: 198099, г. Санкт-Петербург, ул. Калинина, дом 2, корпус 4, литера А.