

DIO5151B

700mA/1A Buck/Boost Charge Pump LED Driver

Features

- Output Current :
DIO5151BED8: 700mA
DIO5151BCD10: 1A
- Up to 90% Efficiency in Torch Mode
- Adjustable FLASH Mode Current
- 1× and 2× Automatic Modes for High Efficiency
- Input Voltage Range: 3V to 5.5V
- Minimum External Components: No Inductors
- High Frequency Operation: 2MHz
- Low 47mV Reference for Low Loss Sensing
- $I_q < 1\mu A$ in Shutdown
- Built-In Soft Start Limits Inrush Current
- Low Input and Output Ripple and Low EMI
- Output Over Voltage Protection
- Output Open and Output Short Protection
- Over-current and Over-temperature Protection
- Package: DFN2*2.2-8, DFN3*3-10

Applications

- Cellular Telephones
- Digital Still Cameras
- Mobile Internet Device
- USB Bus-Powered Chargers

Block Diagram

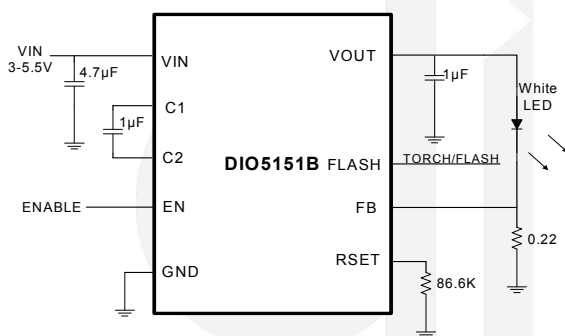

Descriptions

The DIO5151B is a current-regulated charge pump ideal for powering high brightness LEDs for camera flash applications. The charge pump can be set to regulate two current levels for FLASH and TORCH modes.

The DIO5151B automatically switches modes between step-up and step-down ensuring that LED current does not depend on the forward voltage. It switches at 2MHz, allowing the use of tiny components. The supply voltage ranges from 3V to 5.5V and is ideally suited for all applications powered by a single LI-Ion battery cell or three to four NiCd, NiMH, or Alkaline battery cells.

The DIO5151B also features a very low shutdown current, an automatic soft-start mode to limit inrush current, as well as over current, over voltage and over thermal shutdown control. A low current sense reference voltage (47mV) allows the use of small 0603 current sensing resistors.

The DIO5151B is available in Green DFN2*2.2-8, DFN3*3-10 package and is specified over an ambient temperature range of -40°C to +85°C.

Ordering Information

| Order Part Number | Top Marking | | T _A | Package | |
|-------------------|-------------|-------|----------------|------------|-------------------|
| DIO5151BED8 | 51B | Green | -40 to +85°C | DFN2*2.2-8 | Tape & Reel, 3000 |
| DIO5151BCD10 | D51B | Green | -40 to +85°C | DFN3*3-10 | Tape & Reel, 5000 |

Pin Assignment

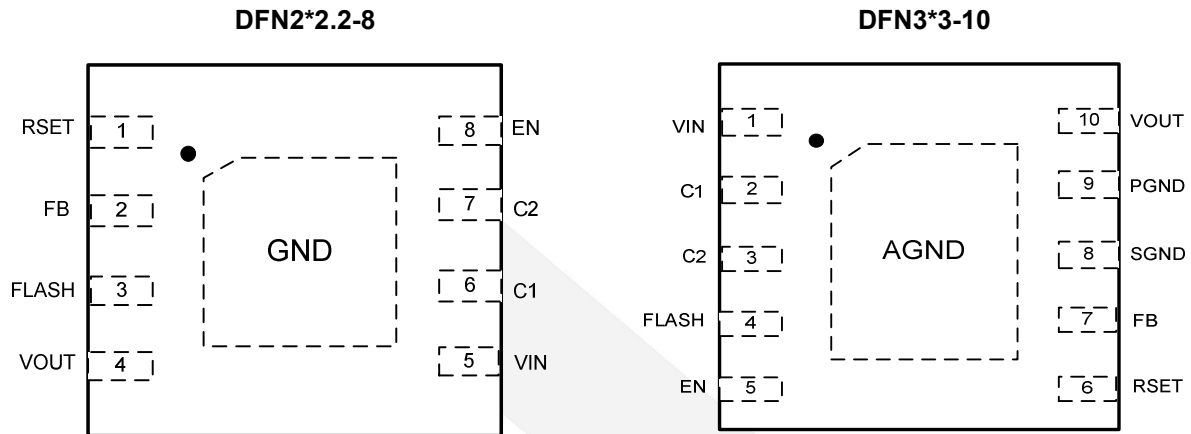

Figure 1 Pin Assignment (Top View)

Pin Descriptions

| Name | Description |
|-------|--|
| RSET | Connect a resistor from this pin to ground. When in FLASH mode (FLASH = High) this resistor sets the current regulation point according to the following: $V_{FB} = (1.26V / R_{SET}) \times 10.2K\Omega$. |
| FB | Feedback input for the current control loop. Connect directly to the current sense resistor. |
| FLASH | Logic input to toggle operation between FLASH and TORCH mode. In TORCH mode FB is regulated to the internal 47mV reference. In FLASH mode FB reference voltage can be adjusted by changing the resistor from R _{SET} pin to ground. Choose the external current sense resistor (R _{SENSE}) based on desired current in TORCH mode and Flash mode. |
| VOUT | Charge Pump Output Voltage. Decouple with an external capacitor. At least 1μF is recommended. If Higher value capacitor is used, output ripple is smaller. |
| VIN | Input voltage for the charge pump. Decouple with 4.7μF or 10μF ceramic capacitor close to the pins of the IC. |
| C1 | Positive input for the external flying capacitor. Connect a ceramic 1μF capacitor close to the pins of the IC. |
| C2 | Negative input for the external flying capacitor. Connect a ceramic 1μF capacitor close to the pins of the IC. |
| EN | Shutdown control input. Connect to VIN for normal operation, connect to ground for shutdown. |
| SGND | Internal ground pin. Control circuitry returns current to this pin. |
| PGND | Power ground pin. Flying capacitor current returns through this pin. |
| GND | Exposed pad should be soldered to PCB board and connected to GND. |



DIO5151B

700mA/1A Buck/Boost Charge Pump LED Driver

Absolute Maximum Ratings

Stresses beyond those listed under "Absolute Maximum Rating" may cause permanent damage to the device. These are stress ratings only and functional operation of the device at these or any other condition beyond those indicated in the operational sections of the specifications is not implied. Exposure to absolute maximum rating conditions for extended periods may affect device reliability.

| Parameter | | Rating | Unit |
|-----------------------------------|--------------|------------|------|
| Supply Voltage Range | | -0.3 to 6 | V |
| EN Input Voltage | | 0-5.5 | V |
| Output Current Pulse (Flash) | DIO5151BED8 | 700 | mA |
| | DIO5151BCD10 | 1 | A |
| Output Current Continuous (Torch) | | 0.4 | A |
| Junction Temperature | | 150 | °C |
| Storage Temperature | | -40 to 150 | °C |
| Lead Temperature (soldering, 10s) | | 260 | °C |
| ESD (HBM) ALL PINS | | 3500 | V |
| ESD (MM) | | 200 | V |

Recommend Operating Conditions

The Recommended Operating Conditions table defines the conditions for actual device operation. Recommended Operating conditions are specified to ensure optimal performance to the datasheet specifications. DIOO does not Recommend exceeding them or designing to Absolute Maximum Ratings.

| Parameter | Rating | Unit |
|-----------------------------|-----------|------|
| Input Supply Voltage | 3 to 5.5 | V |
| Operating Temperature Range | -40 to 85 | °C |



DIO5151B

700mA/1A Buck/Boost Charge Pump LED Driver

Electrical Characteristics

($V_{IN} = 3.6V$, $C_{IN} = 4.7\mu F$, $C_{OUT} = C_F = 1\mu F$, $V_{SHDN} = V_{IN}$, typical values at +25°C, unless otherwise noted.)

| Parameter | Symbol | Conditions | Min | Typ | Max | Unit |
|--|------------|---|-----|-----|-----|----------|
| Input Supply Voltage | V_{IN} | | 3 | | 5.5 | V |
| Quiescent Current | I_Q | $V_{IN} = 2.7V$ to $5.5V$, FLASH = 0V, $I_{LOAD} = 100\mu A$ | | 0.3 | | mA |
| Shutdown Current | I_{SHDN} | $V_{EN} = 0V$, $V_{IN} = 5.5V$ | | | 1 | μA |
| Oscillator Frequency | | | | 2 | | MHz |
| Charge Pump Equivalent Resistance (2×mode) | | | | 5 | | Ω |
| Charge Pump Equivalent Resistance (1×mode) | | | | 0.6 | | Ω |
| FB Reference Voltage | V_{FB} | FLASH = V_{IN} , $R_{SET} = 86.6K\Omega$ | 132 | 150 | 165 | mV |
| | | FLASH = GND | | 47 | | |
| FB Pin Current | | $V_{FB} = 0.3V$ | | | 1 | μA |
| EN, FLASH Logic Low | | | | | 0.4 | V |
| EN, FLASH Logic High | | $V_{IN} = 4.3V$ | 1.2 | | | V |
| EN, FLASH Pin Current | | | | 0.8 | | μA |
| V_{OUT} Turn-on Time | | $V_{IN} = 3.6V$, FB within 90% of regulation | | 350 | | μs |
| Thermal Shutdown Temperature | | | | 145 | | °C |

Specifications subject to changes without notice.

Typical Performance Characteristics

$C_{IN} = 10\mu F$, $C_{OUT} = 4.7\mu F$, $C_F = 1\mu F$, unless otherwise noted.

Ripple Torch mode 2X mode

($V_{IN}=3.6V$, $V_{LED}=2.9V$, $I_{LED}=200mA$)

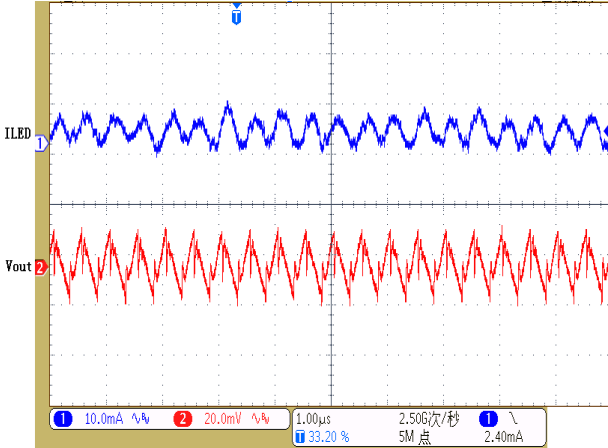

Ripple Torch mode 1X mode

($V_{IN}=4.2V$, $V_{LED}=2.9V$, $I_{LED}=200mA$)

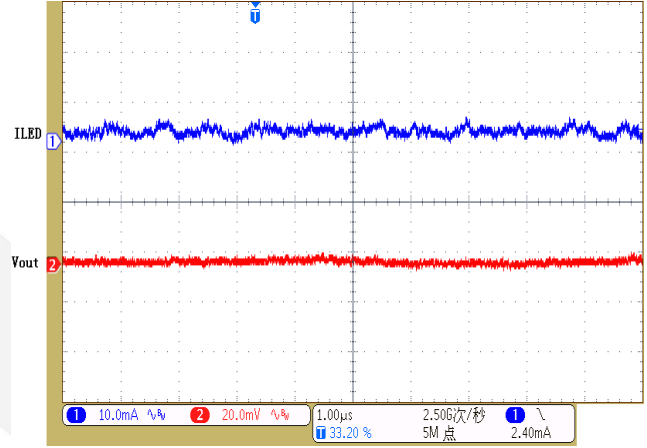

Ripple Torch mode 2X mode

($V_{IN}=3.6V$, $V_F=3.0V$, $I_{LED}=700mA$)

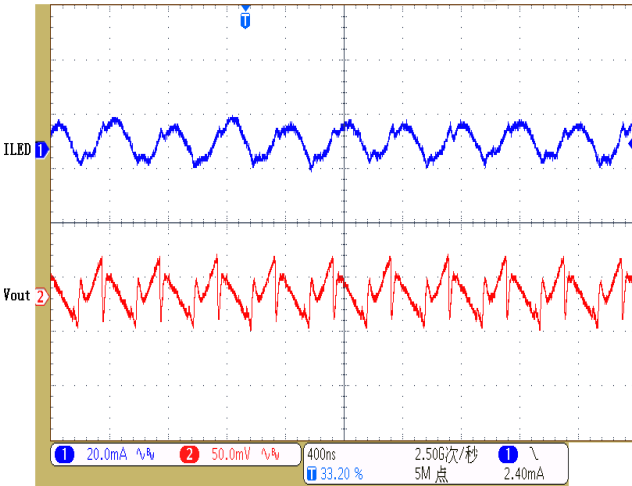

Ripple Torch mode 1X mode

($V_{IN}=4.2V$, $V_F=3.0V$, $I_{LED}=700mA$)

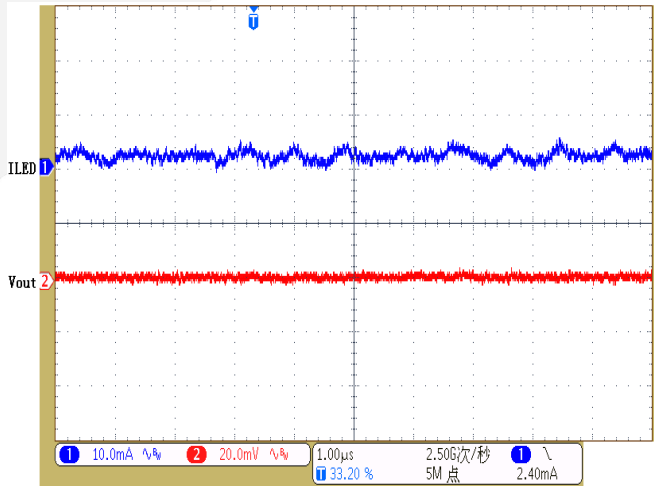

Start-up Touch mode

($V_{EN}=3.6V$, $V_F=2.9V$, $I_{LED}=200mA$)

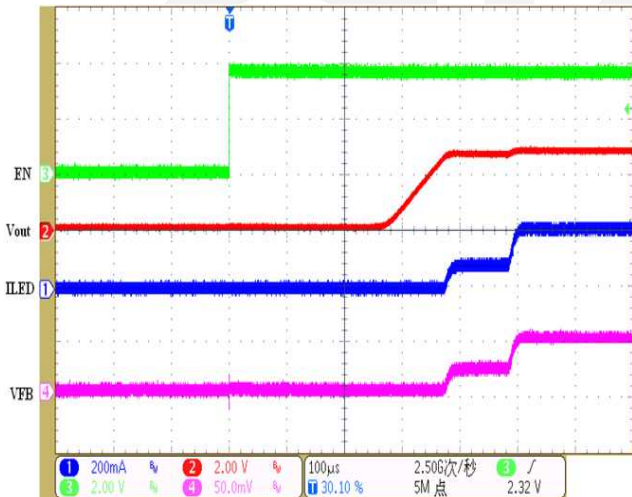

Start-up Flash mode

($V_{EN}=4.2V$, $V_F=3.0V$, $I_{LED}=700mA$)

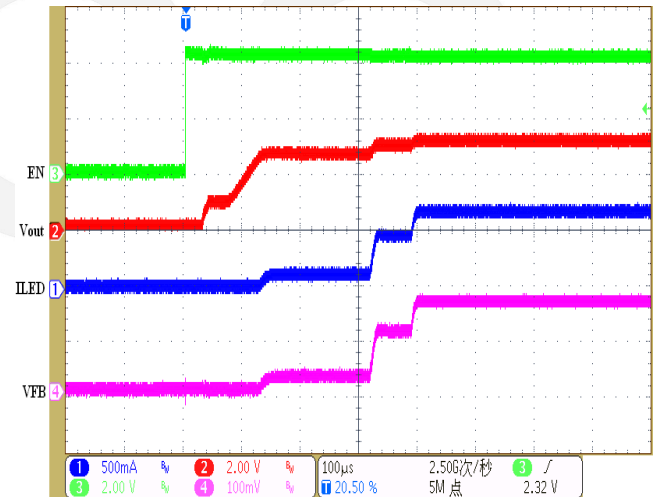

Torch mode to Flash mode

($V_{IN}=3.6V$)

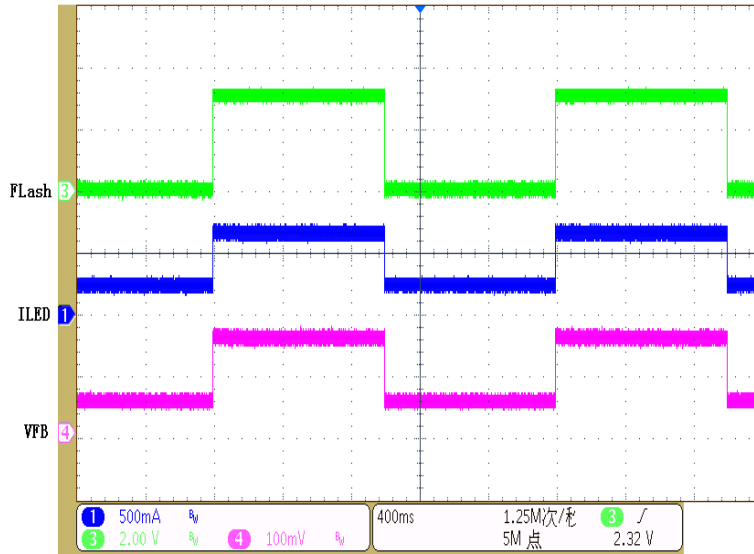

Flash Current Distribution

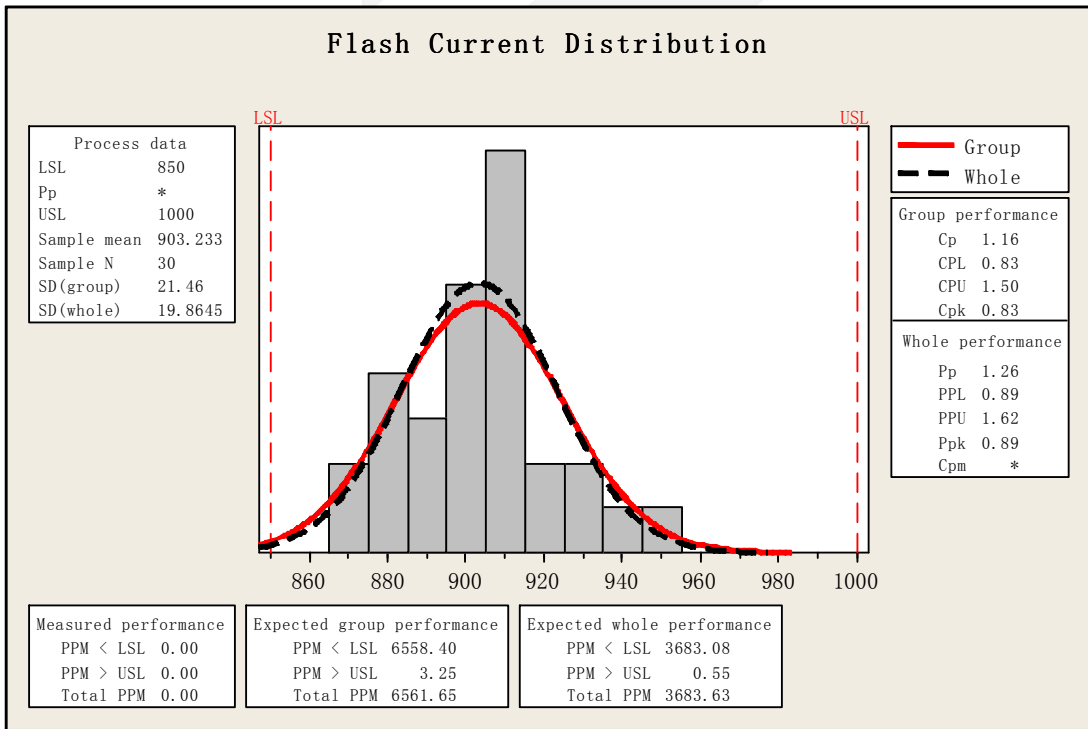

Typical Application

The DIO5151B can be used with multiple LEDs in parallel as shown in figure 2. For best performance, the LEDs should be in a single package, preferably from a single die to have better matching for forward voltage V_F for a given forward current I_F . In practice, if the V_F of one LED is higher than the others, it will consume a larger I_F , which will raise its temperature which will then cause its V_F to reduce, correcting the imbalance. The overall current will be the sum of the individual currents, for example $I_{TOTAL} = 4 \times I_{LED}$.

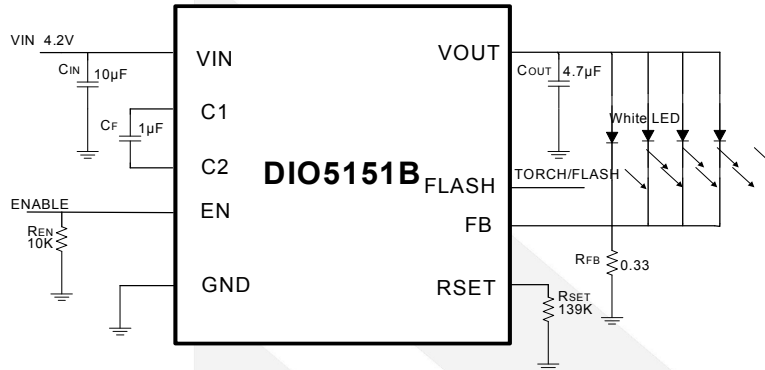

Figure 2. Multiple LEDs Flash Circuit

The DIO5151B also can be used to drive two flash LEDs in portable equipments. The schematic is shown in Figure 3.

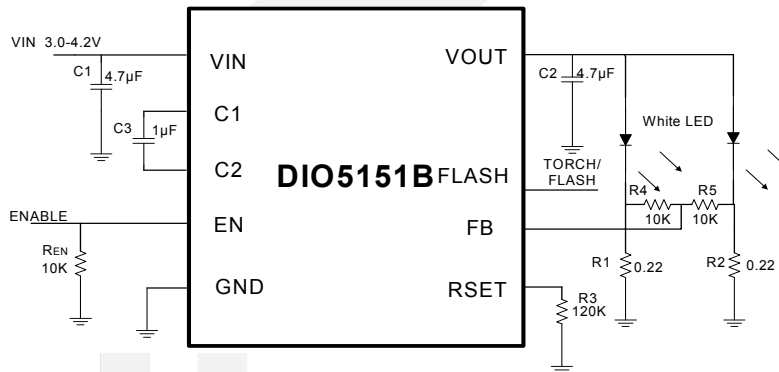

Figure 3. Two Flash LED Drive

Application Information

The DIO5151B is a charge pump regulator designed for converting a Li-Ion battery voltage of 3V to 4.3V to drive a white LED used in digital still camera Flash and Torch applications. The DIO5151B has two modes of operation which are pin selectable for either Flash or Torch. Both modes can be used continuously unless thermal shutdown happens. Torch is often used for several seconds in a digital still camera "movie" mode.

The DIO5151B also has two modes of operation to control the output current: the 1× mode and 2× mode. Operation begins after the enable pin EN receives a logic high, the band-gap reference wakes up after 50µs, and then DIO5151B goes through a soft-start mode designed to reduce inrush current. The DIO5151B starts in the 1× mode, which acts like a linear regulator to control the output current by continuously monitoring the feedback pin FB. In 1× mode, if the DIO5151B auto detects a dropout condition, which is when the FB pin is below the regulation point for more than 15µs, the DIO5151B automatically switches to the 2× mode. The DIO5151B remains in the 2× mode until one of four things happens:

- 1) The enable pin EN has been toggled.
- 2) The Flash pin has changed from high to low.
- 3) V_{IN} is cycled or V_{IN} is at least 1V above V_{OUT} .
- 4) A thermal fault occurs.

The 2× mode is the charge pump mode where the output can be pumped as high as two times the input voltage, provided the output does not exceed the maximum voltage for the DIO5151B, which is internally limited to about 5.5V. In the 2× mode, as in the 1× mode, the output current is regulated by the voltage at the FB pin. In the Torch mode, (Flash = “GND”) the Flash pin is set to logic low and the DIO5151B FB pin regulates to 47mV output:

$$V_{FB} = 47\text{mV (Torch Mode)}$$

When in Flash mode, (Flash = “High”), the FB regulation voltage is set by the resistor R_{SET} connected between the R_{SET} pin and SGND and the equation:

$$V_{FB} = (1.26\text{V} / R_{SET}) \times 10.2\text{K}\Omega \text{ (Flash Mode)}$$

Where 1.26V is the internal band-gap reference voltage and 10.2K Ω is an internal resistance used to scale the R_{SET} current. Typical values of R_{SET} are 42K Ω to 170K Ω for a range of $V_{FB} = 300\text{mV}$ to 75mV in Flash mode. The output current is then set in either Flash or Torch mode by the equation:

$$I_{OUT} = V_{FB} / R_{SENSE}$$

Over temperature Protection

When the temperature of DIO5151B rises above 145°C, the over temperature protection circuitry turns off the output switches to prevent damage to the device. If the temperature drops back down below 130°C, the part automatically recovers and executes a soft start cycle.

Overvoltage Protection

The DIO5151B has over voltage protection. If the output voltage rises above the 5.5V threshold, the over voltage protection shuts off all of the output switches to prevent the output voltage from rising further. When the output decreases below 5.2V, the device resumes normal operation.

Over-current Protection

The over current protection circuitry monitors the average current out of the $V_{OUT} = 47\text{mV}$ (Torch Mode) pin. If the average output current exceeds approximately 700mA/1A, then the over current protection circuitry shuts off the output switches to protect the chip.

Component Selection

The DIO5151B charge pump circuit requires 3 capacitors: 4.7 μF input, 1 μF output and 1 μF flying capacitors are typically recommended. For the input capacitor, a larger value of 10 μF will help reduce input voltage ripple for applications sensitive to ripple on the battery voltage. All the capacitors should be surface mount ceramic for low lead inductance necessary at the 2MHz switching frequency of the DIO5151B and to obtain low ESR, which improves bypassing on the input and output and improves output voltage drive by reducing output resistance. Ceramic capacitors with X5R or X7R temperature grade are recommended for most applications.

The input and output capacitors should be located as close to the V_{IN} and V_{OUT} pins as possible to obtain best bypassing, and the returns should be connected directly to the GND pin or to the thermal pad ground located

under the DIO5151B. The flying capacitor should be located as close to the C1 and C2 pins as possible. To obtain lower output ripple, the C_{OUT} value can be increased from $1\mu F$ to $2.2\mu F$ or $4.7\mu F$ with a corresponding decrease in output ripple. For output currents of 500mA to 700mA/1A, the recommended C_F flying capacitor value of $1\mu F$ should be used. Output currents in Flash of 100mA to 400mA can use a $0.47\mu F$ C_F but a minimum $1\mu F$ C_{OUT} is still needed.

Resistor Selection

The sense resistor R_{SENSE} is determined by the value needed in the Torch mode for the desired output current by the equation:

$$R_{SENSE} = V_{FB} / I_{OUT} \text{ where } V_{FB} = 47mV \text{ (Torch Mode)}$$

Once the R_{SENSE} resistor has been selected for Torch mode, the V_{FB} voltage can be selected for Flash mode using the following equation:

$$V_{FB} = I_{OUT} \times R_{SENSE} \text{ (Flash Mode) where } I_{OUT} \text{ is for Flash Mode.}$$

Next, the R_{SET} resistor can be selected for Flash mode using the following equation:

$$R_{SET} = (1.26V / V_{FB}) \times 10.2K\Omega \text{ (Flash Mode)}$$

For an example of 190mA Torch mode and 600mA Flash mode, the values $R_{SENSE} = 0.25\Omega$, $V_{FB} = 150mV$ (Flash Mode), and $R_{SET} = 86.6K\Omega$ are calculated. The power obtained in the Flash mode would be:

$$P_{FLASH} = V_{FB} \times I_{OUT} = 150mV \times 600mA = 90mW.$$

The typical 0603 surface mount resistor is rated 1/10 Watt continuous power and 1/5 Watt pulsed power, more than enough for this application. For other applications, the P_{FLASH} power can be calculated and resistor size selected. The R_{SENSE} resistor is recommended to be size 0603 for most applications. The range of typical resistor values and sizes are shown here in Table 1.

Table 1: Resistor values and sizes

| PART REFERENCE | VALUE | TOLERANCE | SIZE | MANUFACTURERS |
|--------------------|-------|-----------|------|---------------------|
| R _{SET} | 68KΩ | 1% | 0402 | any |
| R _{SET} | 75KΩ | 1% | 0402 | any |
| R _{SET} | 82KΩ | 1% | 0402 | any |
| R _{SET} | 91KΩ | 1% | 0402 | any |
| R _{SET} | 100KΩ | 1% | 0402 | any |
| R _{SET} | 110KΩ | 1% | 0402 | any |
| R _{SET} | 120KΩ | 1% | 0402 | any |
| R _{SET} | 130KΩ | 1% | 0402 | any |
| R _{SET} | 140KΩ | 1% | 0402 | any |
| R _{SET} | 150KΩ | 1% | 0402 | any |
| R _{SENSE} | 0.22Ω | 1% | 0603 | Panasonic or Vishay |
| R _{SENSE} | 0.27Ω | 1% | 0603 | Panasonic or Vishay |
| R _{SENSE} | 0.33Ω | 1% | 0603 | Panasonic or Vishay |
| R _{SENSE} | 0.39Ω | 1% | 0603 | Panasonic or Vishay |
| R _{SENSE} | 0.47Ω | 1% | 0603 | Panasonic or Vishay |

Physical Dimensions: DFN2*2.2-8

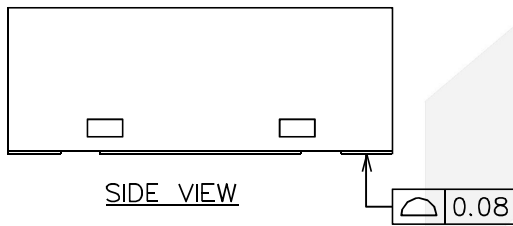
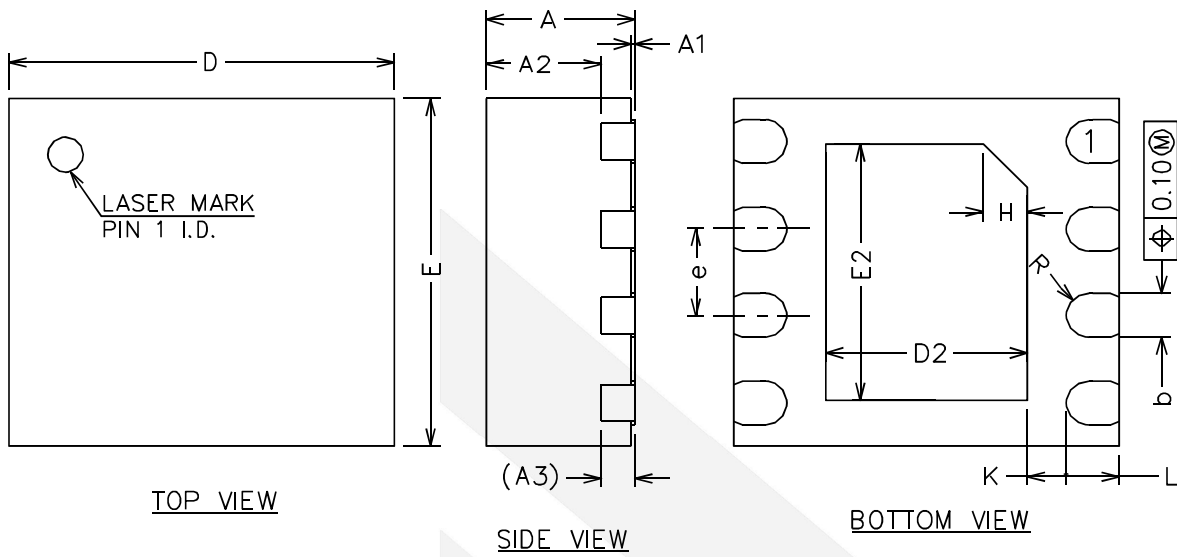

| COMMON DIMENSIONS (UNITS OF MEASURE=MILLIMETER) | | | |
|--|---------|-------|-------|
| Symbol | MIN | NOM | MAX |
| A | 0.8 | 0.85 | 0.90 |
| A1 | 0 | 0.02 | 0.05 |
| A2 | 0.6 | 0.65 | 0.70 |
| A3 | 0.20REF | | |
| b | 0.2 | 0.25 | 0.3 |
| D | 2.10 | 2.20 | 2.30 |
| E | 1.90 | 2.00 | 2.10 |
| D2 | 1.05 | 1.15 | 1.25 |
| E2 | 1.38 | 1.48 | 1.58 |
| e | 0.40 | 0.50 | 0.60 |
| H | 0.25REF | | |
| K | 0.125 | 0.225 | 0.325 |
| L | 0.25 | 0.30 | 0.35 |
| R | 0.11 | - | - |

Physical Dimensions: DFN3*3-10

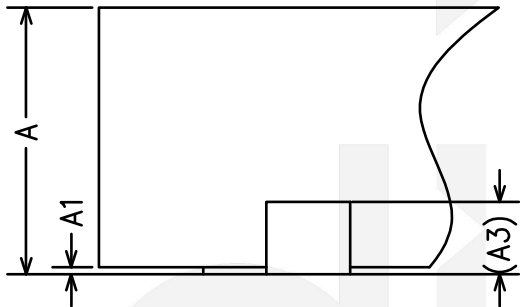
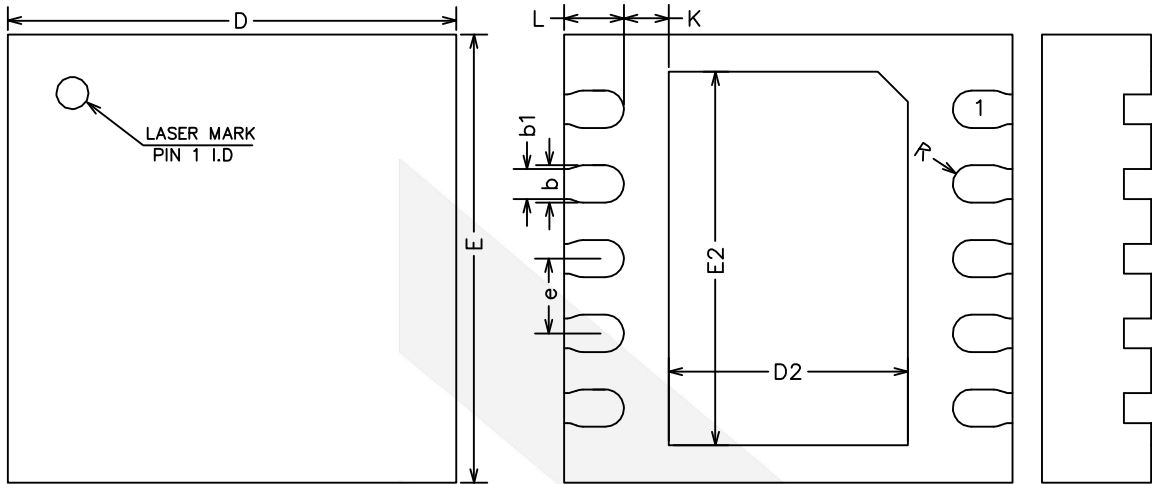

| COMMON DIMENSIONS (UNITS OF MEASURE=MILLIMETER) | | | |
|--|---------|------|------|
| Symbol | MIN | NOM | MAX |
| A | 0.70 | 0.75 | 0.80 |
| A1 | 0 | 0.02 | 0.05 |
| A3 | 0.20REF | | |
| b | 0.20 | 0.25 | 0.30 |
| b1 | 0.20REF | | |
| D | 2.90 | 3.00 | 3.10 |
| E | 2.90 | 3.00 | 3.10 |
| D2 | 1.50 | 1.60 | 1.70 |
| E2 | 2.40 | 2.50 | 2.60 |
| e | 0.40 | 0.50 | 0.60 |
| K | 0.20 | - | - |
| L | 0.30 | 0.40 | 0.50 |
| R | 0.13 | - | - |



DIO5151B

700mA/1A Buck/Boost Charge Pump LED Driver

CONTACT US

Dioo is a professional design and sales corporation for high-quality and performance analog semiconductors. The company focuses on industry markets, such as, cell phone, handheld products, laptop, and medical equipment and so on. Dioo's product families include analog signal processing and amplifying, LED drivers and charger IC. Go to <http://www.dioo.com> for a complete list of Dioo product families.

For additional product information, or full datasheet, please contact with our Sales Department or Representatives.





Компания «ЭлектроПласт» предлагает заключение долгосрочных отношений при поставках импортных электронных компонентов на взаимовыгодных условиях!

Наши преимущества:

- Оперативные поставки широкого спектра электронных компонентов отечественного и импортного производства напрямую от производителей и с крупнейших мировых складов;
- Поставка более 17-ти миллионов наименований электронных компонентов;
- Поставка сложных, дефицитных, либо снятых с производства позиций;
- Оперативные сроки поставки под заказ (от 5 рабочих дней);
- Экспресс доставка в любую точку России;
- Техническая поддержка проекта, помощь в подборе аналогов, поставка прототипов;
- Система менеджмента качества сертифицирована по Международному стандарту ISO 9001;
- Лицензия ФСБ на осуществление работ с использованием сведений, составляющих государственную тайну;
- Поставка специализированных компонентов (Xilinx, Altera, Analog Devices, Intersil, Interpoint, Microsemi, Aeroflex, Peregrine, Syfer, Eurofarad, Texas Instrument, Miteq, Cobham, E2V, MA-COM, Hittite, Mini-Circuits, General Dynamics и др.);

Помимо этого, одним из направлений компании «ЭлектроПласт» является направление «Источники питания». Мы предлагаем Вам помощь Конструкторского отдела:

- Подбор оптимального решения, техническое обоснование при выборе компонента;
- Подбор аналогов;
- Консультации по применению компонента;
- Поставка образцов и прототипов;
- Техническая поддержка проекта;
- Защита от снятия компонента с производства.



Как с нами связаться

Телефон: 8 (812) 309 58 32 (многоканальный)

Факс: 8 (812) 320-02-42

Электронная почта: org@eplast1.ru

Адрес: 198099, г. Санкт-Петербург, ул. Калинина, дом 2, корпус 4, литера А.