

AT-213-PIN



Digital Attenuator
15.0 dB, 4-Bit, TTL Driver, DC-3.0 GHz

Rev. V5

Features

- Attenuation: 1 dB steps to 15 dB
- Temperature Stability: ± 0.18 dB from -55°C to $+85^{\circ}\text{C}$ Typical
- Low DC Power Consumption
- Hermetic Surface Mount Package
- Integral TTL Driver
- 50 Ohms Nominal Impedance
- Lead-Free CR-11 Package
- 260°C Reflow Compatible
- RoHS* Compliant

Description

M/A-COM's AT-213-PIN is a 4-bit, 1 dB step digital attenuator in a hermetically sealed ceramic 16-lead surface mount package. The AT-213-PIN is ideally suited for use where high accuracy, fast switching, very low power consumption and low intermodulation products are required. Typical applications include dynamic range setting in a precision receiver circuits and other gain/leveling control circuits. Environmental screening is available. Contact the factory for information.

Functional Schematic

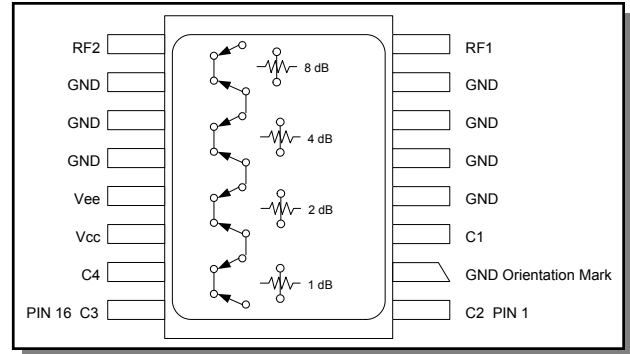

Ordering Information

Part Number	Package
AT-213-PIN	Bulk Packaging

Note: Reference Application Note M513 for reel size information.

Pin Configuration

Pin No.	Function	Pin No.	Function
1	C2	9	RF2
2	GND	10	GND
3	C1	11	GND
4	GND	12	GND
5	GND	13	Vee
6	GND	14	Vcc
7	GND	15	C4
8	RF1	16	C3

The metal bottom of the case must be connected to RF and DC ground.

* Restrictions on Hazardous Substances, European Union Directive 2002/95/EC.

Electrical Specifications: $T_A = -55^{\circ}\text{C}$ to $+85^{\circ}\text{C}$ ¹

Parameter	Test Conditions	Frequency	Units	Min	Typ	Max
Reference Insertion Loss	—	DC - 0.5 GHz	dB	—	—	1.7
		DC - 1.0 GHz	dB	—	—	1.9
		DC - 2.0 GHz	dB	—	—	2.2
		DC - 3.0 GHz	dB	—	—	2.5
Attenuation Accuracy ²	Any Single Bit	DC - 2.0 GHz DC - 3.0 GHz	± (0.15 dB +3% of atten setting in dB) dB ± (0.2 dB +3% of atten setting in dB) dB Or ± 0.4 dB, whichever is greater			
	Any Combination of Bits	DC - 2.0 GHz DC - 3.0 GHz	± (0.2 dB +3% of atten setting in dB) dB ± (0.2 dB +3% of atten setting in dB) dB Or ± 0.4 dB, whichever is greater			
VSWR	—	—	Ratio	—	—	1.6:1
Trise, Tfall	10% to 90%	—	ns	—	9	—
Ton, Toff	50% Control to 90/10% RF	—	ns	—	40	—
Transients	In-Band (peak-peak)	—	mV	—	30	—
1 dB Compression	Input Power Input Power	0.05 GHz	dBm	—	+22	—
		0.5 - 3.0 GHz	dBm	—	+28	—
Input IP3	For two-tone Input Power Up to +5 dBm	0.05 GHz	dBm	—	+40	—
		0.5 - 3.0 GHz	dBm	—	+50	—
Input IP2	For two-tone Input Power Up to +5 dBm	0.05 GHz	dBm	—	+45	—
		0.5 - 3.0 GHz	dBm	—	+68	—
Vcc	—	—	V	4.5	5.0	5.5
Vee	—	—	V	-8.0	—	-5.0
Icc	Vcc = 4.5 to 5.5V Vctl = 0 to 0.8V, or Vcc – 2.1V to Vcc	—	mA	—	—	4.0
Iee	Vee = -5.0 to -8.0V	—	mA	—	—	1.0
Vctl	Logic 0 (TTL)	—	V	0.0	—	0.8
	Logic 1 (TTL)	—	V	2.0	—	5.0
Input Leakage Current (Low)	0 to 0.8V	—	µA	—	—	1.0
Input Leakage Current (High)	2.0 to 5.0V	—	µA	—	—	1.0

1. All specifications apply when operated with bias voltages of +5V for Vcc and –5.0V for Vee.
2. This attenuator is guaranteed monotonic.

Absolute Maximum Ratings ^{3,4}

Parameter	Absolute Maximum
Max Input Power 0.5 GHz 0.5 - 3.0 GHz	+27 dBm +34 dBm
V_{CC}	$-0.5V \leq V_{CC} \leq +7.0V$
V_{EE}	$-8.5V \leq V_{EE} \leq +0.5V$
$V_{CC} - V_{EE}$	$-0.5V \leq V_{CC} - V_{EE} \leq 14.5V$
V_{in}^5	$-0.5V \leq V_{in} \leq V_{CC} + 0.5V$
Operating Temperature	$-55^{\circ}C$ to $+125^{\circ}C$
Storage Temperature	$-65^{\circ}C$ to $+150^{\circ}C$

- Exceeding any one or combination of these limits may cause permanent damage to this device.
- M/A-COM does not recommend sustained operation near these survivability limits.
- Standard CMOS TTL interface, latch-up will occur if logic signal is applied prior to power supply.

Handling Procedures

Please observe the following precautions to avoid damage:

Static Sensitivity

Gallium Arsenide Integrated Circuits are sensitive to electrostatic discharge (ESD) and can be damaged by static electricity. Proper ESD control techniques should be used when handling these devices.

Truth Table (Digital Attenuator)

Control Inputs				
C4	C3	C2	C1	Attenuation
0	0	0	0	Reference
0	0	0	1	1 dB
0	0	1	0	2 dB
0	1	0	0	4 dB
1	0	0	0	8 dB
1	1	1	1	15 dB

0 = TTL Low; 1 = TTL High

Typical Performance Curves

Ref. Insertion Loss vs. Frequency

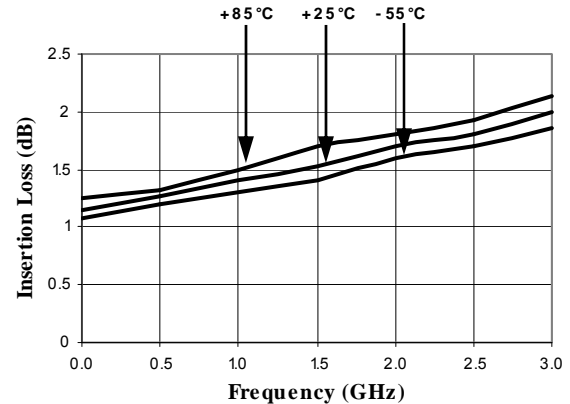

Attenuation Accuracy vs. Frequency

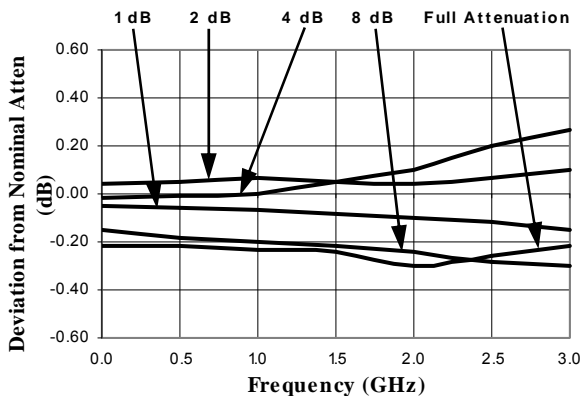

RF1 VSWR vs. Frequency

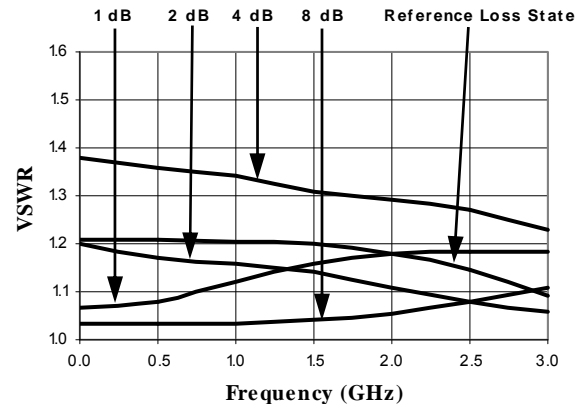

AT-213-PIN



Digital Attenuator
15.0 dB, 4-Bit, TTL Driver, DC-3.0 GHz

Rev. V5

Typical Performance Curves

RF2 VSWR vs. Frequency

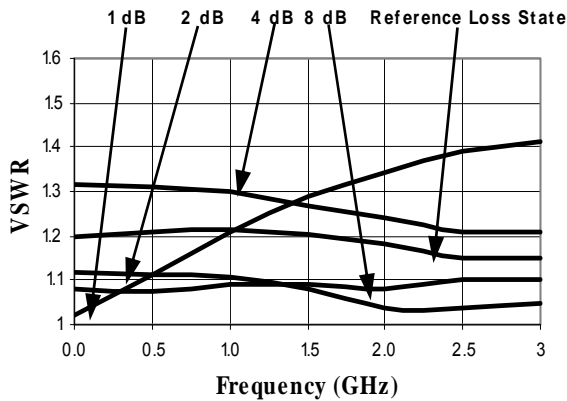

Lead-Free, CR-11 Ceramic Package†

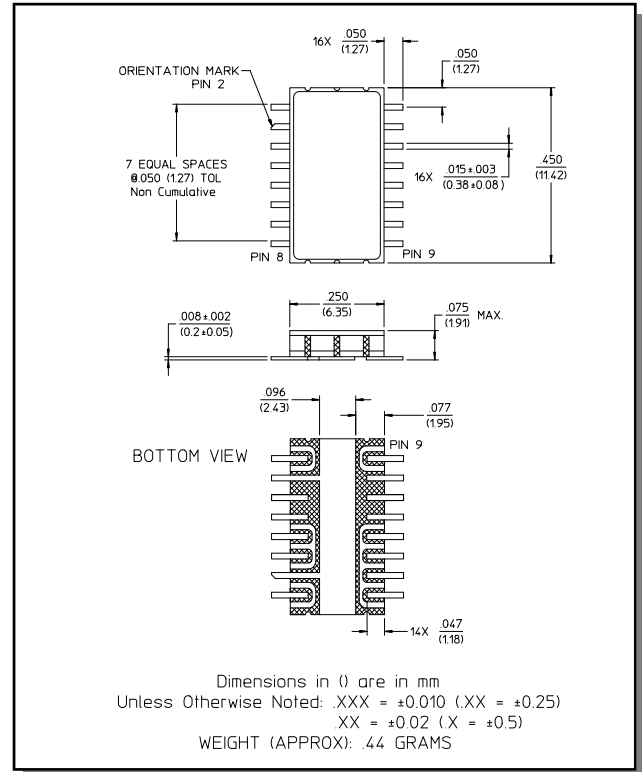

† Reference Application Note M538 for lead-free solder reflow recommendations.



Компания «ЭлектроПласт» предлагает заключение долгосрочных отношений при поставках импортных электронных компонентов на взаимовыгодных условиях!

Наши преимущества:

- Оперативные поставки широкого спектра электронных компонентов отечественного и импортного производства напрямую от производителей и с крупнейших мировых складов;
- Поставка более 17-ти миллионов наименований электронных компонентов;
- Поставка сложных, дефицитных, либо снятых с производства позиций;
- Оперативные сроки поставки под заказ (от 5 рабочих дней);
- Экспресс доставка в любую точку России;
- Техническая поддержка проекта, помощь в подборе аналогов, поставка прототипов;
- Система менеджмента качества сертифицирована по Международному стандарту ISO 9001;
- Лицензия ФСБ на осуществление работ с использованием сведений, составляющих государственную тайну;
- Поставка специализированных компонентов (Xilinx, Altera, Analog Devices, Intersil, Interpoint, Microsemi, Aeroflex, Peregrine, Syfer, Eurofarad, Texas Instrument, Miteq, Cobham, E2V, MA-COM, Hittite, Mini-Circuits, General Dynamics и др.);

Помимо этого, одним из направлений компании «ЭлектроПласт» является направление «Источники питания». Мы предлагаем Вам помощь Конструкторского отдела:

- Подбор оптимального решения, техническое обоснование при выборе компонента;
- Подбор аналогов;
- Консультации по применению компонента;
- Поставка образцов и прототипов;
- Техническая поддержка проекта;
- Защита от снятия компонента с производства.



Как с нами связаться

Телефон: 8 (812) 309 58 32 (многоканальный)

Факс: 8 (812) 320-02-42

Электронная почта: org@eplast1.ru

Адрес: 198099, г. Санкт-Петербург, ул. Калинина, дом 2, корпус 4, литера А.