

**UG0726**  
**User Guide**  
**PolarFire FPGA Board Design**



---

a  **MICROCHIP** company



a  MICROCHIP company

**Microsemi Headquarters**

One Enterprise, Aliso Viejo,  
CA 92656 USA

Within the USA: +1 (800) 713-4113

Outside the USA: +1 (949) 380-6100

Sales: +1 (949) 380-6136

Fax: +1 (949) 215-4996

Email: [sales.support@microsemi.com](mailto:sales.support@microsemi.com)

[www.microsemi.com](http://www.microsemi.com)

©2019 Microsemi, a wholly owned subsidiary of Microchip Technology Inc. All rights reserved. Microsemi and the Microsemi logo are registered trademarks of Microsemi Corporation. All other trademarks and service marks are the property of their respective owners.

Microsemi makes no warranty, representation, or guarantee regarding the information contained herein or the suitability of its products and services for any particular purpose, nor does Microsemi assume any liability whatsoever arising out of the application or use of any product or circuit. The products sold hereunder and any other products sold by Microsemi have been subject to limited testing and should not be used in conjunction with mission-critical equipment or applications. Any performance specifications are believed to be reliable but are not verified, and Buyer must conduct and complete all performance and other testing of the products, alone and together with, or installed in, any end-products. Buyer shall not rely on any data and performance specifications or parameters provided by Microsemi. It is the Buyer's responsibility to independently determine suitability of any products and to test and verify the same. The information provided by Microsemi hereunder is provided "as is, where is" and with all faults, and the entire risk associated with such information is entirely with the Buyer. Microsemi does not grant, explicitly or implicitly, to any party any patent rights, licenses, or any other IP rights, whether with regard to such information itself or anything described by such information. Information provided in this document is proprietary to Microsemi, and Microsemi reserves the right to make any changes to the information in this document or to any products and services at any time without notice.

**About Microsemi**

Microsemi, a wholly owned subsidiary of Microchip Technology Inc. (Nasdaq: MCHP), offers a comprehensive portfolio of semiconductor and system solutions for aerospace & defense, communications, data center and industrial markets. Products include high-performance and radiation-hardened analog mixed-signal integrated circuits, FPGAs, SoCs and ASICs; power management products; timing and synchronization devices and precise time solutions, setting the world's standard for time; voice processing devices; RF solutions; discrete components; enterprise storage and communication solutions, security technologies and scalable anti-tamper products; Ethernet solutions; Power-over-Ethernet ICs and midspans; as well as custom design capabilities and services. Learn more at [www.microsemi.com](http://www.microsemi.com).

# Contents

---

<b>1</b>	<b>Revision History</b>	<b>1</b>
1.1	Revision 8.0	1
1.2	Revision 7.0	1
1.3	Revision 6.0	1
1.4	Revision 5.0	1
1.5	Revision 4.0	2
1.6	Revision 3.0	2
1.7	Revision 2.0	2
1.8	Revision 1.0	2
<b>2</b>	<b>PolarFire FPGA Board Design</b>	<b>3</b>
2.1	Designing the Board	3
2.2	Power Supplies	4
2.2.1	PolarFire Decoupling Capacitors	5
2.2.2	Power-Supply Topology	11
2.2.3	Unused Power Supply	13
2.2.4	Pin Assignment Tables	14
2.3	I/O Glitch	14
2.4	User I/O	15
2.4.1	Cold Sparing	15
2.4.2	Hot Socketing (GPIO Only)	15
2.5	Clocks	16
2.6	Reset	16
2.7	DDR	18
2.8	Device Programming	18
2.8.1	JTAG Programming	18
2.8.2	SPI Master Mode Programming	19
2.8.3	SPI Slave Mode Programming	20
2.8.4	Special Pins	20
2.9	Transceiver	21
2.9.1	Reference Clock	21
2.10	MIPI Hardware Design Guidelines	21
2.10.1	MIPI RX	21
2.10.2	MIPI TX	22
2.11	AC and DC Coupling	23
2.12	Brownout Detection	23
<b>3</b>	<b>Board Design Checklist</b>	<b>24</b>
3.1	Prerequisites	24
3.2	Design Checklist	24
3.3	Layout Checklist	26
<b>4</b>	<b>Appendix: General Layout Design Practices</b>	<b>28</b>
4.1	MIPI	28
4.2	Transceiver	29
4.2.1	Layout Considerations	29
4.2.2	DC Blocking Capacitors	31

# Figures

---

Figure 1	Power Supplies . . . . .	4
Figure 2	Example Power-Supply Topology . . . . .	12
Figure 3	Option 1 for Unused Connections . . . . .	13
Figure 4	Option 2 for Unused Connections . . . . .	14
Figure 5	Cold Sparing . . . . .	15
Figure 6	JTAG Programming . . . . .	18
Figure 7	SPI Master Mode Programming . . . . .	19
Figure 8	SPI Slave Mode Programming . . . . .	20
Figure 9	MIPI RX Connection . . . . .	22
Figure 10	MIPI TX Connections . . . . .	22
Figure 11	MIPI TX Layout . . . . .	28
Figure 12	Skew Matching . . . . .	29
Figure 13	Example of Asymmetric and Symmetric Differential Pairs Structure . . . . .	29
Figure 14	Ground Planes for Reference . . . . .	30
Figure 15	Via Illustration . . . . .	30
Figure 16	Non-Functional Pads of Via . . . . .	31
Figure 17	Via-to-Via Pitch . . . . .	31
Figure 18	GND Via or Return Via . . . . .	31
Figure 19	Capacitor Pad Reference Plane . . . . .	32

# Tables

---

Table 1	Supply Pins	4
Table 2	Power-Supply Decoupling Capacitors—MPF500T - FCG1152/FCG784 (1mm)	5
Table 3	Power-Supply Decoupling Capacitors—MPF300T - FCG1152/FCG784/FCG484 (1 mm)	6
Table 4	Power-Supply Decoupling Capacitors—MPF300T - FCVG484 (0.8mm)	6
Table 5	Power-Supply Decoupling Capacitors—MPF300T - FCVG536 (0.5mm)	7
Table 6	Power-Supply Decoupling Capacitors—MPF200T - FCG784/FCG484 (1mm)	7
Table 7	Power-Supply Decoupling Capacitors—MPF200T - FCVG484 (0.8 mm)	8
Table 8	Power-Supply Decoupling Capacitors—MPF200T - FCVG536 (0.5 mm)	8
Table 9	Power-Supply Decoupling Capacitors—MPF200T - FCVG325 (0.5 mm)	9
Table 10	Power-Supply Decoupling Capacitors—MPF100T - FCVG325 (0.5 mm)	9
Table 11	Power-Supply Decoupling Capacitors—MPF100T - FCVG484 (0.8 mm)	10
Table 12	Power-Supply Decoupling Capacitors—MPF100T - FCG484 (1 mm)	10
Table 13	Recommended Decoupling Capacitors For PolarFire Devices	11
Table 14	Power Regulators	12
Table 15	Over-Voltage Tolerance	16
Table 16	RC Oscillator Count	16
Table 17	JTAG Pins	18
Table 18	SPI Master Mode Programming Pins	19
Table 19	Transceiver Support in PolarFire Devices	21
Table 20	Design Checklist	24
Table 21	Layout Checklist	26

# 1 Revision History

---

The revision history describes the changes that were implemented in the document. The changes are listed by revision, starting with the current publication.

## 1.1 Revision 8.0

The following is a summary of changes made in this revision.

- Updated the glitch information in [I/O Glitch](#), page 14.
- Added more information on the VDDI and VDDAUX in [Power Supplies](#), page 4.

## 1.2 Revision 7.0

The following is a summary of the changes made in this revision:

- Added [MIPI Hardware Design Guidelines](#), page 21.
- Added reset guidelines in [Reset](#), page 16.
- Added power-supply decoupling capacitors for the following device packages:
  - MPF200T-FCG484 (0.8 mm), see [Table 7](#), page 8.
  - MPF200T-FCSG536 (0.5 mm), see [Table 8](#), page 8.
  - MPF200T-FCG325 (0.5 mm), see [Table 9](#), page 9.
  - MPF100T-FCG325 (0.5 mm), see [Table 10](#), page 9.
  - MPF100T-FCG484 (0.8 mm), see [Table 11](#), page 10.

## 1.3 Revision 6.0

The following is a summary of the changes made in revision 6.0 of this document:

- Reference Voltage ( $V_{REFx}$ ) information updated in [Power Supplies](#), page 4.
- Added basic information about [Pin Assignment Tables](#), page 14.
- Power-Supply Decoupling Capacitors—MPF300T - FCG1152/FCG784/FCG484 updated in [Table 3](#), page 6.
- Power-Supply Decoupling Capacitors—MPF500T - FCG1152/FCG784 (1mm), Power-Supply Decoupling Capacitors—MPF200T - FCG784/FCG484 (1mm), and MPF100T - FCG484 (1mm) added in [Table 2](#), page 5, [Table 6](#), page 7, and [Table 12](#), page 10 respectively.
- Added [MIPI Hardware Design Guidelines](#), page 21.
- Added [Reset](#), page 16.

## 1.4 Revision 5.0

The following is a summary of the changes made in revision 5.0 of this document:

- Details of power supply decoupling capacitors for MPF300-FCG1152, MPF300-FCG484, MPF300-FCG784, MPF300-FCVG484, and MPF300-FCSG536 devices were updated. For more information, see [Table 3](#), page 6, [Table 4](#), page 6, and [Table 5](#), page 7.
- XCVR\_REF and VDD\_XCVR\_CLK supply pins details were added. For more information, see [Power Supplies](#), page 4).
- Information about VDDIx and VDDAUXx power supplies was updated. For more information, see [Unused Power Supply](#), page 13.
- A note about the power supply constraint of VDDI3 and VDD\_XCVR\_CLK pins was added. For more information, see [Power Supplies](#), page 4.
- Details of decoupling capacitors in PolarFire devices were added. For more information, see [Table 13](#), page 11.
- Additional information about VDDIx, VDDAUXx, and VDD\_XCVR\_CLK pins was added. For more information, see [Unused Power Supply](#), page 13.
- The design checklist for XCVR pins was updated. For more information, see [Table 20](#), page 24.
- Information about VREF was added to core power supply operation details. For more information, see [Power Supplies](#), page 4.
- Information about cold sparing was updated. For more information, see [Cold Sparing](#), page 15.

- JTAG pin details were updated. For more information, see [Table 17](#), page 18.
- The SPI master mode programming connectivity diagram was updated. For more information, see [Figure 7](#), page 19.
- Information about device reset was updated. For more information, see [Reset](#), page 16.
- DDR3 and DDR4 placement and routing guidelines were removed. These guidelines are available in [UG0676: PolarFire FPGA DDR Memory Controller User Guide](#).

## 1.5 Revision 4.0

Revision 4.0 was published in September 2017. The sections *Termination Schemes* and *PCB Capacitor Placement and Mounting Techniques* were removed from this document.

## 1.6 Revision 3.0

Following is a summary of changes made in revision 3.0 of this document:

- Added the Board Design Checklist chapter. For more information, see [Board Design Checklist](#), page 24.
- Added the [Special Pins](#), page 20 section in the [PolarFire FPGA Board Design](#), page 3 chapter.
- Updated the Power-up sequence for core supplies. For more information, see [Power Supplies](#), page 4 and [Power-Supply Topology](#), page 11.
- Removed a note related to XCVR\_TX and RX signals under the [Unused Power Supply](#), page 13 section.
- Updated the VDDI pin name from VDDIx to VDDI3 in the Device Programming section. For more information, see [Device Programming](#), page 18.

## 1.7 Revision 2.0

Following was a summary of changes made in revision 2.0 of this document:

- Values in the Power-Supply Decoupling Capacitors—MPF300-FCG484 table were updated.
- Values and parameters were updated in the SPI Master Mode Programming Pins table. For more information, see [Table 18](#), page 19.
- Updated Figure 2. For more information, see [Figure 2](#), page 12.

## 1.8 Revision 1.0

The first publication of this document.

## 2 PolarFire FPGA Board Design

---

Good board design practices are required to achieve expected performance from both PCBs and PolarFire® devices. High-quality and reliable results depend on minimizing noise levels, preserving signal integrity, meeting impedance and power requirements, and using appropriate transceiver protocols. These guidelines must be treated as a supplement to the standard board-level design practices.

This document is intended for readers who are familiar with the PolarFire device, experienced in digital board design, and know about the electrical characteristics of systems. It discusses power supplies, high-speed interfaces, various control interfaces, and the associated peripheral components of PolarFire FPGAs.

### 2.1 Designing the Board

PolarFire FPGAs are flash-based FPGAs that support various high-speed memory interfaces such as DDR3/DDR4, lowest power 12.7 Gbps transceiver (XCVR), built-in low-power dual PCIe Gen2, and fabric I/O such as high-speed I/O (HSIO) and general-purpose I/O (GPIO).

Subsequent sections discuss the following:

- [Power Supplies](#), page 4
- [User I/O](#), page 15
- [Clocks](#), page 16
- [Reset](#), page 16
- [Device Programming](#), page 18
- [Transceiver](#), page 21
- [AC and DC Coupling](#), page 23
- [Brownout Detection](#), page 23



## 2.2 Power Supplies

The following illustration shows the typical power supply requirements for PolarFire devices, and the recommended connections of power rails when every part of the device is used in a system. For information on decoupling capacitors associated with individual power supplies, see [PolarFire Decoupling Capacitors](#), page 5.

**Figure 1 • Power Supplies**

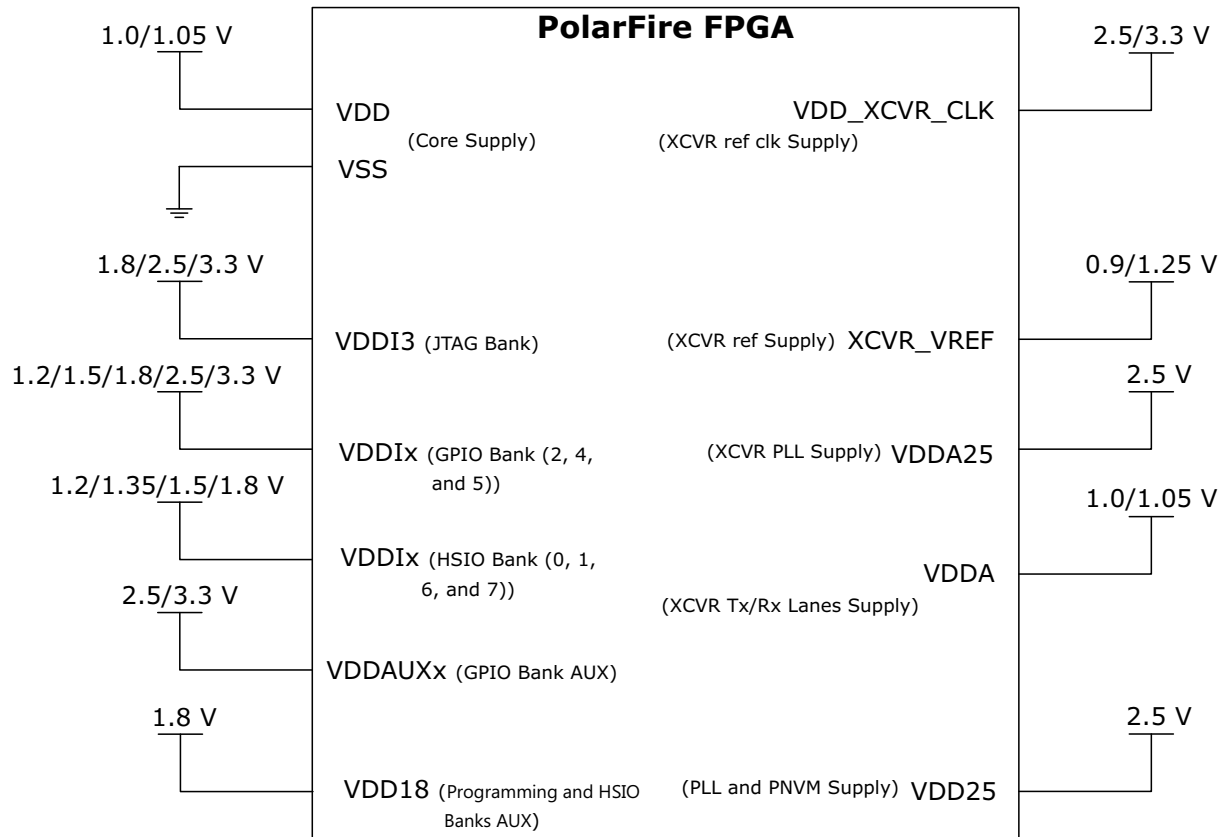

For the device to operate successfully, power supplies must be free from unregulated spikes and the associated grounds must be free from noise. All overshoots and undershoots must be within the absolute maximum ratings provided in the [DS0141: PolarFire FPGA Datasheet](#).

The following table lists the various power supplies required for PolarFire FPGAs.

**Table 1 • Supply Pins**

Name	Description
XCVR_VREF	Voltage reference for transceivers
VDD_XCVR_CLK	Power to input buffers for the transceiver reference clock
VDDA25	Power to the transceiver PLL
VDDA	Power to the transceiver TX and RX lanes
VSS	Core digital ground
VDD	Device core digital supply
VDDI3 (JTAG Bank)	Power to JTAG bank pins

**Table 1 • Supply Pins (continued)**

Name	Description
VDDIx (GPIO Banks)	Power to GPIO bank pins
VDDIx (HSIO Banks)	Power to HSIO bank pins
VDD25	Power to corner PLLs and PNVM
VDD18	Power to programming and HSIO auxiliary supply
VDDAUXx	Power to GPIO auxiliary supply

- $V_{REFx}$ —is the reference voltage for DDR3 and DDR4 signals. VREF voltages can be generated internally and externally.
  - Internal VREF - not subjected to PCB and package inductance and capacitance loss. These changes provide the highest performance and can be programmed as required by DDR controller.
  - External VREF— is fixed and cannot be programmed as required. The PCB and package inductance and capacitance impact the  $V_{REF}$  performance.

VDDI and VDDAUX must be tied together to the same common voltage rail when a GPIO bank requires them to be at the same voltage (2.5V or 3.3V). This prevents any voltage variations between VDDI and VDDAUX. In this case, the board must not supply the VDDI and VDDAUX from individual voltage supplies.

When a GPIO bank requires the VDDI to be less than 2.5V nominal (1.5V or 1.8V), the VDDAUX for the bank must be connected to the 2.5V nominal supply irrespective of the required VDDI supply. The VDDI requires a separate supply for the specific I/O type (1.5V or 1.8V).

**Note:** The on-chip power-on reset circuitry requires the  $V_{DD}$ ,  $V_{DD18}$ , and  $V_{DD25}$  supplies to ramp monotonically from 0 V to the minimum recommended operating voltage.

For a detailed pin description, see [UG0722: PolarFire FPGA Packaging and Pin Descriptions User Guide](#).

## 2.2.1 PolarFire Decoupling Capacitors

The following table lists the requirement of all decoupling capacitors for the MPF300-FCG1152 device.

**Table 2 • Power-Supply Decoupling Capacitors—MPF500T - FCG1152/FCG784 (1mm)**

Pin Name	Ceramic							Tantalum
	4.7 nF	10 nF	0.1 $\mu$ F	1 $\mu$ F	4.7 $\mu$ F	10 $\mu$ F	47 $\mu$ F	330 $\mu$ F
$V_{DD}$			4					3
$V_{DD18}$			2				2	
$V_{DD25}$			5			1		
$V_{DDA}$	3	1	6				2	
$V_{DDA25}$			4				1	
$V_{DDIO3}$			2			1		
$V_{DDAUXx}$ <sup>1</sup>			2				1	
GPIO Bank <sup>2</sup>			2				1	
HSIO Bank <sup>3</sup>			2				1	
VDD_XCVR_CLK			2			1		
XCVR_VREF			2					

1. Required Decoupling Capacitor for each VDDAUXx.
2. Required Decoupling Capacitor for each GPIO bank.

## 3. Required Decoupling Capacitor for each HSIO bank.

The following table lists the requirement of all decoupling capacitors for the MPF300T-FCG1152/784/484 (1 mm).

**Table 3 • Power-Supply Decoupling Capacitors—MPF300T - FCG1152/FCG784/FCG484 (1 mm)**

Pin Name	Ceramic							Tantalum
	4.7 nF	10 nF	0.1 $\mu$ F	1 $\mu$ F	4.7 $\mu$ F	10 $\mu$ F	47 $\mu$ F	330 $\mu$ F
V <sub>DD</sub>			4					2
V <sub>DD18</sub>			2				2	
V <sub>DD25</sub>			5				1	
V <sub>DDA</sub>	3	1	6				1	
V <sub>DDA25</sub>			4				1	
V <sub>DDAUXx</sub> <sup>1</sup>			5				1	
V <sub>DDIO3</sub>			2			1		
GPIO Bank <sup>2</sup>			2				1	
HSIO Bank <sup>3</sup>			2				1	
VDD_XCVR_CLK			2			1		
XCVR_VREF			2					

1. Required Decoupling Capacitor for each VDDAUXx.
2. Required Decoupling Capacitor for each GPIO bank.
3. Required Decoupling Capacitor for each HSIO bank.

The following table lists the requirement of all decoupling capacitors for the MPF300-FCVG484 (0.8mm) device.

**Table 4 • Power-Supply Decoupling Capacitors—MPF300T - FCVG484 (0.8mm)**

Pin Name	Ceramic								Tantalum
	1 nF	2.2 nF	10 nF	0.1 $\mu$ F	1 $\mu$ F	4.7 $\mu$ F	10 $\mu$ F	47 $\mu$ F	330 $\mu$ F
V <sub>DD</sub>				4	1				2
V <sub>DD18</sub>				2				2	
V <sub>DD25</sub>				5			1		
V <sub>DDA</sub>		2	2	1				1	
V <sub>DDA25</sub>	1			1				1	
V <sub>DDAUXx</sub> <sup>1</sup>				2				1	
V <sub>DDIO3</sub>				2			1		
GPIO Bank <sup>2</sup>				2				1	
HSIO Bank <sup>3</sup>				2				1	
VDD_XCVR_CLK				2			1		
XCVR_VREF				2					

1. Required Decoupling Capacitor for each VDDAUXx.
2. Required Decoupling Capacitor for each GPIO bank.
3. Required Decoupling Capacitor for each HSIO bank.

The following table lists the requirement of all decoupling capacitors for the MPF300-FCSG536 (0.5mm) device.

**Table 5 • Power-Supply Decoupling Capacitors—MPF300T - FCSG536 (0.5mm)**

Pin Name	Ceramic							Tantalum	
	1 nF	2.2 nF	10 nF	0.1 $\mu$ F	1 $\mu$ F	4.7 $\mu$ F	10 $\mu$ F	47 $\mu$ F	330 $\mu$ F
V <sub>DD</sub>				4	1				2
V <sub>DD18</sub>			1	2				2	
V <sub>DD25</sub>				5			1		
V <sub>DDA</sub>	2	3	1	1				1	
V <sub>DDA25</sub>	1			1				1	
V <sub>DDAUXx</sub> <sup>1</sup>				2				1	
V <sub>DDIO3</sub>				2			1		
GPIO Bank <sup>2</sup>				2				1	
HSIO Bank <sup>3</sup>				2				1	
VDD_XCVR_CLK				2			1		
XCVR_VREF				2					

1. Required Decoupling Capacitor for each VDDAUXx.
2. Required Decoupling Capacitor for each GPIO bank.
3. Required Decoupling Capacitor for each HSIO bank.

**Table 6 • Power-Supply Decoupling Capacitors—MPF200T - FCG784/FCG484 (1mm)**

Pin Name	Ceramic							Tantalum
	4.7 nF	10 nF	0.1 $\mu$ F	1 $\mu$ F	4.7 $\mu$ F	10 $\mu$ F	47 $\mu$ F	330 $\mu$ F
V <sub>DD</sub>		2	2					2
V <sub>DD18</sub>			2				2	
V <sub>DD25</sub>			5			1		
V <sub>DDA</sub>	3	1	6				1	
V <sub>DDA25</sub>			4				1	
V <sub>DDIO3</sub>			2			1		
V <sub>DDAUXx</sub> <sup>1</sup>			2				1	
GPIO Bank <sup>2</sup>			2				1	
HSIO Bank <sup>3</sup>			2				1	
VDD_XCVR_CLK			2			1		
XCVR_VREF			2					

1. Required Decoupling Capacitor for each VDDAUXx.
2. Required Decoupling Capacitor for each GPIO bank.
3. Required Decoupling Capacitor for each HSIO bank.

The following table lists the requirement of all decoupling capacitors for the MPF200T-FCG484 (0.8 mm) device.

**Table 7 • Power-Supply Decoupling Capacitors—MPF200T - FCG484 (0.8 mm)**

Pin Name	Ceramic									Tantalum
	1 nF	2.2 nF	4.7 nF	10 nF	0.1 $\mu$ F	1 $\mu$ F	4.7 $\mu$ F	10 $\mu$ F	47 $\mu$ F	330 $\mu$ F
V <sub>DD</sub>					4	1				2
V <sub>DD18</sub>				2					2	
V <sub>DD25</sub>					5			1		
V <sub>DDA</sub>		2		2	1				1	
V <sub>DDA25</sub>	1				1				1	
V <sub>DDIO3</sub>					2			1		
V <sub>DDAUXx</sub> <sup>1</sup>					2				1	
GPIO Bank <sup>2</sup>					2				1	
HSIO Bank <sup>3</sup>					2				1	
V <sub>DD_XCVR_CLK</sub>					2			1		
X <sub>CVR_VREF</sub>					2					

1. Required Decoupling Capacitor for each V<sub>DDAUXx</sub>.
2. Required Decoupling Capacitor for each GPIO bank.
3. Required Decoupling Capacitor for each HSIO bank.

The following table lists the requirement of all decoupling capacitors for the MPF200T-FCSG536 (0.5 mm) device.

**Table 8 • Power-Supply Decoupling Capacitors—MPF200T - FCSG536 (0.5 mm)**

Pin Name	Ceramic									Tantalum
	1 nF	2.2 nF	4.7 nF	10 nF	0.1 $\mu$ F	1 $\mu$ F	4.7 $\mu$ F	10 $\mu$ F	47 $\mu$ F	330 $\mu$ F
V <sub>DD</sub>					4	1				2
V <sub>DD18</sub>				2					2	
V <sub>DD25</sub>					5			1		
V <sub>DDA</sub>	2	3		1	1				1	
V <sub>DDA25</sub>	1				1				1	
V <sub>DDIO3</sub>					2			1		
V <sub>DDAUXx</sub> <sup>1</sup>					2				1	
GPIO Bank <sup>2</sup>					2				1	
HSIO Bank <sup>3</sup>					2				1	
V <sub>DD_XCVR_CLK</sub>					2			1		
X <sub>CVR_VREF</sub>					2					

1. Required Decoupling Capacitor for each V<sub>DDAUXx</sub>.
2. Required Decoupling Capacitor for each GPIO bank.
3. Required Decoupling Capacitor for each HSIO bank.

The following table lists the requirement of all decoupling capacitors for the MPF200T-FCG325 (0.5 mm) device.

**Table 9 • Power-Supply Decoupling Capacitors—MPF200T - FCSG325 (0.5 mm)**

Pin Name	Ceramic									Tantalum
	1 nF	2.2 nF	4.7 nF	10 nF	0.1 $\mu$ F	1 $\mu$ F	4.7 $\mu$ F	10 $\mu$ F	47 $\mu$ F	330 $\mu$ F
V <sub>DD</sub>					4	1				2
V <sub>DD18</sub>					2				2	
V <sub>DD25</sub>					5		1			
V <sub>DDA</sub>		1	1	1	1				1	
V <sub>DDA25</sub>	1				1				1	
V <sub>DDIO3</sub>					2		1			
V <sub>DDAUXx</sub> <sup>1</sup>					2				1	
GPIO Bank <sup>2</sup>					2				1	
HSIO Bank <sup>3</sup>					2				1	
V <sub>DD_XCVR_CLK</sub>					2		1			
X <sub>CVR_VREF</sub>					2					

1. Required Decoupling Capacitor for each V<sub>DDAUXx</sub>.
2. Required Decoupling Capacitor for each GPIO bank.
3. Required Decoupling Capacitor for each HSIO bank.

The following table lists the requirement of all decoupling capacitors for the MPF100T-FCSG325 (0.5 mm) device.

**Table 10 • Power-Supply Decoupling Capacitors—MPF100T - FCSG325 (0.5 mm)**

Pin Name	Ceramic									Tantalum
	1 nF	2.2 nF	4.7 nF	10 nF	0.1 $\mu$ F	1 $\mu$ F	4.7 $\mu$ F	10 $\mu$ F	47 $\mu$ F	330 $\mu$ F
V <sub>DD</sub>					4	1				1
V <sub>DD18</sub>					2				2	
V <sub>DD25</sub>					5		1			
V <sub>DDA</sub>		1	1	1	1				1	
V <sub>DDA25</sub>	1				1				1	
V <sub>DDIO3</sub>					2		1			
V <sub>DDAUXx</sub> <sup>1</sup>					2				1	
GPIO Bank <sup>2</sup>					2				1	
HSIO Bank <sup>3</sup>					2				1	
V <sub>DD_XCVR_CLK</sub>					2		1			
X <sub>CVR_VREF</sub>					2					

1. Required Decoupling Capacitor for each V<sub>DDAUXx</sub>.
2. Required Decoupling Capacitor for each GPIO bank.
3. Required Decoupling Capacitor for each HSIO bank.

The following table lists the requirement of all decoupling capacitors for the MPF100T-FCVG484 (0.8 mm) device.

**Table 11 • Power-Supply Decoupling Capacitors—MPF100T - FCG484 (0.8 mm)**

Pin Name	Ceramic									Tantalum
	1 nF	2.2 nF	4.7 nF	10 nF	0.1 $\mu$ F	1 $\mu$ F	4.7 $\mu$ F	10 $\mu$ F	47 $\mu$ F	330 $\mu$ F
V <sub>DD</sub>					4	1				1
V <sub>DD18</sub>					2				2	
V <sub>DD25</sub>					5			1		
V <sub>DDA</sub>		2		2	1				1	
V <sub>DDA25</sub>	1				1				1	
V <sub>DDIO3</sub>					2			1		
V <sub>DDAUXx</sub> <sup>1</sup>					2				1	
GPIO Bank <sup>2</sup>					2				1	
HSIO Bank <sup>3</sup>					2				1	
VDD_XCVR_CLK					2			1		
XCVR_VREF					2					

1. Required Decoupling Capacitor for each VDDAUXx.
2. Required Decoupling Capacitor for each GPIO bank.
3. Required Decoupling Capacitor for each HSIO bank.

**Table 12 • Power-Supply Decoupling Capacitors—MPF100T - FCG484 (1 mm)**

Pin Name	Ceramic							Tantalum
	4.7 nF	10 nF	0.1 $\mu$ F	1 $\mu$ F	4.7 $\mu$ F	10 $\mu$ F	47 $\mu$ F	330 $\mu$ F
V <sub>DD</sub>		2	2					1
V <sub>DD18</sub>			2				2	
V <sub>DD25</sub>			5			1		
V <sub>DDA</sub>	3	1	6				1	
V <sub>DDA25</sub>			4				1	
V <sub>DDIO3</sub>			2			1		
V <sub>DDAUXx</sub> <sup>1</sup>			2				1	
GPIO Bank <sup>2</sup>			2				1	
HSIO Bank <sup>3</sup>			2				1	
VDD_XCVR_CLK			2			1		
XCVR_VREF			2					

1. Required Decoupling Capacitor for each VDDAUXx.
2. Required Decoupling Capacitor for each GPIO bank.
3. Required Decoupling Capacitor for each HSIO bank.

Decoupling capacitors other than those listed in the previous tables can be used if the physical sizes of capacitors meet or exceed the performance of the network given in this example. Substitution would require analyzing the resulting power distribution system's impedance versus frequency to ensure that no resonant impedance spikes the result. See [Figure 1](#), page 4 for power supply design.

For more information about the internal package capacitance for power supplies associated with PolarFire packages, see section 2.4.2.1 section of *UG0722: PolarFire FPGA Packaging and Pin Descriptions User Guide*.

The following table lists the required decoupling capacitors for PolarFire packages.

**Table 13 • Recommended Decoupling Capacitors For PolarFire Devices**

De-Cap Value	Part Number	Package	Description
0.1 $\mu$ F	GRM155R71C104KA88D	0402	For 1 mm package
10 nF	GRM15XR11C103KA86	0402	For 1 mm package
4.7 nF	GRM155R11H472KA01	0402	For 1 mm package
10 $\mu$ F	GRM21BR71A106KE51	0805	Bulk Caps (for 0.5, 0.8, and 1 mm)
47 $\mu$ F	GRM31CR61A476KE15	1206	Bulk Caps (for 0.5, 0.8, and 1 mm)
330 $\mu$ F	T495D337K010ATE150	2917	Bulk Caps (for 0.5, 0.8, and 1 mm)
1 nF	GRM033R71C102KA01	0201	For 0.8/0.5 mm package
2.2 nF	GRM033R71A103KA01	0201	For 0.8/0.5 mm package
10 nF	GRM033R71A103KA01	0201	For 0.8/0.5 mm package
0.1 $\mu$ F	GRM033C71C104KE14	0201	For 0.8/0.5 mm package

**Note:** The user can use equivalent capacitor values from a different vendor. For more information about about Packaging Decoupling Capacitors, see *UG0722: PolarFire FPGA Packaging and Pin Descriptions User Guide*.

## 2.2.2 Power-Supply Topology

PolarFire FPGAs require multiple power supplies. [Figure 2](#), page 12 shows a power supply topology example for generating the required power supplies from a single 12 V source. This example is based on the PolarFire MPF300-FCG1152 device with DDR3 and DDR4 interfaces.

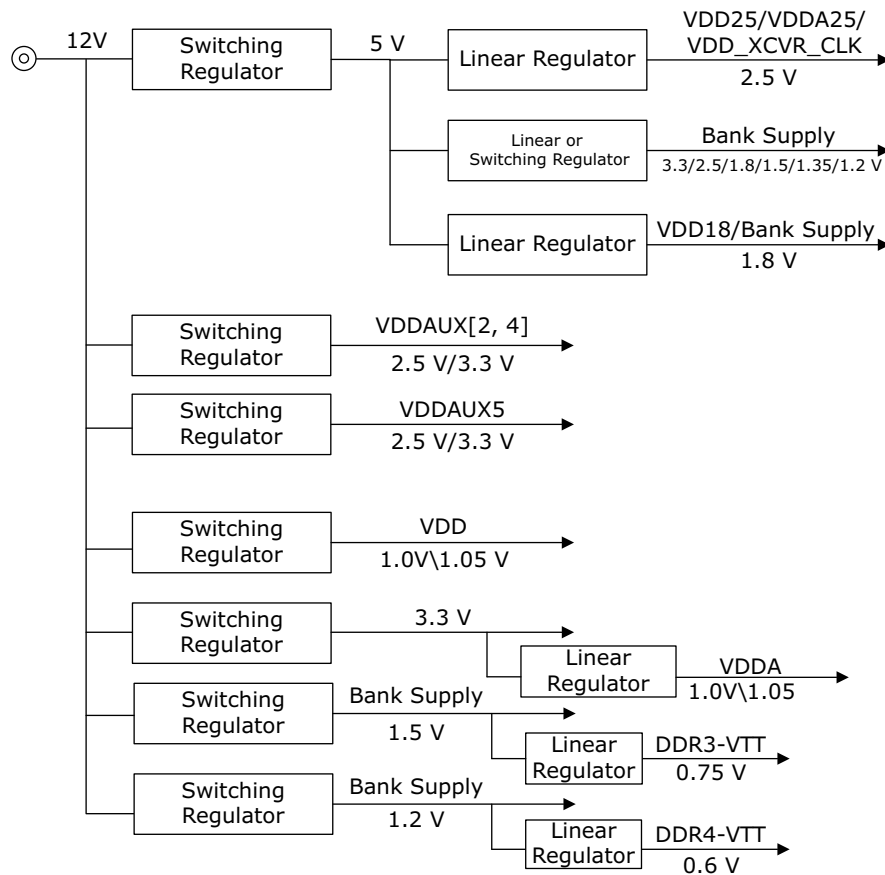

**Figure 2 • Example Power-Supply Topology**

The following table lists the suggested Microchip power regulators for PolarFire FPGA voltage rails.

**Table 14 • Power Regulators**

Voltage rail	Part Number	Description	Current
5V	MIC24055YJL-TR	IC REG BUCK ADJ 12A SYNC 28QFN	12A
VDD (1.0V)	MIC45212-2YMP-T1	DC DC CONVERTER 0.8-5.5V 77W	14A
VDDIO (3.3V)	MIC24055YJL-TR	IC REG BUCK ADJ 12A SYNC 28QFN	12A
VCCIO_HPC_VADJ	MIC24046YFL-TR	IC REG BUCK PROG 5A SYNC 20VQFN	5A
DDR4 (1.2V)	MIC23303YML-T5	IC REG BUCK ADJ 3A SYNC 12DFN	3A
DDR3 (1.5V)	MIC23303YML-T5	IC REG BUCK ADJ 3A SYNC 12DFN	3A
VDDAUX[2,4]	MIC23303YML-T5	IC REG BUCK ADJ 3A SYNC 12DFN	3A
VDDAUX5	MIC23303YML-T5	IC REG BUCK ADJ 3A SYNC 12DFN	3A
VTT_DDR4 (0.6V)	MIC5166YML-TR	IC PWR SUP 3A HS DDR TERM 10MLF	3A
VTT_DDR3 (0.75V)	MIC5166YML-TR	IC PWR SUP 3A HS DDR TERM 10MLF	3A
VDDIO (1.8V)	MIC24046YFL-TR	IC REG BUCK PROG 5A SYNC 20VQFN	5A
VDDA (1.0V)	MIC69502WR	IC REG LINEAR POS ADJ 5A SPAK-7	5A
VDD25, VDDA25, VDD_XCVR_CLK	MIC69502WR	IC REG LINEAR POS ADJ 5A SPAK-7	5A

**Table 14 • Power Regulators (continued)**

Voltage rail	Part Number	Description	Current
VDD18	MIC69502WR	IC REG LINEAR POS ADJ 5A SPAK-7	5A

### 2.2.3 Unused Power Supply

The following figures shows the recommended unused connections for power supplies and I/O banks.

**Figure 3 • Option 1 for Unused Connections**

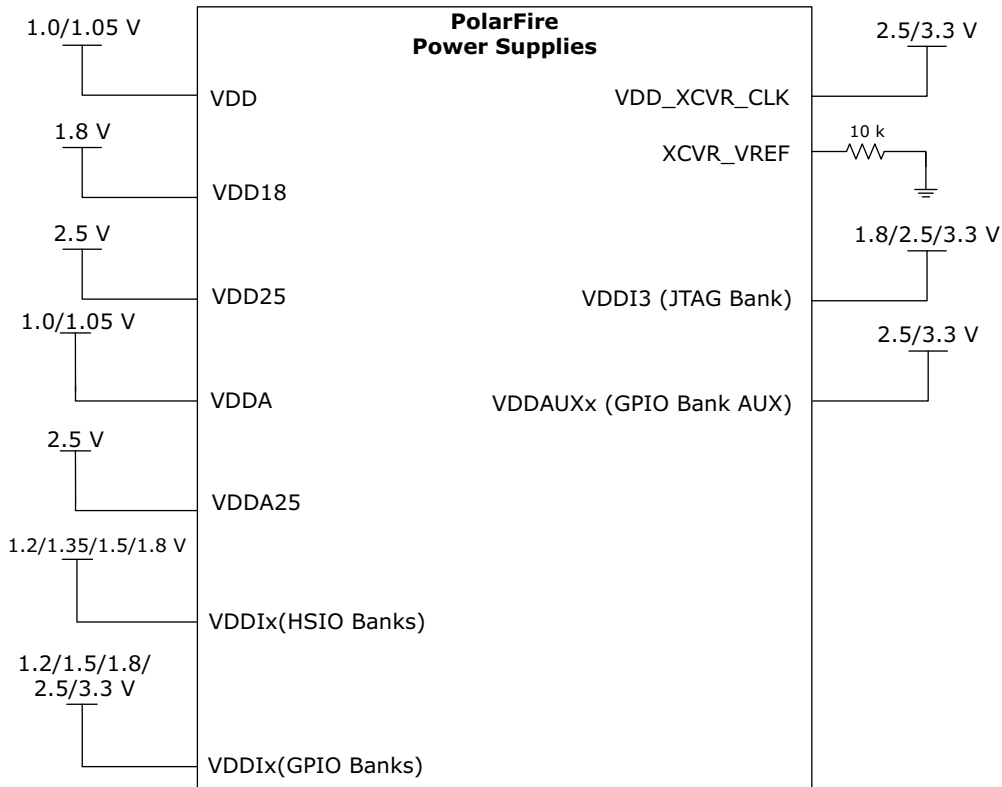

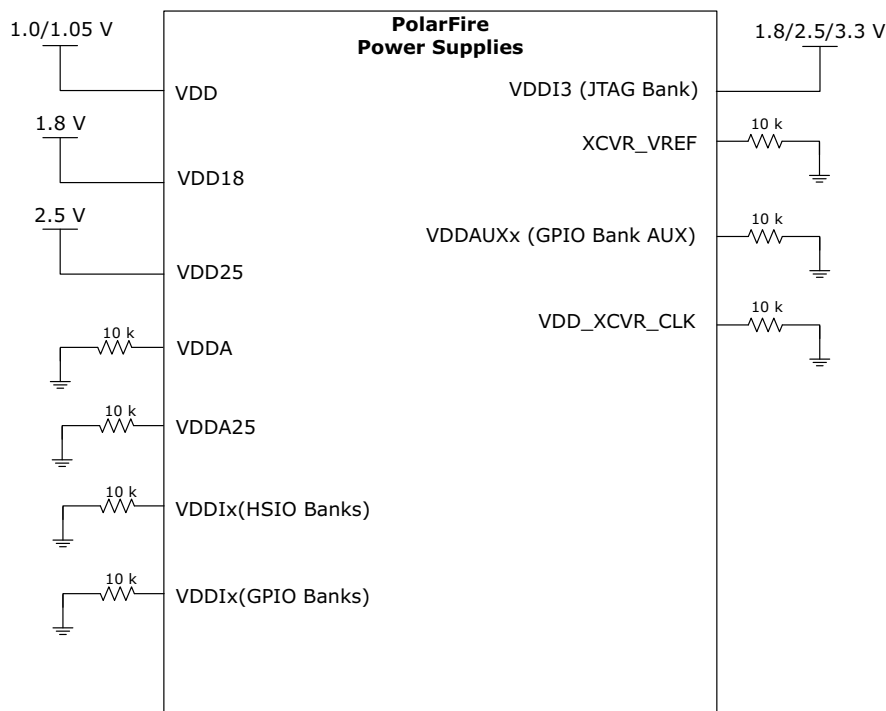
**Figure 4 • Option 2 for Unused Connections**

**Note:** To simplify the board-level routing, multiple 10 kΩ resistors can be used as required. Or the power supplies can also be grouped into a single 10 kΩ resistor and tied-off to VSS.

## 2.2.4 Pin Assignment Tables

The Packaging Pin Assignment Table (PPAT) is available on the Microsemi PolarFire documentation web page (<https://www.microsemi.com/products/fpga-soc/fpga/polarfire-fpga#documentation>). PPAT contains information about the recommended DDR pin-outs, PCI EXPRESS capability for XCVR-0, DDR Lane information for IO CDR, generic IOD interface pin placement, and unused condition for package pins.

## 2.3 I/O Glitch

For GPIO/HSIO outputs, PolarFire devices may undergo a glitch at power-up. The glitch may occur before or after the device reaches a functional state. For GPIOs, a maximum glitch of 1V with a 0.8 ms width, whereas a maximum glitch of 0.5V with a 0.4 ms width may be seen for HSIOs. In either cases, the device is not affected with any reliability issues.

The glitch is caused by a short-term capacitive charging and does not cause any issues in user designs if the system includes a robust reset design that ignores any glitches that inadvertently occur at power-up.

The glitch cannot be ignored in the user design, it can be mitigated if the user follows this power-up sequence of bringing up:

- VDDIO, VDD (Core), and VDDAUX (Auxiliary for GPIO)/VDD18 (Programming and Aux supply for HSIO) respectively.
- The following power-up sequences are not recommended because the glitch cannot be removed using an external 100K pull-down resistor:
  - VDD (Core), VDDIO(GPIO), VDDAUX(GPIO-Auxiliary)
  - VDDIO (GPIO), VDDAUX (GPIO-Auxiliary), VDD (Core)

For power-up sequences other than the above-mentioned, a 100K pull-down resistor can be used to mitigate the glitch at each output I/O. This is needed only for critical output nets like resets and clocks. This usage avoids any trigger or event on another device on the clock or reset signals. The resistor can be of any size and tolerance with a minimum voltage of 6V and a minimum power rating of 0.1W.

## 2.4 User I/O

PolarFire FPGAs have two types of I/O buffers: HSIO and GPIO. HSIO buffers are optimized for single-ended buffers with supplies from 1.2 V to 1.8 V. GPIO buffers support single-ended and true differential interfaces with supplies from 1.2 V to 3.3 V.

**Note:** When the HSIO bank is configured as an LVDS receiver, the concerned I/Os must be connected externally by a 100  $\Omega$  resistor.

For more information about key features of I/O buffers and supported standards, see [UG0722: PolarFire FPGA Packaging and Pin Descriptions User Guide](#) and [UG0686: PolarFire FPGA User I/O User Guide](#).

### 2.4.1 Cold Sparing

PolarFire devices support cold sparing for GPIO and HSIO. Cold sparing is implemented by connecting the devices as shown in the following figure. The system board has two PolarFire devices in parallel and the devices share I/O. The spare device has its HSIO VDDI banks powered-up to prevent I/O leakage through the ESD diodes. As a result, low power and a protected state for the spare device is established. The spare device can be changed to active device by powering-up all the supplies. The active device can be changed to spare device by powering down all the supplies except HSIO VDDI banks.

A typical cold sparing application integrates two parallel devices with shared I/O connections, as shown in the following figure.

**Figure 5 • Cold Sparing**

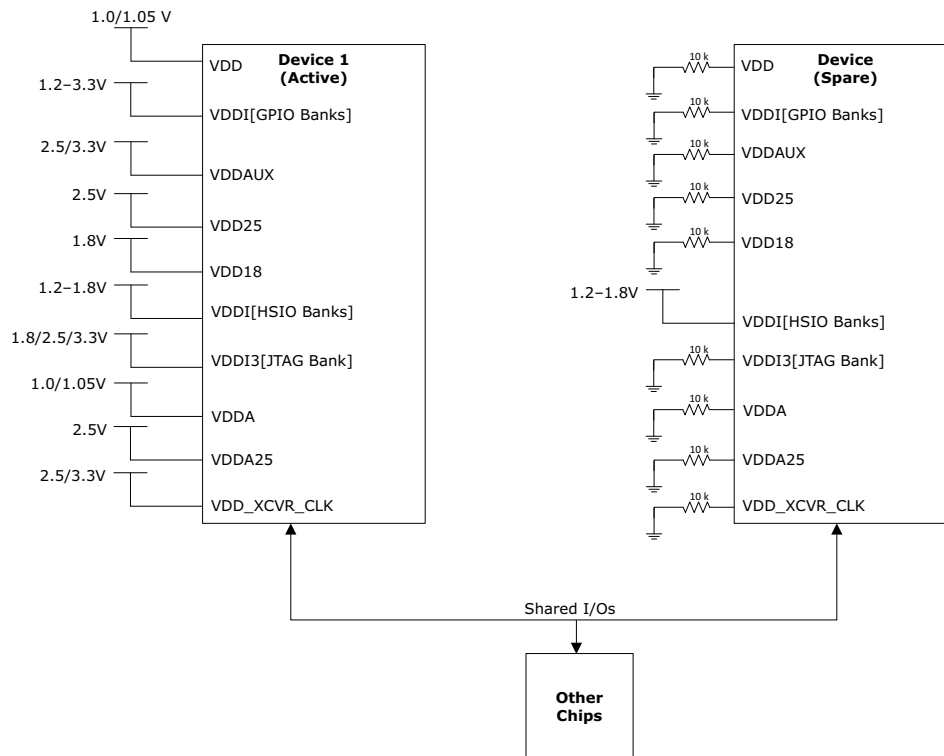

**Note:** Transceiver and JTAG pins do not support the cold sparing feature.

### 2.4.2 Hot Socketing (GPIO Only)

Hot socketing (also known as hot swapping or hot plug-in) prevents damage to the PolarFire FPGA if, at any time, voltage is detected at I/O while the device is powered off. It also helps prevent disruptions that may occur in the rest of the system if the I/O of a device are connected without a valid power supply.

Only GPIOs support hot socketing. In hot socketing, GPIOs are in high-impedance (hi-Z) state.

The GPIO maintains the following high-impedance state until the power supplies are at a valid state.

- $V_{DDAUx}$  is greater than or equal to 1.6 V
- $V_{DDIx}$  is greater than or equal to 0.8 V
- $V_{DD}$  and  $V_{DD25}$  are both high and the PolarFire FPGA controller has asserted the global I/O ring signal (IO\_EN)

### 2.4.2.1 Over-Voltage Tolerance for GPIO

If GPIO is configured with the following settings, GPIO supports over-voltage tolerance, ensuring that the I/O signal at the pad is at a higher potential than the  $V_{DDIx}$  power supply.

**Table 15 • Over-Voltage Tolerance**

Standard	OE	Clamp Diode	$V_{REF}$ (Input)	Weak Pull-Up/ Pull-Down	Termination	Hot-plug
PCI	x	On	On	On	On	Disabled
GPIO	1	On	On	On	On	Disabled
	0	Off	Off	Off	Off	Enabled

For recommended operating conditions about over-voltage tolerance, see [DS0141: PolarFire FPGA Datasheet](#).

## 2.5 Clocks

PolarFire devices offer two on-chip RC oscillators (one 2 MHz and one 160 MHz) to generate free-running clocks. The clocks do not have any I/O pads and do not require external components to operate.

The following table lists the number of RC oscillators available in PolarFire devices.

**Table 16 • RC Oscillator Count**

Resource	Supported Range (MHz)	MPF100	MPF200	MPF300	MPF500
On-chip oscillator	2	1	1	1	1
	160	1	1	1	1

For more information about clocking in PolarFire devices, see [UG0684: PolarFire FPGA Clocking Resources User Guide](#).

## 2.6 Reset

For designing a robust system users may use the dedicated DEVRST\_N pin or a general purpose reset signal using any GPIO/HSIO as a global system level reset.

For the following cases the users must use the DEVRST\_N as a warm reset for the device:

- A user design modifies auto-initialized fabric RAMs or PCIe configuration during operation.
- A user design is using PCIe, transceivers or user crypto.

For all other use cases, it is recommended to use a general purpose reset signal using any GPIO/HSIO IO because they take much shorter time for design to come out of reset.

If the dedicated DEVRST\_N is not used for warm resets, the DEVRST\_N pin must be configured using one of the following methods:

- Drive the signal with a POR chip or an external device and keep the DEVRST\_N asserted till the system/clocks are stable and the chip is properly powered up.
- Connect DEVRST\_N to VDDI3 through a 1 k $\Omega$  resistor per pin without sharing with any other pins.

- In this case the user needs to ensure that all clocks are stable going to the device before the user design is released from power-on reset. The details of the minimum time taken for the fabric design to be activated after power-on is specified in the PolarFire datasheet (Power-Up To Functional section).

## 2.7 DDR

PolarFire devices support DDR3, DDR3L, LPDDR3, and DDR4. For more information about the DDR support in PolarFire devices, see [DS0141: PolarFire FPGA Datasheet](#).

The reliability of the DDR interface depends on the quality of the layout. For detailed information on board layout and routing, see [UG0676: PolarFire FPGA DDR Memory Controller User Guide](#).

## 2.8 Device Programming

The PolarFire device can be programmed using one of two dedicated interfaces: JTAG or SPI. These two interfaces support the following programming modes:

- JTAG programming
- SPI master mode programming
- SPI slave mode programming

The PolarFire FPGA supports programming modes through the internal system controller using SPI master mode, or an external master using JTAG or SPI interfaces. For detailed information on hardware connections for each programming mode, see [UG0714: PolarFire FPGA Programming User Guide](#).

### 2.8.1 JTAG Programming

The JTAG interface is used for device programming and testing, or for debugging firmware. When the device reset (DEV\_RST\_N) is asserted, JTAG I/Os are not accessible. JTAG I/Os are powered by Bank 3  $V_{DDI3}$ .

The following illustration shows the board-level connectivity for JTAG programming mode in PolarFire devices.

**Figure 6 • JTAG Programming**

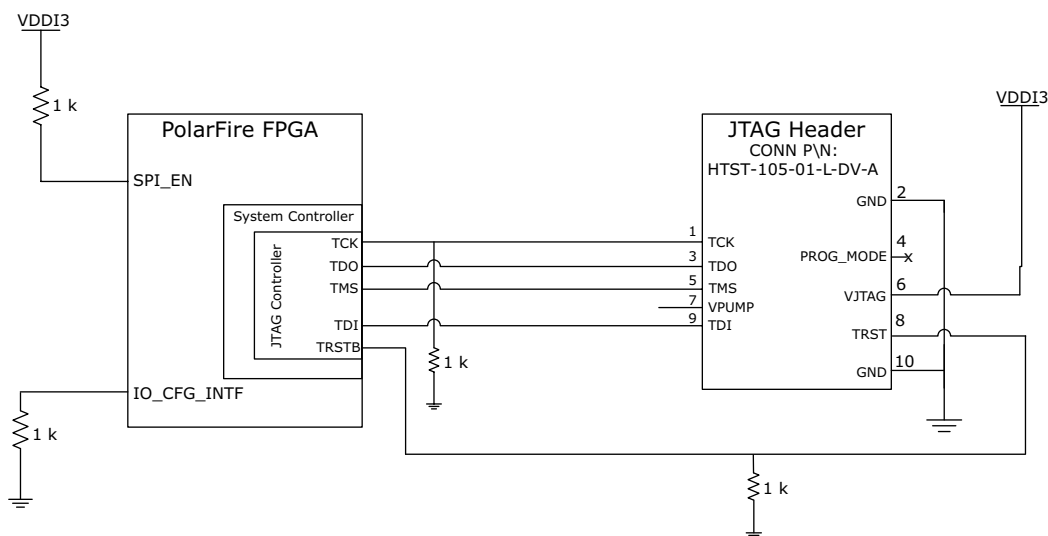

The following table lists the JTAG pin names and descriptions.

**Table 17 • JTAG Pins**

Pin Names	Direction	Unused Condition	Description
TMS	Input	DNC	JTAG test mode select.
TRSTB	Input	Must be connected to $V_{DDI3}$ through a 1 k $\Omega$ resistor	JTAG test reset. Must be held low during device operation.

**Table 17 • JTAG Pins (continued)**

Pin Names	Direction	Unused Condition	Description
TDI	Input	DNC	JTAG test data in.
TCK	Input	Must be connected to VSS through a 10 kΩ resistor	JTAG test clock.
TDO	Output	DNC	JTAG test data out.

## 2.8.2 SPI Master Mode Programming

The embedded system controller contains a dedicated SPI block for programming, which can operate in master or slave mode. In master mode, the PolarFire device interfaces are used to download programming data through the external SPI flash. In slave mode, the SPI block communicates with a remote device that initiates download of programming data to the device.

The following illustration shows the board-level connectivity for SPI master mode programming in PolarFire devices.

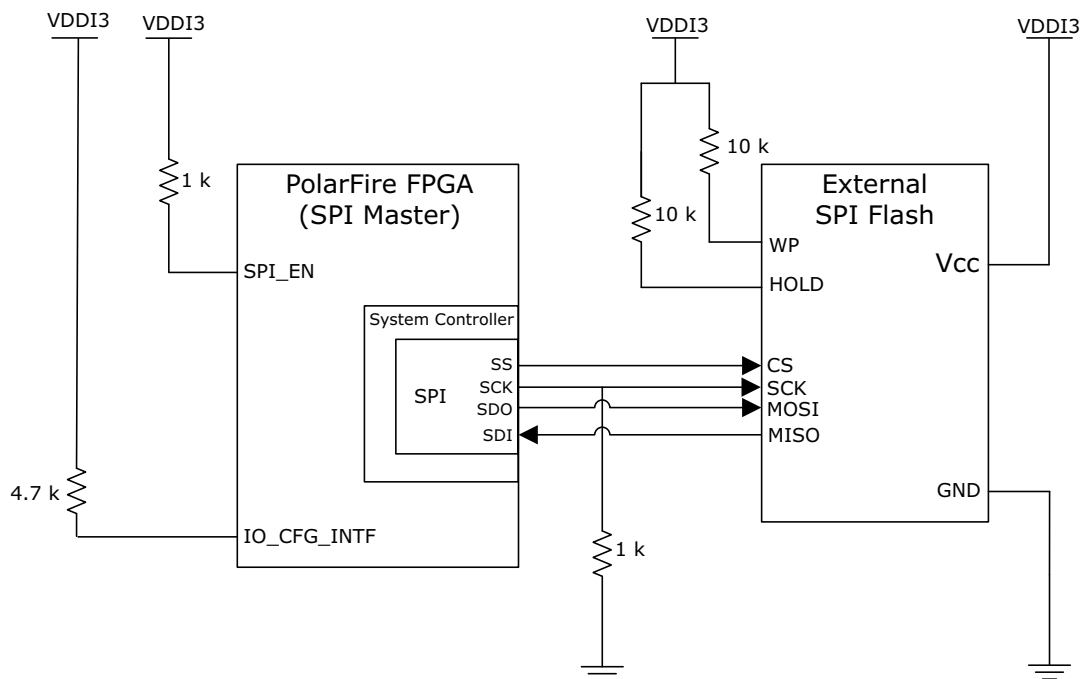
**Figure 7 • SPI Master Mode Programming**

The following table lists the SPI master mode programming pins.

**Table 18 • SPI Master Mode Programming Pins**

SPI Pin Name	Direction	Unused Condition	Description
SCK	Bidirectional	Connect to VSS through a 10 kΩ resistor	SPI clock. <sup>1</sup>
SS	Bidirectional	Connect to VSS through a 10 kΩ resistor	SPI slave select. <sup>1</sup>



**Table 18 • SPI Master Mode Programming Pins (continued)**

SPI Pin Name	Direction	Unused Condition	Description
SDI	Input	Connect to V <sub>DDI3</sub> through a 10 k $\Omega$ resistor	SDI input. <sup>1</sup>
SDO	Output	DNC	SDO output. <sup>1</sup>
SPI_EN	Input	Connect to VSS through a 10 k $\Omega$ resistor	SPI enable. 0: SPI output tri-stated 1: Enabled Pulled up or down through a resistor or driven dynamically from an external source to enable or tri-state the SPI I/O.
IO_CFG_INTF	Input	Connect to VSS through a 10 k $\Omega$ resistor	SPI I/O configuration. 0: SPI slave interface 1: SPI master interface Pulled up or down through a resistor or driven dynamically from an external source to indicate whether the shared SPI is a master or slave.

1. The SCK, SS, SDI, and SDO pins are shared between the system controller and the FPGA fabric. When the system controller's SPI is enabled and configured as a master, the system controller hands over the control of the SPI to the fabric (after device power-up).

### 2.8.3 SPI Slave Mode Programming

The following illustration shows the board-level connectivity for SPI slave mode programming in PolarFire devices.

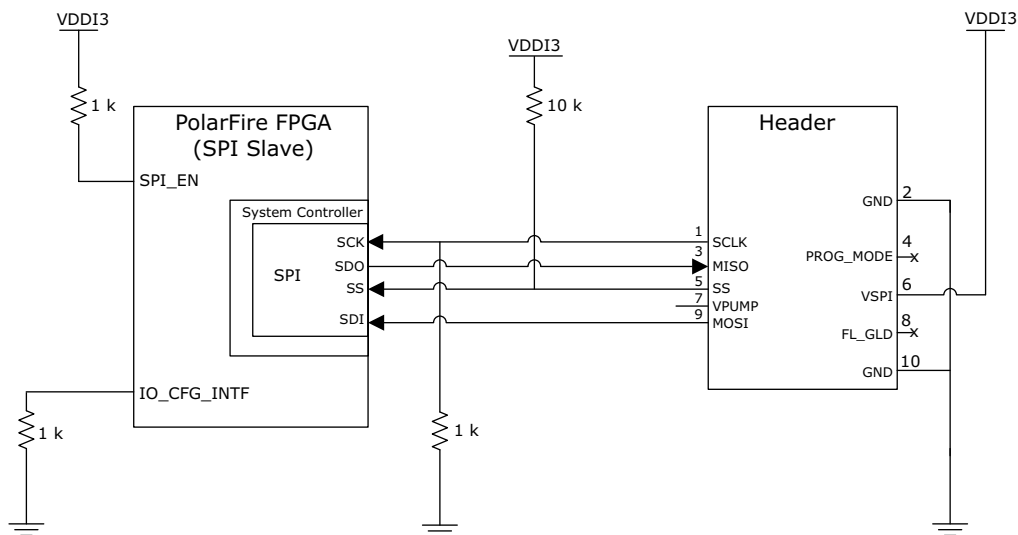
**Figure 8 • SPI Slave Mode Programming**

### 2.8.4 Special Pins

For information about special pins, see Table 13 of *UG0722: PolarFire FPGA Packaging and Pin Descriptions User Guide*.

## 2.9 Transceiver

The following table lists the transceiver features supported in PolarFire devices, and transceiver blocks are located on the east corner of the device. PolarFire devices support PCIe interface supports only Transceiver quad 0.

For more information about implementing PCIe interfaces, see [UG0685: PolarFire FPGA PCI Express User Guide](#). For more information about implementing other transceiver based interfaces and power supplies, see [UG0677: PolarFire FPGA Transceiver User Guide](#).

The following table lists the number of transceivers supported in various PolarFire devices.

**Table 19 • Transceiver Support in PolarFire Devices**

Device	Transceiver Lane	Tx PLL	Reference Clock I/O
MPF100	8	6	12
MPF200	16	11	22
MPF300	16	11	22
MPF500	24	15	30

For more information about supported I/O standards, see [UG0686: PolarFire FPGA User I/O User Guide](#).

### 2.9.1 Reference Clock

A transceiver reference clock is delivered to each transmit PLL for transmit functions and to each receiver lane for receive clock data recovery (CDR).

#### 2.9.1.1 Transceiver Reference Clock Requirements

The following are requirements for the transceiver reference clock:

- When differential clock input is provided to the reference clock:
  - ODT must be enabled for transceiver reference clock pins.
  - Must be within the range of 20 MHz to 400 MHz.
- Must be within the tolerance range of I/O standards. The reference input buffer is provided and is expected to support these input standards directly without external components on the board. The reference I/O standards such as LVCMOS25, SSTL18, LVDS25, and HCSL25 are supported. For more information, see [UG0677: PolarFire FPGA Transceiver User Guide](#).

See the *PCI Express Base specification Rev 2.1* for detailed PHY specifications. Also, see the *PCIe Add-in Card Electro-Mechanical (CEM)* specifications.

## 2.10 MIPI Hardware Design Guidelines

The following sections discuss the guidelines for MIPI RX and TX interface with PolarFire device.

### 2.10.1 MIPI RX

The MIPI RX is supported only in GPIO Bank. The corresponding Bank voltage (VDDI), and VDDAUX voltage must be connected as shown in the following figure.

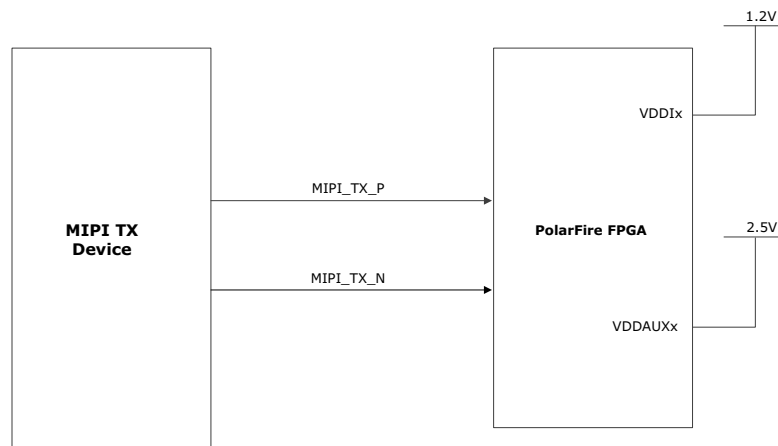
**Figure 9 • MIPI RX Connection**

MIPI RX signal connections are as follows:

- Four data and clock must be within one DDR\_Lane.
- Connect the data signals to adjacent DDR\_Lanes, if more than four data signals are available.
- The MIPI RX clock must be connected to a CLKIN pin.

For more information about DDR\_Lane, see the package pin assignment tables available at <https://www.microsemi.com/product-directory/fpgas/3854-polarfire-fpgas#documentation>.

## 2.10.2 MIPI TX

The MIPI LP (Low Power) signals should be connected to a 1.2 V GPIO\HSIO Bank supply and High-speed signals should be connected to a 2.5 V GPIO Bank supply. Select the HS and LP pins in adjacent pins to minimize the LP stub. The HS data and clock signals should be in one DDR\_Lane. For more information about DDR\_Lane information, see the package pin assignment tables available at <https://www.microsemi.com/product-directory/fpgas/3854-polarfire-fpgas#documentation>.

The MIPI TX standard can be implemented by using the resistor divider network for LP (Low Power) and HS (High speed) signals, as shown in the following figure. The resistor values mentioned in the following provide a throughput upto of 1 Gbps.

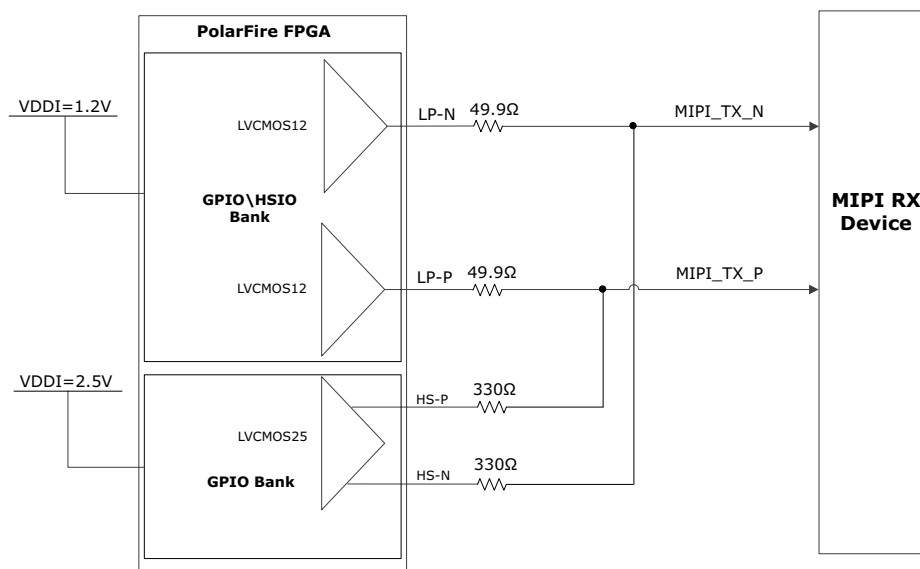
**Figure 10 • MIPI TX Connections**

**Note:** Run the PDC verification in the Libero tool before moving to layout. To know about MIPI RX electrical characteristics, refer the [DS0141: PolarFire FPGA Datasheet](#).

For information about the MIPI layout guidelines, see [MIPI](#), page 28.

## 2.11 AC and DC Coupling

Each transmit channel of a PCIe lane must be AC-coupled to allow link detection. Capacitors used for AC coupling must be external to the device and large enough to avoid excessive low-frequency drops when the data signal contains a long string of consecutive identical bits. For non-PCIe applications, Microsemi recommends that a PolarFire device receives inputs that are AC-coupled to prevent common-mode mismatches between devices. Suitable values (for example, 0.1  $\mu\text{F}$ ) for AC-coupling capacitors must be used to maximize link signal quality and must conform to [DS0141: PolarFire FPGA Datasheet](#) electrical specifications.

For lower data rates as per the data sheet, DC coupling is supported by PolarFire Transceiver Tx and Rx interfaces through a configuration option. If a PolarFire transmitter is used to drive a PolarFire receiver in DC-coupled mode, select the lowest common mode setting for the transmitter.

## 2.12 Brownout Detection

The PolarFire FPGA functionality is guaranteed only if  $V_{DD}$  is above the recommended level specified in the Datasheet. Brownout detection occurs when  $V_{DD}$  drops below the minimum recommended operating voltage. When this occurs, the device operation may not be reliable. The design might continue to malfunction even after the supply is brought back to the recommended values because parts of the device might have lost functionality during brownout. The  $V_{DD}$  supply is protected by an built-in brownout detection circuit.

## 3 Board Design Checklist

This chapter provides a set of hardware board design checks for designing hardware using Microsemi PolarFire FPGAs. The checklists provided in this chapter are a high-level summary checklist to assist the design engineers in the design process.

### 3.1 Prerequisites

Ensure that you have gone through the following chapters before reading this chapter:

- [PolarFire FPGA Board Design](#), page 3
- [Appendix: General Layout Design Practices](#), page 28

This checklist is intended as a guideline only. The PolarFire family consists of FPGAs ranging from densities of 100 K to 500 K logic elements (LEs).

### 3.2 Design Checklist

The following table lists the various checks that design engineers must take care while designing the system.

**Table 20 • Design Checklist**

Guideline	Yes/No	Remarks
<b>Prerequisites</b>		
– See <a href="#">DS0141: PolarFire FPGA Datasheet</a>		
– See <a href="#">UG0722: PolarFire FPGA Packaging and Pin Descriptions User Guide</a>		
Refer to the board-level schematics of PolarFire Evaluation Kit		
<b>Device Selection</b>		
Check for available device variants for PolarFire FPGA		
– Select a device based on I/O pin count, transceivers, package, phase-locked loops (PLLs), and speed grade		
Check device errata in PolarFire FPGA Errata		
<b>Design Checklist</b>		
<b>Power Analysis</b>		
Download the <a href="#">PolarFire Power Estimator</a> and check for the power budget.		
<b>Power Supply Checklist</b>		
See <a href="#">Figure 1</a> , page 4 for used power rails, and <a href="#">Figure 3</a> , page 13 and <a href="#">Figure 4</a> , page 14 for unused rails.		
<b>Decoupling Capacitors</b>		
Follow <a href="#">PolarFire Decoupling Capacitors</a> , page 5. Perform PI Analysis for any deviation from the recommended capacitors.		
<b>Clocks</b>		
For more information about dynamic phase shift ports, see Table 6 of <a href="#">UG0684: PolarFire FPGA Clocking Resources User Guide</a> . The XCVR reference clock ranges from 20 MHz to 400 MHz.		

**Table 20 • Design Checklist (continued)**

Guideline	Yes/No	Remarks
<p>The global clock network can be driven by any of the following:</p> <ul style="list-style-type: none"> <li>– Preferred clock inputs (CLKIN_z_w)</li> <li>– On-chip oscillators</li> <li>– CCC (PLL/DLL)</li> <li>– XCVR interface clocks</li> </ul>		
<p><b>High-Speed I/O Clocks</b></p>		
<p>High-speed I/O clock networks can be driven by I/O or CCCs. The high-speed I/O clocks can feed reference clock inputs of adjacent CCCs through hardwired connections.</p>		
<p><b>CCC</b></p>		
<p>The CCC can be configured to have a PLL or DLL clock output, driving a high-speed I/O clock network.</p>		
<p>Global buffer (GB) can be driven through the dedicated global I/O, CCC or fabric (regular I/O) routing. The global network is composed of GBs to distribute low-skew clock signals or high-fanout nets. Dedicated global I/O drive the GBs directly and are the primary source for connecting external clock inputs (to minimize the delay) to the internal global clock network. For more information about global clock network, see <a href="#">UG0684: PolarFire FPGA Clocking Resources User Guide</a>.</p>		

**Table 20 • Design Checklist (continued)**

Guideline	Yes/No	Remarks
<b>Reset</b>		
For more information about DEVRST_N and user reset, see <a href="#">Reset</a> , page 16.		
<b>DDR Interface</b>		
For more information about DDR routing and topology, see <a href="#">UG0676: PolarFire FPGA DDR Memory Controller User Guide</a> .		
<b>Programming and Debugging Scheme</b>		
For programming and debugging information, see <a href="#">Device Programming</a> , page 18.		
<b>XCVR</b>		
For more information about XCVR, see <a href="#">UG0677: PolarFire FPGA Transceiver User Guide</a> .		
For I/O gearing interfaces, place the clocks and data based on the defined requirements by selecting the correct I/O. For more information about the placement of User I/O, see <a href="#">UG0686: PolarFire FPGA User I/O User Guide</a> .		
There is one IO_CFG_INTF pin available, which can be used as input.		
See the bank location diagrams in the <a href="#">UG0722: PolarFire FPGA Packaging and Pin Descriptions User Guide</a> to assess the preliminary placement of major components on PCB.		

### 3.3 Layout Checklist

The following table lists the layout checklist.

**Table 21 • Layout Checklist**

Guideline	Yes/No
<b>Power</b>	
Are the 0402 or lesser size capacitors used for all decapacitors?	
Is the required copper shape provided to core voltage?	
Are the required copper shape and sufficient vias provided to voltages?	
Are VREF planes for the DDRx reference supply isolated from the noisy planes?	
Are sufficient number of decoupling capacitors used for the DDRx core and VTT supply?	
Is one 0.1 $\mu$ F capacitor for two VTT termination resistors used for DDRx?	
Is the VTT plane width sufficient?	
<b>DDR Memories</b>	
Are the length-match recommended by Micron followed for DDR memories?	
<b>XCVR</b>	
Are the length-match recommendations for XCVR followed?	
Are DC blocking capacitors required for PCIe interface?	
Is tight-controlled impedance maintained along the XCVR traces?	
Are differential vias well designed to match XCVR trace impedance?	
Are DC blocking capacitor pads designed to match XCVR trace impedance?	

**Table 21 • Layout Checklist (continued)**

<b>Guideline</b>	<b>Yes/No</b>
<b>Dielectric Material</b>	
Is proper PCB material selected for critical layers?	



## 4 Appendix: General Layout Design Practices

This chapter provides guidelines for the hardware board layout that incorporates PolarFire devices. Good board layout practices are essential to achieve the expected performance from PCBs and PolarFire devices. They help achieve high-quality and reliable results such as low-noise levels, signal integrity, impedance, and power requirements. The guidelines mentioned in this document act as a supplement to the standard board-level layout practices.

This chapter is intended for readers who are familiar with the PolarFire FPGA chip, experience in digital board layout, and know about line theory and signal integrity.

### 4.1 MIPI

#### MIPI RX Layout Guidelines:

The data and clock must be matched within 20 mils in PCB.

#### MIPI TX Layout Guidelines:

As shown in [Figure 11](#), page 28, the LP and HS resistors must be close to the PolarFire device pin. The HS signals should be routed to LP resistors to minimize the LP signals PCB stub length. The LP signals stub should be less than 500 mils. The data lane and clock should be length matched within 20 mils. 8 inches is the maximum length supported.

**Figure 11 • MIPI TX Layout**

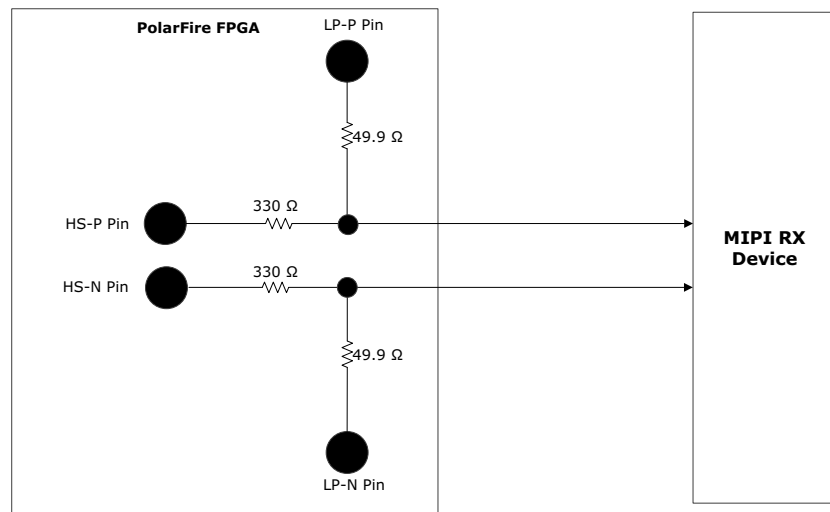

## 4.2 Transceiver

Collateral material of the PolarFire FPGA transceiver enables the system implementation easier for the designer by providing the system solution. Transceivers are high-speed serial connectivity with built-in, multi-gigabit, multi-protocol transceivers from 250 Mbps to 12.7 Gbps. For these transceiver-based interfaces, the system designer must be familiar with the industry specifications, transceivers technology, or RF/microwave PCB design. However, the PCB design can be evaluated by a knowledgeable high-speed digital PCB designer.

### 4.2.1 Layout Considerations

This section describes differential traces and skew matching, which must be taken care while designing the PCB layout.

#### 4.2.1.1 Differential Traces

A well-designed differential trace must have the following qualities:

- No Mismatch in impedance
- Insertion loss and return loss
- Skew within the differential traces

The following points must be considered while routing the high-speed differential traces to meet the previous qualities.

- The traces should be routed with tight length matching (skew) within differential traces. Asymmetry in length causes conversion of differential signals in Common mode signals.
- The differential pair should be routed such that the skew within differential pairs is less than 5 mils. The length match should be used by matching techniques.

#### 4.2.1.2 Skew Matching

The length of differential lanes should be matched within the TX and RX group. This applies only to specific protocols such as XAUI.

Differential pairs should be routed symmetrically in-to and out of structures, as shown in Figure 13, page 29.

The following figure shows the skew matching.

Figure 12 • Skew Matching

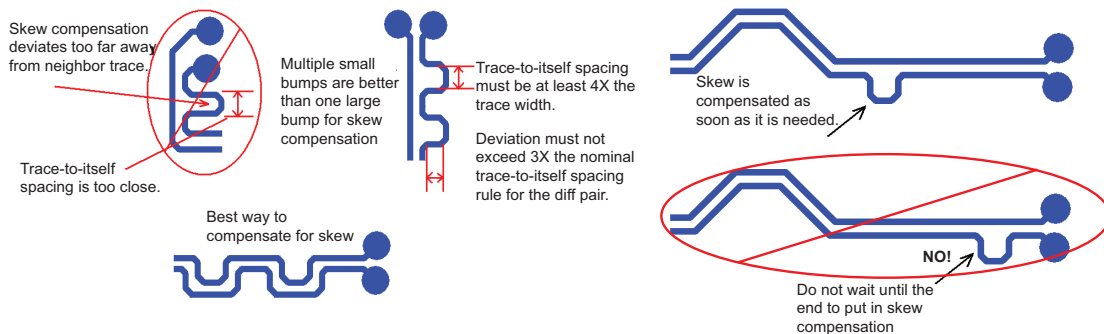

Figure 13 • Example of Asymmetric and Symmetric Differential Pairs Structure



Skin effect dominates as the speed increases. To reduce the skin effect, the width of the trace must be increased (loosely coupled differential traces). Increase in trace width causes increase in dielectric losses. To minimize dielectric loss, use low dissipation factor (DF) PCB materials such as Nelco 4000-13EP SI. Cost is significantly higher than FR4 PCB material, but FR4 PCB material cannot provide increased eye-opening when longer trace interconnections are required. Ensure that a 85 - 100  $\Omega$  differential impedance is maintained. This is an important guideline to be followed if the data rate is 5 Gbps or higher.

Far end crosstalk is eliminated by using stripline routing. However, this type of routing in stripline causes more dielectric loss. In order to minimize dielectric loss, it is better to route as a microstrip if there is enough space between differential pairs (>4 times the width of the conductor). Simulations are recommended to see the best possible routing.

Instruct the fabrication vendor to use these PCB materials before manufacturing.

Transceiver traces must be kept away from the aggressive nets or clock traces. For example, on MPF300 devices, the transceiver and DDR traces should not be adjacent to each other. Trace stubs must be avoided.

It is recommended to use low roughness, that is, smooth copper. As the speed increases, insertion loss due to the copper roughness increases. The attenuation due to skin effect is increased proportional to the square root of frequency. Microsemi recommends instructing the PCB fabrication house to use smooth copper, if the frequency exceeds 2 Gbps.

Split reference planes should be avoided. Ground planes must be used for reference for all transceiver lanes.

**Figure 14 • Ground Planes for Reference**

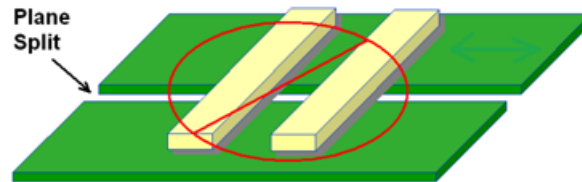

#### 4.2.1.3 Via

The target impedance of vias are designed by adjusting the pad clearance (anti-pad size). Field solver should be used to optimize the via according to the stack-up.

**Figure 15 • Via Illustration**

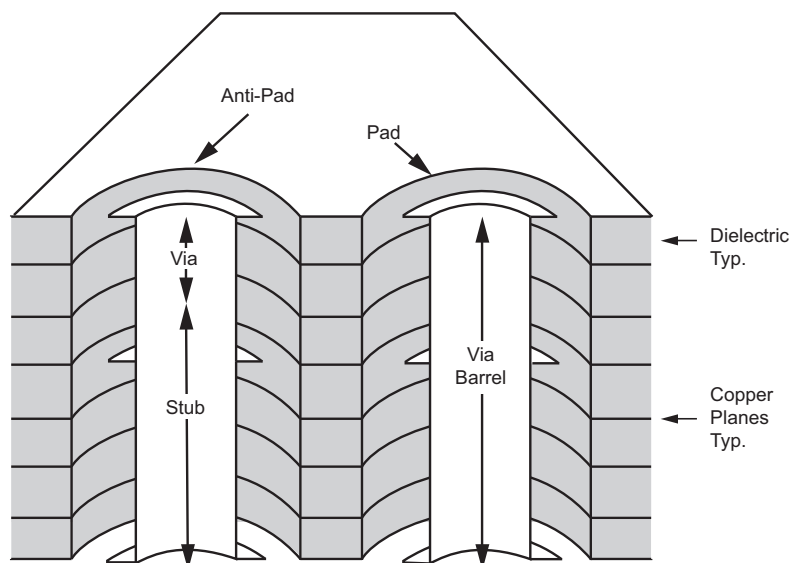

- Many vias on different traces should be avoided, or minimized as much as possible.
- The length of via stubs should be minimized by back-drilling the vias, routing signals from the near-top to the near-bottom layer, or using blind or buried vias. Using blind-vias and back drilling are good methods to eliminate via stubs and reduce reflections.
- If feasible, non-functional pads should be removed. Non-functional pads on-via are the pads where no trace is connected. This reduces the via capacitance and stub effect of pads.

**Figure 16 • Non-Functional Pads of Via**

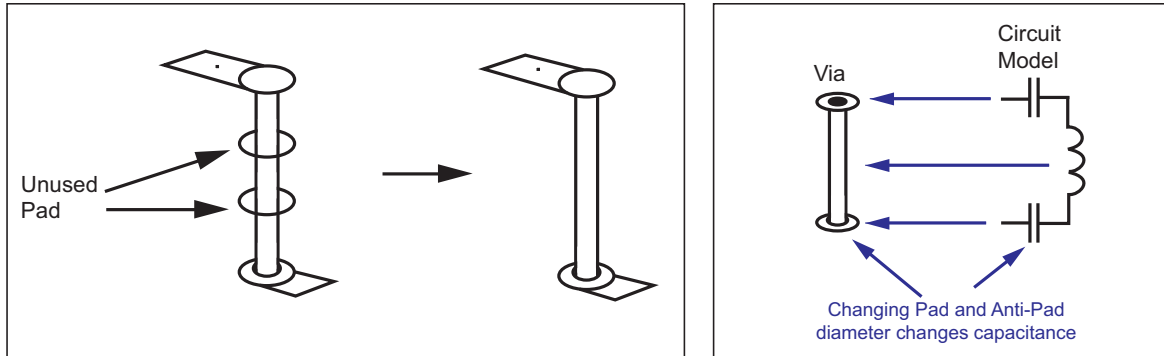

Using tight via-to-via pitches helps reducing the effect of crosstalk, as shown in the following figure.

**Figure 17 • Via-to-Via Pitch**

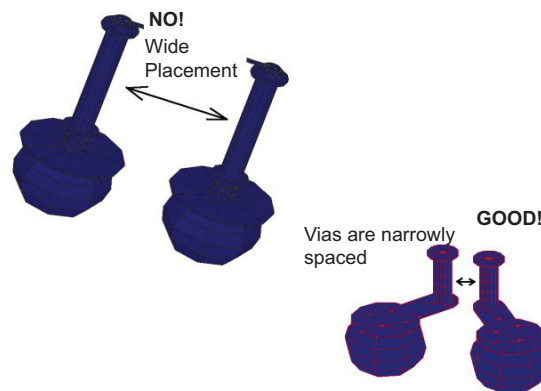

Symmetrical ground vias (return vias) should be used to reduce discontinuity for Common mode signal components, as shown in the following figure. Common mode of part of the signal requires continuous return path for TX and RX to GND. Return vias help maintain the continuity.

**Figure 18 • GND Via or Return Via**

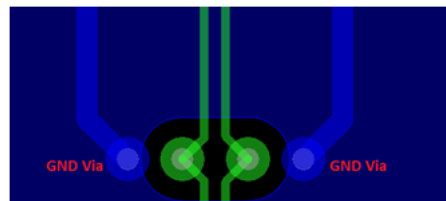

## 4.2.2 DC Blocking Capacitors

The plane underneath the pads of DC blocking capacitors should be removed, as shown in the following figure, to match the impedance of the pad to 50  $\Omega$ .

**Figure 19 • Capacitor Pad Reference Plane**

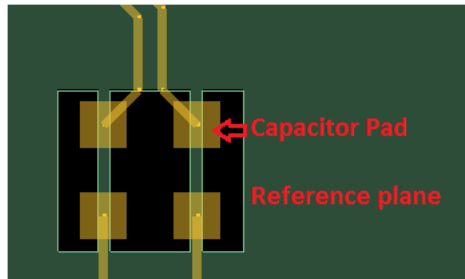

# Mouser Electronics

Authorized Distributor

Click to View Pricing, Inventory, Delivery & Lifecycle Information:

[Microchip:](#)

[MPF300-EVAL-KIT-ES](#)



Компания «ЭлектроПласт» предлагает заключение долгосрочных отношений при поставках импортных электронных компонентов на взаимовыгодных условиях!

Наши преимущества:

- Оперативные поставки широкого спектра электронных компонентов отечественного и импортного производства напрямую от производителей и с крупнейших мировых складов;
- Поставка более 17-ти миллионов наименований электронных компонентов;
- Поставка сложных, дефицитных, либо снятых с производства позиций;
- Оперативные сроки поставки под заказ (от 5 рабочих дней);
- Экспресс доставка в любую точку России;
- Техническая поддержка проекта, помощь в подборе аналогов, поставка прототипов;
- Система менеджмента качества сертифицирована по Международному стандарту ISO 9001;
- Лицензия ФСБ на осуществление работ с использованием сведений, составляющих государственную тайну;
- Поставка специализированных компонентов (Xilinx, Altera, Analog Devices, Intersil, Interpoint, Microsemi, Aeroflex, Peregrine, Syfer, Eurofarad, Texas Instrument, Miteq, Cobham, E2V, MA-COM, Hittite, Mini-Circuits, General Dynamics и др.);

Помимо этого, одним из направлений компании «ЭлектроПласт» является направление «Источники питания». Мы предлагаем Вам помощь Конструкторского отдела:

- Подбор оптимального решения, техническое обоснование при выборе компонента;
- Подбор аналогов;
- Консультации по применению компонента;
- Поставка образцов и прототипов;
- Техническая поддержка проекта;
- Защита от снятия компонента с производства.



#### Как с нами связаться

**Телефон:** 8 (812) 309 58 32 (многоканальный)

**Факс:** 8 (812) 320-02-42

**Электронная почта:** [org@eplast1.ru](mailto:org@eplast1.ru)

**Адрес:** 198099, г. Санкт-Петербург, ул. Калинина, дом 2, корпус 4, литера А.