



CTH Series

Capacitive Touch Sensor Display

15.0 x 15.0 x 11.0 mm



CTHS15CIC04 - White Capacitive Touch Sensor Through Hole with a Display Size of 0.59 x 0.59 inches (15 x 15 mm) square



Applications

- Mobile communication devices
- Electronic devices
- Point of sale Terminals
- Gaming
- Industrial control displays
- Touch Screen Monitors
- Portable Instruments
- Media Players
- Medical devices
- Appliances and consumer equipments

Key Features

- Integrated touch sensing and display technology
- Enables the device interface to be more user friendly and intuitive
- Mounting type: through hole (industry standard pitch 0.100")
- Available in one standard size: 15.0mm x 15.00mm x 11.00mm
- Available in 5 colors: super red, white, pure green, blue or yellow
- Touch sensor: integrated circuit (IC)
- Uniform illumination and high optical clarity due to LED technology
- Robust design due to no mechanical moving parts
- Simplifies devices design and manufacturability
- Optional overlay (icons): on/off, arrow, alarm
- Custom overlay icon can be manufactured upon request - contact VCC
- Compliant with RoHS and REACH requirements

Ordering Data

The CTH Series (Cap Touch) is available in a range of standard features and options. To specify your Cap Touch Display, simply choose one option from each column.

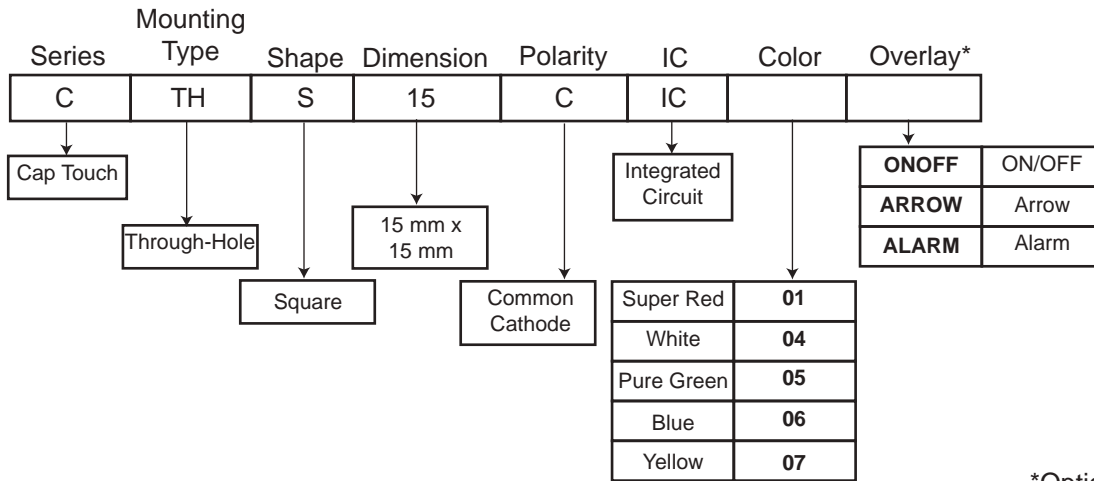



*Optional

Overlay

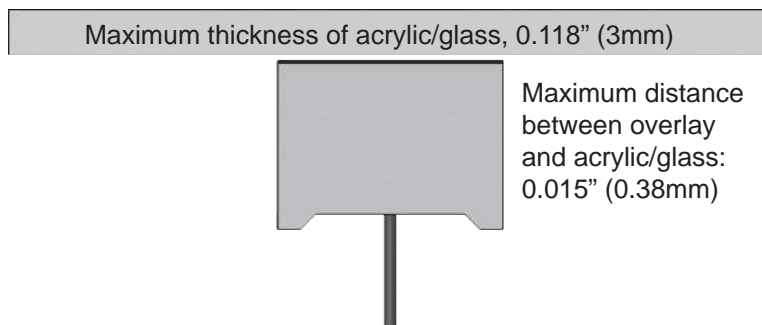
- Different LED colors can indicate the mode in which an electronic device is operating, depending on the icon associated with it.
- Optional graphic overlay made with polished LEXAN™ Polycarbonate 8010 Film 0.007" (0.175 mm) thick has reverse printed translucent white icon, in order to still see it even when the back lighting is off.
- Lexan 8010 is a transparent polycarbonate film and offers hardness, chemical and abrasion resistance, stiffness, and high temperature capability.
- Three standard icons are available: alarm, arrow and on-off. Custom icons are also available upon request.
- Capacitive Touch Display can also be mounted behind clear glass or plastic layer such as polycarbonate or acrylic, as shown in the picture below.



	Overlay On Off
	Overlay Arrow
	Overlay Alarm

Package Dimensions

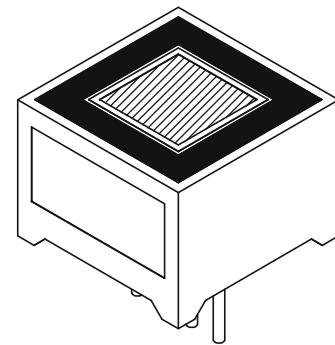
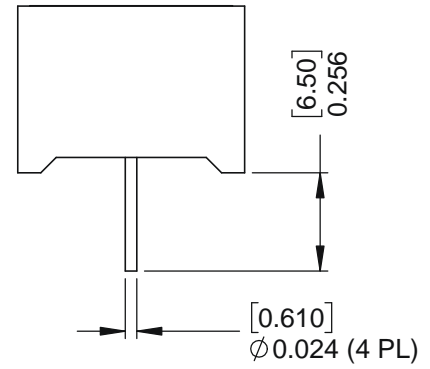
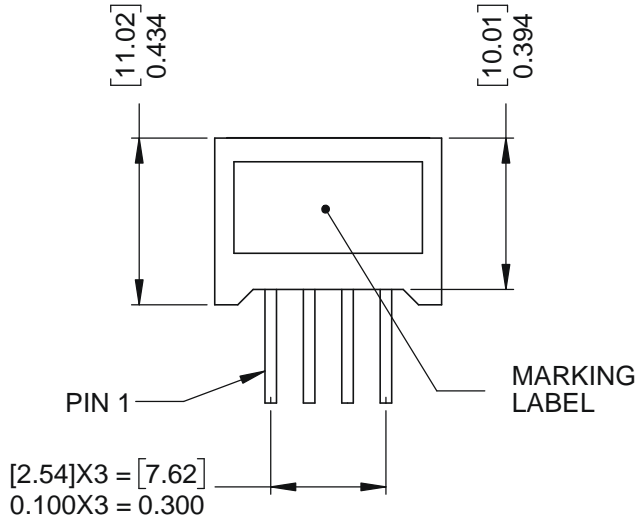

MARKING LABEL INFO

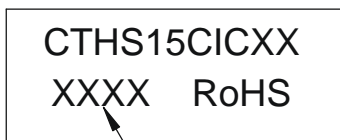

DATE CODE

Dimensions in [mm] inches
General tolerances unless otherwise specified:

	inches	mm
.X	± .020	± .508
.XX	± .010	± .254
.XXX	± .005	± .127

Internal Circuit Diagram

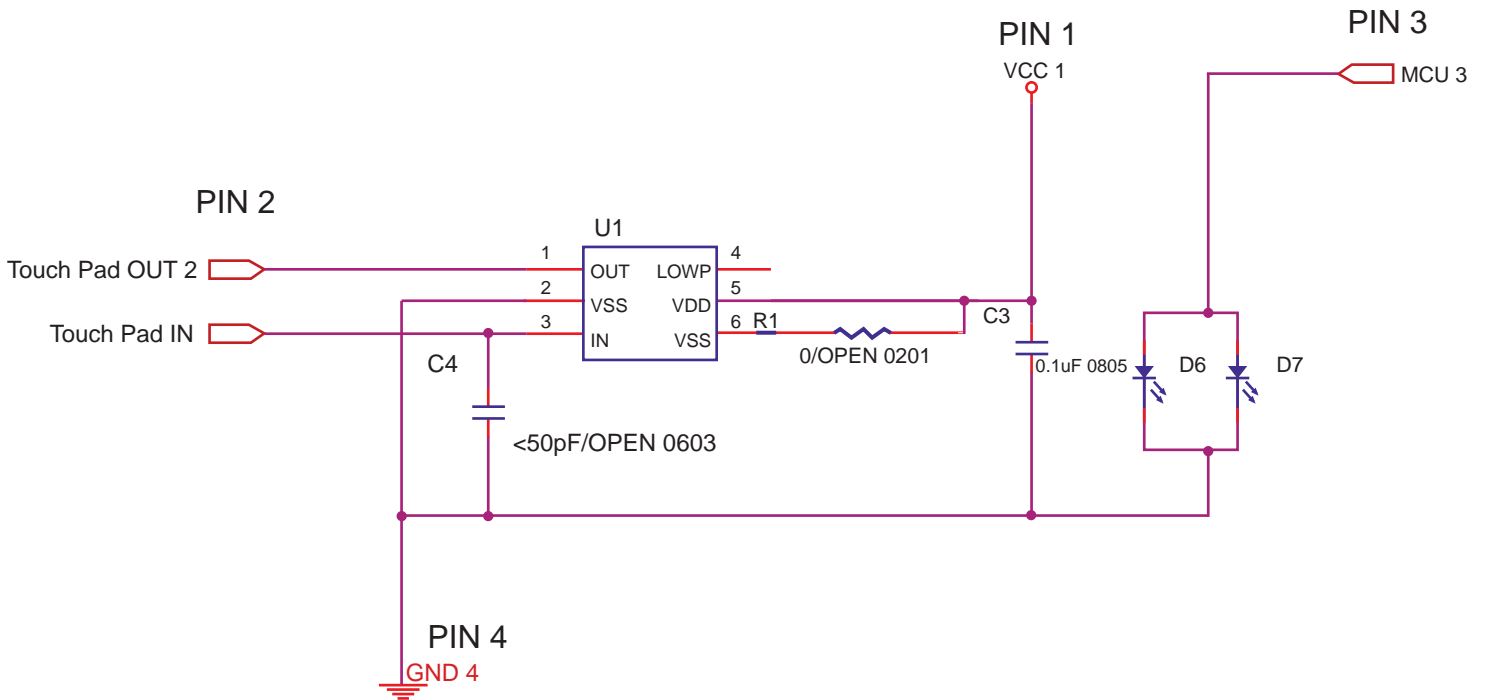

Internal IC Electrical Characteristics

(TA = 25°C, unless otherwise specified)

Symbol	Parameter	Condition	Min.	Typ.	Max.	Units.
VDD	Supply Voltage		2.0		5.5	V
VIH	High Level Input Voltage	@ VDD = 5V	0.7VDD		VDD	V
VIL	Low Level Input Voltage	@ VDD = 5V			0.3VDD	V
IDD1	Operating Current	@ VDD = 5V , no load		16		μA
		@ VDD = 3V , no load		3.5		
IDD2	Operating Current (SLRT=VDD)	@ VDD = 5V , no load		10.5		μA
		@ VDD = 3V , no load		2.5		
IOL	Low Level Output Current	@ VDD = 3V, VOL = 1V		30		mA
IOH	High Level Output Current	@ VDD = 3V, VOL = 2V		8		mA

Product Specifications

ABSOLUTE MAXIMUM RATING FOR LED

(Ta=25°C)

Parameter	Symbol	Rating	Unit
		White	
Power Dissipation Per Dice	PAD	114	mW
Derating Liner from 25°C per Dice	-	0.4	mA/°C
Continuous Forward Current Per Dice	IAF	30	mA
Peak Current Per Dice (duty cycle 1/10,1KHz)	IPF	100	mA
Reverse Voltage Per Dice	VR	5	V
Electrostatic Discharge (HBM)	ESD	1500	V
Operating Temp.	Topr	-35 ~ +85	°C
Storage Temp.	Tstg	-35 ~ +85	°C

ELECTRO-OPTICAL CHARACTERISTICS

(Ta=25°C)

Parameter	Symbol	Min.	Typ.	Max.	Unit	Condition
Luminous Intensity	Iv	133	232	--	mcd	IF = 20 mA
Forward Voltage	VF	--	3.2	3.8	V	IF = 20 mA
Chromaticity Coordinates (Tolerance: ±0.01)	x	--	0.27	--	nm	IF = 10 mA
	y	--	0.25	--	nm	IF = 10 mA
Spectrum Radiation Bandwidth	Iv-M	--	-	2 : 1	--	IF = 10 mA
Luminous Intensity Matching Ratio	IR		-	50	μA	VR = 5V

Product Specifications

ELECTRICAL/OPTICAL CHARACTERISTICS CURVES

(Ta=25°C)

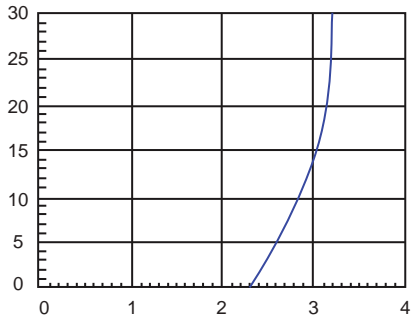

Forward Voltage (V)
Forward Current vs. Forward Voltage

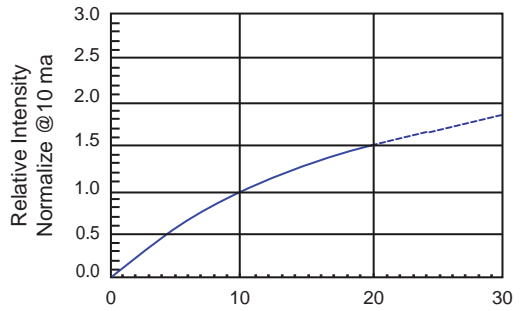

Forward Voltage (mA)
Relative Intensity vs. Forward Current

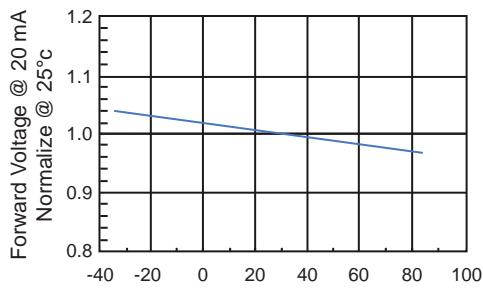

Ambient Temperature (°C)
Forward Voltage vs. Temperature

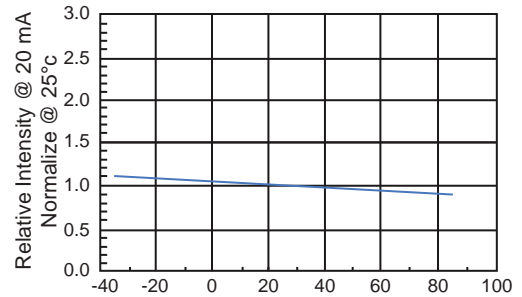

Ambient Temperature (°C)
Relative Intensity vs. Temperature

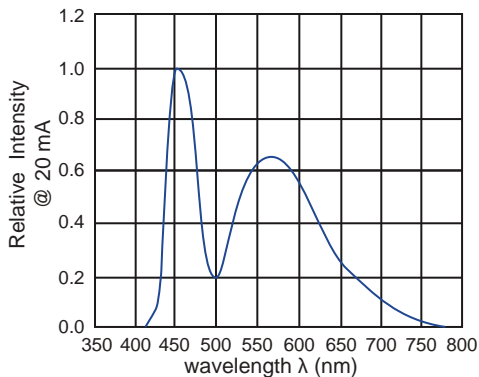

wavelength λ (nm)
Relative Intensity vs. Wavelength

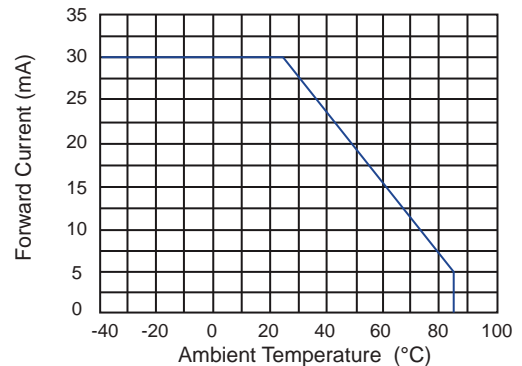

Ambient Temperature (°C)
Forward Current vs. Temperature

Product Specifications

SOLDERING CONDITIONS

1. Wave Soldering Profile

Distance: 1.6mm min (From Seating Plane)

Item	Condition		Note
Preheat	Temperature T1	80 – 120 °C	PWB Temperature (Soldering Side Surface)
	Time t1	60 – 180sec	
Solder Dip	Temperature T2	230 – 260°C	Bath Temperature
	Time t2	2 – 4 sec	Solder Tank Passage Time



2. Hand Soldering (Iron Condition)

Soldering Iron: 30W Max

Temperature 350°C Max

Soldering Time: 3 Seconds Max (One Time)

Distance: 1.6mm min (From Seating Plane)

Application Circuit

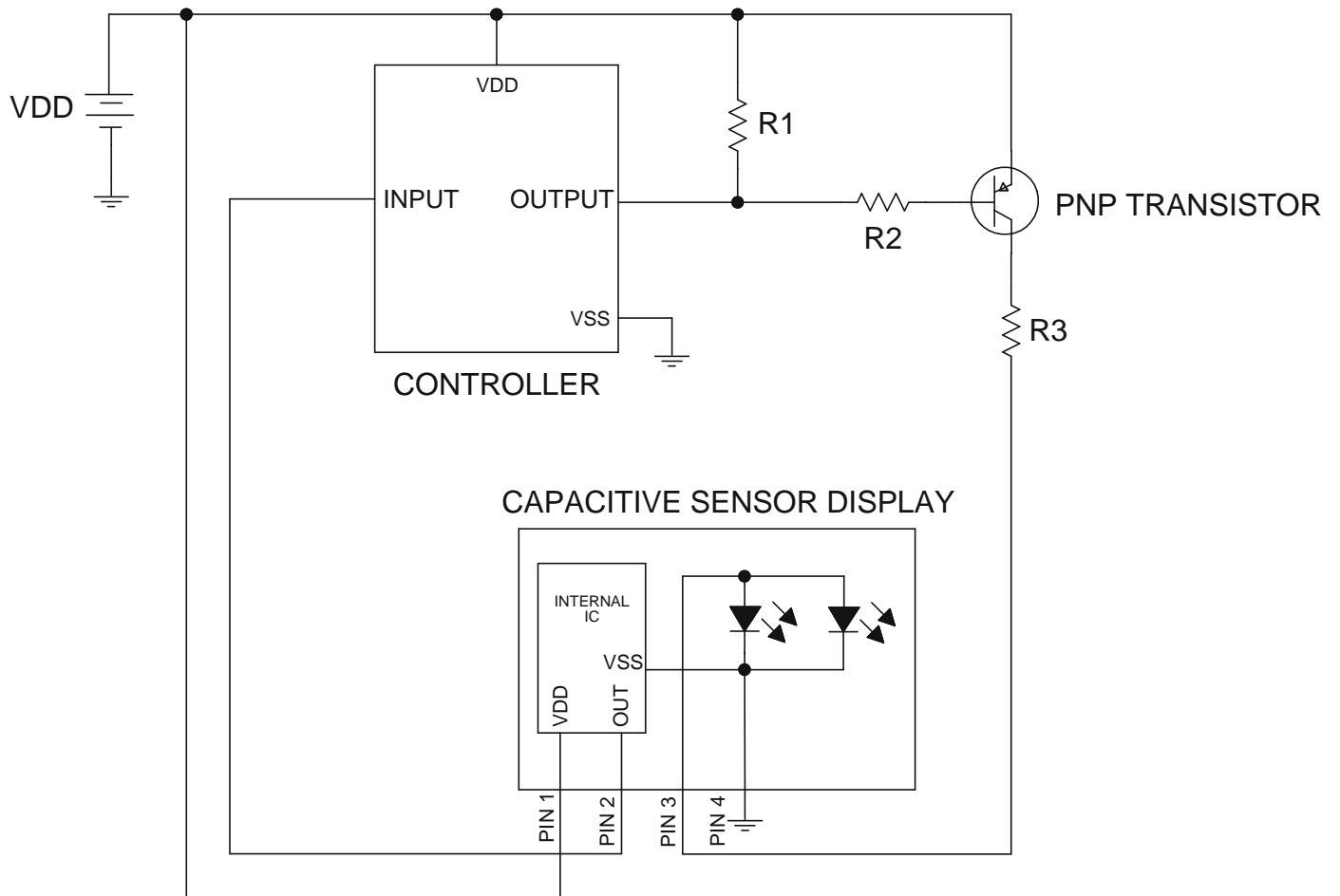

Compliances and Approvals





Компания «ЭлектроПласт» предлагает заключение долгосрочных отношений при поставках импортных электронных компонентов на взаимовыгодных условиях!

Наши преимущества:

- Оперативные поставки широкого спектра электронных компонентов отечественного и импортного производства напрямую от производителей и с крупнейших мировых складов;
- Поставка более 17-ти миллионов наименований электронных компонентов;
- Поставка сложных, дефицитных, либо снятых с производства позиций;
- Оперативные сроки поставки под заказ (от 5 рабочих дней);
- Экспресс доставка в любую точку России;
- Техническая поддержка проекта, помощь в подборе аналогов, поставка прототипов;
- Система менеджмента качества сертифицирована по Международному стандарту ISO 9001;
- Лицензия ФСБ на осуществление работ с использованием сведений, составляющих государственную тайну;
- Поставка специализированных компонентов (Xilinx, Altera, Analog Devices, Intersil, Interpoint, Microsemi, Aeroflex, Peregrine, Syfer, Eurofarad, Texas Instrument, Miteq, Cobham, E2V, MA-COM, Hittite, Mini-Circuits, General Dynamics и др.);

Помимо этого, одним из направлений компании «ЭлектроПласт» является направление «Источники питания». Мы предлагаем Вам помощь Конструкторского отдела:

- Подбор оптимального решения, техническое обоснование при выборе компонента;
- Подбор аналогов;
- Консультации по применению компонента;
- Поставка образцов и прототипов;
- Техническая поддержка проекта;
- Защита от снятия компонента с производства.



Как с нами связаться

Телефон: 8 (812) 309 58 32 (многоканальный)

Факс: 8 (812) 320-02-42

Электронная почта: org@eplast1.ru

Адрес: 198099, г. Санкт-Петербург, ул. Калинина, дом 2, корпус 4, литера А.