

PART NUMBER	DESCRIPTION	SEE SHEET
180190-0000	HOLDER WITHOUT LENS	3
180190-0001	HOLDER WITH LENS	3
180192-0000	COVER LENS ONLY	3

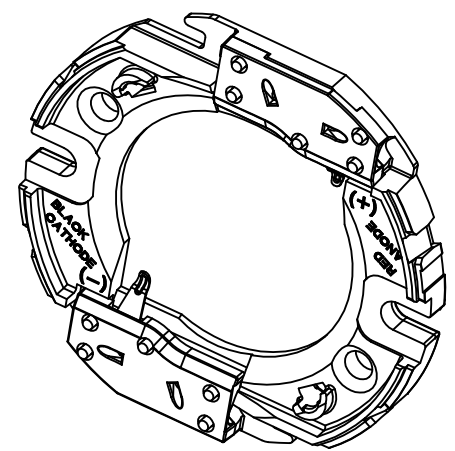

- NOTES:
- MATERIALS:
 - CAPS: NATURAL COLOR PA66 NYLON 25% GF UL94V-0
 - HOUSING: NATURAL COLOR PA66 NYLON 25% GF UL94V-0
 - COVER LENS: CLEAR POLYCARBONATE UL94HB
 - WIRE TRAP TERMINALS: COPPER ALLOY
 - FINISH: GOLD OVER NICKEL
 - THIS PRODUCT IS ELV AND ROHS COMPLIANT
 - APPLICABLE WIRE GAUGE - 18 OR 20 AWG
 - SOLID WIRE IS RECOMMENDED
 - IF STRANDED WIRE IS USED, PRE-TINNED IS RECOMMENDED
 - 1 cm STRIP LENGTH IS RECOMMENDED
 - MOUNT HOLDER USING M3 OR 4-40 SCREWS (2), 0.8 NEWTON METERS MAX TORQUE
 - UL RECOGNIZED TO UL496
c-UL RECOGNIZED TO CSA-C22.2 NO. 43 (2008)
RATED 600V
UL FILE NUMBER: E345583, UL-OLFB2

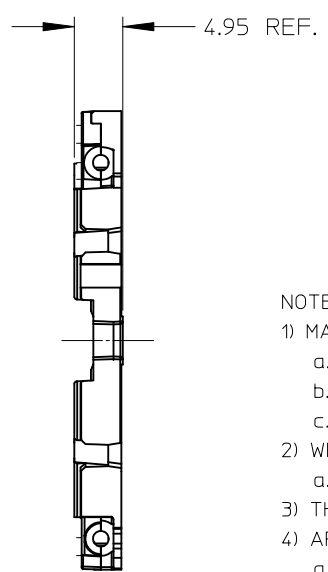
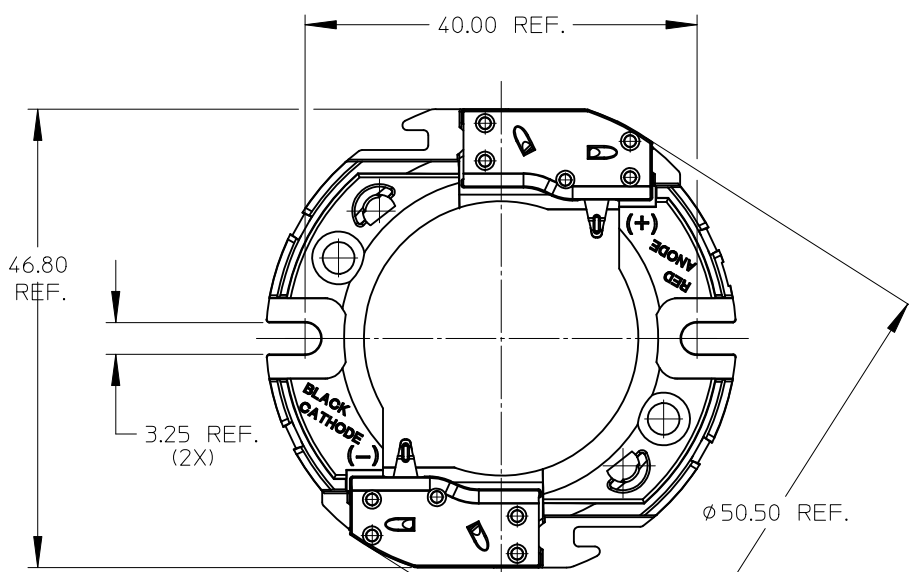
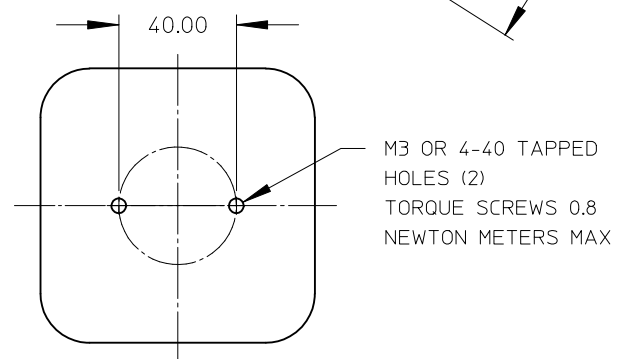

RECOMMENDED MOUNTING DIMENSIONS (NTS)

ENTER DESCRIPTION EC NO: SSL2012-0008 DRW/APP: JAKLIC 2011/08/02 CHKD: APPR: DMCGOWAN 2011/08/05	QUALITY SYMBOLS ▽=0 ▽=0 ▽=0	GENERAL TOLERANCES (UNLESS SPECIFIED)		DIMENSION STYLE MM ONLY		SCALE 2:1	DESIGN UNITS METRIC	THIRD ANGLE PROJECTION		
		4 PLACES	± ---	± ---	DRAWN BY FJAKLIC	DATE 2011/01/28	CITIZEN L-340 LED HOLDER			
		3 PLACES	± ---	± ---	CHECKED BY DATE					
		2 PLACES	± 0.13	± ---	APPROVED BY DMCGOWAN		DATE 2011/02/18	MOLEX INCORPORATED		SHEET NO. 1 OF 3
1 PLACE	± 0.25	± ---	ANGULAR ±1/2°		SEE CHART		DOCUMENT NO. SD-180190-001	THIS DRAWING CONTAINS INFORMATION THAT IS PROPRIETARY TO MOLEX INCORPORATED AND SHOULD NOT BE USED WITHOUT WRITTEN PERMISSION		
DRAFT WHERE APPLICABLE MUST REMAIN WITHIN DIMENSIONS			SIZE B							

10 9 8 7 6 5 4 3 2 1

WIRE TRAP CAPS ARE REMOVED FROM FRONT VIEW FOR CLARITY

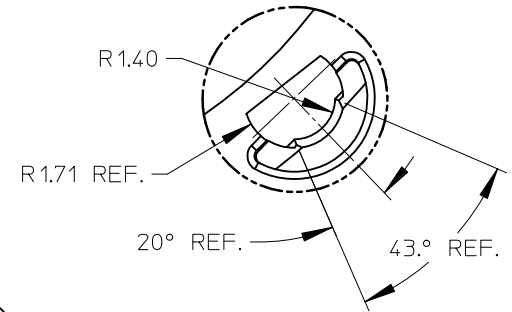
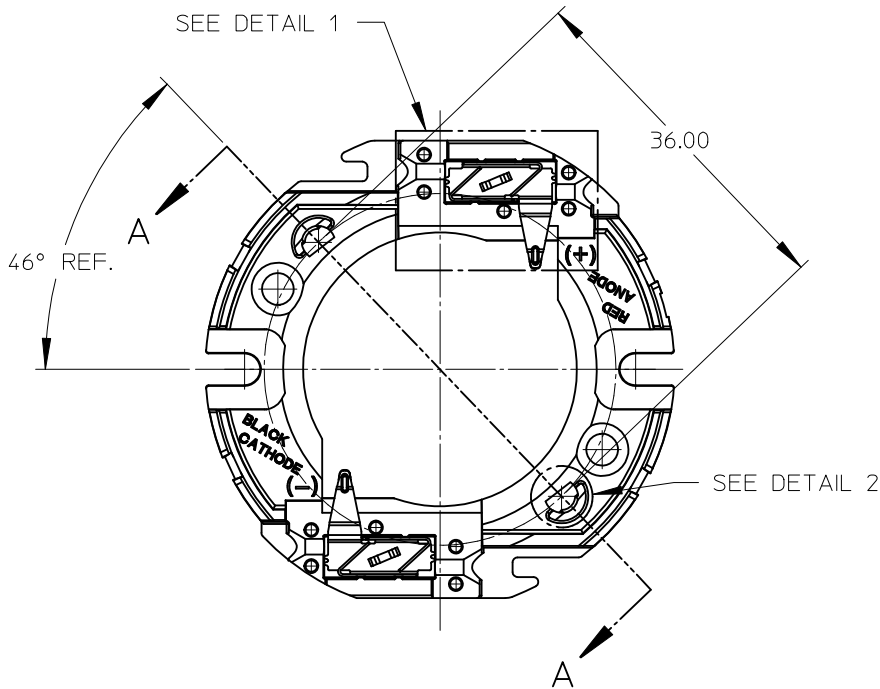

DETAIL 2 SCALE 6:1

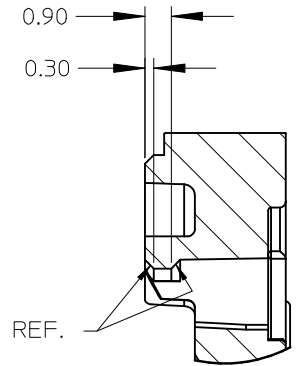
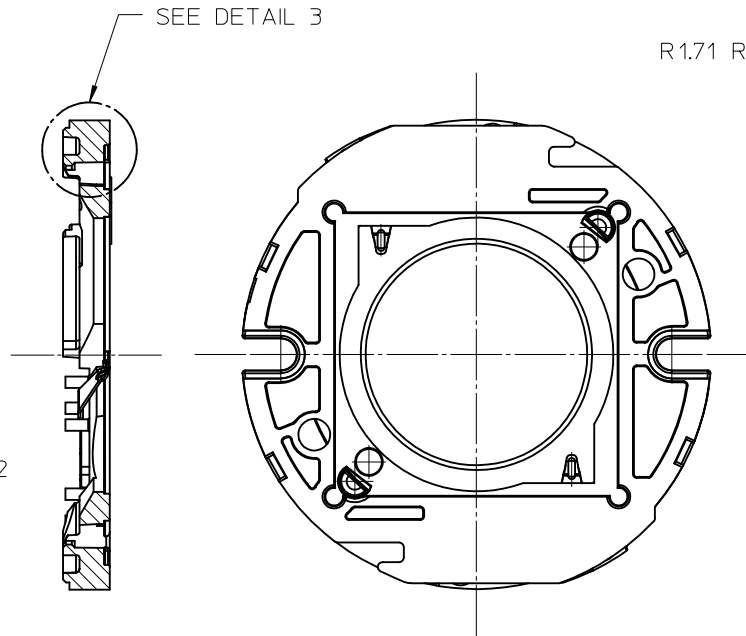

LENS TO HOLDER SNAP FIT DETAIL

DETAIL 3 SCALE 6:1

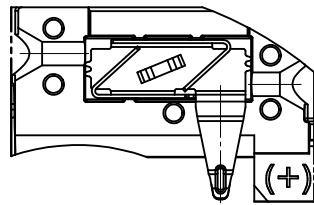

VIEW OF TWO-WAY WIRE TRAP

WIRE TRAPS WILL ACCOMODATE
EITHER 18 OR 20 GAUGE WIRE

DETAIL 1 SCALE 3:1

ENTER DESCRIPTION EC NO: SSL2012-0008 DRAWN: JAKLIC 2011/08/02 CHKD: JAKLIC APPR: DMCGOWAN 2011/08/05 DESCRIPTION REV	QUALITY SYMBOLS	GENERAL TOLERANCES (UNLESS SPECIFIED)	DIMENSION STYLE	SCALE	DESIGN UNITS	THIRD ANGLE PROJECTION
	▽=0	mm INCH	MM ONLY	2:1	METRIC	⊙ □
	▽=0	4 PLACES ± --- ± ---	DRAWN BY DATE	CITIZEN L-340 LED HOLDER MOLEX INCORPORATED		
	▽=0	3 PLACES ± --- ± ---	FJAKLIC 2011/01/28			
▽=0	2 PLACES ± 0.13 ± ---	CHECKED BY DATE	MOLEX INCORPORATED SD-180190-001			
▽=0	1 PLACE ± 0.25 ± ---	DMCGOWAN 2011/02/18				
	ANGULAR ± 1/2°	APPROVED BY DATE	DOCUMENT NO.	SHEET NO. 2 OF 3		
	DRAFT WHERE APPLICABLE MUST REMAIN WITHIN DIMENSIONS	MATERIAL NO.				
		SEE CHART	THIS DRAWING CONTAINS INFORMATION THAT IS PROPRIETARY TO MOLEX INCORPORATED AND SHOULD NOT BE USED WITHOUT WRITTEN PERMISSION			

9 8 7 6 5 4 3 2 1

10 9 8 7 6 5 4 3 2 1

F

E

D

C

B

A

F

E

D

C

B

A

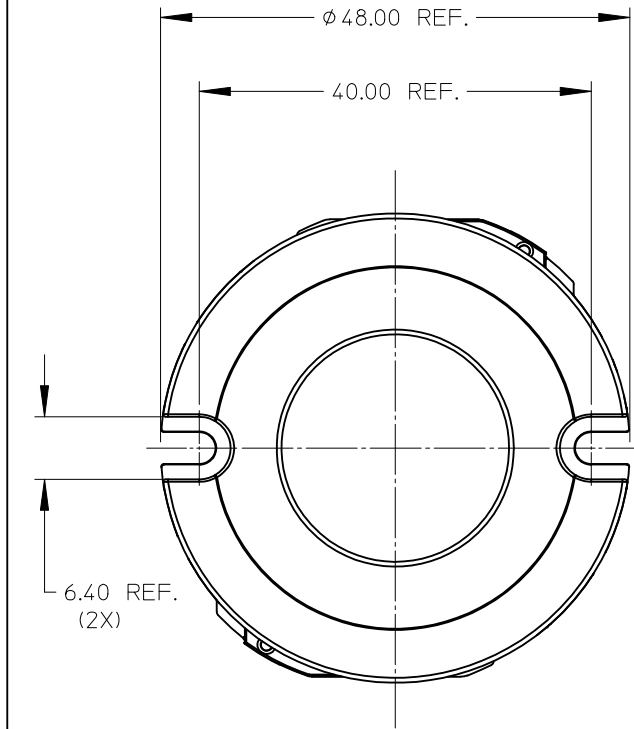
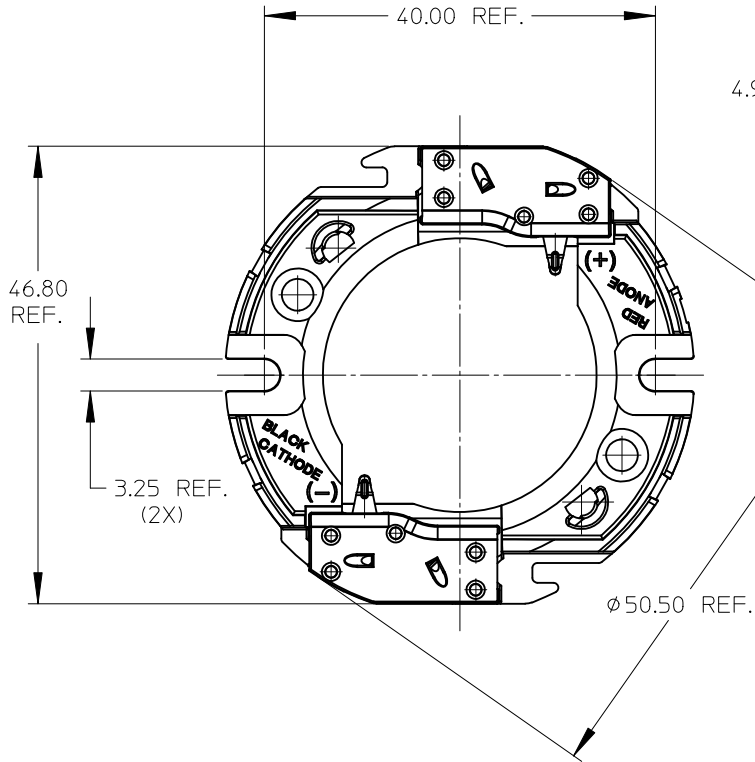
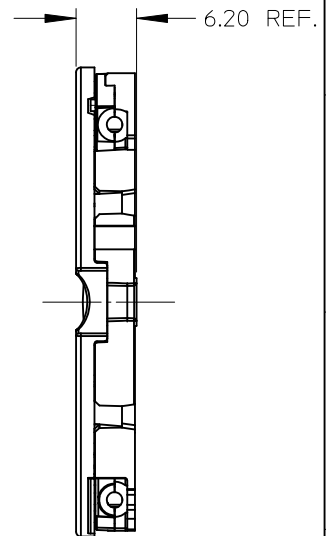
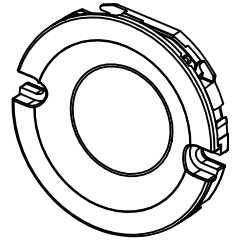
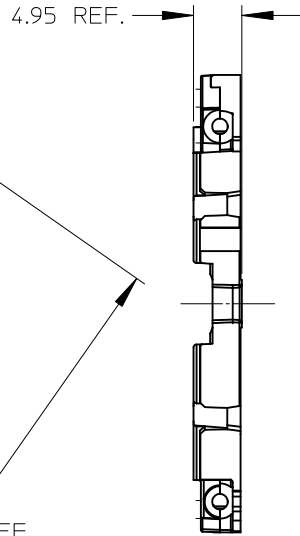
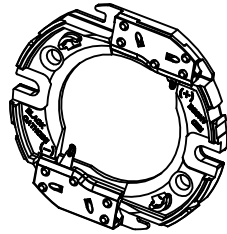

LED HOLDER SHOWN WITH OPTIONAL CLEAR COVER LENS
 MOLEX INDIVIDUAL COVER LENS PART NUMBER IS 180192-0000

LED HOLDER PART NUMBER 180190-0000

ENTER DESCRIPTION EC NO: SSL2012-0008 DRAWN: JAKLIC 2011/08/02 CHKD: APPR: DMCGOWAN 2011/08/05 REV	QUALITY SYMBOLS ▽/0 ▽/0 ▽/0	GENERAL TOLERANCES (UNLESS SPECIFIED) mm INCH 4 PLACES ± --- ± --- 3 PLACES ± --- ± --- 2 PLACES ± 0.13 ± --- 1 PLACE ± 0.25 ± --- ANGULAR ± 1/2°	DIMENSION STYLE MM ONLY DRAWN BY DATE FJAKLIC 2011/01/28 CHECKED BY DATE	SCALE 2:1 TITLE CITIZEN L-340 LED HOLDER	DESIGN UNITS METRIC THIRD ANGLE PROJECTION
	APPROVED BY DATE DMCGOWAN 2011/02/18	MOLEX INCORPORATED	MATERIAL NO.	DOCUMENT NO. SD-180190-001	SHEET NO. 3 OF 3
	DRAFT WHERE APPLICABLE MUST REMAIN WITHIN DIMENSIONS	SEE CHART	THIS DRAWING CONTAINS INFORMATION THAT IS PROPRIETARY TO MOLEX INCORPORATED AND SHOULD NOT BE USED WITHOUT WRITTEN PERMISSION		

9 8 7 6 5 4 3 2 1



Компания «ЭлектроПласт» предлагает заключение долгосрочных отношений при поставках импортных электронных компонентов на взаимовыгодных условиях!

Наши преимущества:

- Оперативные поставки широкого спектра электронных компонентов отечественного и импортного производства напрямую от производителей и с крупнейших мировых складов;
- Поставка более 17-ти миллионов наименований электронных компонентов;
- Поставка сложных, дефицитных, либо снятых с производства позиций;
- Оперативные сроки поставки под заказ (от 5 рабочих дней);
- Экспресс доставка в любую точку России;
- Техническая поддержка проекта, помощь в подборе аналогов, поставка прототипов;
- Система менеджмента качества сертифицирована по Международному стандарту ISO 9001;
- Лицензия ФСБ на осуществление работ с использованием сведений, составляющих государственную тайну;
- Поставка специализированных компонентов (Xilinx, Altera, Analog Devices, Intersil, Interpoint, Microsemi, Aeroflex, Peregrine, Syfer, Eurofarad, Texas Instrument, Miteq, Cobham, E2V, MA-COM, Hittite, Mini-Circuits, General Dynamics и др.);

Помимо этого, одним из направлений компании «ЭлектроПласт» является направление «Источники питания». Мы предлагаем Вам помощь Конструкторского отдела:

- Подбор оптимального решения, техническое обоснование при выборе компонента;
- Подбор аналогов;
- Консультации по применению компонента;
- Поставка образцов и прототипов;
- Техническая поддержка проекта;
- Защита от снятия компонента с производства.



Как с нами связаться

Телефон: 8 (812) 309 58 32 (многоканальный)

Факс: 8 (812) 320-02-42

Электронная почта: org@eplast1.ru

Адрес: 198099, г. Санкт-Петербург, ул. Калинина, дом 2, корпус 4, литера А.