

NEW



High-Current Connector DW05 Series

CONNECTOR
MB-0283-1
August 2014

RoHS Compliant

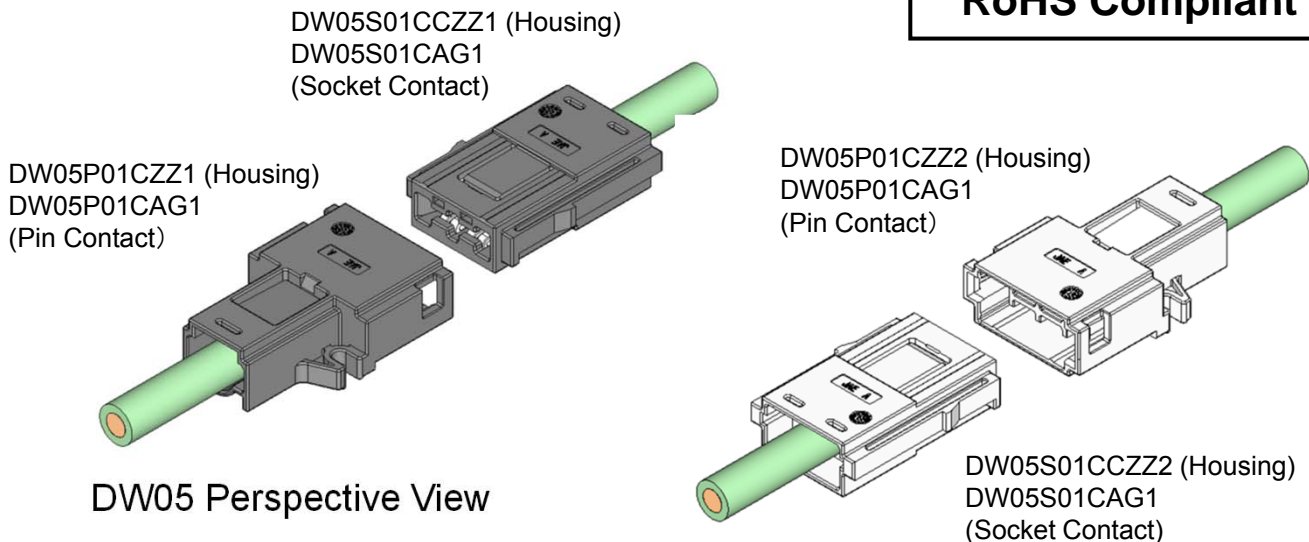

《Summary》

Along with the spread of energy management systems in recent years, the introduction of storage battery system using lithium-ion is becoming widespread.

As for the systems like storage battery one using high current, the importance is attached to the safety at the time of assembly work and maintenance. So there are a lot of demands for connection methods that can prevent incorrect wiring and short circuit accidents.

JAE has now developed the 150A-class high-current connector “DW05 Series” which can realize a safe connection in the situation using such high current.

The contacts of the DW05 Series cannot be touched easily, and from the difference in the mating shape, the connection between the opposite polarities cannot be made. So it is possible to prevent short circuit accidents between the opposite polarities and realize a high level of safety.

Also, it contributes to shorten work time for customers by simplifying connection work with an easy operation lock structure equipped between the connectors, which can provide adequate strength as well as screw fixing.

The DW05 Series features a multi-contact structure compatible with high-current connection and also has superior connection stability.

Features

- Improved Workability: With mis-mating prevention key to avoid wrong wiring and short-circuit during assembly.

- High Safety: With structure to prevent finger tips from touching the terminal to avoid electrical shock.

Mis-connection of positive and negative polarity terminals prevented by using 2 different colors for insulator (ivory and black), and a different mating shape for each.

- Termination: Crimp termination considering on-site assembly.

Conductor cross-section of standard cable is 38 mm². (Cable of 26 to 42 mm² in the same shape is possible to be used)

General Specifications

- No. of Contacts: 1 pos.
- Operating Temperature: -40 Deg. C to +85 Deg. C
- Rated Current: 150A, DC150A (Temperature rise : 40 Deg. C max.)
- Contact Resistance: 0.2m Ω max. (initial)
0.3m Ω max. (after various tests)

Ordering Information

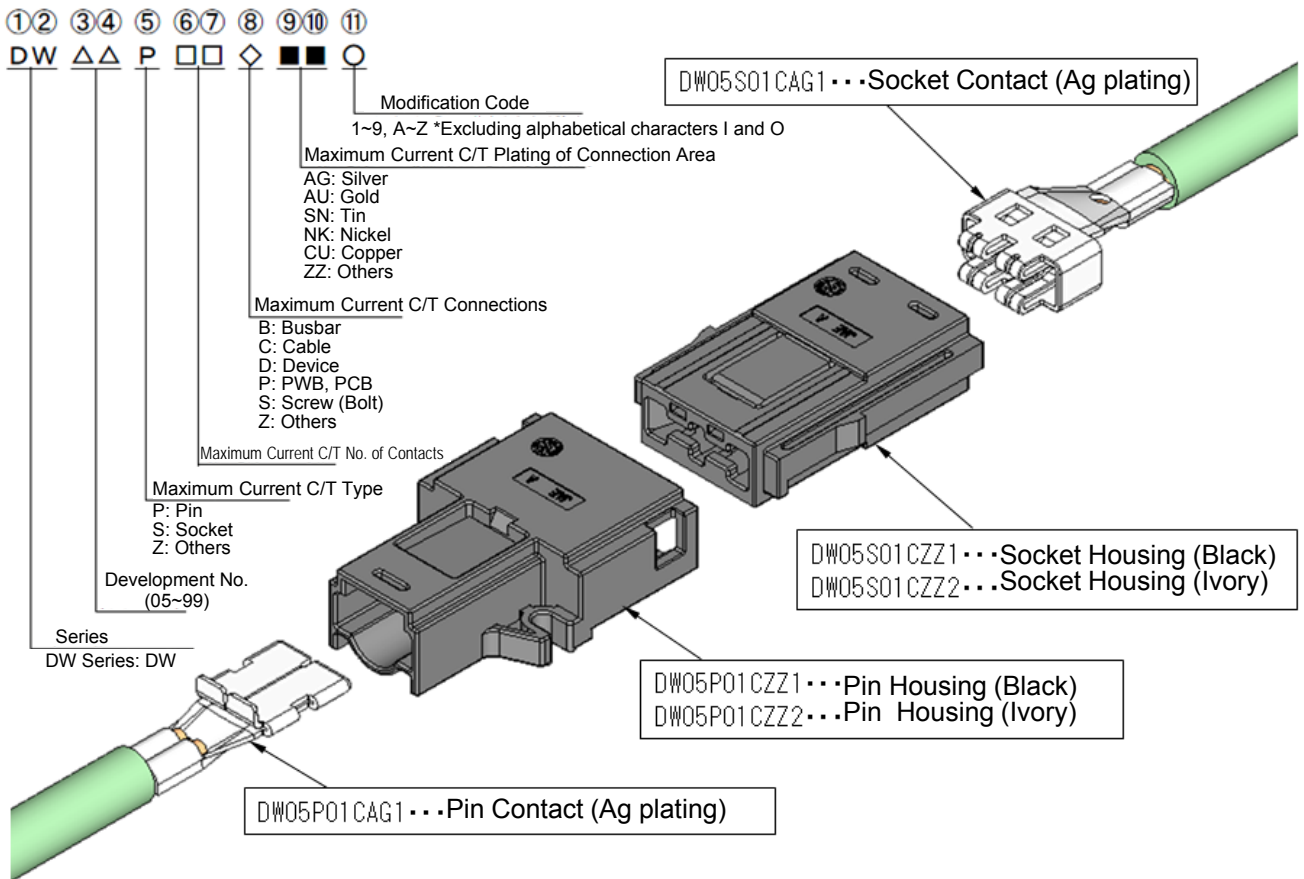

Product Drawing

1. Pin Housing, Black (Main Unit)

Part Number	DW05P01CZZ1
SJ Drawing	SJ114759

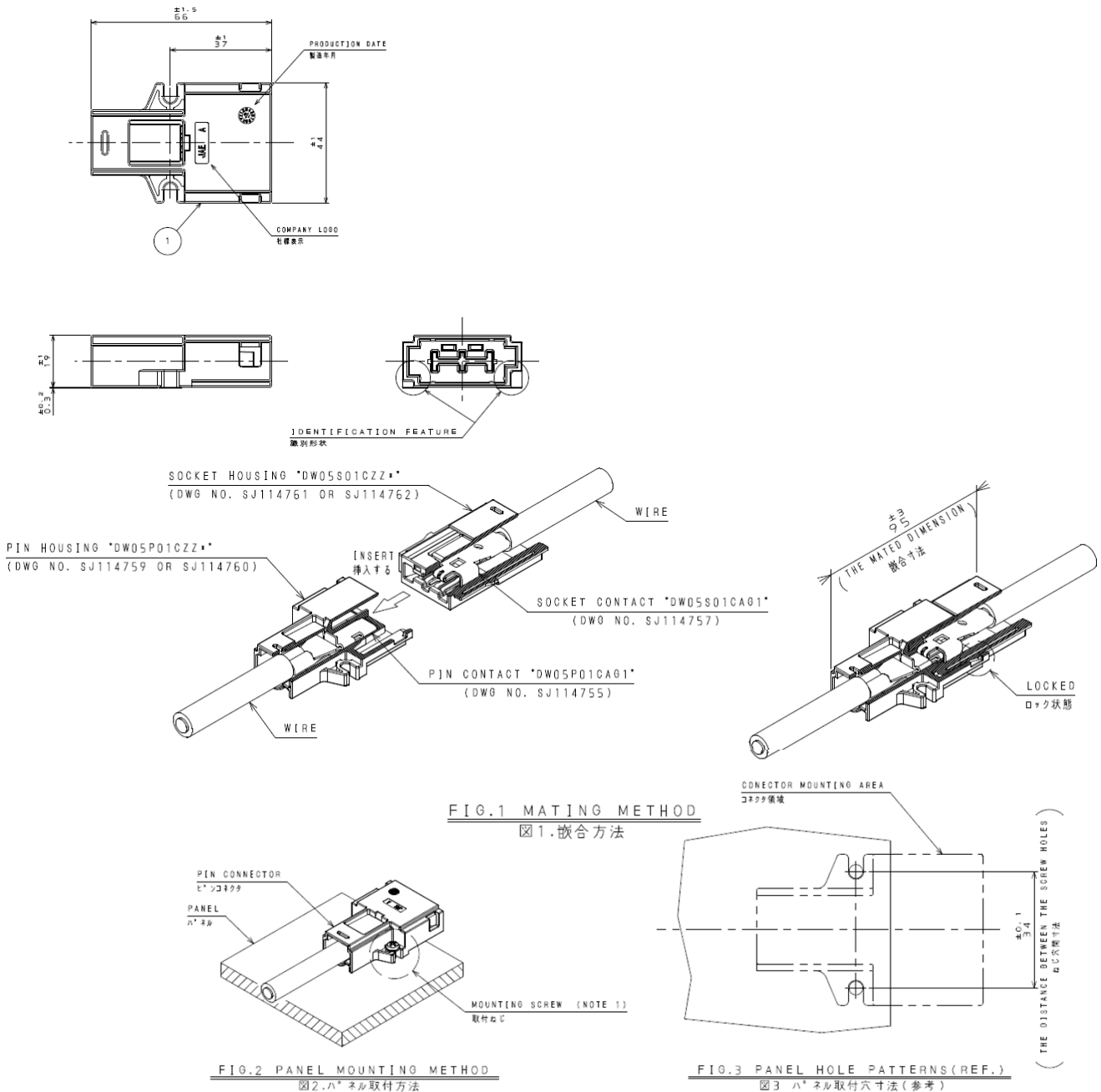

NOTE 1. RECOMMENDATION MOUNTING SCREW IS CROSS RECESSED HEAD SCREW.
THE SCREW-TIGHTENING TORQUE SHALL BE 1.48 N/m.

注1. 推奨取付ねじは、『十字穴付き小ねじ』とする。
取付ねじの締付トルクは、1.48N/mとする。

1	HOUSING ハウジング	1	GLASS FILLED PBT ガラス入りPBT	COLOR : BLACK 色相 : 黒色
符号 NO.	名称 DESCRIPTION	個数 QTY.	材料 MATERIAL	仕上 FINISH

2. Pin Housing, Ivory (Main Unit)

Part Number	DW05P01CZZ2
SJ Drawing	SJ114760

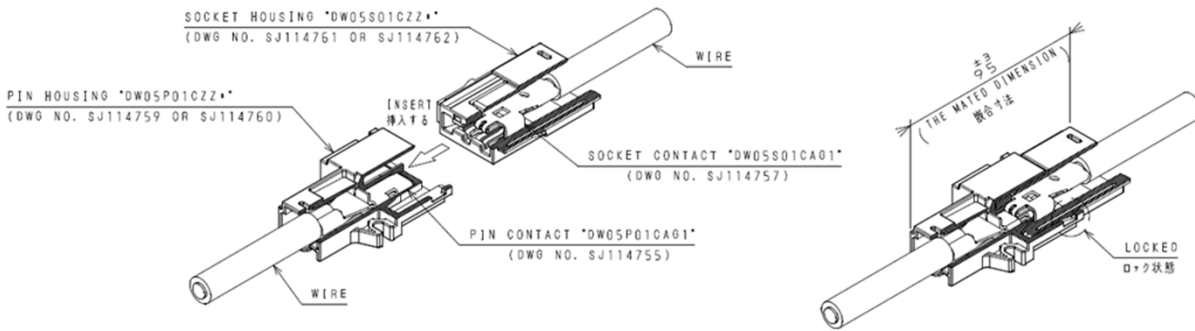
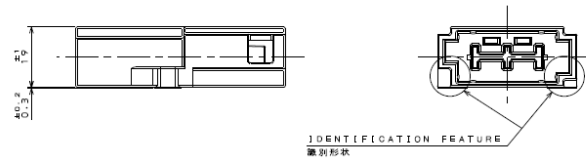
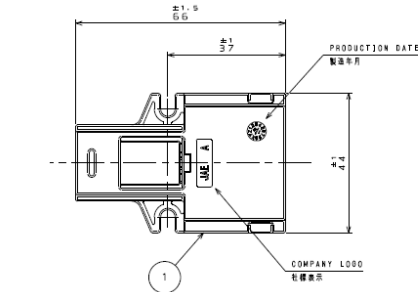

FIG.1 MATING METHOD
図1.嵌合方法

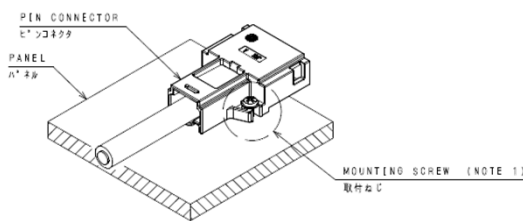

FIG.2 PANEL MOUNTING METHOD
図2.パネル取付方法

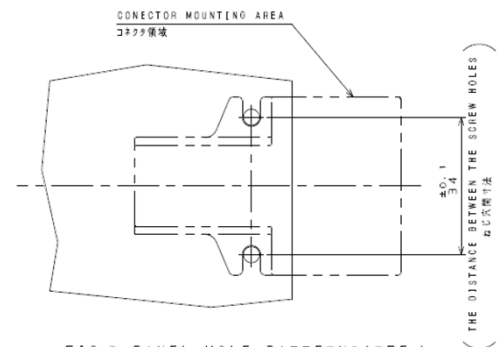

FIG.3 PANEL HOLE PATTERNS (REF.)
図3.パネル取付寸法(参考)

NOTE 1. RECOMMENDATION MOUNTING SCREW IS CROSS RECESSED HEAD SCREW.
THE SCREW-TIGHTENING TORQUE SHALL BE 1.48 N/m.

注1. 推奨取付ねじは、「十字穴付き小ねじ」とする。
取付ねじの締付トルクは、1.48N/mとする。

1	HOUSING ハウジング*	1	GLASS FILLED PBT ガラス入りPBT	COLOR : IVORY 色相 : アイホリ
符号 NO.	名 DESCRIPTION	個数 QTY.	材 MATERIAL	仕 FINISH

3. Pin Contact (Ag Plating)

Part Number	DW05P01CAG1
SJ Drawing	SJ114755

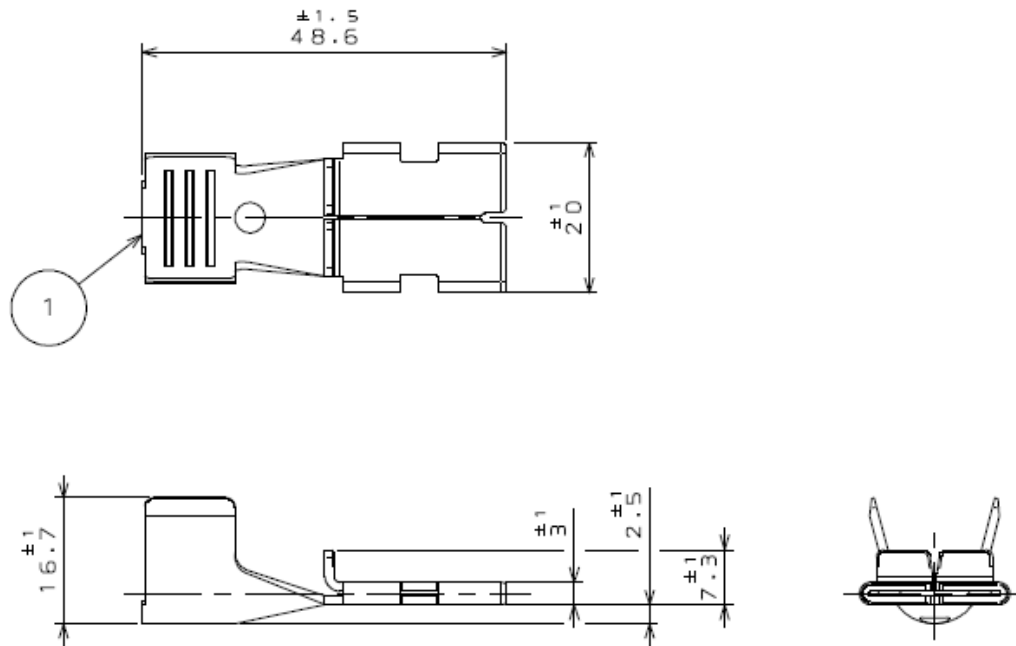

NOTE 1.

・ APPLICABLE WIRE

WIRE SIZE : 26mm² ~ 42mm²

AWG #2

INSULATION DIAMETER : φ 13.0mm MAX.

注 1.

・ 適合電線

導体サイズ : 26mm² ~ 42mm²

AWG #2

被覆外径 : φ 13.0mm 以下

1	CONTACT	1	COPPER ALLOY	SILVER PLATING	
符号	名 称	個 数	材 料	仕 上	備 考
NO.	DESCRIPTION	QTY.	MATERIAL	FINISH	REMARKS

4. Socket Housing, Black (Main Unit)

Part Number	DW05S01CZZ1
SJ Drawing	SJ114761

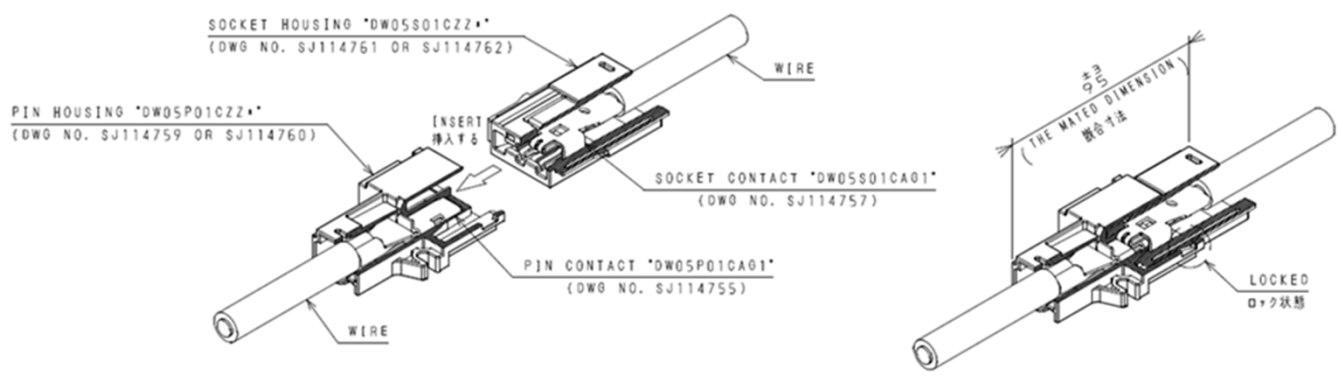
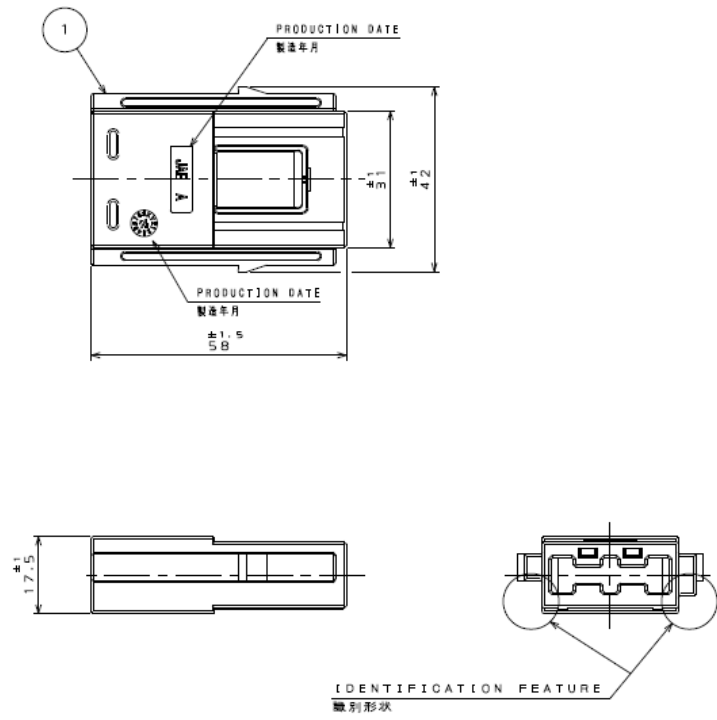

FIG.1 MATING METHOD
図1.嵌合方法

1	HOUSING ハウジング*	1	GLASS FILLED PBT ガラス入りPBT	COLOR : BLACK 色相 : 黒色	
符号 NO.	名称 DESCRIPTION	個数 QTY.	材料 MATERIAL	仕上 FINISH	備考 REMARKS

5. Socket Housing, Ivory (Main Unit)

Part Number	DW05S01CZZ2
SJ Drawing	SJ114762

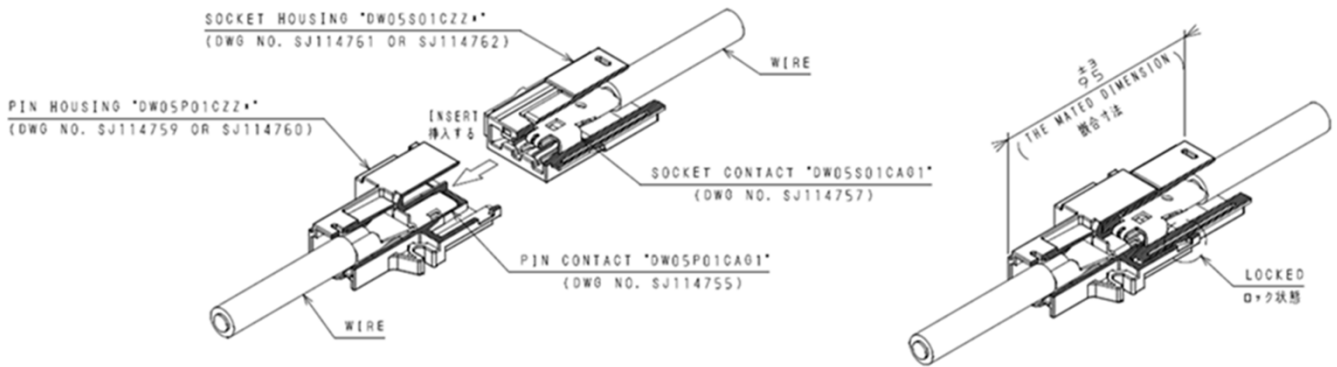
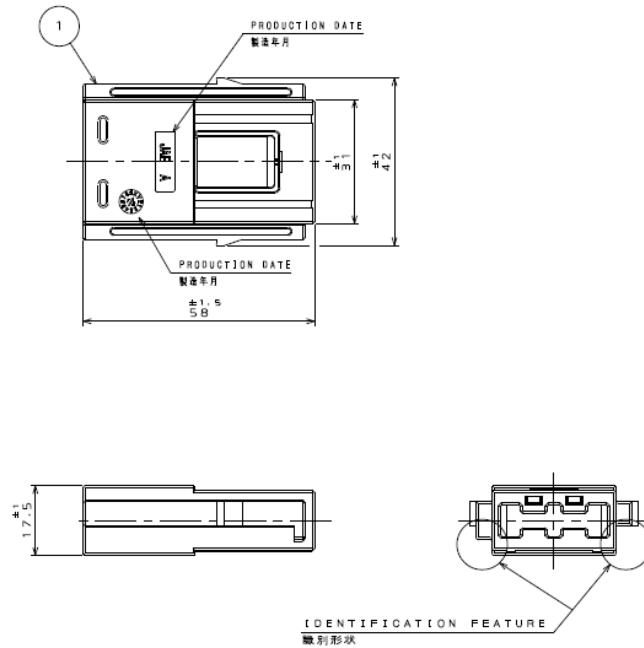
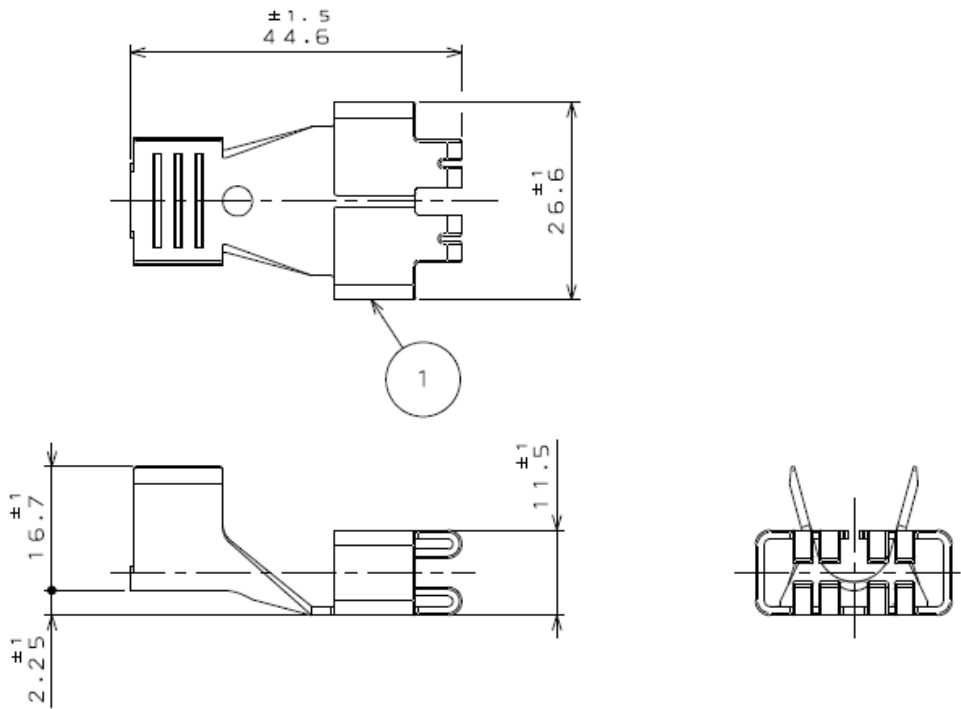

FIG.1 MATING METHOD
図1. 嵌合方法

1	HOUSING ハウジング*	1	GLASS FILLED PBT ガラス入りPBT	COLOR : [IVORY 色相 : アイボリー	
符号 NO.	名称 DESCRIPTION	個数 QTY.	材料 MATERIAL	仕上 FINISH	備考 REMARKS

6. Socket Contact (Ag Plating)

Part Number	DW05S01CAG1
SJ Drawing	SJ114757



NOTE 1.

・ APPLICABLE WIRE

WIRE SIZE: 26mm² ~ 42mm²

AWG# 2

INSULATION DIAMETER: φ 13.0mm MAX.

注 1.

・ 適合電線

導体サイズ* : 26mm² ~ 42mm²

AWG# 2

被覆外径 : φ 13.0mm 以下

1	CONTACT コンタクト	1	COPPER ALLOY 銅合金	SILVER PLATING 銀めっき	
符号 NO.	名 称 DESCRIPTION	個 数 QTY.	材 料 MATERIAL	仕 上 FINISH	備 考 REMARKS

Technical Documents

	Technical Document No. (Document Content)
Product Drawings	SJ114759 (DW05 Pin Housing, Black) SJ114760 (DW05 Pin Housing, Ivory) SJ114755 (DW05 Pin Contact, Ag Plating) SJ114761 (DW05 Socket Housing ,Black) SJ114762 (DW05 Socket Housing, Ivory) SJ114757 (DW05 Socket Contact, Ag Plating)
Specifications	JACS-30349

Notice:

1. The values specified in this brochure are only for reference. The products and their specifications are subject to change without notice. Contact our sales staff for further information before considering or ordering any of our products. For purchase, a product specification must be agreed upon.

2. Users are requested to provide protection circuits and redundancy circuits to ensure safety of the equipment, and sufficiently review the suitability of JAE's products to the equipment.

3. The products presented in this brochure are designed for the uses recommended below. We strongly suggest you contact our sales staff when considering use of any of the products in any other way than the recommended applications or for a specific use that requires an extremely high reliability.

(1) Applications that require consultation:

(i) Please contact us if you are considering use involving a quality assurance program that you specify or that is peculiar to the industry, such as:

Automotive electrical components, train control, telecommunications devices (mainline), traffic light control, electric power, combustion control, fire prevention or security systems, disaster prevention equipment, etc.

(ii) We may separately give you our support with a quality assurance program that you specify, when you think of a use such as :

Aviation or space equipment, submarine repeaters, nuclear power control systems, medical equipment for life support, etc.

(2) Recommended applications include:

Computers, office appliances, telecommunications devices (terminals, mobile units), measuring equipment, audiovisual equipment, home electric appliances, factory automation equipment, etc

Japan Aviation Electronics Industry, Limited

Product Marketing Division

Aobadai Building, 3-1-19, Aobadai, Meguro-ku, Tokyo 153-8539

Phone: +81-3-3780-2882 FAX: +81-3-3780-2946

* The specifications in this brochure are subject to change without notice. Please contact JAE for information.



Компания «ЭлектроПласт» предлагает заключение долгосрочных отношений при поставках импортных электронных компонентов на взаимовыгодных условиях!

Наши преимущества:

- Оперативные поставки широкого спектра электронных компонентов отечественного и импортного производства напрямую от производителей и с крупнейших мировых складов;
- Поставка более 17-ти миллионов наименований электронных компонентов;
- Поставка сложных, дефицитных, либо снятых с производства позиций;
- Оперативные сроки поставки под заказ (от 5 рабочих дней);
- Экспресс доставка в любую точку России;
- Техническая поддержка проекта, помощь в подборе аналогов, поставка прототипов;
- Система менеджмента качества сертифицирована по Международному стандарту ISO 9001;
- Лицензия ФСБ на осуществление работ с использованием сведений, составляющих государственную тайну;
- Поставка специализированных компонентов (Xilinx, Altera, Analog Devices, Intersil, Interpoint, Microsemi, Aeroflex, Peregrine, Syfer, Eurofarad, Texas Instrument, Miteq, Cobham, E2V, MA-COM, Hittite, Mini-Circuits, General Dynamics и др.);

Помимо этого, одним из направлений компании «ЭлектроПласт» является направление «Источники питания». Мы предлагаем Вам помощь Конструкторского отдела:

- Подбор оптимального решения, техническое обоснование при выборе компонента;
- Подбор аналогов;
- Консультации по применению компонента;
- Поставка образцов и прототипов;
- Техническая поддержка проекта;
- Защита от снятия компонента с производства.



Как с нами связаться

Телефон: 8 (812) 309 58 32 (многоканальный)

Факс: 8 (812) 320-02-42

Электронная почта: org@eplast1.ru

Адрес: 198099, г. Санкт-Петербург, ул. Калинина, дом 2, корпус 4, литера А.