DataSheet

System Configuration	2
G5 Series AC Servomotor/Servo Drives with built-in EtherCAT Communications ..	2
G5 Series Linear Motor/Servo Drives with built-in EtherCAT Communications	
Linear Motor Type.....	4
G5-series AC Servomotors/Servo Drives with General-purpose Pulse Train	
or Analog Inputs	6
G5-series AC Servomotors/Servo Drives with Built-in MECHATROLINK-II	
Communications.....	8
G5-series AC Servo Drives with Built-in EtherCAT Communications.....	10
Contents	
Ordering Information	
Specifications	
Components and Functions	
Dimensions	
G5-series AC Servo Drives with Built-in EtherCAT Communications Linear	
Motor Type	22
Contents	
Ordering Information	
Specifications	
Components and Functions	
Dimensions	
G5-Series AC Servo Drives with General-purpose Pulse Train or Analog Inputs.....	27
Contents	
Ordering Information	
Specifications	
Components and Functions	
Dimensions	
G5-series AC Servo Drives with Built-in MECHATROLINK-II Communications	38
Contents	
Ordering Information	
Specifications	
Components and Functions	
Dimensions	
G5-series AC Servomotors	47
Contents	
Ordering Information	
Specifications	
Dimensions	
G5-series Linear Motor	74
Contents	
Ordering Information	
Specifications	
Components and Functions	
Dimensions	
Related Manuals	89

Sysmac® is a trademark or registered trademark of OMRON Corporation in Japan and other countries for OMRON factory automation products.

Windows is registered trademarks of Microsoft Corporation in the USA and other countries.

EtherCAT® is a registered trademark of Beckhoff Automation GmbH for their patented technology.

Other company names and product names in this document are the trademarks or registered trademarks of their respective companies.

As a Sysmac Device, the G5-series AC Servomotor/Servo Drive with Built-in EtherCAT Communications is designed to provide optimal functionality and enhanced operability when used in conjunction with a Machine Automation Controller such as NJ series and the automation software Sysmac Studio. Sysmac Device is a generic term for OMRON control devices such as an EtherCAT Slave, designed with unified communications specifications and user interface specifications.

When connecting a Servo Drive to the NJ5 series Machine Automation Controller, it is recommended that you use the Servo Drive with Built-in EtherCAT Communications, R88D-KN□□□-ECT, with unit version 2.1 or later.

G5 Series AC Servomotor/Servo Drives with built-in EtherCAT Communications

R88M-K/R88D-KN□-ECT

System Configuration

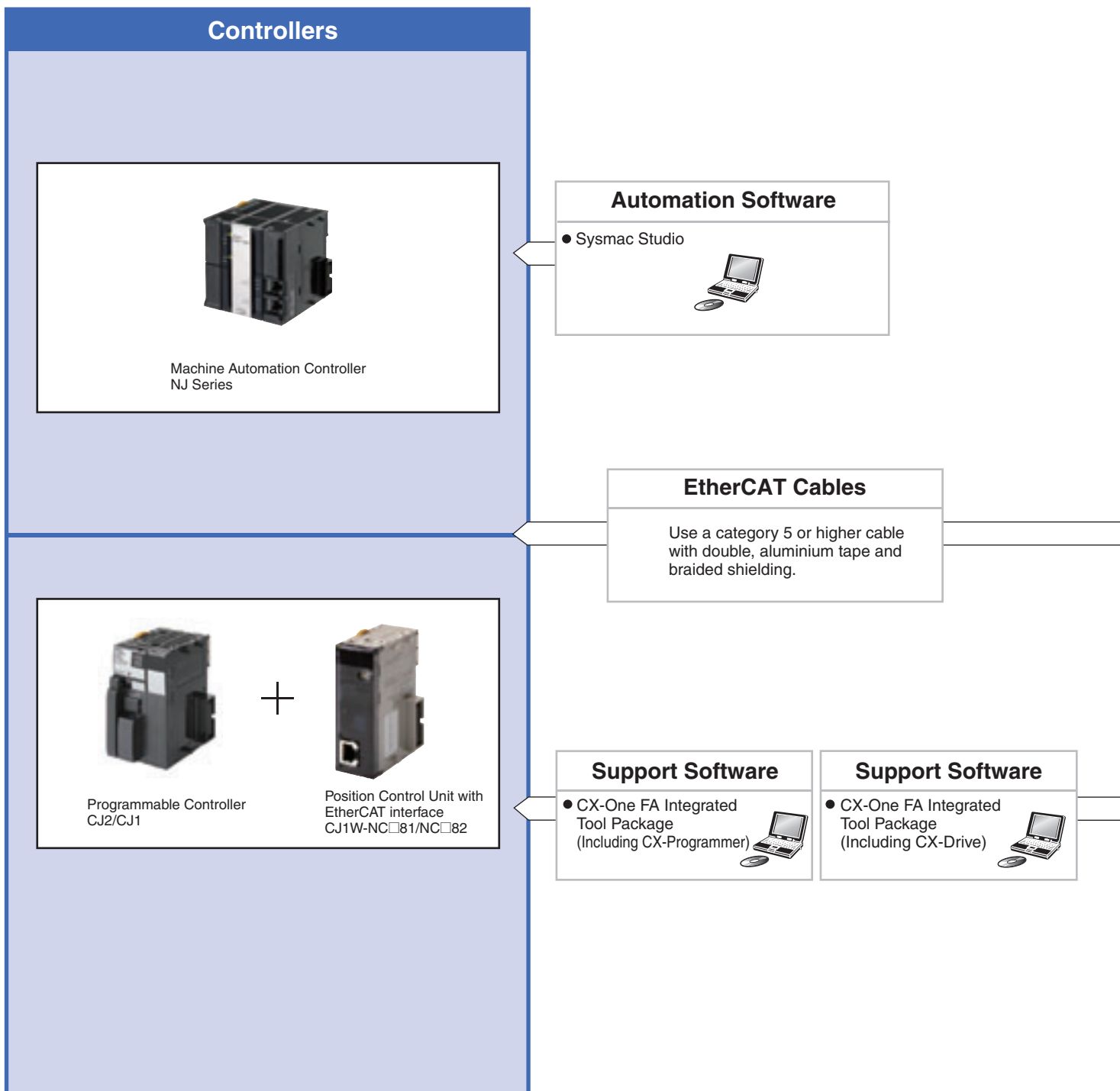

High-Speed and High-Precision G5 Series EtherCAT Communications with the Controller



- High-accuracy positioning with fully-closed control.
- Servo Drives for 400VAC globally widens applicable systems and environment, including large-scale equipment.
- Safe design and Safe Torque Off (STO) function.
- Vibration can be suppressed in acceleration/deceleration even in low-rigidity mechanical systems.



Ro

G5-Series
System Configuration

EtherCAT Communications
AC Servo Drive

EtherCAT Communications
Linear Motor Type
AC Servo Drive

General-purpose Inputs
AC Servo Drive

ML-II Type
AC Servo Drive

AC Servomotors

Linear Motor

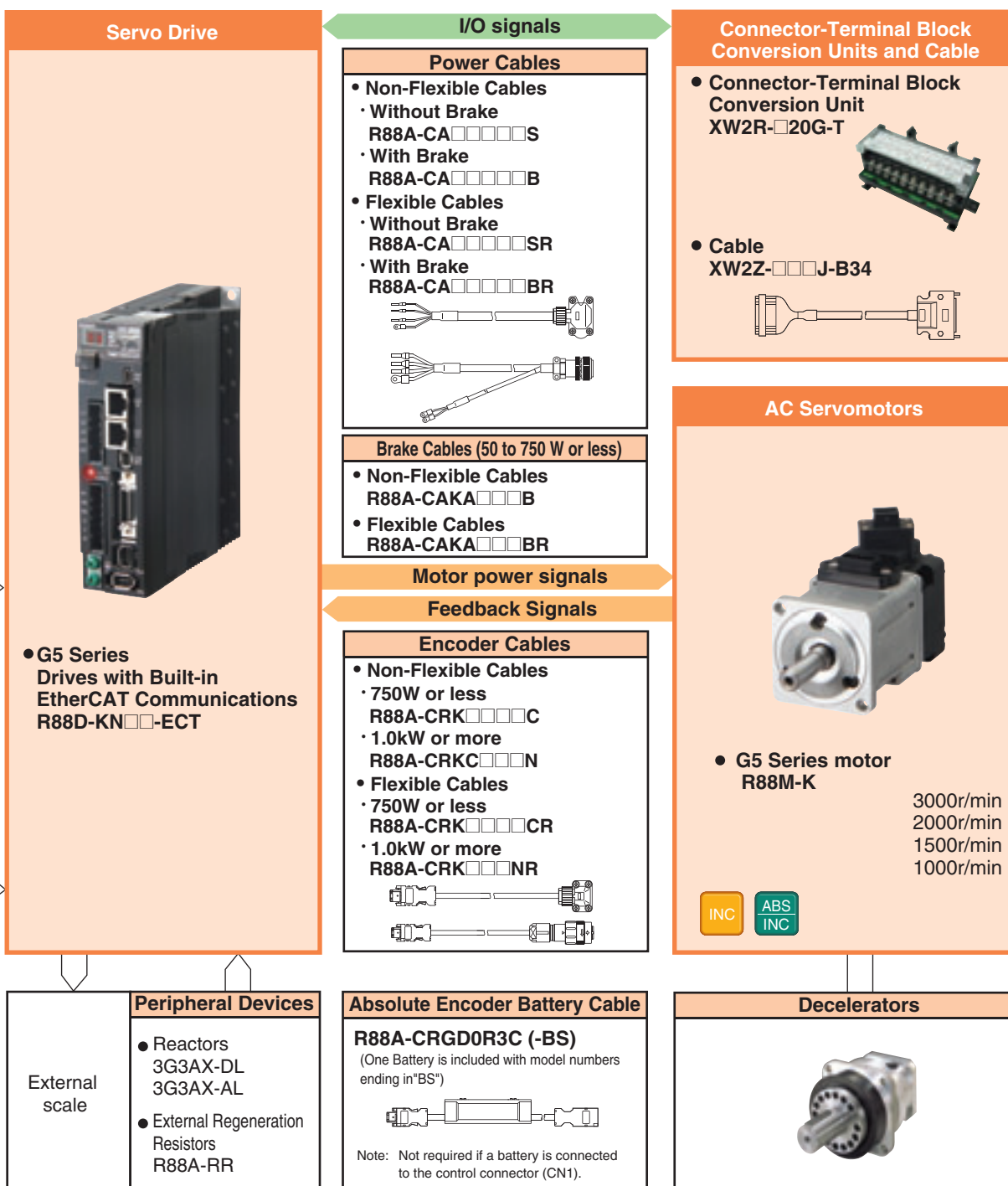

R88L-EC/R88D-KN□-ECT-L

System Configuration

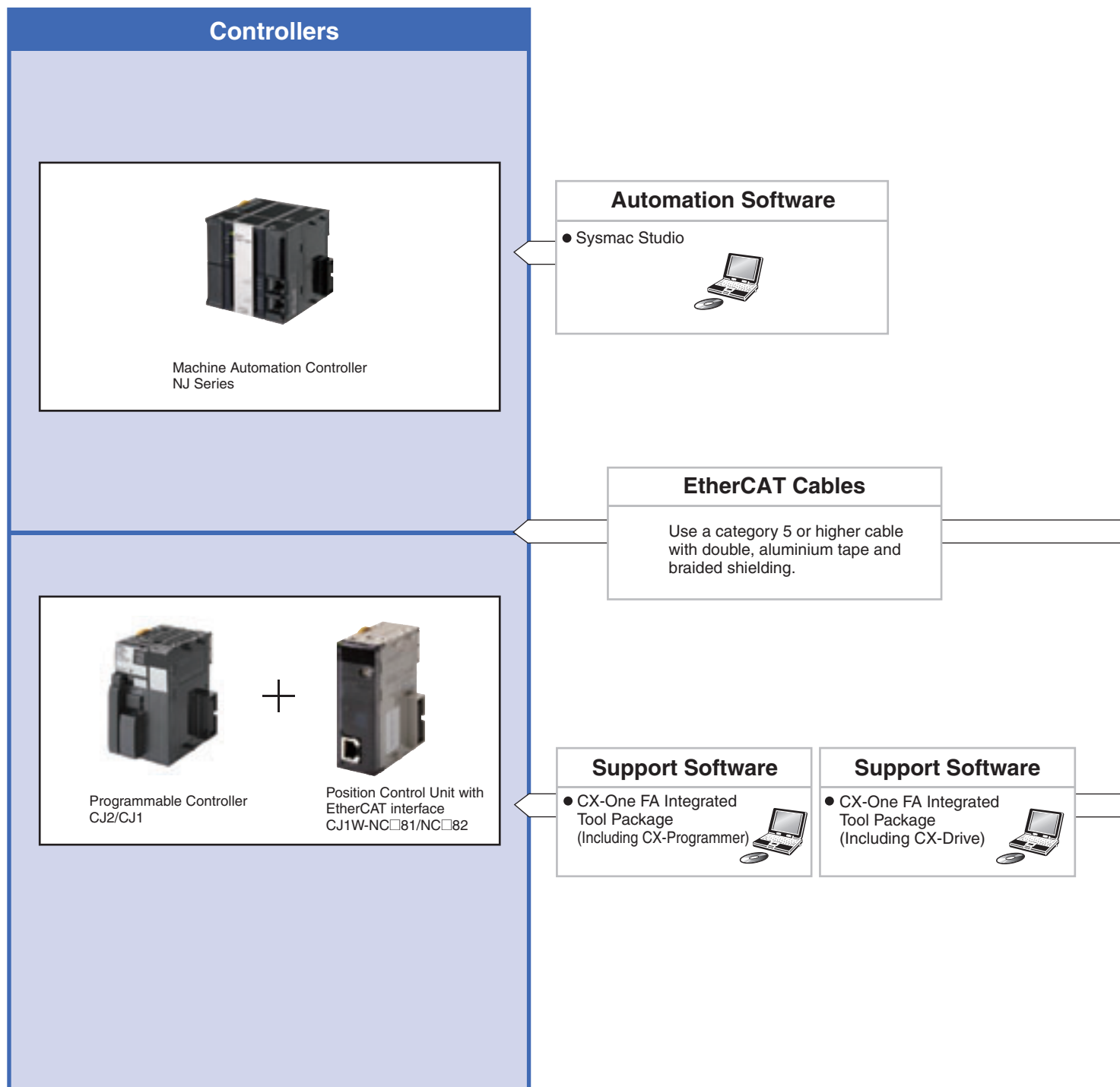

Linear Motor for Higher-speed and Higher-precision

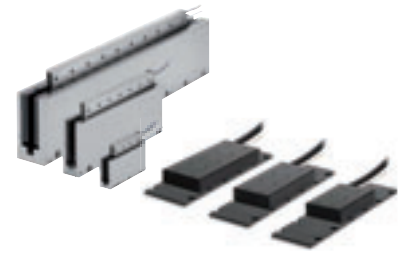

- Inherited functions and performance of G5 series and EtherCAT communications achieve high-speed and high-precision positioning.
- Lineup of compact and high-thrust iron-core motor type and cogging-free ironless motor type with excellent speed stability.
- Same Iron-core motor type for 200V AC and 400V AC.
- Quick setup by automatic setup function.

G5-Series
System Configuration

EtherCAT Communications
AC Servo Drive

EtherCAT Communications
Linear Motor Type
AC Servo Drive

General-purpose Inputs
AC Servo Drive

ML-II Type
AC Servo Drive

AC Servomotors

Linear Motor

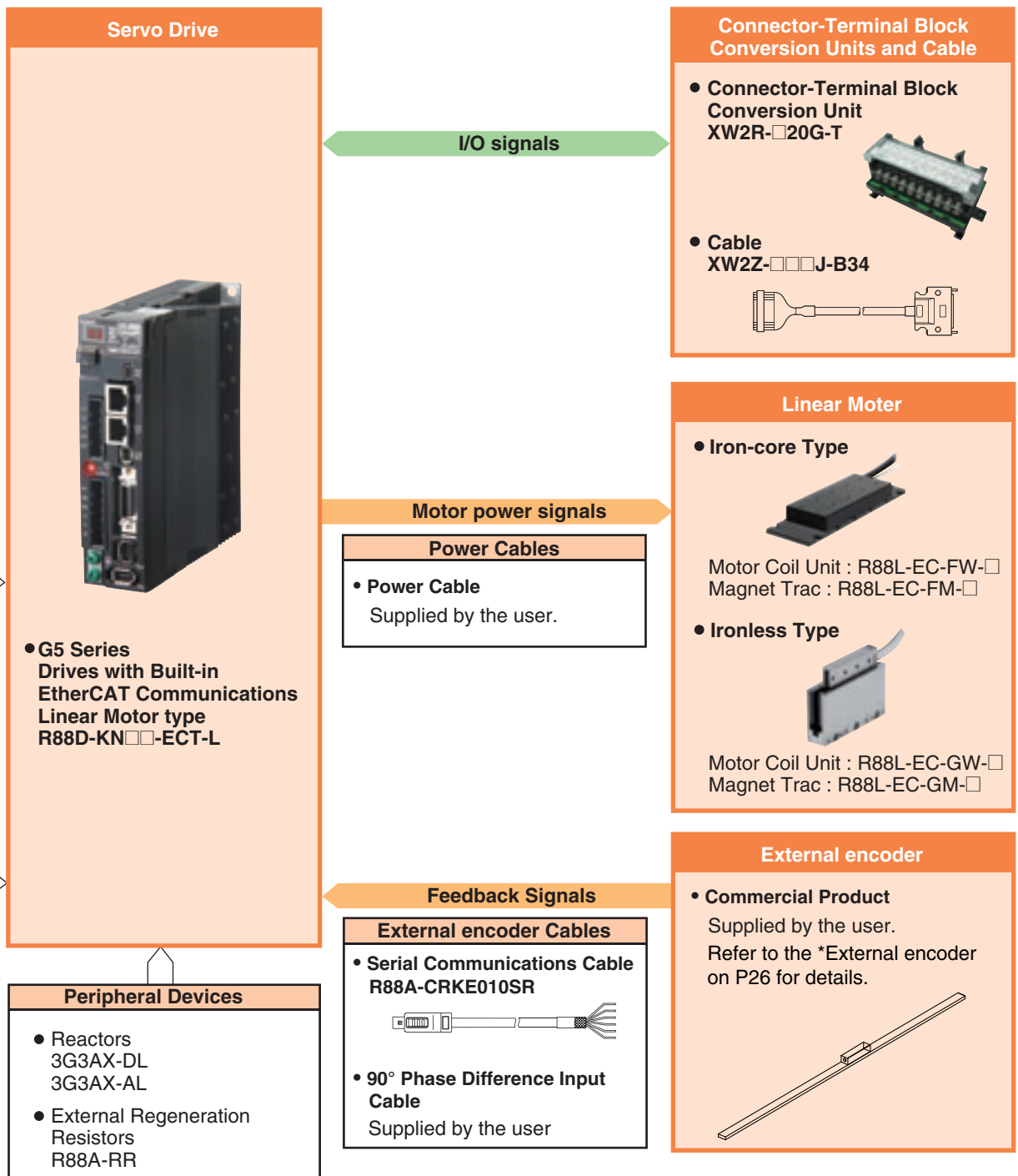

G5-series AC Servomotors/Servo Drives with General-purpose Pulse Train or Analog Inputs

R88M-K/R88D-KT

System Configuration

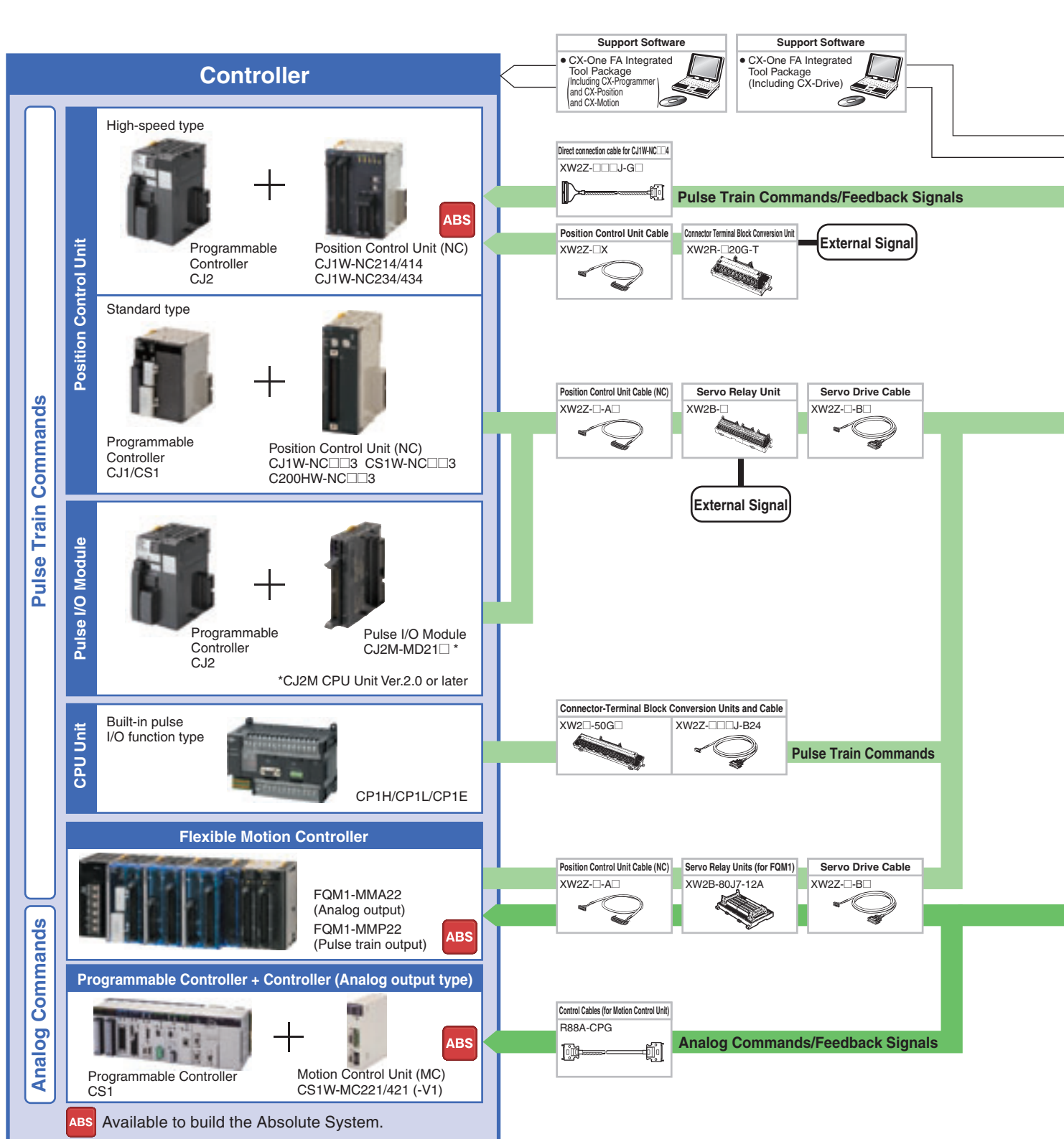

The Preeminent Servo That Revolutionizes Motion Control



- Industry Top-class Tracking Performance. Speed Response Frequency of 2 kHz.
- Best Positioning Accuracy*. Featuring a 20-bit high-resolution incremental encoder. * 8 times the resolution of previous OMRON models
- High-precision Positioning. Fully Closed Loop Control Is a Standard Feature.
- Conforms to the Latest International Standards. Safety and Productivity.
- Globalization. Lineup of 400 VAC Servomotors.

USB communications

Servo Drive



• G5 Series driver R88D-KT

100 VAC
200 VAC
400 VAC

Motor power signals

Power Cables

- Non-flexible Cables
 - Without Brake R88A-CA□□□□□S
 - With Brake R88A-CA□□□□□B
- Flexible Cables
 - Without Brake R88A-CA□□□□□SR
 - With Brake R88A-CA□□□□□BR

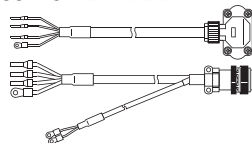

Brake Cables (50 to 750 W or less)

- Non-flexible Cables R88A-CAKA□□□□B
- Flexible Cables R88A-CAKA□□□□BR

Feedback Signals

Encoder Cables

- Non-Flexible Cables
 - 750W or less R88A-CRK□□□□□C
 - 1.0kW or more R88A-CRK□□□□□N
- Flexible Cables
 - 750W or less R88A-CRK□□□□□CR
 - 1.0kW or more R88A-CRK□□□□□NR

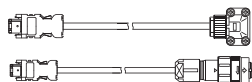

AC Servomotors



• G5 Series motor R88M-K

3,000 r/min
2,000 r/min
1,500 r/min
1,000 r/min



Peripheral Devices

External scale

- Reactors 3G3AX-DL 3G3AX-AL
- External Regeneration Resistors R88A-RR

Absolute Encoder Battery Cable

R88A-CRGD0R3C (-BS)
(One Battery is included with Servo Drivers with model numbers ending in "BS.")

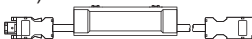

* Not required if a battery is connected to the control connector (CN1).

Decelerators



G5-Series System Configuration

EtherCAT Communications AC Servo Drive

EtherCAT Communications Linear Motor Type AC Servo Drive

General-purpose Inputs AC Servo Drive

ML-II Type AC Servo Drive

AC Servomotors

Linear Motor

R88M-K/R88D-KN□-ML2

System Configuration

Controllers (MECHATROLINK-II type)

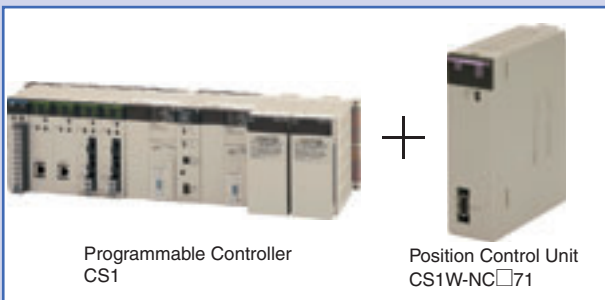
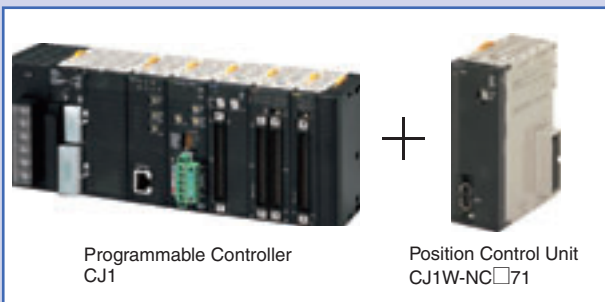

Support Software

- CX-One FA Integrated Tool Package (Including CX-Programmer and CX-Position and CX-Motion)

Support Software

- CX-One FA Integrated Tool Package (Including CX-Drive)

MECHATROLINK-II

MECHATROLINK-II Cables

(With ring core and USB connector on both ends)
FNY-W6003-□□ (OMRON model number)
 (Without ring core USB connector on both ends)
FNY-W6002-□□ (OMRON model number)

MECHATROLINK-II Repeater

		Maximum transmission distance	
		0 to 30 m	30 to 50 m
Number of connected devices	1 to 15	Repeater not required.	Repeater not required.
	16	Repeater not required.	Repeater required.



High-Speed and High-Precision G5 Series MECHATROLINK-II Communications with the Controller

- Data transfer using MECHATROLINK-II Communications:
All control data that can be interfaced between the Servo Driver and the Controller is transmitted using data communications. This enables maximizing the Servomotor performance without restricting the transmission performance of the control signals.
- Having a communications module built into the Servo Driver significantly saves space in the control panel.

G5-Series System Configuration
EtherCAT Communications AC Servo Drive
EtherCAT Communications Linear Motor Type AC Servo Drive
General-purpose Inputs AC Servo Drive
ML-II Type AC Servo Drive
AC Servomotors
Linear Motor

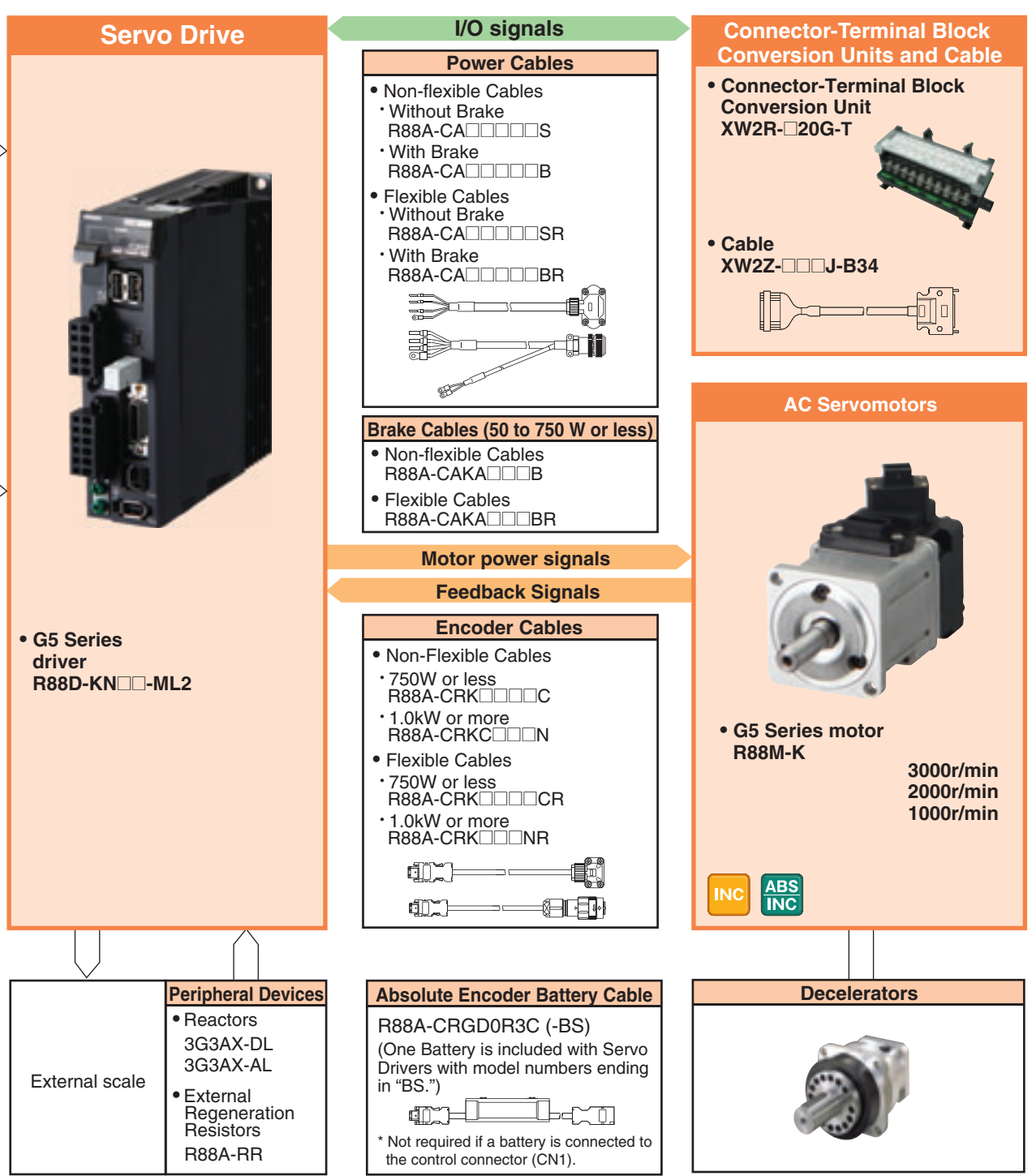

G5-series AC Servo Drives with Built-in EtherCAT Communications

R88D-KN□-ECT

Contents



- Ordering Information
- Specifications
 - General Specifications
 - Characteristics
 - Servo Drives with Single-phase 100 VAC Input Power
 - Servo Drives with Single-phase or Three-phase 200 VAC Input Power
 - Servo Drives with Three-phase 400 VAC Input Power
 - EtherCAT Communication Specifications
- Version Information
- Names and Functions
 - Servo Drive Part Names
 - Functions
- Dimensions

Ordering Information

Refer to the Ordering Information.

Specifications

General Specifications

Item		Specifications	
Ambient operating temperature and operating humidity		0 to 55°C, 90%RH max. (with no condensation)	
Storage ambient temperature and humidity		-20 to 65°C, 90%RH max. (with no condensation)	
Operating and storage atmosphere		No corrosive gases	
Vibration resistance		10 to 60 Hz and at an acceleration of 5.88 m/s ² or less (Not to be run continuously at a resonance point)	
Insulation resistance		Between power supply terminals/power terminals and FG terminal: 0.5 MΩ min. (at 500 VDC)	
Dielectric strength		Between power supply/power line terminals and FG terminal: 1,500 VAC for 1 min at 50/60 Hz	
Protective structure		Built into panel	
International standard	EC Directives	EMC Directive	EN 55011, EN 61000-6-2, IEC 61800-3
		Low Voltage Directive	EN 61800-5-1
		Machinery Directives	EN954-1 (Cat.3), EN ISO 13849-1: 2008 (Category 3) (PLc,d), ISO 13849-1: 2006 (Category 3) (PLc,d), EN61508 (SIL2), EN62061 (SIL2), EN61800-5-2 (STO), IEC61326-3-1 (SIL2)
	UL standards		UL 508C
	CSA standards		CSA22.2 No. 14
Korean Radio Regulations (KC)		Certified	

Note: 1. The above items reflect individual evaluation testing. The results may differ under compound conditions.

Note: 2. Always disconnect all connections to the Servo Drive before you perform insulation resistance tests on it. If you perform an insulation resistance test while the Servo Drive is connected, the Servo Drive may be damaged. Never perform dielectric strength tests on the Servo Drive. Failure to follow this precaution may result in damaging internal elements.

Note: 3. Some Servo Drive parts will require maintenance. For details, refer to the G5 series USER'S MANUAL. Confirm the Manual No. that is listed in Related Manuals.

Characteristics

● Servo Drives with 100 VAC Input Power for Single-phase input type

Item			R88D-KNA5L-ECT	R88D-KN01L-ECT	R88D-KN02L-ECT	R88D-KN04L-ECT
Continuous output current (rms)			1.2A	1.7A	2.5A	4.6A
Input power supply	Main circuit	Power supply capacity	0.4KVA	0.4KVA	0.5KVA	0.9KVA
		Power supply voltage	Single-phase 100 to 120 VAC (85 to 132 V) 50/60 Hz			
		Rated current	1.7A	2.6A	4.3A	7.6A
		Heat value*1	11W	16.6W	21W	25W
	Control circuit	Power supply voltage	Single-phase 100 to 120 VAC (85 to 132 V) 50/60 Hz			
		Heat value*1	4W	4W	4W	4W
Weight			Approx. 0.8kg	Approx. 0.8kg	Approx. 1.0kg	Approx. 1.6kg
Maximum applicable motor capacity			50W	100W	200W	400 W
Applicable Servomotor (R88M-)	3,000 r/min Servomotors	INC	K05030H	K10030L	K20030L	K40030L
		ABS	K05030T	K10030S	K20030S	K40030S
	2,000 r/min Servomotors	ABS	-	-	-	-
		ABS	-	-	-	-

*1. The heat value is given for rated operation.

● Servo Drives with 200 VAC Input Power for Single-phase/Three-phase input type

Item			R88D-KN01H-ECT	R88D-KN02H-ECT	R88D-KN04H-ECT	R88D-KN08H-ECT	R88D-KN10H-ECT	R88D-KN15H-ECT
Continuous output current (rms)			1.2A	1.6A	2.6A	4.1A	5.9A	9.4A
Input power supply	Main circuit	Power supply capacity	0.5KVA	0.5KVA *1	0.9KVA	1.3KVA	1.8KVA	2.3KVA
		Power supply voltage	Single-phase or 3-phase 200 to 240 VAC (170 to 264 V) 50/60 Hz					
		Rated current	1.6/0.9A *1	2.4/1.3A *1	4.1/2.4A *1	6.6/3.6A *1	9.1/5.2A *1	14.2/8.1A *1
		Heat value*2	14.3/13.7W*1	23/19W *1	33/24W *1	30/35.5W *1	57/49W *1	104/93W*1
	Control circuit	Power supply voltage	Single-phase 200 to 240 VAC (170 to 264 V) 50/60 Hz					
		Heat value*2	4W	4W	4W	4W	7W	7W
Weight			Approx. 0.8kg	Approx. 0.8kg	Approx. 1.0kg	Approx. 1.6kg	Approx. 1.8kg	Approx. 1.8kg
Maximum applicable motor capacity			100W	200W	400W	750W	1kW	1.5kW
Applicable Servomotor (R88M-)	3,000 r/min Servomotors	INC	K05030H K10030H	K20030H	K40030H	K75030H	-	K1K030H K1K530H
		ABS	K05030T K10030T	K20030T	K40030T	K75030T	-	K1K030T K1K530T
	2,000 r/min Servomotors	INC	-	-	-	-	K1K020H	K1K520H
		ABS	-	-	-	-	K1K020T	K1K520T
	1,000 r/min Servomotors	INC	-	-	-	-	-	K90010H
		ABS	-	-	-	-	-	K90010T

*1. The first value is for single-phase input power and the second value is for 3-phase input power.

*2. The heat value is given for rated operation.

AC Servomotor/Drive G5-series

● Servo Drives with 200 VAC Input Power for Three-phase input type

Item			R88D-KN20H-ECT	R88D-KN30H-ECT	R88D-KN50H-ECT	R88D-KN75H-ECT	R88D-KN150H-ECT	
Continuous output current (rms)			13.4A	18.7A	33.0A	44.0A	66.1A	
Input power supply	Main circuit	Power supply capacity	3.3KVA	4.5KVA	7.5KVA	11.0KVA	22.0KVA	
		Power supply voltage	3-phase 200 to 230 VAC (170 to 253 V) 50/60 Hz				3-phase 200 to 230 VAC (170 to 253V) 50/60Hz 280 to 325 VDC (238 to 357V)	
		Rated current	11.8A	15.1A	21.6A	32.0A	58.0A	
		Heat value *1	139W	108W	328W	381W	720W	
	Control circuit	Power supply voltage	Single-phase 200 to 230 VAC (170 to 253 V) 50/60 Hz				Single-phase 200 to 230 VAC (170 to 253V) 50/60Hz 280 to 325 VDC (238 to 357V)	
		Heat value *1	10W	13W	13W	15W	17W	
Weight			Approx. 2.7kg	Approx. 4.8kg	Approx. 4.8kg	Approx. 13.5kg	Approx. 21.0kg	
Maximum applicable motor capacity			2kW	3kW	5kW	7.5kW	15kW	
Applicable Servomotor (R88M-)	3,000 r/min Servomotors	INC	K2K030H	K3K030H	K4K030H K5K030H	-	-	
		ABS	K2K030T	K3K030T	K4K030T K5K030T	-	-	
	2,000 r/min, 1,500 r/min Servomotors	INC	K2K020H	K3K020H	K4K020H K5K020H	-	-	
		ABS	K2K020T	K3K020T	K4K020T K5K020T	K7K515T	K11K015T K15K015T	
	1,000 r/min Servomotors	INC	-	K2K010H	K3K010H	-	-	
		ABS	-	K2K010T	K3K010T K4K510T	K6K010T	-	

*1. The heat value is given for rated operation.

● Servo Drives with 400 VAC Input Power for Three-phase input type

Item			R88D-KN06F-ECT	R88D-KN10F-ECT	R88D-KN15F-ECT	R88D-KN20F-ECT	R88D-KN30F-ECT	R88D-KN50F-ECT	R88D-KN75F-ECT	R88D-KN150F-ECT	
Continuous output current (rms)			1.5A	2.9A	4.7A	6.7A	9.4A	16.5A	22.0A	33.1A	
Input power supply	Main circuit	Power supply capacity	1.2KVA	1.8KVA	2.3KVA	3.8KVA	4.5KVA	6.0KVA	11.0KVA	22.0KVA	
		Power supply voltage	3-phase 380 to 480 VAC (323 to 528 V) 50/60 Hz								
		Rated current	2.1A	2.8A	4.7A	5.9A	7.6A	12.1A	16.0A	29.0A	
		Heat value *1	32.2W	48W	49W	65W	108W	200W	300W	590W	
	Control circuit	Power supply voltage	24 VDC (20.4 to 27.6 V)								
		Heat value *1	7W	7W	7W	10W	13W	13W	15W	22W	
Weight			Approx. 1.9kg	Approx. 1.9kg	Approx. 1.9kg	Approx. 2.7kg	Approx. 4.7kg	Approx. 4.7kg	Approx. 13.5kg	Approx. 21.0kg	
Maximum applicable motor capacity			600W	1kW	1.5kW	2kW	3kW	5kW	7.5kW	15kW	
Applicable Servomotor (R88M-)	3,000 r/min Servomotors	INC	-	K75030F	K1K030F K1K530F	K2K030F	K3K030F	K4K030F K5K030F	-	-	
		ABS	-	K75030C	K1K030C K1K530C	K2K030C	K3K030C	K4K030C K5K030C	-	-	
	2,000 r/min, 1,500 r/min Servomotors	INC	K40020F K60020F	K1K020F	K1K520F	K2K020F	K3K020F	K4K020F K5K020F	-	-	
		ABS	K40020C K60020C	K1K020C	K1K520C	K2K020C	K3K020C	K4K020C K5K020C	K7K515C	K11K015C K15K015C	
	1,000 r/min Servomotors	INC	-	-	K90010F	-	K2K010F	K3K010F	-	-	
			-	-	K90010C	-	K2K010C	K3K010C K4K510C	K6K010C	-	

*1. The heat value is given for rated operation.

EtherCAT Communications Specifications

Item	Specification
Communications standard	IEC 61158 Type 12, IEC 61800-7 CiA 402 Drive Profile
Physical layer	100BASE-TX (IEEE802.3)
Connectors	RJ45 × 2 (shielded) ECAT IN: EtherCAT input ECAT OUT: EtherCAT output
Communications media	Ethernet Category 5 (100BASE-TX) or higher (twisted-pair cable with double, aluminum tape and braided shielding) is recommended.
Communications distance	Distance between nodes: 100 m max.
Process data	Fixed PDO mapping
Mailbox (CoE)	Emergency messages, SDO requests, SDO responses, and SDO information
Distributed clock (DC)	Synchronization in DC mode. DC cycle: 250 μs, 500 μs, 1 ms, 2 ms, 4 ms
LED indicators	L/A IN (Link/Activity IN) × 1 L/A OUT (Link/Activity OUT) × 1 RUN × 1 ERR × 1
CiA402 Drive Profile	<ul style="list-style-type: none"> • Cyclic synchronous position mode • Cyclic synchronous velocity mode • Cyclic synchronous torque mode • Profile position mode • Homing mode • Touch probe function (Latch function) • Torque limit function

Version Information

Unit Versions

Unit	Model	Unit version		
		Unit version 1.0	Unit version 2.0	Unit version 2.1
AC Servo Drives G5-Series built-in EtherCAT Communications	R88D-KN□-ECT-R	Supported		
	R88D-KN□-ECT		Supported	Supported
Compatible Sysmac Studio version		Version 1.00 or higher *1	Version 1.00 or higher *2	Version 1.00 or higher
Compatible CX-Drive version		Version 2.2 or higher	Version 2.3 or higher	Version 2.4 or higher

*1. The function that was enhanced by the upgrade for Unit version 2.0 can not be used. For detail, refer to "Function Support by Unit Version".

*2. The function that was enhanced by the upgrade for Unit version 2.1 can not be used. For detail, refer to "Function Support by Unit Version".

Function Support by Unit Version

Unit		AC Servo Drives G5-Series built-in EtherCAT Communications		
Model		R88D-KN□-ECT-R	R88D-KN□-ECT	
Unit version		Unit version 1.0	Unit version 2.0	Unit version 2.1
Sysmac Products Features	Sysmac Error Status	No supported		Supported
	Saving the Node Address Setting	No supported		Supported
	Serial Number Display *1	No supported		Supported
	ESI Specification (Version 1.0)	No supported		Supported
	SII Data Check	No supported		Supported
Fixed PDO mapping		No supported	Supported	
Variable PDO mapping (1600 hex, 1A00 hex)		No supported		Supported
Available operation modes	csp: Cyclic synchronous position mode	Supported		
	csv: Cyclic synchronous velocity mode	No supported	Supported	
	cst: Cyclic synchronous torque mode	No supported	Supported	
	pp: Profile position mode	No supported		Supported
	hm: Homing mode	No supported	Supported	
FIR filter function		No supported	Supported*2 (Available when the communications cycle is 1 ms or above)	
Error detection function	Excessive Speed Deviation Error	No supported	Supported	
	Interruptions Error	No supported	Supported	
Electronic gear function		Supported	No supported*3 (only to 1:1)	Supported

AC Servomotor/Drive G5-series

Unit		AC Servo Drives G5-Series built-in EtherCAT Communications		
Model		R88D-KN□-ECT-R	R88D-KN□-ECT	
Unit version		Unit version 1.0	Unit version 2.0	Unit version 2.1
Item				
Fully-closed Control *4		Supported	Available when the communications cycle is 500 μs or above in csp and 1 ms or above in hm.	Available when the communications cycle is 1 ms or above at an electronic gear ratio of 1:1 and 2 ms or above at a gear ratio other than 1:1.*5
Torque limit objects		PDO mapping to 60E0/60E1 hex is not possible.	PDO mapping to 60E0/60E1 hex is possible.*6	
Positioning Completion Range		No supported		Supported
Reference Position for CSP (4020 hex)		No supported		Supported
Data Setting Warning Detection Setting (3781)		No supported		Supported*7
Version indication on the unit label		No supported	Supported	

*1. The function to show the serial number controlled by OMRON in 1018h-04 hex.

*2. Setting the communications cycle to 500 μs or less does not enable the FIR filter function, although doing so does not cause any error.

*3. Setting this to an electronic gear ratio other than 1:1 simply causes the G5-series AC Servo Drive to operate at 1:1 without any errors.

*4. If Fully-closed Control is not available, a Function Setting Error (Error No. 93.4) will occur.

*5. This is applicable only when the total size of the objects mapped to RxPDO is 12 bytes or less. For details, refer to the USER'S MANUAL.

*6. There are objects added (3013 hex/3522 hex) to or renamed (3525 hex/3526 hex) from unit version 1.0.

For details of these objects, refer to Torque Limit Selection (3521 hex) in Extended Objects of each manual.

*7. Only the following Servo Drive models support DC power input:

- R88D-KN75H-ECT • R88D-KN150H-ECT

Components and Functions

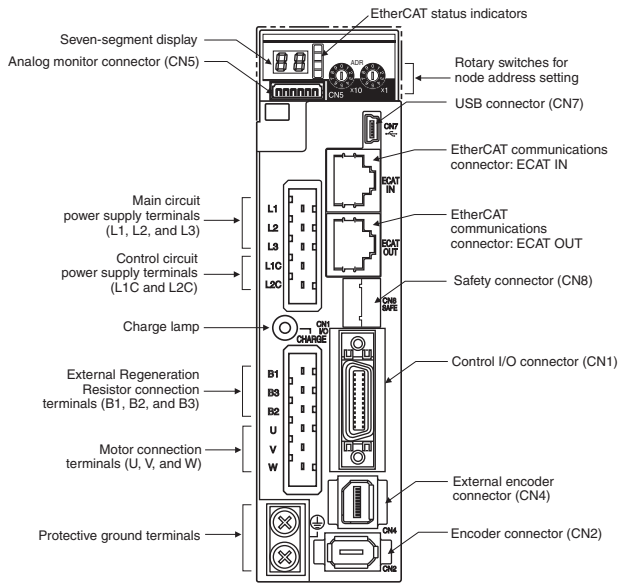

Display

A 2-digit 7-segment display shows the node address, error codes, and other Servo Drive status.

Charge Lamp

Lights when the main circuit power supply is turned ON.

EtherCAT Status Indicators

These indicators show the status of EtherCAT communications. For details, refer to the G5 series USER'S MANUAL (Cat.No.I576).

Control I/O Connector (CN1)

Used for command input signals and I/O signals.

Encoder Connector (CN2)

Connector for the encoder installed in the Servomotor.

External Encoder Connector (CN4)*

Connector for an encoder signal used during fully-closed control.

EtherCAT Communications Connectors (ECAT IN and ECAT OUT)

These connectors are for EtherCAT communications.

Analog Monitor Connector (CN5)

You can use a special cable to monitor values, such as the motor rotation speed, torque command value, etc.

USB Connector (CN7)

Communications connector for the computer.

Safety Connector (CN8)

Connector for safety devices.

If no safety devices are used, keep the factory-set safety bypass connector installed.

AC Servomotor/Drive G5-series

*External Encoder

Contact the encoder manufacturer to find out the detailed specifications such as operating environment before use.

External encoder type	Maker	Example of External encoder	Supported speed *1	Resolution *4 [μm]	Maximum speed *4 [m/s]
90° phase difference output type *2*3	–	Phase A/B type	0 to 4 Mpps (Multiplication \times 4)	–	–
Serial communications type (Incremental type) *3	Magnescale Co., Ltd	SR75	0 to 400 Mpps	0.01 to 1	3.3
		SR85		0.01 to 1	3.3
		SL700+PL101RP/RHP		0.1	10
		SL710+PL101RP/RHP		0.1	10
Serial communications type (Absolute type) *3	Mitutoyo Corporation	AT573A	0 to 400 Mpps	0.05	2.5
		ST778A(L)		0.1	5
	Magnescale Co., Ltd	SR77		0.01 to 1	3.3
		SR87		0.01 to 1	3.3
	Renishaw Co.	RESOLUTE		0.001	0.4
				0.05	20
	FAGOR AUTOMATION	SAP/SVAP/GAP LAP		0.1	40
				0.05	2.5
				0.1	2

*1. The supported speed is the internal feedback pulse speed [external encoder pulse/s] of the external encoder that can be processed by the Servo Drive.

Check the instruction manual of the external encoder for the speed range supported by your external encoder.

*2. These are the directions that the Drive counts a 90° phase difference output.

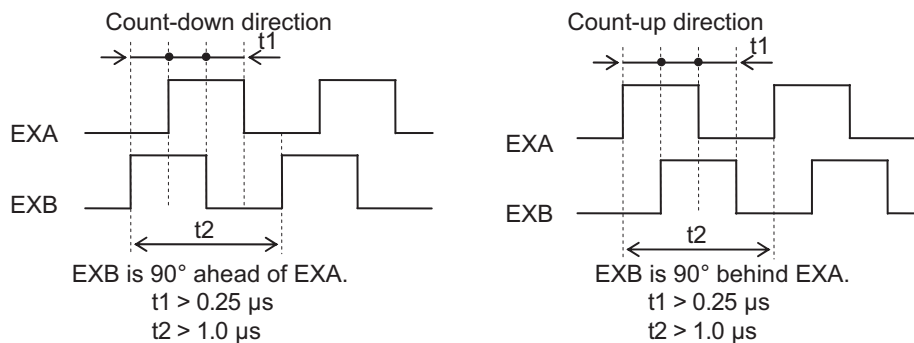

*3. For the external encoder connection direction, set the direction so that count-up occurs when the motor shaft is rotating counterclockwise, and count-down occurs when the motor shaft is rotating clockwise. If the connection direction cannot be selected due to installation conditions or any other reason, the count direction can be reversed using External Feedback Pulse Direction Switching (3326 hex).

*4. The resolution and maximum speed are the values for the G5-series Servo Drive. The resolution and maximum speed may be different from the specifications of the feedback encoder due to restriction on the maximum pulse frequency of the Servo Drive.

Dimensions

<Wall Mounting>

Single-phase 100 VAC R88D-KNA5L-ECT/-KN01L-ECT (50 to 100 W)
R88D-KN01L-ECT-L (100 W)

Single-phase/Three-phase 200 VAC R88D-KN01H-ECT/-KN02H-ECT (100 to 200 W)
R88D-KN01H-ECT-L/-KN02H-ECT-L (100 to 200 W)

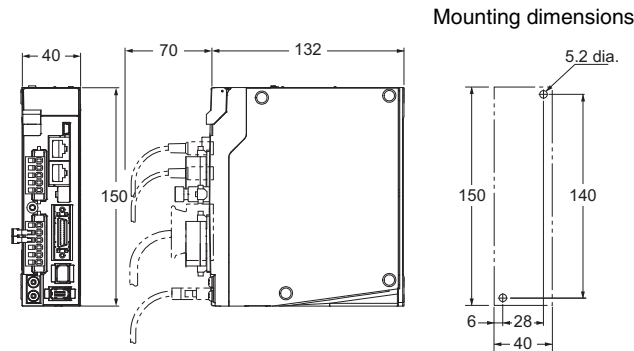

Single-phase 100 VAC R88D-KN02L-ECT (200 W)
R88D-KN02L-ECT-L (200 W)

Single-phase/Three-phase 200 VAC R88D-KN04H-ECT (400 W)
R88D-KN04H-ECT-L (400 W)

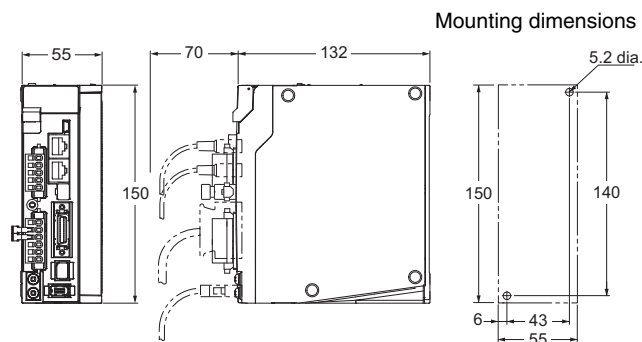

Single-phase 100 VAC R88D-KN04L-ECT (400 W)
R88D-KN04L-ECT-L (400 W)

Single-phase/Three-phase 200 VAC R88D-KN08H-ECT (750 W)
R88D-KN08H-ECT-L (750 W)

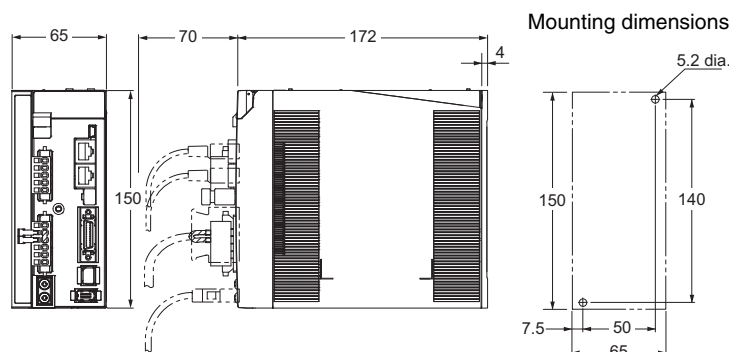

Note: R88D-KN□-ECT-L is the AC Servo Drives with Built-in EtherCAT Communications type.

Single-phase/Three-phase 200 VAC R88D-KN10H-ECT/-KN15H-ECT (900 W to 1.5 kW)
R88D-KN10H-ECT-L/-KN15H-ECT-L (1 kW to 1.5 kW)

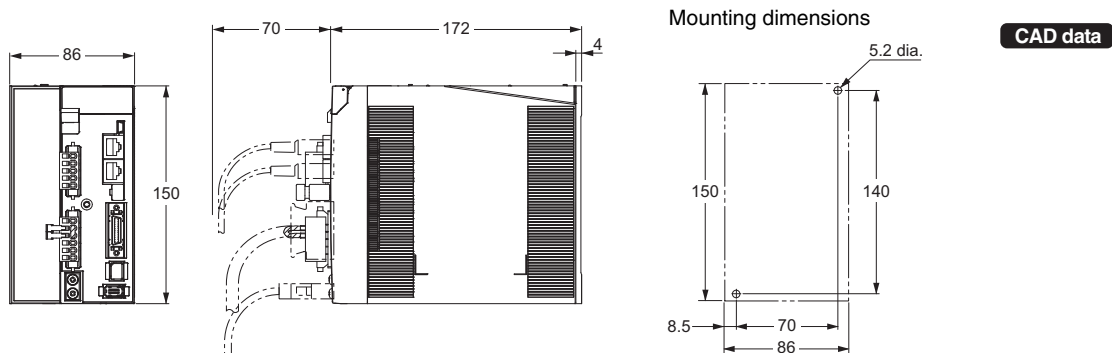

Three-phase 200 VAC R88D-KN20H-ECT (2 kW)

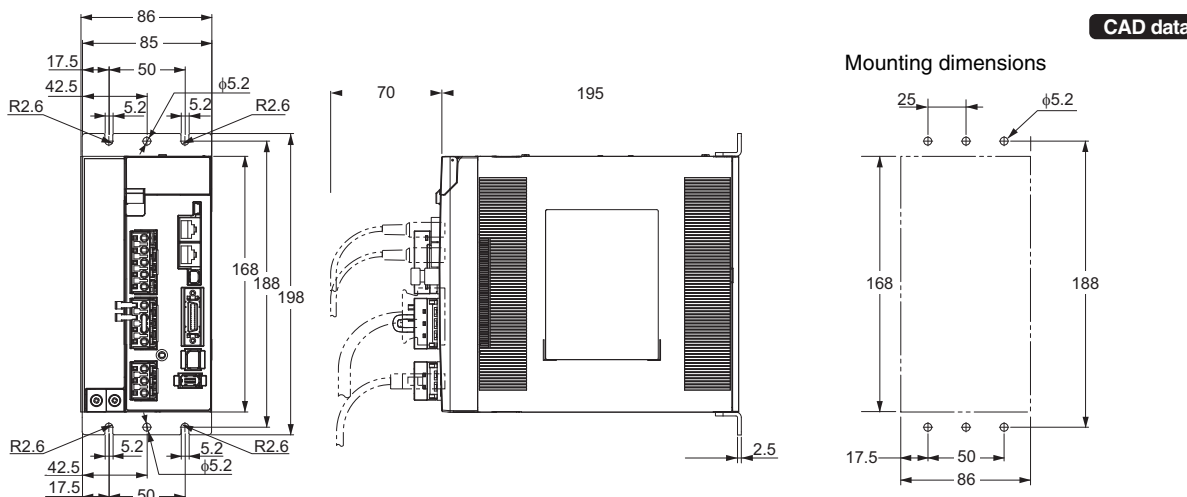

Three-phase 200 VAC R88D-KN30H-ECT/-KN50H-ECT (3 to 5 kW)

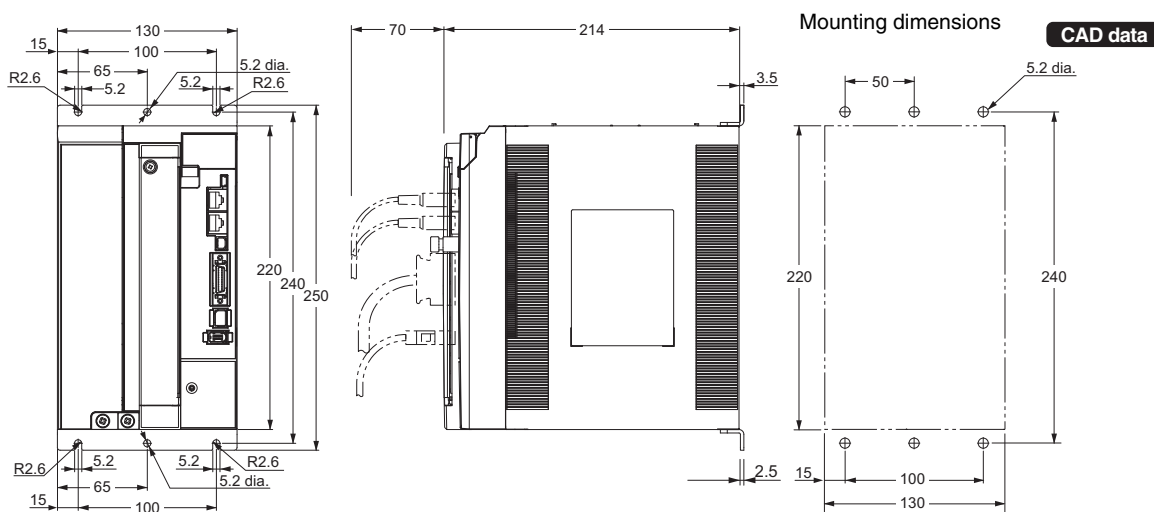

Three-phase 200 VAC R88D-KN75H-ECT (7.5 kW)

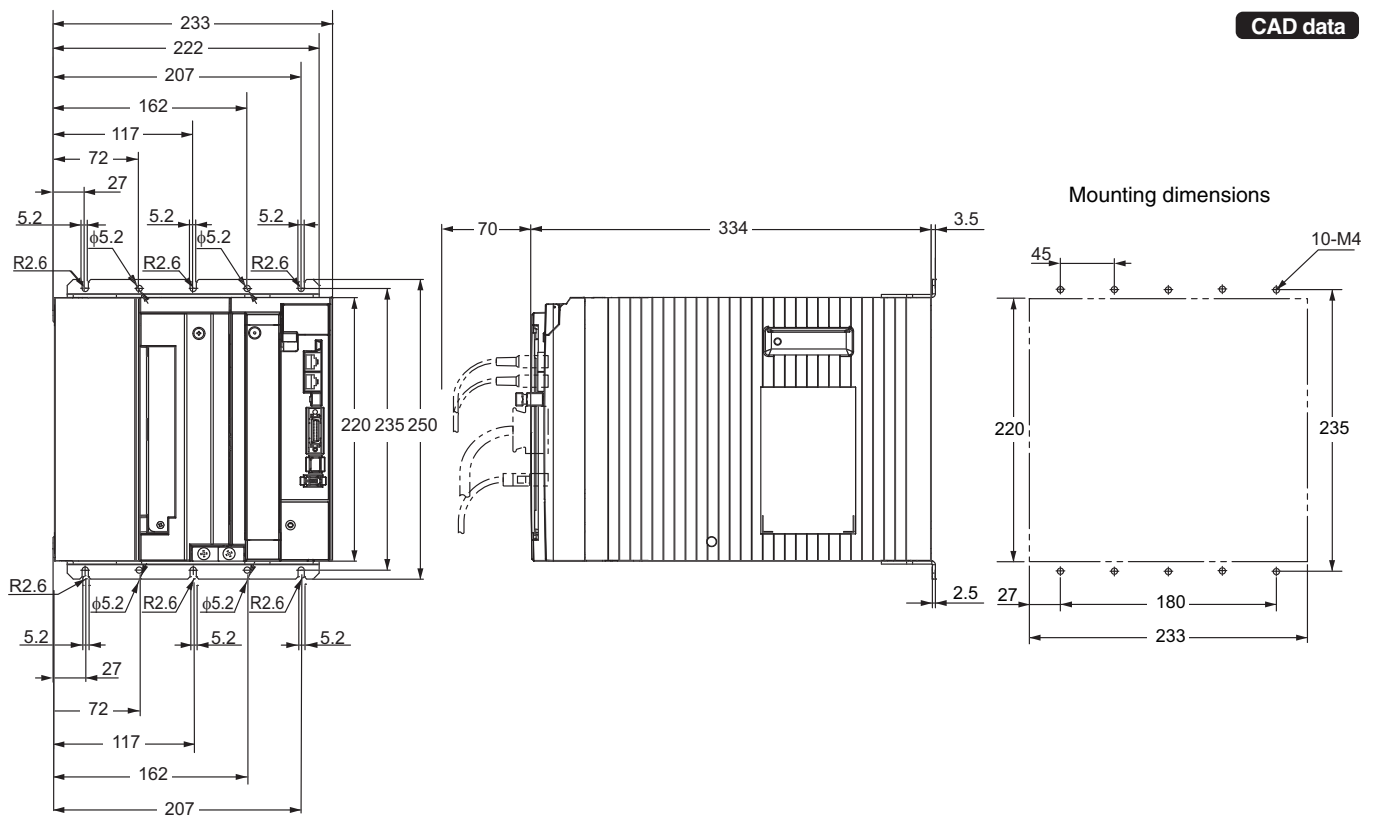

Three-phase 200 VAC R88D-KN150H-ECT (15 kW)

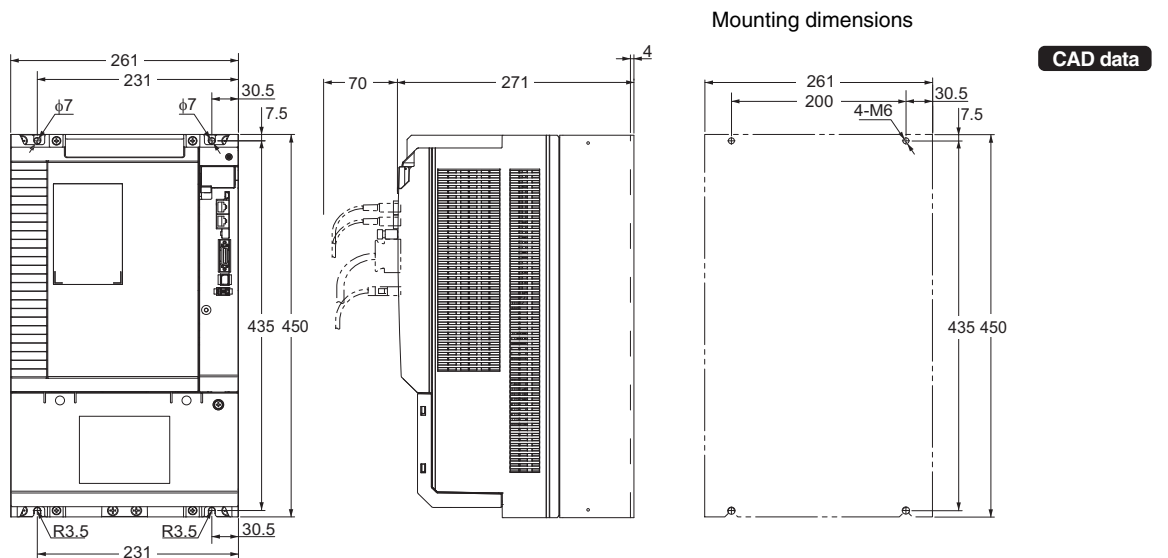

G5-Series
System Configuration

EtherCAT Communications
AC Servo Drive

EtherCAT Communications
Linear Motor Type
AC Servo Drive

General-purpose Inputs
AC Servo Drive

ML-II Type
AC Servo Drive

AC Servomotors

Linear Motor

Three-phase 400 VAC R88D-KN06F-ECT/-KN10F-ECT (600 W to 1.0 kW)
R88D-KN06F-ECT-L/-KN10F-ECT-L (600 W to 1.0 kW)
Three-phase 400 VAC R88D-KN15F-ECT (1.5 kW)
R88D-KN15F-ECT-L (1.5 kW)

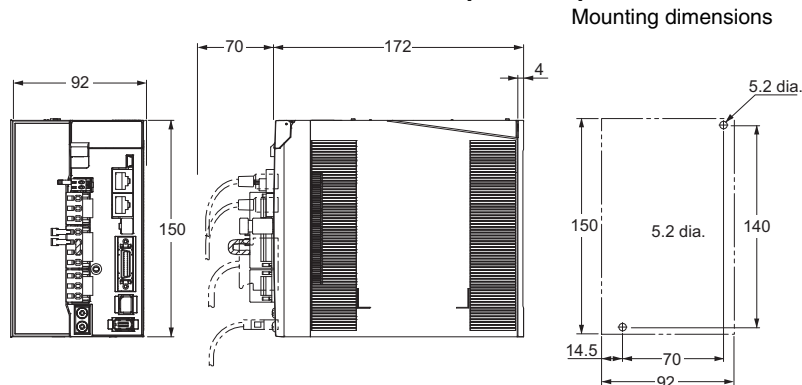

CAD data

Three-phase 400 VAC R88D-KN20F-ECT (2 kW)
R88D-KN20F-ECT-L (2 kW)

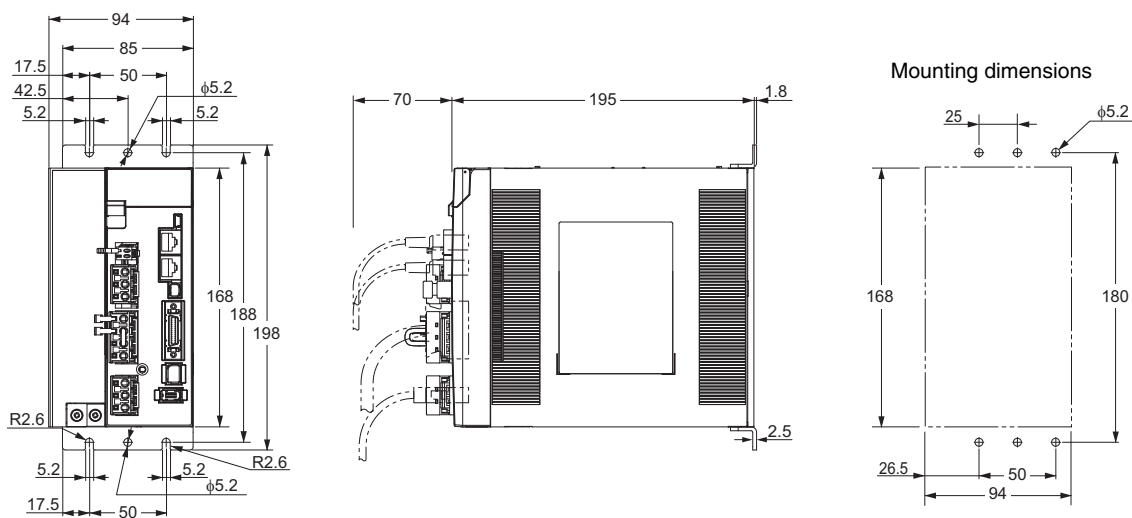

CAD data

Three-phase 400 VAC R88D-KN30F-ECT/-KN50F-ECT (3 to 5 kW)
R88D-KN30F-ECT-L (3 kW)

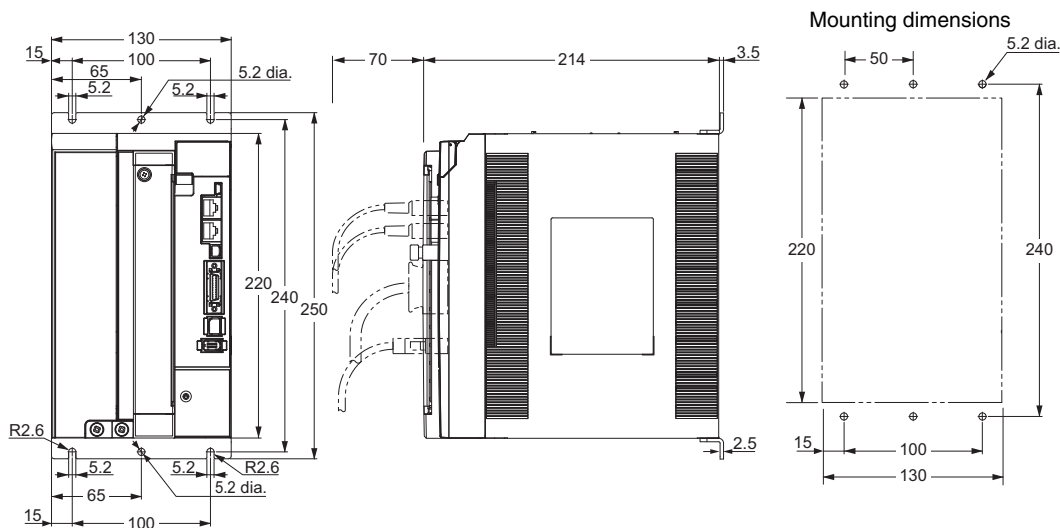

CAD data

Three-phase 200 VAC R88D-KN75H-ECT (7.5 kW)

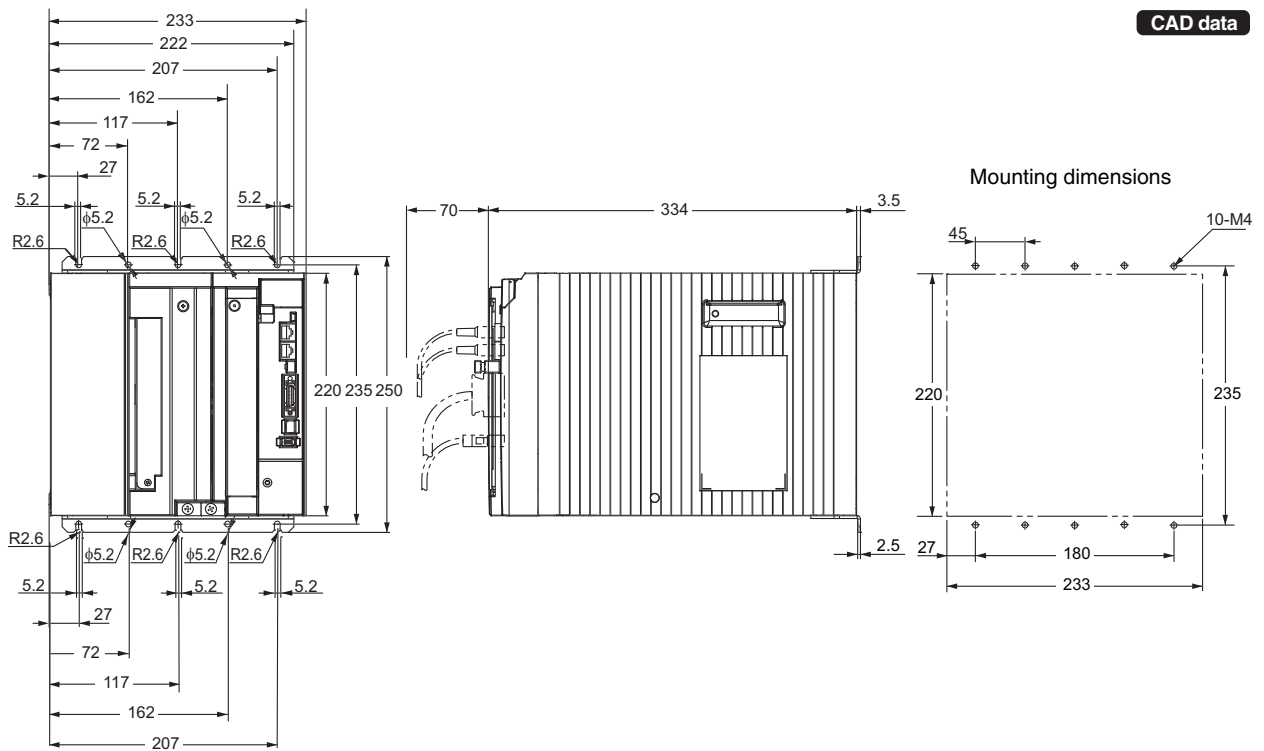

Three-phase 400 VAC R88D-KN150F-ECT (15kW)

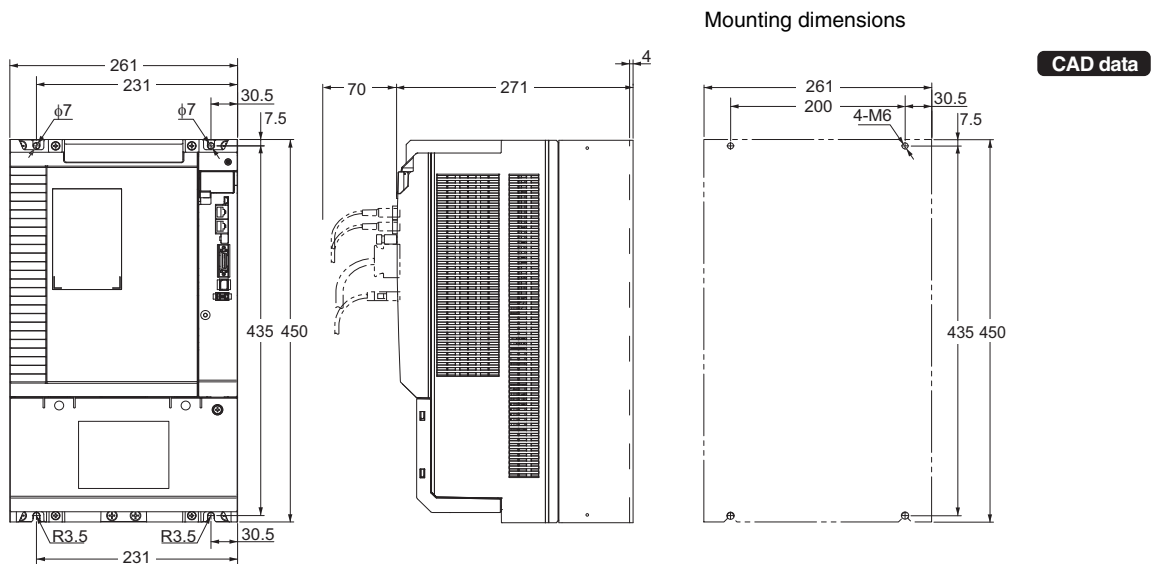

G5-Series
System Configuration

EtherCAT Communications
AC Servo Drive

EtherCAT Communications
Linear Motor Type
AC Servo Drive

General-purpose Inputs
AC Servo Drive

ML-II Type
AC Servo Drive

AC Servomotors

Linear Motor

G5-series AC Servo Drives with Built-in EtherCAT Communications Linear Motor Type

R88D-KN□-ECT-L

Contents



- Ordering Information
- Specifications
 - General Specifications
 - Characteristics
 - Servo Drives with 100 VAC Input Power
 - Servo Drives with 200 VAC Input Power
 - Servo Drives with 400 VAC Input Power
 - EtherCAT Communication Specifications
- Version Information
- Names and Functions
 - Servo Drive Part Names
 - Functions
- Dimensions

Ordering Information

Refer to the Ordering Information.

Specifications

General Specifications

Item	Specifications	
Ambient operating temperature and humidity	0 to 55°C, 20% to 85% max. (with no condensation)	
Storage ambient temperature and humidity	-20 to 65°C, 20% to 85% max. (with no condensation)	
Operating and storage atmosphere	No corrosive gases	
Vibration resistance	10 to 60 Hz and at an acceleration of 5.88 m/s ² or less (Not to be run continuously at the resonance point)	
Insulation resistance	Between power supply terminals/power terminals and FG terminal: 0.5 MΩ min. (at 500 VDC)	
Dielectric strength	Between power supply/power terminals and FG terminal: 1,500 VAC for 1 min at 50/60 Hz	
Protective structure	Built into panel	
EC Directives*	EMC Directive	EN 55011, EN 61000-6-2, EN 61800-3
	Low Voltage Directive	EN 61800-5-1
	Machinery Directives	EN954-1(Cat.3), EN ISO13849-1 (Cat.3)(PLc, d), ISO13849-1(Cat.3)(PLc, d), EN61508(SIL2), EN62061(SIL2), EN61800-5-2 (STO), IEC61326-3-1 (SIL 2)
UL standards	UL 508C	
CSA standards	CSA22.2 No.14	
Korean Radio Regulations (KC)	Certified	

* The certification from third party is issued in combination with the revolution type motor. The conformance as the whole system should be checked by machine builder.

- Note: 1.** The above items reflect individual evaluation testing. The results may differ under compound conditions.
- Note: 2.** Always disconnect all connections to the Servo Drive before you perform insulation resistance tests on it. If you perform an insulation resistance test while the Servo Drive is connected, the Servo Drive may be damaged. Never perform dielectric strength tests on the Servo Drive. Failure to follow this precaution may result in damaging internal elements.
- Note: 3.** Some Servo Drive parts will require maintenance. For details, refer to the G5 series USER'S MANUAL. Confirm the Manual No. that is listed in Related Manuals.
- Note: 4.** Vibration, unstable movement, or acoustic noise may occur by an exogenous noise. In such case, please reduce incoming noise as referred in G5 series user's manuals.

Characteristics

● 100-VAC Input Models for Single-phase input type

Item		R88D-KN01L-ECT-L	R88D-KN02L-ECT-L	R88D-KN04L-ECT-L	
Input power supply	Main circuit	Power supply capacity	0.4 KVA	0.5 KVA	0.9 KVA
		Power supply voltage	Single-phase 100 to 120 VAC (85 to 132 VAC) 50/60 Hz		
		Rated current	2.6 A	4.3 A	7.6 A
		Heat value ^{*1}	16.6 W	21 W	25 W
	Control circuit	Power supply voltage	Single-phase 100 to 120 VAC (85 to 132 VAC) 50/60 Hz		
		Heat value ^{*1}	4 W	4 W	4 W
Mass		Approx. 0.8 kg	Approx. 1.0 kg	Approx. 1.6 kg	
Maximum motor capacity	Motor Rated Rms Current	1.7 Arms	2.5 Arms	4.6 Arms	
	Maximum current of motor	5.1 Arms	7.5 Arms	13.8 Arms	

*1. The heat value is given for rated operation.

● 200-VAC Input Models for Single-phase/Three-phase input type

Item		R88D-KN01H-ECT-L	R88D-KN02H-ECT-L	R88D-KN04H-ECT-L	R88D-KN08H-ECT-L	R88D-KN10H-ECT-L	R88D-KN15H-ECT-L	
Input power supply	Main circuit	Power supply capacity	0.5 KVA	0.5 KVA	0.9 KVA	1.3 KVA	1.8 KVA	2.3 KVA
		Power supply voltage	Single-phase or 3-phase 200 to 240 VAC (170 to 264 VAC) 50/60 Hz					
		Rated current	1.6/0.9 A ^{*1}	2.4/1.3 A ^{*1}	4.1/2.4 A ^{*1}	6.6/3.6 A ^{*1}	9.1/5.2 A ^{*1}	14.2/8.1 A ^{*1}
		Heat value ^{*2}	14.3/13.7 W ^{*1}	23/19 W ^{*1}	33/24 W ^{*1}	30/35.5 W ^{*1}	57/49 W ^{*1}	104/93 W ^{*1}
	Control circuit	Power supply voltage	Single-phase 200 to 240 VAC (170 to 264 VAC) 50/60 Hz					
		Heat value ^{*2}	4 W	4 W	4 W	4 W	7 W	7 W
Mass		Approx. 0.8 kg	Approx. 0.8 kg	Approx. 1.0 kg	Approx. 1.6 kg	Approx. 1.8 kg	Approx. 1.8 kg	
Maximum motor capacity	Rated effective current of motor	1.2 Arms	1.6 Arms	2.6 Arms	4.1 Arms	5.9 Arms	9.4 Arms	
	Maximum current of motor	3.6 Arms	4.8 Arms	7.8 Arms	12.3 Arms	16.9 Arms	28.2 Arms	

*1. The first value is for single-phase input power and the second value is for 3-phase input power.

*2. The heat value is given for rated operation.

● 400-VAC Input Models for Three-phase input type

Item		R88D-KN06F-ECT-L	R88D-KN10F-ECT-L	R88D-KN15F-ECT-L	R88D-KN20F-ECT-L	R88D-KN30F-ECT-L	
Input power supply	Main circuit	Power supply capacity	1.2 KVA	1.8 KVA	2.3 KVA	3.8 KVA	4.5 KVA
		Power supply voltage	3-phase 380 to 480 VAC (323 to 528 VAC) 50/60 Hz				
		Rated current	2.1 A	2.8 A	3.9 A	5.9 A	7.6 A
		Heat value ^{*1}	32.2 W	48 W	49 W	65 W	108 W
	Control circuit	Power supply voltage	24 VDC (20.4 to 27.6 VAC)				
		Heat value ^{*1}	7 W	7 W	7W	10 W	13 W
Mass		Approx. 1.9 kg	Approx. 1.9 kg	Approx. 1.9 kg	Approx. 2.7 kg	Approx. 4.7 kg	
Maximum motor capacity	Rated effective current of motor	1.5 Arms	2.9 Arms	4.7 Arms	6.7 Arms	9.4 Arms	
	Maximum current of motor	4.5 Arms	8.7 Arms	14.1 Arms	19.7 Arms	28.2 Arms	

*1. The heat value is given for rated operation.

EtherCAT Communications Specifications

Item	Specification
Communications standard	IEC 61158 Type 12, IEC 61800-7 CiA 402 Drive Profile
Physical layer	100BASE-TX (IEEE802.3)
Connectors	RJ45 × 2 (shielded) ECAT IN: EtherCAT input ECAT OUT: EtherCAT output
Communications media	Ethernet Category 5 (100BASE-TX) or higher (twisted-pair cable with double, aluminum tape and braided shielding) is recommended.
Communications distance	Distance between nodes: 100 m max.
Process data	Fixed PDO mapping
Mailbox (CoE)	Emergency messages, SDO requests, SDO responses, and SDO information
Distributed clock (DC)	Synchronization in DC mode. DC cycle: 250 μs, 500 μs, 1 ms, 2 ms, 4 ms
LED indicators	L/A IN (Link/Activity IN) × 1 L/A OUT (Link/Activity OUT) × 1 RUN × 1 ERR × 1
CiA402 Drive Profile	<ul style="list-style-type: none"> • Cyclic synchronous position mode • Cyclic synchronous velocity mode • Cyclic synchronous torque mode • Profile position mode • Homing mode • Touch probe function (Latch function) • Torque limit function

Version Information

Unit Versions

● AC Servo Drives with built-in EtherCAT communications Linear motor type and Software

Unit	Model	Unit version
		Unit version 1.1
AC Servo Drives G5-Series built-in EtherCAT Communications Linear Motor Type	R88D-KN□□□-ECT-L	Supported
Compatible Sysmac Studio version		Version 1.04 or higher
Compatible CX-Drive version		Version 2.72 or higher

Components and Functions

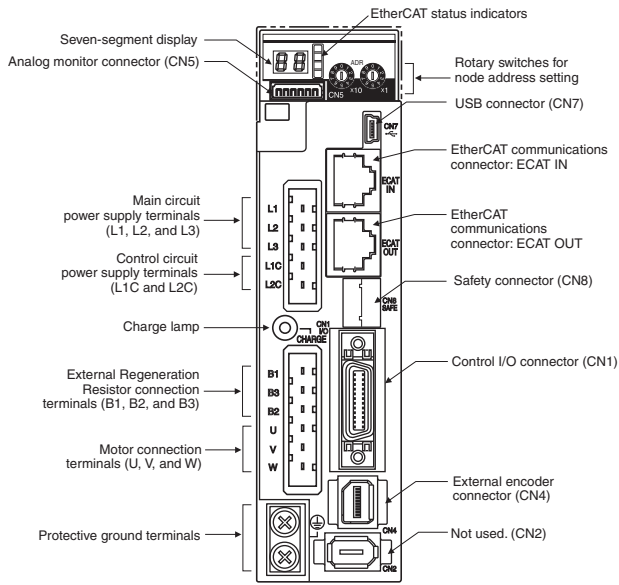

Display

A 2-digit 7-segment display shows the node address, error codes, and other Servo Drive status.

Charge Lamp

Lights when the main circuit power supply is turned ON.

EtherCAT Status Indicators

These indicators show the status of EtherCAT communications. For details, refer to the G5 series USER'S MANUAL (Cat.No.I576).

Control I/O Connector (CN1)

Used for command input signals and I/O signals.

External Encoder Connector (CN4)*

Connector for an encoder signal used during fully-closed control.

EtherCAT Communications Connectors (ECAT IN and ECAT OUT)

These connectors are for EtherCAT communications.

Analog Monitor Connector (CN5)

You can use a special cable to monitor values, such as the motor rotation speed, torque command value, etc.

USB Connector (CN7)

Communications connector for the computer.

Safety Connector (CN8)

Connector for safety devices.

If no safety devices are used, keep the factory-set safety bypass connector installed.

AC Servomotor/Drive G5-series

*External Encoder

Contact the encoder manufacturer to find out the detailed specifications such as operating environment before use.

External encoder type	Maker	Example of External encoder	Supported speed ^{*1}	Resolution [μm] ^{*4}	Maximum speed ^{*4} [m/s]
90° phase difference output type ^{*2*}	–	Phase A/B type	0 to 4 Mpps (Multiplication \times 4)	–	–
Serial communications type (Incremental type) ^{*3}	Magnescale Co., Ltd	SR75	0 to 400 Mpps	0.01 to 1	3.3
		SR85		0.01 to 1	3.3
		SL700+PL101RP/RHP		0.1	10
		SL710+PL101RP/RHP		0.1	10
Serial communications type (Absolute type) ^{*3}	Mitutoyo Corporation	AT573A	0 to 400 Mpps	0.05	2.5
		ST778A(L)		0.1	5
	Magnescale Co., Ltd	SR77		0.01 to 1	3.3
		SR87		0.01 to 1	3.3
	Renishaw Co.	RESOLUTE		0.001	0.4
				0.05	20
				0.1	40
	FAGOR AUTOMATION	SAP/SVAP/GAP		0.05	2.5
LAP		0.1	2		

***1.** The supported speed is the internal feedback pulse speed [external encoder pulse/s] of the external encoder that can be processed by the Servo Drive.

Check the instruction manual of the external encoder for the speed range supported by your external encoder.

***2.** These are the directions that the Drive counts a 90° phase difference output.

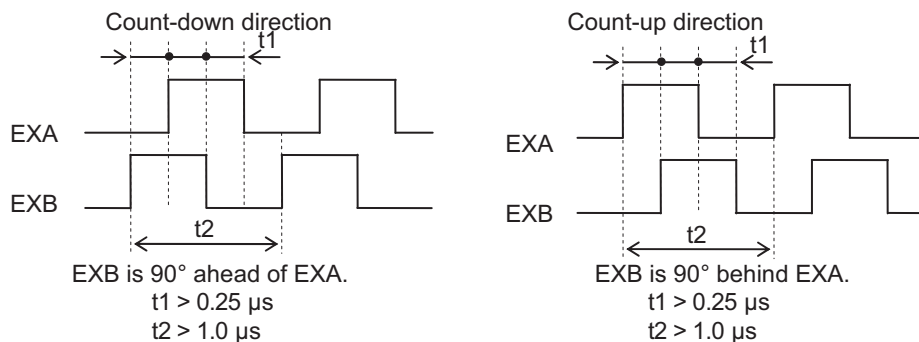

***3.** For the external encoder connection direction, set the direction so that count-up occurs when the motor shaft is rotating counterclockwise, and count-down occurs when the motor shaft is rotating clockwise. If the connection direction cannot be selected due to installation conditions or any other reason, the count direction can be reversed using External Feedback Pulse Direction Switching (3326 hex).

***4.** The resolution and maximum speed are the values for the G5-series Servo Drive. The resolution and maximum speed may be different from the specifications of the feedback encoder due to restriction on the maximum pulse frequency of the Servo Drive.

Dimensions

Refer to the page of Dimensions of the built-in EtherCAT communication type.

G5-Series AC Servo Drives with General-purpose Pulse Train or Analog Inputs

R88D-KT

Contents



- Ordering Information
- Specifications
 - General Specifications
 - Characteristics
 - Servo Drives with Single-phase 100 VAC Input Power
 - Servo Drives with Single-phase or three-phase 200 VAC Input Power
 - Servo Drives with Three-phase 200 VAC Input Power
 - Servo Drives with 400 VAC Input Power
- Names and Functions
 - Servo Drive Part Names
 - Functions
- Dimensions



Ordering Information

Refer to the Ordering Information.

Specifications

General Specifications

Item		Specifications	
Ambient operating temperature and humidity		0 to 55°C, 90% max. (with no condensation)	
Storage ambient temperature and humidity		-20 to 65°C, 90% max. (with no condensation)	
Operating and storage atmosphere		No corrosive gases	
Vibration resistance		10 to 60 Hz and at an acceleration of 5.88 m/s ² or less (Not to be run continuously at the resonance point)	
Insulation resistance		Between power supply terminal/power terminal and FG terminal: 0.5 MΩ min. (at 500 VDC Megger)	
Dielectric strength		Between power supply/power line terminals and FG terminal: 1,500 VAC for 1 min at 50/60 Hz	
Protective structure		Built into panel	
International standard	EC directives	EMC directive	EN55011, EN61000-6-2, IEC61800-3
		Low voltage command	EN61800-5-1
		Machinery directives	EN954-1 (Cat.3), EN ISO 13849-1: 2008 (PLC,d), ISO 13849-1: 2006 (PLC,d), EN61508 (SIL2), EN62061 (SIL2), EN61800-5-2 (STO), IEC61326-3-1 (SIL2)
	UL standards	UL508C *	
	CSA standards	CSA22.2 No.14	
Korean Radio Regulations (KC)		Certified	

* The Servo drive of R88D-KT20□ and smaller capacity the one are UL-Listed.

The Servo drive of R88D-KT30□ and bigger capacity the one are UL-Recognized.

Note: 1. The above items reflect individual evaluation testing. The results may differ under compound conditions.

Note: 2. Always disconnect all connections to the Servo Drive before you perform insulation resistance tests on it. If you perform an insulation resistance test while the Servo Drive is connected, the Servo Drive may be damaged. Never perform dielectric strength tests on the Servo Drive. Failure to follow this precaution may result in damaging internal elements.

Note: 3. Some Servo Drive parts will require maintenance. For details, refer to the G5 series USER'S MANUAL. Confirm the Manual No. that is listed in Related Manuals.

Note: 4. To conform EMC directive, the tips on wiring and installation written in the G5 series user's manual must be followed. Confirm the Manual No. that is listed in Related Manuals.

G5-Series
System Configuration

EtherCAT Communications
AC Servo Drive

EtherCAT Communications
Linear Motor Type
AC Servo Drive

General-purpose Inputs
AC Servo Drive

ML-II Type
AC Servo Drive

AC Servomotors

Linear Motor

Characteristics

● Servo Drives with 100 VAC Input Power for Single-phase input type

Item			R88D-KTA5L	R88D-KT01L	R88D-KT02L	R88D-KT04L
Continuous output current (rms)			1.2A	1.7A	2.5A	4.6A
Input power supply	Main circuit	Power supply capacity	0.4KVA	0.4KVA	0.5KVA	0.9KVA
		Power supply voltage	Single-phase 100 to 115 VAC (85 to 127 V), 50/60 Hz			
		Rated current	1.7A	2.6A	4.3A	7.6A
		Heat value*1	11W	16.6W	21W	25W
	Control circuit	Power supply voltage	Single-phase 100 to 120 VAC (85 to 132 V), 50/60 Hz			
		Heat value*1	4W	4W	4W	4W
Weight			Approx. 0.8 kg	Approx. 0.8kg	Approx. 1.0kg	Approx. 1.6kg
Maximum applicable motor capacity			50W	100W	200W	400W
Applicable Servomotors (R88M-)	3,000 r/min Servomotors	INC	K05030H	K10030L	K20030L	K40030L
		ABS	K05030T	K10030S	K20030S	K40030S
	2,000 r/min Servomotors	ABS	-	-	-	-
		ABS	-	-	-	-

*1. The heat value is given for rated operation.

● Servo Drives with 200 VAC Input Power for Single-phase/Three-phase input type

Item			R88D-KT01H	R88D-KT02H	R88D-KT04H	R88D-KT08H	R88D-KT10H	R88D-KT15H
Continuous output current (rms)			1.2A	1.6A	2.6A	4.1A	5.9A	9.4A
Input power supply	Main circuit	Power supply capacity	0.5KVA	0.5KVA	0.9KVA	1.3KVA	1.8KVA	2.3KVA
		Power supply voltage	Single-phase or Three-phase 200 to 240 VAC (170 to 264 V), 50/60 Hz					
		Rated current	1.6/0.9A*1	2.4/1.3A *1	4.1/2.4A *1	6.6/3.6A *1	9.1/5.2A *1	14.2/8.1A *1
		Heat value*2	14.3/13.7W*1	23/19W*1	33/24W*1	30/35.5W*1	57/49W*1	104/93W*1
	Control circuit	Power supply voltage	Single-phase 200 to 240VAC (170 to 264V), 50/60Hz					
		Heat value*2	4W	4W	4W	4W	7W	7W
Weight			Approx. 0.8kg	Approx. 0.8kg	Approx. 1.1kg	Approx. 1.6kg	Approx. 1.8kg	Approx. 1.8kg
Maximum applicable motor capacity			100W	200W	400W	750W	1kW	1.5kW
Applicable Servomotors (R88M-)	3,000 r/min Servomotors	INC	K05030H K10030H	K20030H	K40030H	K75030H	-	K1K030H K1K530H
		ABS	K05030T K10030T	K20030T	K40030T	K75030T	-	K1K030T K1K530T
	2,000 r/min Servomotors	INC	-	-	-	-	K1K020H	K1K520H
		ABS	-	-	-	-	K1K020T	K1K520T
	1,000 r/min Servomotors	INC	-	-	-	-	-	K90010H
		ABS	-	-	-	-	-	K90010T

*1. The left value is for single-phase input power and the right value is for three-phase input power.

*2. The heat value is given for rated operation.

● Servo Drives with 200 VAC Input Power
for Three-phase input type

Item			R88D-KT20H	R88D-KT30H	R88D-KT50H	R88D-KT75H	R88D-KT150H	
Continuous output current (rms)			13.4A	18.7A	33.0A	44.0A	66.1A	
Input power supply	Main circuit	Power supply capacity	3.3KVA	4.5KVA	7.5KVA	11.0KVA	22.0KVA	
		Power supply voltage	3-phase 200 to 230 VAC (170 to 253 V), 50/60 Hz				3-phase 200 to 230 VAC (170 to 253V) 50/60Hz 280 to 325 VDC (238 to 357V)	
		Rated current	11.8A	15.1A	21.6A	32.0A	58.0A	
		Heat value*1	139W	108W	328W	381W	720W	
	Control circuit	Power supply voltage	Single-phase 200 to 230 VAC (170 to 253 V), 50/60 Hz				Single-phase 200 to 230 VAC (170 to 253V) 50/60Hz 280 to 325 VDC (238 to 357V)	
		Heat value*1	10W	13W	13W	15W	17W	
Weight			Approx. 2.7kg	Approx. 4.8kg	Approx. 4.8kg	Approx. 13.5kg	Approx. 21.0kg	
Maximum applicable motor capacity			2kW	3kW	5kW	7.5kW	15kW	
Applicable Servomotors (R88M-)	3,000 r/min Servomotors	INC	K2K030H	K3K030H	K4K030H K5K030H	-	-	
		ABS	K2K030T	K3K030T	K4K030T K5K030T	-	-	
	2,000 r/min, 1,500 r/min Servomotors	INC	K2K020H	K3K020H	K4K020H K5K020H	-	-	
		ABS	K2K020T	K3K020T	K4K020T K5K020T	K7K515T	K11K015T K15K015T	
	1,000 r/min Servomotors	INC	-	K2K010H	K3K010H	-	-	
		INC	-	K2K010T	K3K010T K4K510T	K6K010T	-	

*1. The heat value is given for rated operation.

● Servo Drives with 400 VAC Input Power
for Three-phase input type

Item			R88D-KT06F	R88D-KT10F	R88D-KT15F	R88D-KT20F	R88D-KT30F	R88D-KT50F	R88D-KT75F	R88D-KT150F
Continuous output current (rms)			1.5A	2.9A	4.7A	6.7A	9.4A	16.5A	22.0A	33.4A
Input power supply	Main circuit	Power supply capacity	1.2KVA	1.8KVA	2.3KVA	3.8KVA	4.5KVA	6.0KVA	11.0KVA	22.0KVA
		Power supply voltage	3-phase 380 to 480 VAC (323 to 528 V), 50/60 Hz							
		Rated current	2.1A	2.8A	3.9A	5.9A	7.6A	12.1A	16.0A	29.0A
		Heat value*1	32.2W	48W	49W	65W	108W	200W	300W	590W
	Control circuit	Power supply voltage	24 VDC (20.4 to 27.6)							
		Heat value*1	7W	7W	7W	10W	13W	13W	15W	22W
Weight			Approx. 1.9kg	Approx. 1.9kg	Approx. 1.9kg	Approx. 2.7kg	Approx. 4.7kg	Approx. 4.7kg	Approx. 13.5kg	Approx. 21.0kg
Maximum applicable motor capacity			600W	1kW	1.5kW	2kW	3kW	5kW	7.5kW	15kW
Applicable Servomotors (R88M-)	3,000 r/min Servomotors	INC	-	K75030F	K1K030F K1K530F	K2K030F	K3K030F	K4K030F K5K030F	-	-
		ABS	-	K75030C	K1K030C K1K530C	K2K030C	K3K030C	K4K030C K5K030C	-	-
	2,000 r/min, 1,500 r/min Servomotors	INC	K40020F K60020F	K1K020F	K1K520F	K2K020F	K3K020F	K4K020F K5K020F	-	-
		ABS	K40020C K60020C	K1K020C	K1K520C	K2K020C	K3K020C	K4K020C K5K020C	K7K515C	K11K015C K15K015C
	1,000 r/min Servomotors	INC	-	-	K90010F	-	K2K010F	K3K010F	-	-
		ABS	-	-	K90010C	-	K2K010C	K3K010C K4K510C	K6K010C	-

*1. The heat value is given for rated operation.

Components and Functions

Servo Drive Part Names

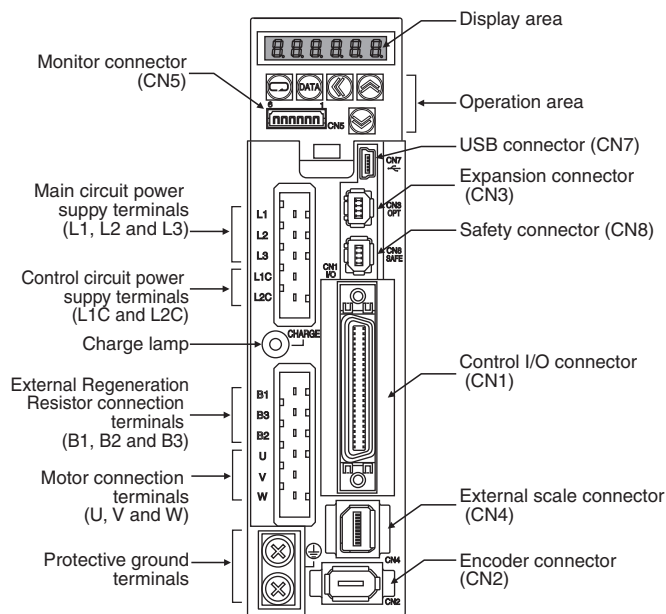

Display area

A 6-digit 7-segment LED display shows the Servo Drive status, alarm codes, parameters, and other information.

Operation area

Monitors the parameter setting and driver condition.

Charge Lamp

Lights when the main circuit power supply is turned ON.

Control I/O Connector (CN1)

Used for command input signals and I/O signals.

Encoder connector (CN2)

Connector for the encoder installed in the Servomotor.

Expansion Connector (CN3)

A spare connector for expansion. Do not connect anything.

External Scale Connector (CN4)

Connector for an encoder signal used during full closing control.

Monitor Connector (CN5)

Uses a specified cable to monitor the motor rotation speed, torque command value, etc.

USB connector (CN7)

Communications connector for the computer.

Safety Connector (CN8)

Connector for the safety devices.

If no safety device is used, keep the factory-set safety bypass connector installed.

Main Circuit Terminal (CNA)

Main-circuit power terminals (L1, L2, L3)

Control-circuit power terminals (CNA)

Motor connection terminals (CNB)

External Regeneration Resistor connection terminals (B1,B2,B3)

Servomotor connection terminals (U, V, W)

*External Encoder

Contact the encoder manufacturer to find out the detailed specifications such as operating environment before use.

External encoder type	Maker	Example of External encoder	Supported speed*1	Resolution*4 [μm]	Maximum speed*4 [m/s]
90° phase difference output type*2*3	–	Phase A/B type	0 to 4 Mpps (Multiplication × 4)	–	–
Serial communications type (Incremental type)*3	Magnescale Co., Ltd	SR75	0 to 400 Mpps	0.01 to 1	3.3
		SR85		0.01 to 1	3.3
		SL700+PL101RP/RHP		0.1	10
		SL710+PL101RP/RHP		0.1	10

*1. The supported speed is the internal feedback pulse speed [external encoder pulse/s] of the external encoder that can be processed by the Servo Drive.

Check the instruction manual of the external encoder for the speed range supported by your external encoder.

*2. These are the directions that the Drive counts a 90° phase difference output.

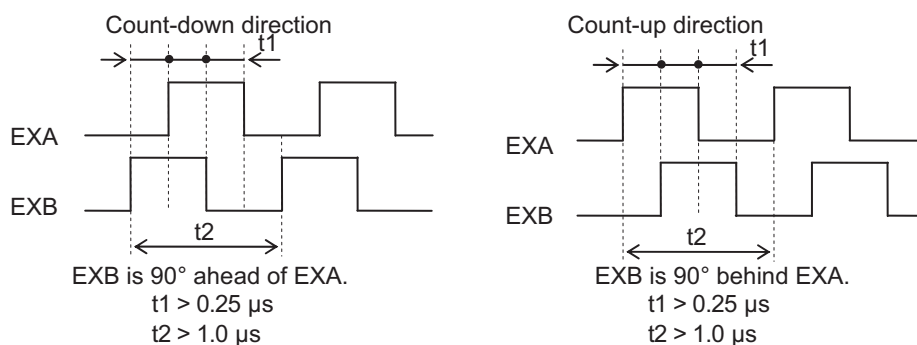

*3. For the external encoder connection direction, set the direction so that count-up occurs when the motor shaft is rotating counterclockwise, and count-down occurs when the motor shaft is rotating clockwise. If the connection direction cannot be selected due to installation conditions or any other reason, the count direction can be reversed using External Feedback Pulse Direction Switching (3326 hex).

*4. The resolution and maximum speed are the values for the G5-series Servo Drive. The resolution and maximum speed may be different from the specifications of the feedback encoder due to restriction on the maximum pulse frequency of the Servo Drive.

Functions

Basic control

Position control	Internally set speed control
Speed control	Switching control
Torque control	Full closing control*

* Absolute type external encoder can not connected.

Advanced control

Vibration control	Gain switching	Friction torque compensation function
Adaptive filter	Torque limit	Inertia ratio switching function
Notch filter	Sequence I/O signal	Hybrid Vibration Suppression Function
Electronic gear function	Forward and reverse drive prohibition functions	Feed-forward function
Encoder dividing function	Disturbance observer function	Instantaneous speed observer function
Brake interlock	Gain switching 3 function	

Other functions

Safe Torque OFF (STO) Function

Realtime autotuning

Manual tuning

Various parameters

Basic Parameters	Interface Monitor Setting Parameters
Gain Parameters	Extended Parameters
Vibration Suppression Parameters	Special Parameters
Analog Control Parameters	

Dimensions

<Wall Mounting>

Single-phase 100 VAC R88D-KTA5L/-KT01L (50 to 100W)

Single-phase/Three-phase 200 VAC R88D-KT01H/-KT02H (100 to 200W)

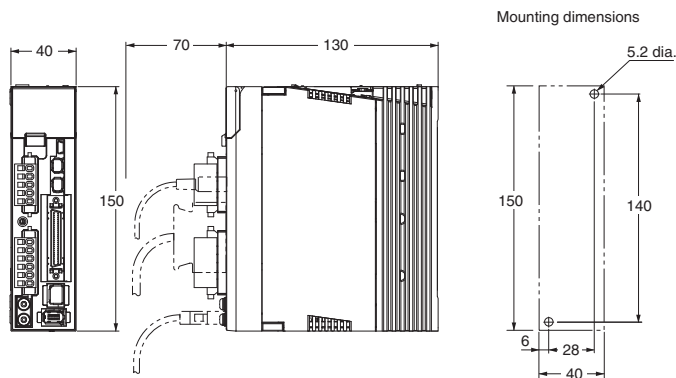

CAD data

Single-phase/Three-phase 100 VAC R88D-KT02L (200W)

Single-phase/Three-phase 200 VAC R88D-KT04H (400W)

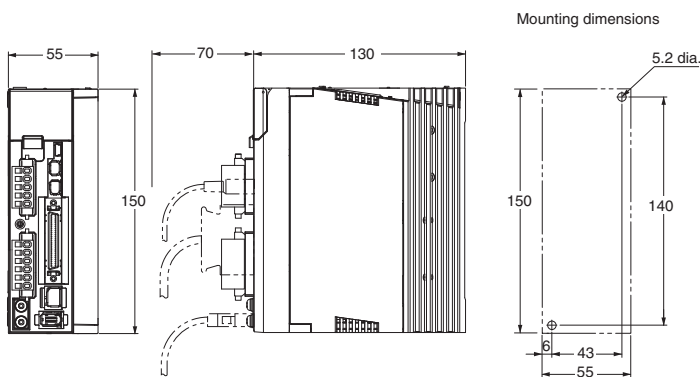

CAD data

Single-phase 100 VAC R88D-KT04L (400W)

Single-phase/Three-phase 200 VAC R88D-KT08H (750W)

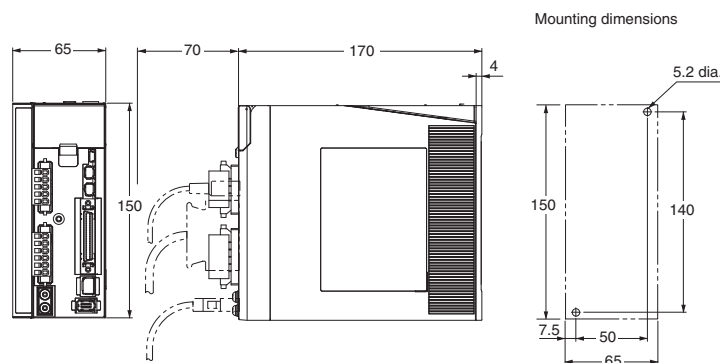

CAD data

Single-phase/Three-phase 200 VAC R88D-KT10H/-KT15H (900W to 1.5kW)

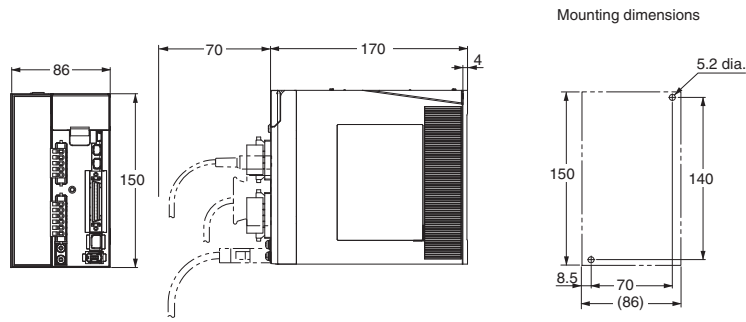

CAD data

Three-phase 200 VAC R88D-KT20H (2kW)

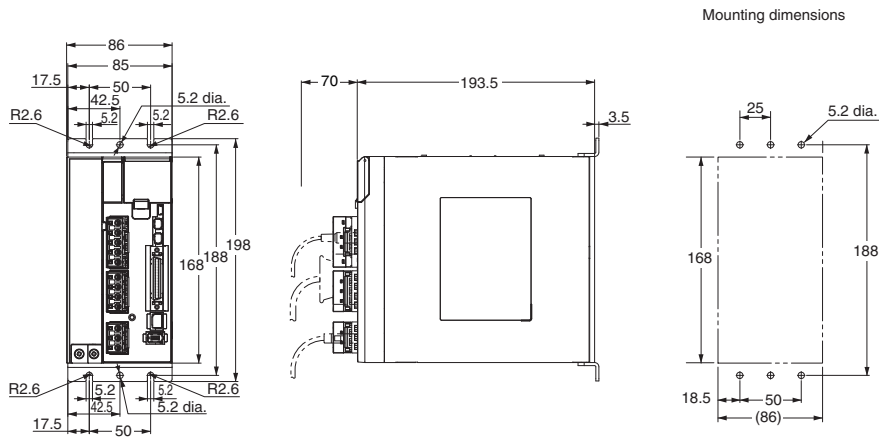

CAD data

Three-phase 200 VAC R88D-KT30H/-KT50H (3 to 5kW)

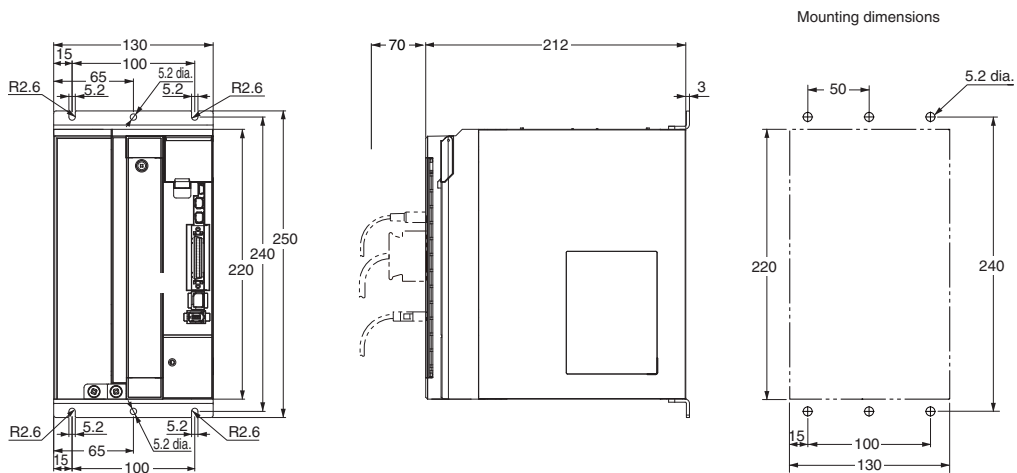

CAD data

Three-phase 200 VAC R88D-KT75H (7.5kW)

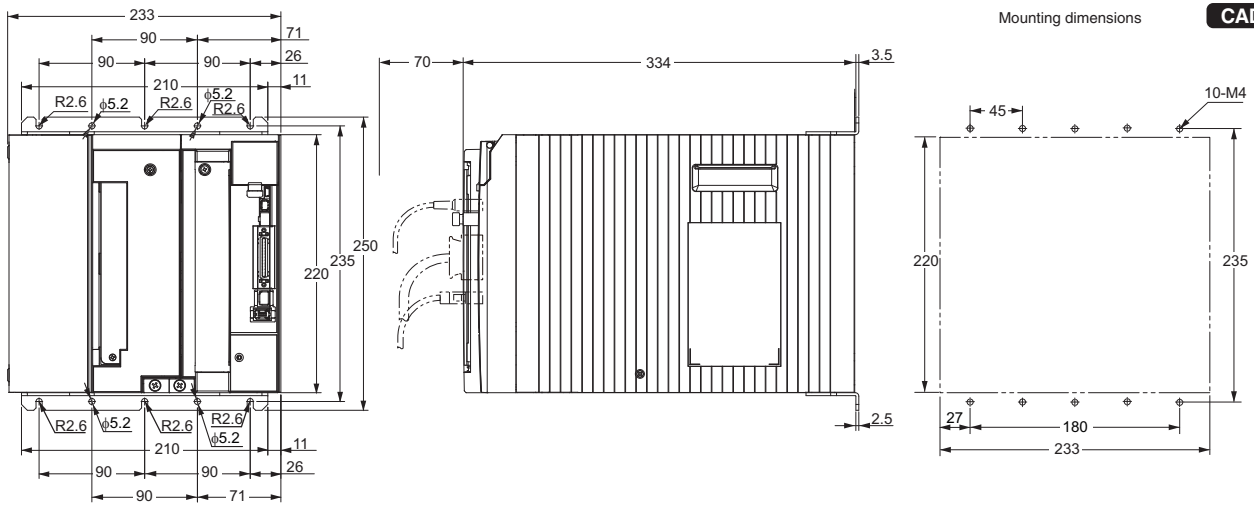

Three-phase 200 VAC R88D-KT150H (15kW)

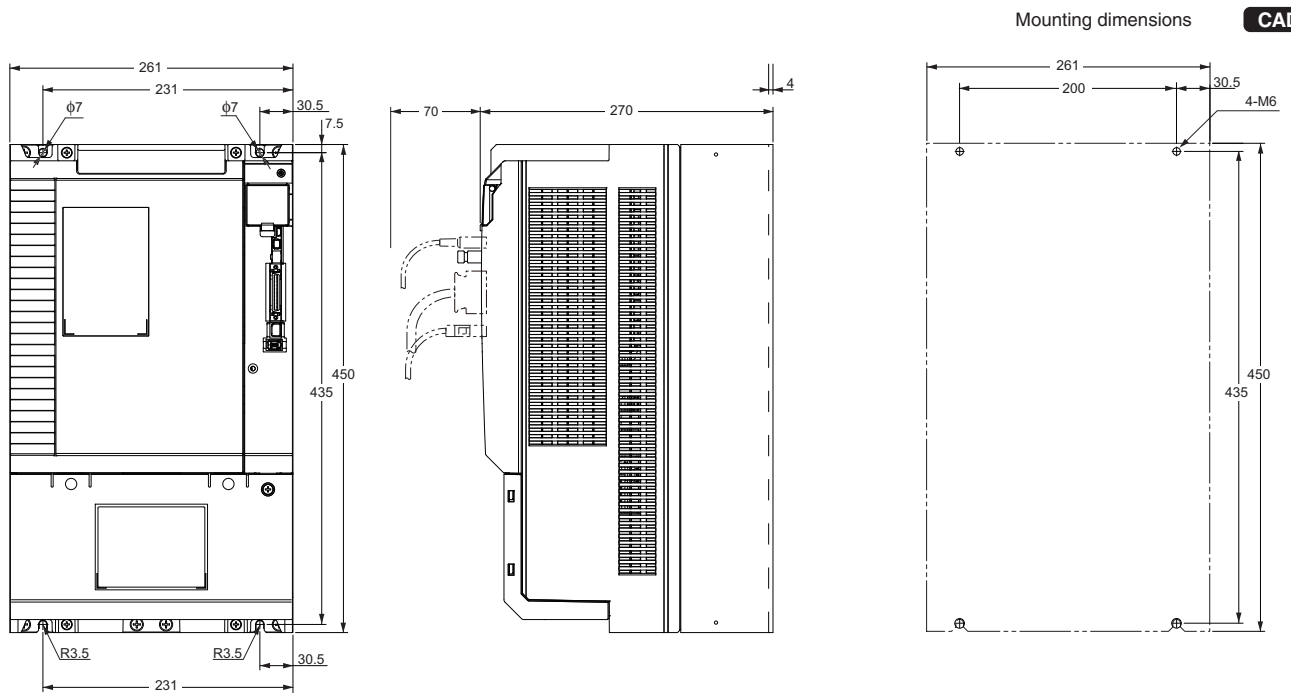

G5-Series
System Configuration

EtherCAT Communications
AC Servo Drive

EtherCAT Communications
Linear Motor Type
AC Servo Drive

General-purpose Inputs
AC Servo Drive

ML-II Type
AC Servo Drive

AC Servomotors

Linear Motor

Three-phase 400 VAC R88D-KT06F/-KT10F/-KT15F (600W to 1.5kW)

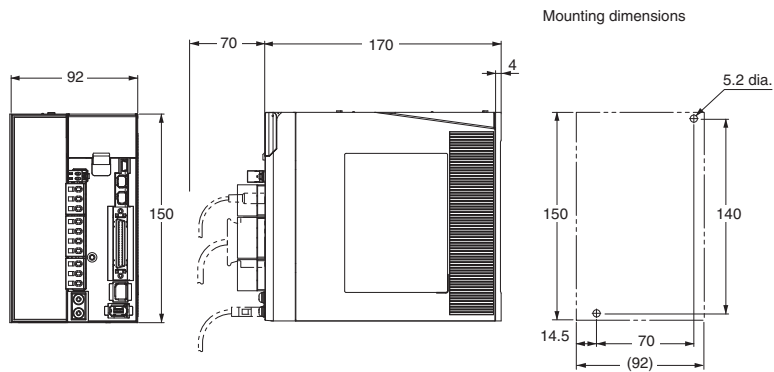

Three-phase 400 VAC R88D-KT20F (2kW)

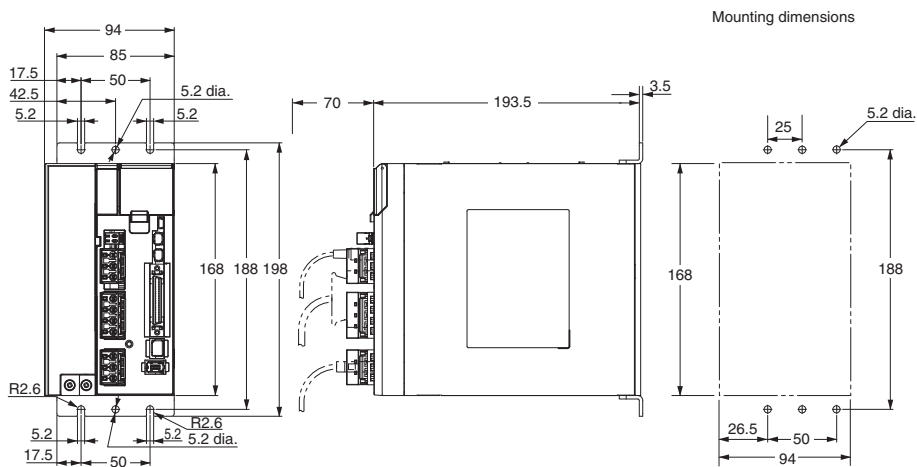

Three-phase 400 VAC R88D-KT30F/-KT50F (3 to 5kW)

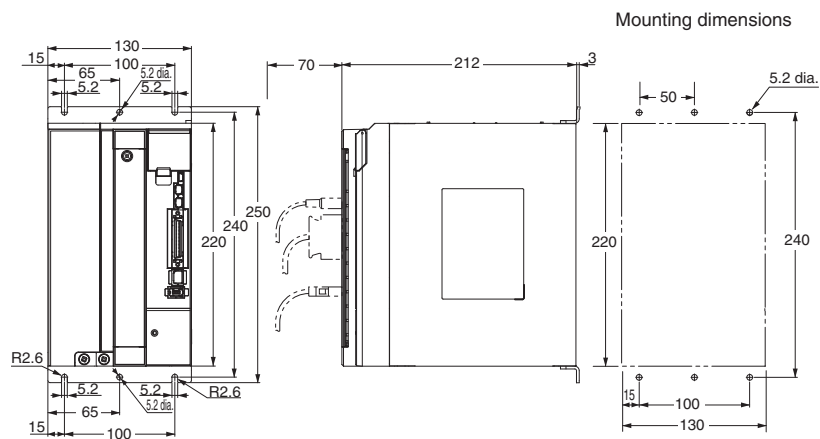

Three-phase 400 VAC: R88D-KT75F (7.5kW)

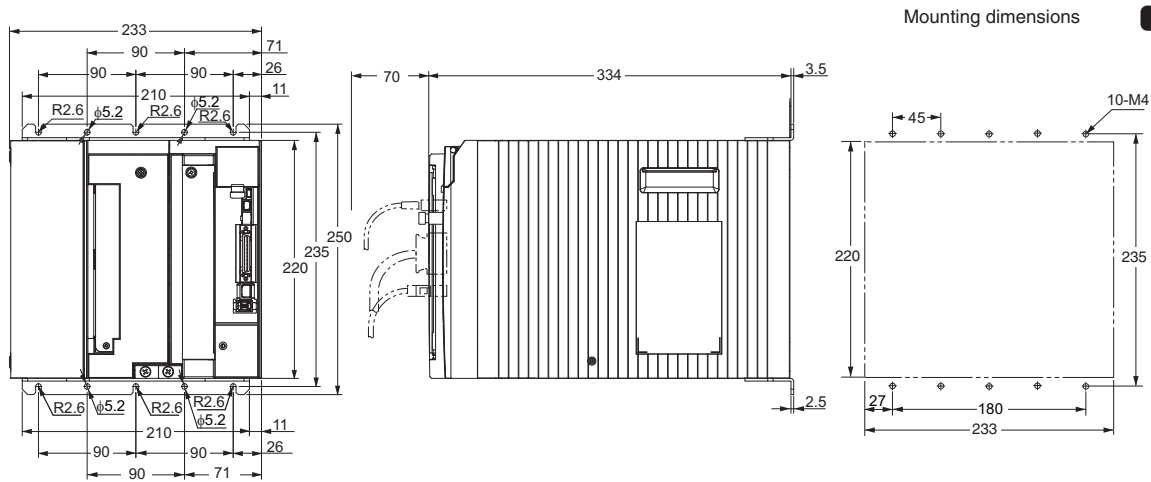

Mounting dimensions

CAD data

Three-phase 400 VAC R88D-KT150F (150kW)

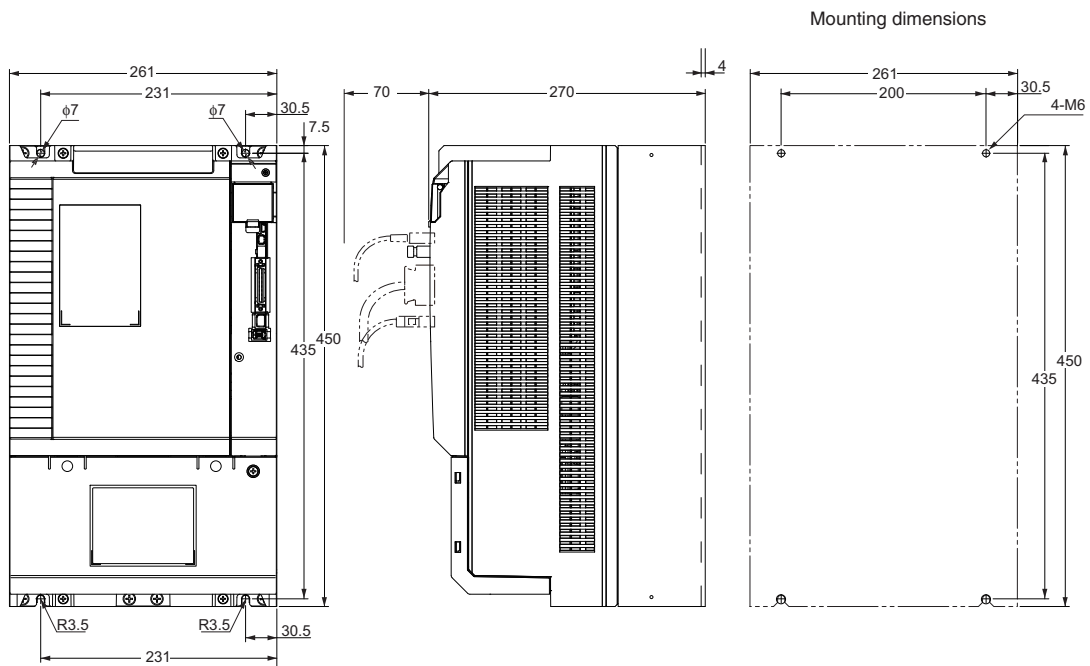

Mounting dimensions

CAD data

G5-Series
System Configuration

EtherCAT Communications
AC Servo Drive

EtherCAT Communications
Linear Motor Type
AC Servo Drive

General-purpose Inputs
AC Servo Drive

ML-II Type
AC Servo Drive

AC Servomotors

Linear Motor

R88D-KN□-ML2

Contents



- Ordering Information
- Specifications
 - General Specifications
 - Characteristics
 - Servo Drives with Single-phase 100 VAC Input Power
 - Servo Drives with Single-phase or three-phase 200 VAC Input Power
 - Servo Drives with Three-phase 200 VAC Input Power
 - Servo Drives with 400 VAC Input Power
- Names and Functions
 - Servo Drive Part Names
 - Functions
- Dimensions

Ordering Information

Refer to the Ordering Information.

Specifications

General Specifications

Item		Specifications	
Ambient operating temperature and operating humidity		0 to +55C, 90% RH max. (with no condensation)	
Storage ambient temperature and humidity		-20 to +65C, 90% RH max. (with no condensation)	
Operating and storage atmosphere		No corrosive gases	
Vibration resistance		10 to 60 Hz and at an acceleration of 5.88 m/s ² or less (Not to be run continuously at the resonance point)	
Insulation resistance		Between power supply terminal/power terminal and FG terminal: 0.5 MΩ min. (at 500 VDC Megger)	
Dielectric strength		Between power supply/power line terminals and FG terminal: 1,500 VAC for 1 min at 50/60 Hz	
Protective structure		Built into panel	
International standard	EC directives	EMC directive	EN55011, EN61000-6-2, IEC61800-3
		Low voltage directive	EN61800-5-1
		Machinery directives	EN954-1 (Cat.3), EN ISO 13849-1: 2008 (PLC,d), ISO 13849-1: 2006 (PLC,d), EN61508 (SIL2), EN62061 (SIL2), EN61800-5-2 (STO), IEC61326-3-1 (SIL2)
	UL standards	UL508C	
	CSA standards	CSA22.2 No.14	
Korean Radio Regulations (KC)		Certified	

Note: 1. The above items reflect individual evaluation testing. The results may differ under compound conditions.

Note: 2. Always disconnect all connections to the Servo Drive before you perform insulation resistance tests on it. If you perform an insulation resistance test while the Servo Drive is connected, the Servo Drive may be damaged. Never perform dielectric strength tests on the Servo Drive. Failure to follow this precaution may result in damaging internal elements.

Note: 3. Some Servo Drive parts will require maintenance. For details, refer to the G5 series USER'S MANUAL. Confirm the Manual No. that is listed in Related Manuals.

Characteristics

● Servo Driver with 100 VAC Input Power for Single-phase input type

Item			R88D-KNA5L-ML2	R88D-KN01L-ML2	R88D-KN02L-ML2	R88D-KN04L-ML2
Continuous output current (rms)			1.2A	1.7A	2.5A	4.6A
Input power supply	Main circuit	Power supply capacity	0.4KVA	0.4KVA	0.5KVA	0.9KVA
		Power supply voltage	Single-phase 100 to 120 VAC (85 to 132 V), 50/60 Hz			
		Rated current	1.7A	2.6A	4.3A	7.6A
		Heat value*1	11W	16.6W	21W	25W
	Control circuit	Power supply voltage	Single-phase 100 to 120 VAC (85 to 132 V), 50/60 Hz			
		Heat value*1	4W	4W	4W	4W
Weight			Approx. 0.8 kg	Approx. 0.8kg	Approx. 1.0kg	Approx. 1.6kg
Maximum applicable motor capacity			50W	100W	200W	400W
Applicable Servomotors (R88M-)	3,000 r/min Servomotors	INC	K05030H	K10030L	K20030L	K40030L
		ABS	K05030T	K10030S	K20030S	K40030S
	2,000 r/min Servomotors	ABS	-	-	-	-
		ABS	-	-	-	-
	1,000 r/min Servomotors	ABS	-	-	-	-
		ABS	-	-	-	-

*1. The heat value is given for rated operation.

● Servo Driver with 200 VAC Input Power for Single-phase/Three-phase input type

Item			R88D-KN01H-ML2	R88D-KN02H-ML2	R88D-KN04H-ML2	R88D-KN08H-ML2	R88D-KN10H-ML2	R88D-KN15H-ML2
Continuous output current (rms)			1.2A	1.6A	2.6A	4.1A	5.9A	9.4A
Input power supply	Main circuit	Power supply capacity	0.5KVA	0.5KVA	0.9KVA	1.3KVA	1.8KVA	2.3KVA
		Power supply voltage	Single-phase or Three-phase 200 to 240 VAC (170 to 264 V), 50/60 Hz					
		Rated current	1.6/0.9A *1	2.4/1.3A *1	4.1/2.4A *1	6.6/3.6A *1	9.1/5.2A *1	14.2/8.1A *1
		Heat value*2	14.3/13.7W *1	23/19 W *1	33/24 W *1	30/35.5 W *1	57/49 W *1	104/93 W *1
	Control circuit	Power supply voltage	Single-phase 200 to 240 VAC (170 to 264 V), 50/60 Hz					
		Heat value*2	4W	4W	4W	4W	7W	7W
Weight			Approx. 0.8kg	Approx. 0.8kg	Approx. 1.1kg	Approx. 1.6kg	Approx. 1.8kg	Approx. 1.8kg
Maximum applicable motor capacity			100W	200W	400W	750W	1kW	1.5kW
Applicable Servomotors (R88M-)	3,000 r/min Servomotors	INC	K05030H K10030H	K20030H	K40030H	K75030H	-	K1K030H K1K530H
		ABS	K05030T K10030T	K20030T	K40030T	K75030T	-	K1K030T K1K530T
	2,000 r/min Servomotors	INC	-	-	-	-	K1K020H	K1K520H
		ABS	-	-	-	-	K1K020T	K1K520T
	1,000 r/min Servomotors	INC	-	-	-	-	-	K90010H
		ABS	-	-	-	-	-	K90010T

*1. The left value is for single-phase input power and the right value is for three-phase input power.

*2. The heat value is given for rated operation.

AC Servomotor/Drive G5-series

● Servo Driver with 200 VAC Input Power for Three-phase input type

Item			R88D-KN20H-ML2	R88D-KN30H-ML2	R88D-KN50H-ML2
Continuous output current (rms)			13.4A	18.7A	33.0A
Input power supply	Main circuit	Power supply capacity	3.3KVA	4.5KVA	7.5KVA
		Power supply voltage	Three-phase 200 to 230 VAC (170 to 253 V), 50/60 Hz		
		Rated current	11.8A	15.1A	21.6A
		Heat value*1	139W	108W	328W
	Control circuit	Power supply voltage	Single-phase 200 to 230 VAC (170 to 253 V), 50/60 Hz		
		Heat value*1	10W	13W	13W
Weight			Approx. 2.7kg	Approx. 4.8kg	Approx. 4.8kg
Maximum applicable motor capacity			2kW	3kW	5kW
Applicable Servomotors (R88M-)	3,000 r/min Servomotors	INC	K2K030H	K3K030H	K4K030H K5K030H
		ABS	K2K030T	K3K030T	K4K030T K5K030T
	2,000 r/min Servomotors	INC	K2K020H	K3K020H	K4K020H K5K020H
		ABS	K2K020T	K3K020T	K4K020T K5K020T
	1,000 r/min Servomotors	INC	–	K2K010H	K3K010H
		INC	–	K2K010T	K3K010T

*1. The heat value is given for rated operation.

● Servo Driver with 400 VAC Input Power for Three-phase input type

Item			R88D-KN06F-ML2	R88D-KN10F-ML2	R88D-KN15F-ML2	R88D-KN20F-ML2	R88D-KN30F-ML2	R88D-KN50F-ML2
Continuous output current (rms)			1.5A	2.9A	4.7A	6.7A	9.4A	16.5A
Input power supply	Main circuit	Power supply capacity	1.2KVA	1.8KVA	2.3KVA	3.8KVA	4.5KVA	6.0KVA
		Power supply voltage	Single-phase 380 to 480 VAC (323 to 528 V), 50/60 Hz					
		Rated current	2.1A	2.8A	3.9A	5.9A	7.6A	12.1A
		Heat value*1	32.2W	48W	49W	65W	108W	200W
	Control circuit	Power supply voltage	24 VDC (20.4 to 27.6)					
		Heat value*1	7W	7W	7W	10W	13W	13W
Weight			Approx. 1.9kg	Approx. 1.9kg	Approx. 1.9kg	Approx. 2.7kg	Approx. 4.7kg	Approx. 4.7kg
Maximum applicable motor capacity			600W	1kW	1.5kW	2kW	3kW	5kW
Applicable Servomotors (R88M-)	3,000 r/min Servomotors	INC	–	K75030F	K1K030F K1K530F	K2K030F	K3K030F	K4K030F K5K030F
		ABS	–	K75030C	K1K030C K1K530C	K2K030C	K3K030C	K4K030C K5K030C
	2,000 r/min Servomotors	INC	K40020F K60020F	K1K020F	K1K520F	K2K020F	K3K020F	K4K020F K5K020F
		ABS	K40020C K60020C	K1K020C	K1K520C	K2K020C	K3K020C	K4K020C K5K020C
	1,000 r/min Servomotors	INC	–	–	K90010F	–	K2K010F	K3K010F
		ABS	–	–	K90010C	–	K2K010C	K3K010C

*1. The heat value is given for rated operation.

Components and Functions

Servo Drive Part Names

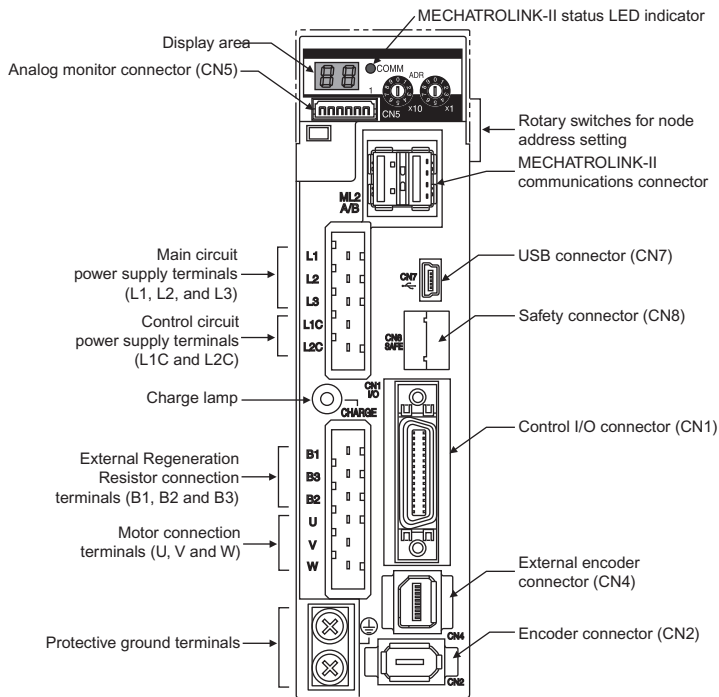

Display area

A 2-digit 7-segment LED indicator shows the node address, alarm codes, and other driver status.

Charge Lamp

Lits when the main circuit power supply is turned ON.

MECHATROLINK-II Status LED Indicator

Indicates the communications status of the MECHATROLINK-II.

Control I/O Connector (CN1)

Used for command input signals and I/O signals.

Encoder connector (CN2)

Connector for the encoder installed in the Servomotor.

External Encoder Connector (CN4)

Connector for an encoder signal used during full closing control.

Analog Monitor Connector (CN5)

2 analog outputs to monitor values like motor rotation speed, torque command value, etc.

MECHATROLINK-II Communications Connectors (ML2A and ML2B)

Connectors for MECHATROLINK-II communications.

USB Connector (CN7)

Communications Connector for the computer.

Safety Connector (CN8)

Connector for the safety devices.

If no safety device is used, keep the factory-set safety bypass connector installed.

AC Servomotor/Drive G5-series

*External Encoder

Contact the encoder manufacturer to find out the detailed specifications such as operating environment before use.

External encoder type	Maker	Example of External encoder	Supported speed*1	Resolution*4 [μm]	Maximum speed*4 [m/s]
90° phase difference output type*2*3	–	Phase A/B type	0 to 4 Mpps (Multiplication \times 4)	–	–
Serial communications type (Incremental type)*3	Magnescale Co., Ltd	SR75	0 to 400 Mpps	0.01 to 1	3.3
		SR85		0.01 to 1	3.3
		SL700+PL101RP/RHP		0.1	10
		SL710+PL101RP/RHP		0.1	10
Serial communications type (Absolute type)*3	Mitutoyo Corporation	AT573A	0 to 400 Mpps	0.05	2.5
		ST778A(L)		0.1	5
	Magnescale Co., Ltd	SR77		0.01 to 1	3.3
		SR87		0.01 to 1	3.3
	Renishaw Co.	RESOLUTE		0.001	0.4
				0.05	20
				0.1	40
	FAGOR AUTOMATION	SAP/SVAP/GAP		0.05	2.5
LAP		0.1	2		

*1. The supported speed is the internal feedback pulse speed [external encoder pulse/s] of the external encoder that can be processed by the Servo Drive.

Check the instruction manual of the external encoder for the speed range supported by your external encoder.

*2. These are the directions that the Drive counts a 90° phase difference output.

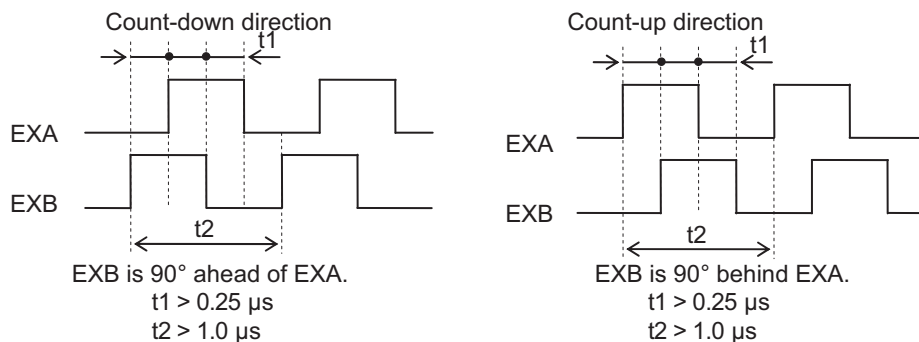

*3. For the external encoder connection direction, set the direction so that count-up occurs when the motor shaft is rotating counterclockwise, and count-down occurs when the motor shaft is rotating clockwise. If the connection direction cannot be selected due to installation conditions or any other reason, the count direction can be reversed using External Feedback Pulse Direction Switching (3326 hex).

*4. The resolution and maximum speed are the values for the G5-series Servo Drive. The resolution and maximum speed may be different from the specifications of the feedback encoder due to restriction on the maximum pulse frequency of the Servo Drive.

Functions

Basic control

Position control	Internally set speed control
Speed control	Switching control
Torque control	Full closing control

Advanced control

Vibration control	Gain switching	Friction torque compensation function
Adaptive filter	Torque limit	Inertia ratio switching function
Notch filter	Sequence I/O signal	Hybrid Vibration Suppression Function
Electronic gear function	Forward and reverse drive prohibition functions	Feed-forward function
Encoder dividing function	Disturbance observer function	Instantaneous speed observer function
Brake interlock	Gain switching 3 function	

Other functions

Safe Torque OFF (STO) Function

Realtime autotuning

Manual tuning

Various parameters

Basic Parameters	Interface Monitor Setting Parameters
Gain Parameters	Extended Parameters
Vibration Suppression Parameters	Special Parameters
Analog Control Parameters	

Dimensions

<Wall Mounting>

Single-phase 100VAC R88D-KNA5L-ML2/-KN01L-ML2 (50 to 100W)

Single-phase/Three-phase 200VAC R88D-KN01H-ML2/-KN02H-ML2 (100 to 200W)

External dimensions

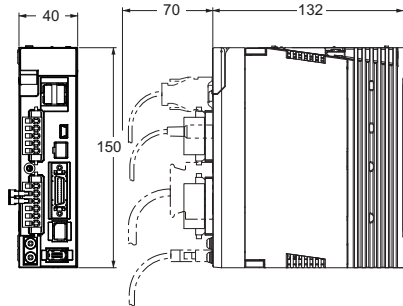

Mounting dimensions

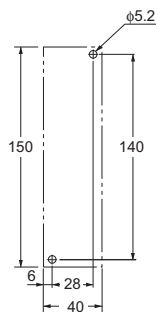

Single-phase/Three-phase 100VAC R88D-KN02L-ML2 (200W)

Single-phase/Three-phase 200VAC R88D-KN04H-ML2 (400W)

External dimensions

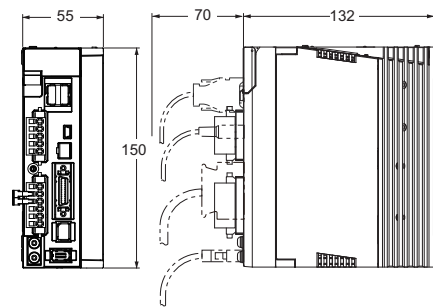

Mounting dimensions

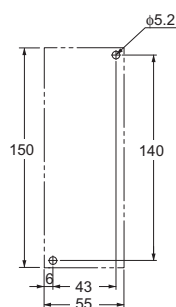

Single-phase/Three-phase 100VAC R88D-KN04L-ML2 (400W)

Single-phase/Three-phase 200VAC R88D-KN08H-ML2 (750W)

External dimensions

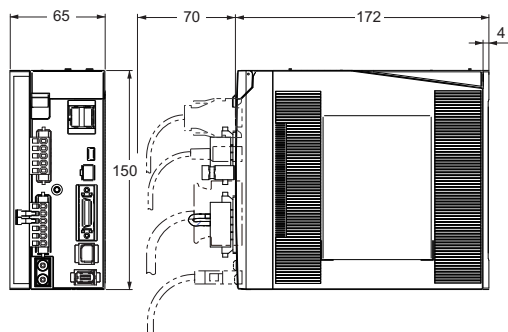

Mounting dimensions

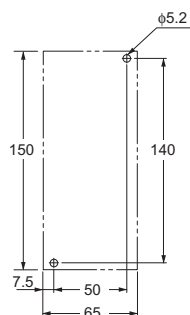

Single-phase/Three-phase 200VAC R88D-KN10H-ML2/-KN15H-ML2 (900 to 1.5kW)

External dimensions

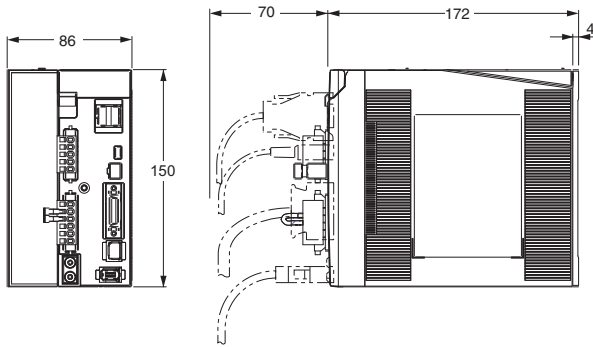

Mounting dimensions

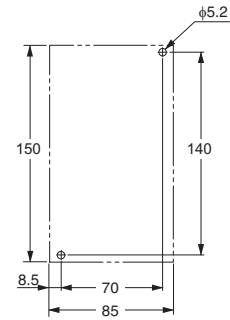

Three-phase 200VAC R88D-KN20H-ML2 (2kW)

External dimensions

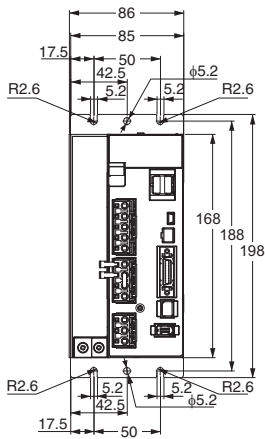

Mounting dimensions

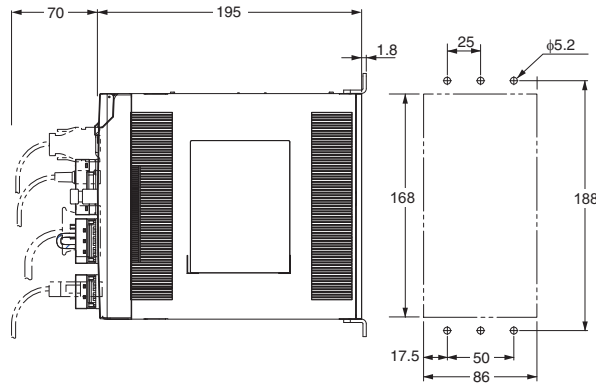

Three-phase 200VAC R88D-KN30H-ML2/-KN50H-ML2 (3 to 5kW)

External dimensions

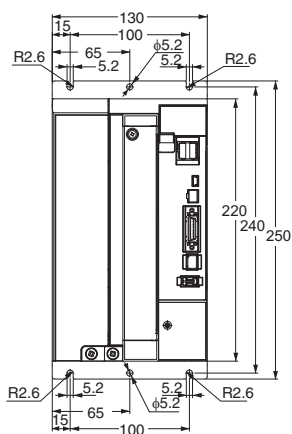

Mounting dimensions

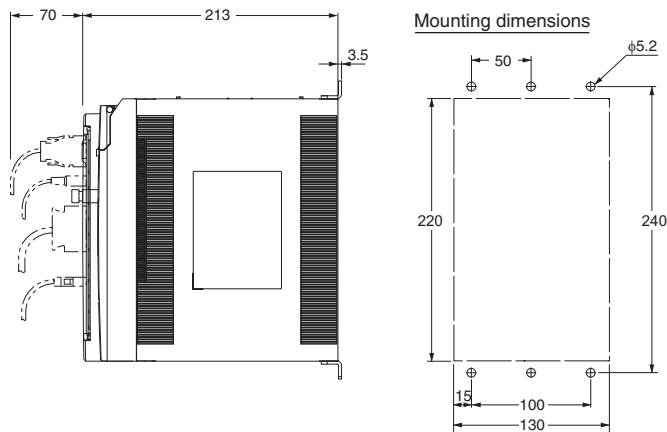

G5-Series
System Configuration

EtherCAT Communications
AC Servo Drive

EtherCAT Communications
Linear Motor Type
AC Servo Drive

General-purpose Inputs
AC Servo Drive

ML-II Type
AC Servo Drive

AC Servomotors

Linear Motor

**Three-phase 400VAC R88D-KN06F-ML2/-KN10F-ML2 (600 to 1.0kW)
Three-phase 400VAC R88D-KN15F-ML2 (1.5kW)**

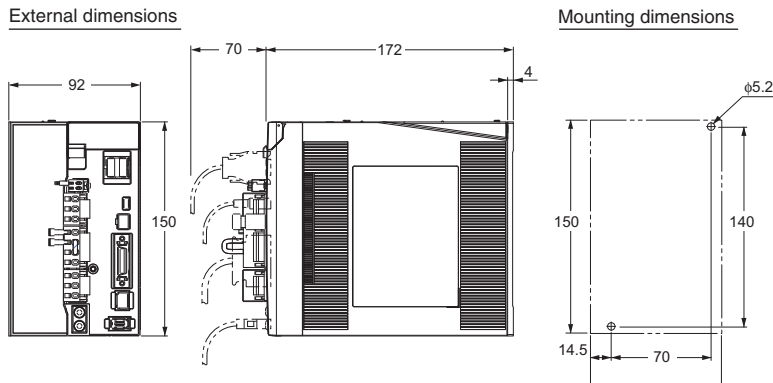

Three-phase 400VAC R88D-KN20F-ML2 (2kW)

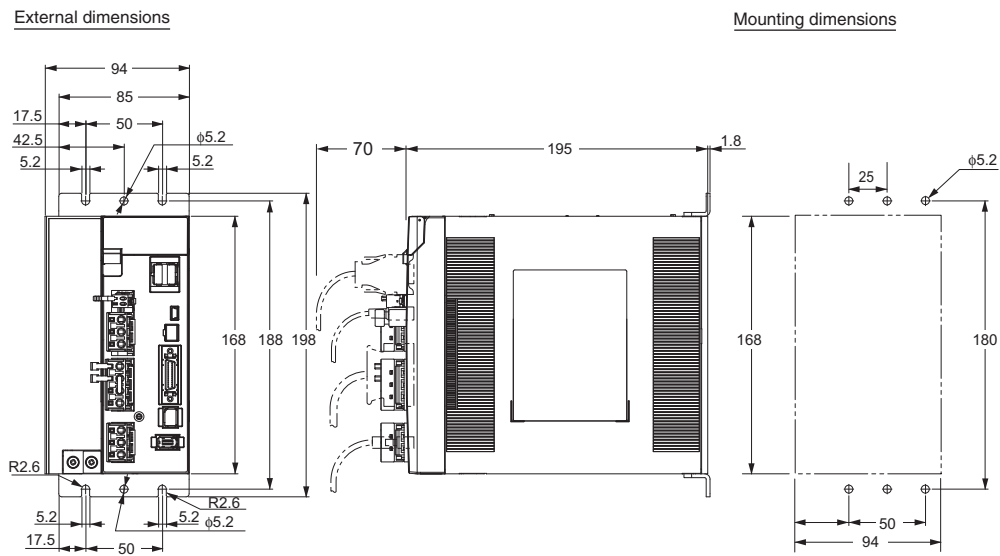

Three-phase 400VAC R88D-KN30F-ML2/-KN50F-ML2 (3 to 5kW)

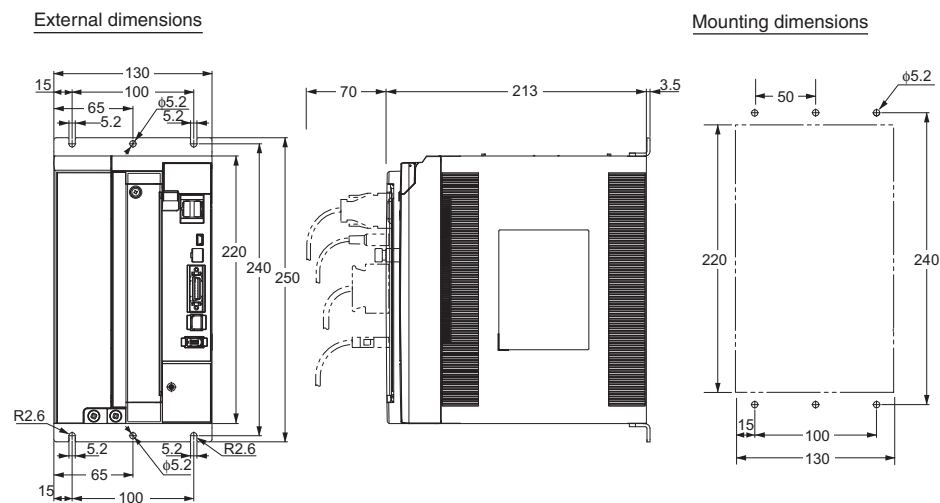

G5-series AC Servomotors

R88M-K INC ABS/INC

Contents

- Ordering Information
- Specifications
 - General Specifications
 - Characteristics/Torque and Rotation Speed Characteristics
 - <Cylinder type>
 - 3,000 r/min servomotors (100V, 200V, 400V)
 - 2,000 r/min servomotors (200V, 400V)
 - 1,500 r/min servomotors (200V/400V)
 - 1,000 r/min servomotors (200V/400V)
 - Encoder Specifications
- Dimensions



Ordering Information

Refer to the Ordering Information.

Specifications

General Specifications

Item	3,000-r/min motors		1,000-r/min motors 1,500-r/min motors 2,000-r/min motors
	50 to 750W	1 to 5kW	900 W to 15kW
Ambient operating temperature and operating humidity	0 to 40°C 20 to 85% RH (with no condensation)		
Storage ambient temperature and humidity	-20 to +65°C, 20% to 85% RH (with no condensation) Guaranteed maximum temperature: 72 hours at 80°C		
Operating and storage atmosphere	No corrosive gases		
Vibration resistance ^{*1}	Acceleration of 49 m/s ² 24.5 m/s ² max. in X, Y, and Z directions when the motor is stopped		
Impact resistance	Acceleration of 98 m/s ² max. 3 times each in X, Y, and Z directions		
Insulation resistance	Between power terminal and FG terminal: 20 MΩ min. (at 500 VDC Megger)		
Dielectric strength	1,500 VAC between power terminal and FG terminal (sensed current 10 mA) for 1 min (voltage 100 V, 200 V) 1,800 VAC between power terminal and FG terminal (sensed current 10 mA) for 1 min (voltage 400 V) 1,000 VAC between brake terminal and FG terminal (sensed current 10 mA) for 1 min		
Insulation class	Class B	Class F	
Protective structure	IP67 (except for through-shaft parts and motor and encoder connector pins)		
International standard	EC directive	Low voltage directive	EN60034-1/-5
	UL standards		UL1004-1
	CSA standards		CSA 22.2 No.100
			UL1004-1, UL1004-6 ^{*2}

*1. The amplitude may be amplified by machine resonance. Do not exceed 80% of the specified value for extended periods of time.

*2. UL 1004-6 applies only to 1,500-r/min Servomotors of 7.5 to 15 kW and 1,000-r/min Servomotors of 4.5 to 6 kW.

Note: 1. Do not use the cable when it is laying in oil or water.

Note: 2. Do not expose the cable outlet or connections to stress due to bending or the weight of the cable itself.

Note: 3. Always disconnect all connections to the Servo Motor before you perform insulation resistance tests on it. If you perform an insulation resistance test while the Servo Motor is connected, the Servo Motor may be damaged. Never perform dielectric strength tests on the Servo Motor. Failure to follow this precaution may result in damaging internal elements.

Note: 4. To conform EMC directive, the tips on wiring and installation written in the G5 series user's manual must be followed. Confirm the Manual No. that is listed in Related Manuals.

Characteristics/Torque and Rotation Speed Characteristics

Characteristics

<Cylinder type>

3,000 r/min Servomotors (100 VAC Input Power)

Model (R88M-)		K05030H	K10030L	K20030L	K40030L	
Item	Unit	K05030T	K10030S	K20030S	K40030S	
Rated output *1	W	50	100	200	400	
Rated torque *1	N • m	0.16	0.32	0.64	1.3	
Rated rotation speed	r/min	3,000				
Momentary maximum rotation speed	r/min	6,000				
Momentary maximum torque*1	N • m	0.48	0.95	1.91	3.8	
Rated current *1	A (rms)	1.1	1.6	2.5	4.6	
Momentary maximum current*1	A (0-p)	4.7	6.9	10.6	19.5	
Rotor inertia	Without brake	kg • m ²	0.025×10 ⁻⁴	0.051×10 ⁻⁴	0.14×10 ⁻⁴	0.26×10 ⁻⁴
	With brake	kg • m ²	0.027×10 ⁻⁴	0.054×10 ⁻⁴	0.16×10 ⁻⁴	0.28×10 ⁻⁴
Applicable load inertia	–	30 times the rotor inertia max. *2				
Torque constant *1	N • m/A	0.11±10%	0.14±10%	0.20±10%	0.21±10%	
Power rate *1	Without brake	kW/s	10.1	19.8	28.9	62.4
	With brake	kW/s	9.4	18.7	25.3	37.8
Mechanical time constant	Without brake	ms	1.43	1.03	0.61	0.48
	With brake	ms	1.54	1.09	0.70	0.52
Electrical time constant	ms	0.82	0.91	3.0	3.4	
Allowable radial load *3	N	68	68	245	245	
Allowable thrust load *3	N	58	58	98	98	
Weight	Without brake	kg	Approx. 0.31	Approx. 0.45	Approx. 0.78	Approx. 1.2
	With brake	kg	Approx. 0.51	Approx. 0.65	Approx. 1.2	Approx. 1.6
Radiator plate dimensions (material)		100×80×t10 (Al)		130×120×t12 (Al)		
Applicable drivers (R88D-)		KTA5L/KNA5L-ML2/ KNA5L-ECT	KT01L/KN01L-ML2/ KN01L-ECT	KT02L/KN02L-ML2/ KN02L-ECT	KT04L/KN04L-ML2/ KN04L-ECT	
Brake specifications	Brake inertia	kg • m ²	2×10 ⁻⁷	2×10 ⁻⁷	1.8×10 ⁻⁶	1.8×10 ⁻⁶
	Excitation voltage *4	V	24 VDC±10%			
	Power consumption (at 20°C)	W	7	7	9	9
	Current consumption (at 20°C)	A	0.3	0.3	0.36	0.36
	Static friction torque	N • m	0.29 min.	0.29 min.	1.27 min.	1.27 min.
	Attraction time *5	ms	35 max.	35 max.	50 max.	50 max.
	Release time *5	ms	20 max.	20 max.	15 max.	20 max.
	Backlash		±1°			
	Allowable work per braking	J	39.2	39.2	137	137
	Allowable total work	J	4.9×10 ³	4.9×10 ³	44.1×10 ³	44.1×10 ³
	Allowable angular acceleration	rad/s ²	30,000 max. (Speed of 2,800 r/min or more must not be changed in less than 10 ms)			
	Brake limit	–	10 million times min.			
	Rating	–	Continuous			
Insulation class	–	Type F				

*1. These are the values when the motor is combined with a driver at normal temperature (20°C, 65%). The momentary maximum torque indicates the standard value.

*2. Applicable load inertia.

- The operable load inertia ratio (load inertia/rotor inertia) depends on the mechanical configuration and its rigidity. For a machine with high rigidity, operation is possible even with high load inertia. Select an appropriate motor and confirm that operation is possible.
- If the dynamic brake is activated frequently with high load inertia, the Dynamic Brake Resistor may burn. Do not repeatedly turn the servo ON/OFF while the dynamic brake is enabled.
- The dynamic brake is designed only for emergency stops. Design the system so that the Servomotor remains stopped for at least 3 minutes after applying the dynamic brake. Otherwise the dynamic brake circuits may fail.

*3. The allowable radial and thrust loads are the values determined for a limit of 20,000 hours at normal operating temperatures. The allowable radial loads are applied as shown in the following diagram.

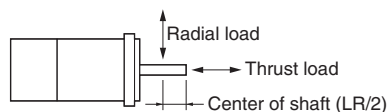

*4. This is a non-excitation brake. (It is released when excitation voltage is applied.)

*5. The operation time is the value (reference value) measured with a surge suppressor (CR50500 by Okaya Electric Industries Co., Ltd.).

Torque and Rotation Speed Characteristics 3,000 r/min Servomotors (100 VAC Input Power)

The following graphs show the characteristics with a 3-m standard cable and a 100 VAC input.

- R88M-K05030H/T (50W)

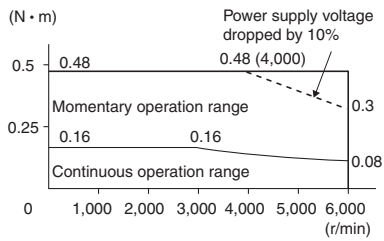

- R88M-K10030L/S (100W)

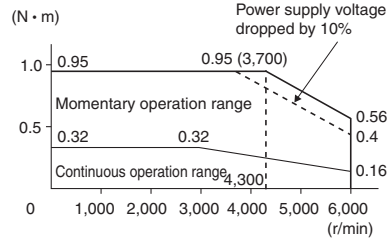

- R88M-K20030L/S (200W)

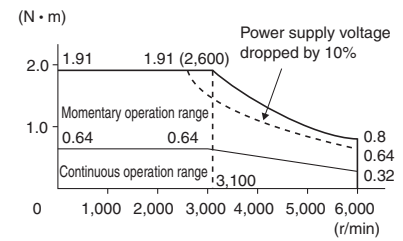

- R88M-K40030L/S (400W)

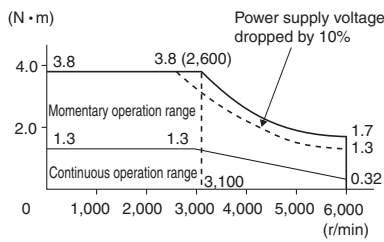

Note 1: The continuous operation range is the range in which continuous operation is possible. Continuous operation at the maximum speed is also possible. However, doing so will reduce the output torque.

Note 2: If the motor power cable exceeds 20 m, the voltage drop will increase and the momentary operation range will become narrower.

AC Servomotor/Drive G5-series

Characteristics

3,000 r/min Servomotors (200 VAC Input Power)

Model (R88M-)		K05030H	K10030H	K20030H	K40030H	K75030H	K1K030H	K1K530H	K2K030H	K3K030H	K4K030H	K5K030H		
Unit		K05030T	K10030T	K20030T	K40030T	K75030T	K1K030T	K1K530T	K2K030T	K3K030T	K4K030T	K5K030T		
Rated output *1	W	50	100	200	400	750	1000	1500	2000	3000	4000	5000		
Rated torque *1	N • m	0.16	0.32	0.64	1.3	2.4	3.18	4.77	6.37	9.55	12.7	15.9		
Rated rotation speed	r/min	3,000												
Momentary maximum rotation speed	r/min	6,000				5,000				4,500				
Momentary maximum torque *1	N • m	0.48	0.95	1.91	3.8	7.1	9.55	14.3	19.1	28.6	38.2	47.7		
Rated current *1	A (rms)	1.1	1.1	1.5	2.4	4.1	6.6	8.2	11.3	18.1	19.6	24.0		
Momentary maximum current *1	A (0-p)	4.7	4.7	6.5	10.2		28	35	48	77	83	102		
Rotor inertia	Without brake	kg • m ²	0.025×10 ⁻⁴	0.051×10 ⁻⁴	0.14×10 ⁻⁴	0.26×10 ⁻⁴	0.87×10 ⁻⁴	2.03×10 ⁻⁴	2.84×10 ⁻⁴	3.68×10 ⁻⁴	6.50×10 ⁻⁴	12.9×10 ⁻⁴	17.4×10 ⁻⁴	
	With brake	kg • m ²	0.027×10 ⁻⁴	0.054×10 ⁻⁴	0.16×10 ⁻⁴	0.28×10 ⁻⁴	0.97×10 ⁻⁴	2.35×10 ⁻⁴	3.17×10 ⁻⁴	4.01×10 ⁻⁴	7.85×10 ⁻⁴	14.2×10 ⁻⁴	18.6×10 ⁻⁴	
Applicable load inertia	–	30 times the rotor inertia max. *2					20 times the rotor inertia max. *2	15 times the rotor inertia max. *2		15 times the rotor inertia max. *2				
Torque constant *1	N • m/A	0.11±10%	0.21±10%	0.32±10%	0.40±10%	0.45±10%	0.37	0.45	0.44	0.41	0.49	0.49		
Power rate *1	Without brake	kW/s	10.1	19.8	28.9	62.3	65.4	49.8	80.1	110	140	126	146	
	With brake	kW/s	9.4	18.7	25.3	57.8	58.7	43.0	71.8	101	116	114	136	
Mechanical time constant	Without brake	ms	1.43	1.07	0.58	0.43	0.37	0.61	0.49	0.44	0.41	0.51	0.50	
	With brake	ms	1.54	1.13	0.66	0.46	0.42	0.71	0.55	0.48	0.49	0.56	0.54	
Electrical time constant	ms	0.82	0.90	3.2	3.4	5.3	5.8	6.3	6.7	11	12	13		
Allowable radial load *3	N	68	68	245	245	392	490	490	490	490	784	784		
Allowable thrust load *3	N	58	58	98	98	147	196	196	196	196	343	343		
Weight	Without brake	kg	Approx. 0.31	Approx. 0.46	Approx. 0.79	Approx. 1.2	Approx. 2.3	Approx. 3.5	Approx. 4.4	Approx. 5.3	Approx. 8.3	Approx. 11.0	Approx. 14.0	
	With brake	kg	Approx. 0.51	Approx. 0.66	Approx. 1.2	Approx. 1.6	Approx. 3.1	Approx. 4.5	Approx. 5.4	Approx. 6.3	Approx. 9.4	Approx. 12.6	Approx. 16.0	
Radiator plate dimensions (material)		100×80×t10 (Al)			130×120×t12 (Al)		170×160×t12 (Al)	320×300×t20 (Al)		380×350×t30 (Al)				
Applicable drives (R88D-)		KT01H/ KN01H- ML2/ KN01H- ECT	KT01H/ KN01H- ML2/ KN01H- ECT	KT02H/ KN02H- ML2/ KN02H- ECT	KT04H/ KN04H- ML2/ KN04H- ECT	KT08H/ KN08H- ML2/ KN08H- ECT	KT15H/ KN15H- ML2/ KN15H- ECT	KT15H/ KN15H- ML2/ KN15H- ECT	KT20H/ KN20H- ML2/ KN20H- ECT	KT30H/ KN30H- ML2/ KN30H- ECT	KT50H/ KN50H- ML2/ KN50H- ECT	KT50H/ KN50H- ML2/ KN50H- ECT		
Brake specifications	Brake inertia	kg • m ²	2×10 ⁻⁷	2×10 ⁻⁷	1.8×10 ⁻⁶	1.8×10 ⁻⁶	0.33×10 ⁻⁴	0.33×10 ⁻⁴	0.33×10 ⁻⁴	0.33×10 ⁻⁴	0.33×10 ⁻⁴	1.35×10 ⁻⁴	1.35×10 ⁻⁴	
	Excitation voltage *4	V	24 VDC±10%											
	Power consumption (at 20°C)	W	7	7	9	9	17	19	19	19	19	22	22	
	Current consumption (at 20°C)	A	0.3	0.3	0.36	0.36	0.70±10%	0.81±10%	0.81±10%	0.81±10%	0.81±10%	0.90±10%	0.90±10%	
	Static friction torque	N • m	0.29 min.	0.29 min.	1.27 min.	1.27 min.	2.5 min.	7.8 min.	7.8 min.	7.8 min.	11.8 min.	16.1 min.	16.1 min.	
	Attraction time *5	ms	35 max.	35 max.	50 max.	50 max.	50 max.	50 max.	50 max.	50 max.	80 max.	110 max.	110 max.	
	Release time *5	ms	20 max.	20 max.	15 max.	15 max.	15 max. *6	15 max. *6	15 max. *6	15 max. *6	15 max. *6	50 max. *6	50 max. *6	
	Backlash		±1°											
	Allowable work per braking	J	39.2	39.2	137	137	392	392	392	392	392	1470	1470	
	Allowable total work	J	4.9×10 ³	4.9×10 ³	44.1×10 ³	44.1×10 ³	4.9×10 ⁵	4.9×10 ⁵	4.9×10 ⁵	4.9×10 ⁵	4.9×10 ⁶	4.9×10 ⁶	2.2×10 ⁶	2.2×10 ⁶
	Allowable angular acceleration	rad/s ²	30,000 max. (Speed of 2,800 r/min or more must not be changed in less than 10 ms)					10,000						
	Brake limit	–	10 million times min.											
	Rating	–	Continuous											
Insulation class	–	Type F												

*1. These are the values when the motor is combined with a driver at normal temperature (20°C, 65%). The momentary maximum torque indicates the standard value.

*2. Applicable load inertia.

- The operable load inertia ratio (load inertia/rotor inertia) depends on the mechanical configuration and its rigidity. For a machine with high rigidity, operation is possible even with high load inertia. Select an appropriate motor and confirm that operation is possible.
- If the dynamic brake is activated frequently with high load inertia, the Dynamic Brake Resistor may burn. Do not repeatedly turn the servo ON/OFF while the dynamic brake is enabled.
- The dynamic brake is designed only for emergency stops. Design the system so that the Servomotor remains stopped for at least 3 minutes after applying the dynamic brake. Otherwise the dynamic brake circuits may fail.

*3. The allowable radial and thrust loads are the values determined for a limit of 20,000 hours at normal operating temperatures. The allowable radial loads are applied as shown in the following diagram.

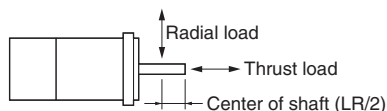

*4. This is a non-excitation brake. (It is released when excitation voltage is applied.)

*5. The operation time is the value (reference value) measured with a Spark Killer (CR50500 by Okaya Electric Industries Co., Ltd.).

*6. Direct current switching with a varistor (Z15D151 by SEMITEC Co.).

Torque and Rotation Speed Characteristics 3,000 r/min Servomotors (200 VAC Input Power)

The following graphs show the characteristics with a 3 m standard cable and a 200 VAC input.

• R88M-K05030H/T (50W)

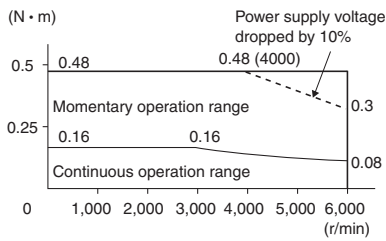

• R88M-K10030H/T (100W)

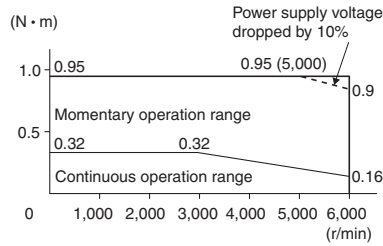

• R88M-K20030H/T (200W)

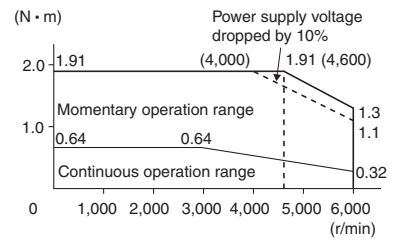

• R88M-K40030H/T (400W)

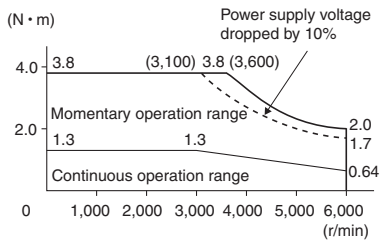

• R88M-K75030H/T (750W)

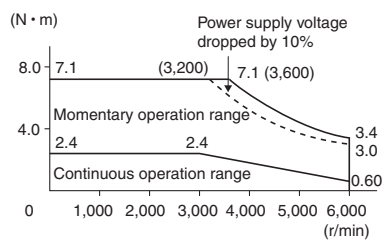

• R88M-K1K030H/T (1kW)

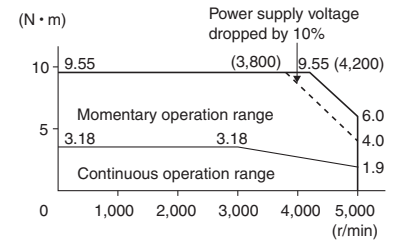

• R88M-K1K530H/T (1.5kW)

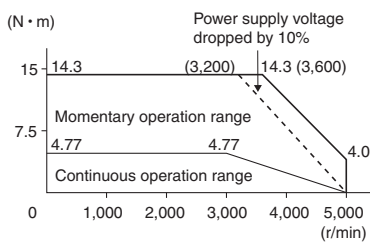

• R88M-K2K030H/T (2kW)

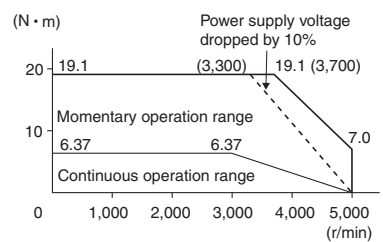

• R88M-K3K030H/T (3kW)

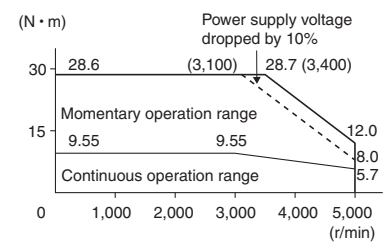

• R88M-K4K030H/T (4kW)

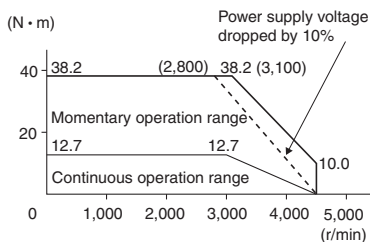

• R88M-K5K030H/T (5kW)

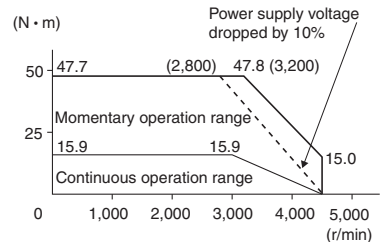

Note 1: The continuous operation range is the range in which continuous operation is possible. Continuous operation at the maximum speed is also possible. However, doing so will reduce the output torque.

Note 2: If the motor power cable exceeds 20 m, the voltage drop will increase and the momentary operation range will become narrower.

AC Servomotor/Drive G5-series

Characteristics

3,000 r/min Servomotors (400 VAC Input Power)

Item	Model (R88M-) Unit	K75030F	K1K030F	K1K530F	K2K030F	K3K030F	K4K030F	K5K030F	
		K75030C	K1K030C	K1K530C	K2K030C	K3K030C	K4K030C	K5K030C	
Rated output *1	W	750	1,000	1,500	2,000	3,000	4,000	5,000	
Rated torque *1	N • m	2.39	3.18	4.77	6.37	9.55	12.7	15.9	
Rated rotation speed	r/min	3,000							
Momentary maximum rotation speed	r/min	5,000					4,500		
Momentary maximum torque*1	N • m	7.16	9.55	14.3	19.1	28.6	38.2	47.7	
Rated current *1	A (rms)	2.4	3.3	4.2	5.7	9.2	9.9	12.0	
Momentary maximum current *1	A (0-p)	10	14	18	24	39	42	51	
Rotor inertia	Without brake	kg • m ²	1.61×10 ⁻⁴	2.03×10 ⁻⁴	2.84×10 ⁻⁴	3.68×10 ⁻⁴	6.50×10 ⁻⁴	12.9×10 ⁻⁴	17.4×10 ⁻⁴
	With brake	kg • m ²	1.93×10 ⁻⁴	2.35×10 ⁻⁴	3.17×10 ⁻⁴	4.01×10 ⁻⁴	7.85×10 ⁻⁴	14.2×10 ⁻⁴	18.6×10 ⁻⁴
Applicable load inertia	–	20 times the rotor inertia max. *2	15 times the rotor inertia max. *2						
Torque constant *1	N • m/A	0.78	0.75	0.89	0.87	0.81	0.98	0.98	
Power rate *1	Without brake	kW/s	35.5	49.8	80.1	110	140	126	146
	With brake	kW/s	29.6	43	71.8	101	116	114	136
Mechanical time constant	Without brake	ms	0.67	0.60	0.49	0.45	0.40	0.51	0.50
	With brake	ms	0.8	0.70	0.55	0.49	0.49	0.56	0.54
Electrical time constant	ms	5.9	5.8	6.5	6.6	12	13	13	
Allowable radial load *3	N	490	490	490	490	490	784	784	
Allowable thrust load *3	N	196	196	196	196	196	343	343	
Weight	Without brake	kg	Approx. 3.1	Approx. 3.5	Approx. 4.4	Approx. 5.3	Approx. 8.3	Approx. 11.0	Approx. 14.0
	With brake	kg	Approx. 4.1	Approx. 4.5	Approx. 5.4	Approx. 6.3	Approx. 9.4	Approx. 12.6	Approx. 16.0
Radiator plate dimensions (material)		320×300×t20 (Al)					380×350×t30 (Al)		
Applicable drives (R88D-)		KT10F/ KN10F-ML2/ KN10F-ECT	KT15F/ KN15F-ML2/ KN15F-ECT	KT15F/ KN15F-ML2/ KN15F-ECT	KT20F/ KN20F-ML2/ KN20F-ECT	KT30F/ KN30F-ML2/ KN30F-ECT	KT50F/ KN50F-ML2/ KN50F-ECT	KT50F/ KN50F-ML2/ KN50F-ECT	
Brake specifications	Brake inertia	kg • m ²	0.33×10 ⁻⁴	0.33×10 ⁻⁴	0.33×10 ⁻⁴	0.33×10 ⁻⁴	0.33×10 ⁻⁴	0.33×10 ⁻⁴	1.35×10 ⁻⁴
	Excitation voltage *4	V	24 VDC±10%						
	Power consumption (at 20°C)	W	17	19	19	19	19	22	22
	Current consumption (at 20°C)	A	0.70±10%	0.81±10%	0.81±10%	0.81±10%	0.81±10%	0.90±10%	0.90±10%
	Static friction torque	N • m	2.5 min.	7.8 min.	7.8 min.	7.8 min.	11.8 min.	16.1 min.	16.1 min.
	Attraction time *5	ms	50 max.	50 max.	50 max.	50 max.	80 max.	110 max.	110 max.
	Release time *5	ms	15 max. *6	15 max. *6	15 max. *6	15 max. *6	15 max. *6	50 max. *6	50 max. *6
	Backlash		±1°						
	Allowable work per braking	J	392	392	392	392	392	1470	1470
	Allowable total work	J	4.9×10 ⁵	4.9×10 ⁵	4.9×10 ⁵	4.9×10 ⁵	4.9×10 ⁵	2.2×10 ⁶	2.2×10 ⁶
	Allowable angular acceleration	rad/s ²	10,000						
	Brake limit	–	10 million times min.						
	Rating	–	Continuous						
Insulation class	–	Type F							

*1. These are the values when the motor is combined with a driver at normal temperature (20°C, 65%). The momentary maximum torque indicates the standard value.

*2. Applicable load inertia.

- The operable load inertia ratio (load inertia/rotor inertia) depends on the mechanical configuration and its rigidity. For a machine with high rigidity, operation is possible even with high load inertia. Select an appropriate motor and confirm that operation is possible.
- If the dynamic brake is activated frequently with high load inertia, the Dynamic Brake Resistor may burn. Do not repeatedly turn the servo ON/OFF while the dynamic brake is enabled.
- The dynamic brake is designed only for emergency stops. Design the system so that the Servomotor remains stopped for at least 3 minutes after applying the dynamic brake. Otherwise the dynamic brake circuits may fail.

*3. The allowable radial and thrust loads are the values determined for a limit of 20,000 hours at normal operating temperatures. The allowable radial loads are applied as shown in the following diagram.

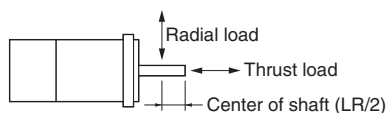

*4. This is a non-excitation brake. (It is released when excitation voltage is applied.)

*5. The operation time is the value (reference value) measured with a Spark Killer (CR50500 by Okaya Electric Industries Co., Ltd.).

*6. Direct current switching with a varistor (Z15D151 by SEMITEC Co.).

Torque and Rotation Speed Characteristics 3,000 r/min Servomotors (400 VAC Input Power)

The following graphs show the characteristics with a 3 m standard cable and a 400 VAC input.

- R88M-K75030F/C (750W)

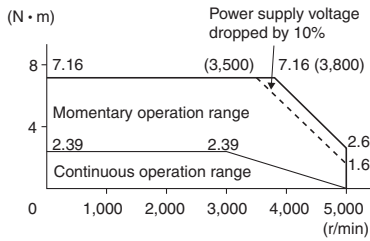

- R88M-K1K030F/C (1kW)

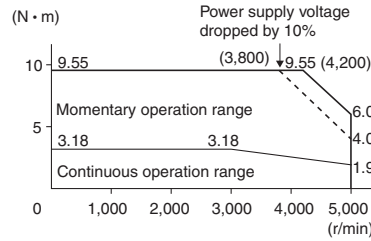

- R88M-K1K530F/C (1.5kW)

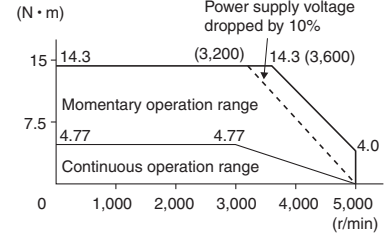

- R88M-K2K030F/C (2kW)

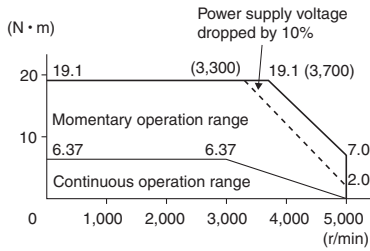

- R88M-K3K030F/C (3kW)

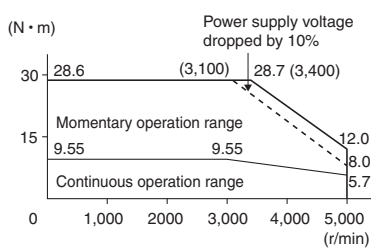

- R88M-K4K030F/C (4kW)

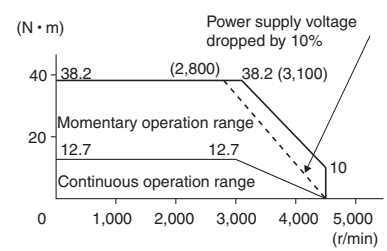

- R88M-K5K030F/C (5kW)

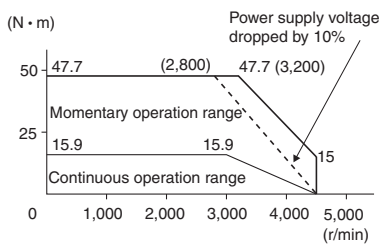

Note 1: The continuous operation range is the range in which continuous operation is possible. Continuous operation at the maximum speed is also possible. However, doing so will reduce the output torque.

Note 2: If the motor power cable exceeds 20 m, the voltage drop will increase and the momentary operation range will become narrower.

AC Servomotor/Drive G5-series

Characteristics

1,500 r/min, 2,000 r/min Servomotors (200 VAC Input Power)

Model (R88M-)		K1K020H	K1K520H	K2K020H	K3K020H	K4K020H	K5K020H	—	—	—	
Item	Unit	K1K020T	K1K520T	K2K020T	K3K020T	K4K020T	K5K020T	K7K515T	K11K015T	K15K015T	
Rated output *1	W	1,000	1,500	2,000	3,000	4,000	5,000	7,500	11,000	15,000	
Rated torque *1	N • m	4.77	7.16	9.55	14.3	19.1	23.9	47.8	70.0	95.0	
Rated rotation speed	r/min	2,000						1,500			
Momentary maximum rotation speed	r/min	3,000						3,000	2,000		
Momentary maximum torque *1	N • m	14.3	21.5	28.6	43.0	57.3	71.6	119.0	175.0	224.0	
Rated current *1	A (rms)	5.7	9.4	11.5	17.4	21.0	25.9	44.0	54.2	66.1	
Momentary maximum current *1	A (0-p)	24	40	49	74	89	110	165	203	236	
Rotor inertia	Without brake	kg • m ²	4.60×10 ⁻⁴	6.70×10 ⁻⁴	8.72×10 ⁻⁴	12.9×10 ⁻⁴	37.6×10 ⁻⁴	48.0×10 ⁻⁴	101×10 ⁻⁴	212×10 ⁻⁴	302×10 ⁻⁴
	With brake	kg • m ²	5.90×10 ⁻⁴	7.99×10 ⁻⁴	10.0×10 ⁻⁴	14.2×10 ⁻⁴	38.6×10 ⁻⁴	48.8×10 ⁻⁴	107×10 ⁻⁴	220×10 ⁻⁴	311×10 ⁻⁴
Applicable load inertia	—	10 times the rotor inertia max. *2									
Torque constant *1	N • m/A	0.63	0.58	0.64	0.59	0.70	0.70	0.77	0.92	1.05	
Power rate *1	Without brake	kW/s	49.5	76.5	105	159	97.1	119	226	231	302
	With brake	kW/s	38.6	64.2	91.2	144	94.5	117	213	223	293
Mechanical time constant	Without brake	ms	0.80	0.66	0.66	0.57	0.65	0.63	0.58	0.80	0.71
	With brake	ms	1.02	0.80	0.76	0.63	0.66	0.64	0.61	0.83	0.74
Electrical time constant	ms	9.4	10	10	12	20	19	21	31	32	
Allowable radial load *3	N	490	490	490	784	784	784	1,176	2,254	2,254	
Allowable thrust load *3	N	196	196	196	343	343	343	490	686	686	
Weight	Without brake	kg	Approx. 5.2	Approx. 6.7	Approx. 8.0	Approx. 11.0	Approx. 15.5	Approx. 18.6	Approx. 36.4	Approx. 52.7	Approx. 70.2
	With brake	kg	Approx. 6.7	Approx. 8.2	Approx. 9.5	Approx. 12.6	Approx. 18.7	Approx. 21.8	Approx. 40.4	Approx. 58.9	Approx. 76.3
Radiator plate dimensions (material)		275×260×t15 (Al)			380×350×t30 (Al)	470×440×t30 (Al)		550×520×t30 (Al)	670×630×t35 (Al)		
Applicable drives (R88D-)		KT10H/ KN10H- ML2/ KN10H- ECT	KT15H/ KN15H- ML2/ KN15H- ECT	KT20H/ KN20H- ML2/ KN20H- ECT	KT30H/ KN30H- ML2/ KN30H- ECT	KT50H/ KN50H- ML2/ KN50H- ECT	KT50H/ KN50H- ML2/ KN50H- ECT	KT75H/ KN75H- ECT	KT150H/ KN150H- ECT	KT150H/ KN150H- ECT	
Brake specifications	Brake inertia	kg • m ²	1.35×10 ⁻⁴	1.35×10 ⁻⁴	1.35×10 ⁻⁴	1.35×10 ⁻⁴	4.7×10 ⁻⁴	4.7×10 ⁻⁴	4.7×10 ⁻⁴	7.1×10 ⁻⁴	7.1×10 ⁻⁴
	Excitation voltage *4	V	24 VDC±10%								
	Power consumption (at 20°C)	W	14	19	19	22	31	31	34	26	26
	Current consumption (at 20°C)	A	0.59±10%	0.79±10%	0.79±10%	0.90±10%	1.3±10%	1.3±10%	1.4±10%	1.08±10%	1.08±10%
	Static friction torque	N • m	4.9 min.	13.7 min.	13.7 min.	16.2 min.	24.5 min.	24.5 min.	58.8 min.	100 min.	100 min.
	Attraction time *5	ms	80 max.	100 max.	100 max.	110 max.	80 max.	80 max.	150 max.	300 max.	300 max.
	Release time *5	ms	70 max. *6	50 max. *6	50 max. *6	50 max. *6	25 max. *6	25 max. *6	50 max.	140 max.	140 max.
	Backlash		±1°								
	Allowable work per braking	J	588	1,176	1,176	1,470	1,372	1,372	1,372	2,000	2,000
	Allowable total work	J	7.8×10 ⁵	1.5×10 ⁶	1.5×10 ⁶	2.2×10 ⁶	2.9×10 ⁶	2.9×10 ⁶	2.9×10 ⁶	4.0×10 ⁶	4.0×10 ⁶
	Allowable angular acceleration	rad/s ²	10,000						5,000	3,000	
	Brake limit	—	10 million times min.								
Rating	—	Continuous									
Insulation class	—	Type F									

*1. These are the values when the motor is combined with a driver at normal temperature (20°C, 65%). The momentary maximum torque indicates the standard value.

*2. Applicable load inertia.

- The operable load inertia ratio (load inertia/rotor inertia) depends on the mechanical configuration and its rigidity. For a machine with high rigidity, operation is possible even with high load inertia. Select an appropriate motor and confirm that operation is possible.
- If the dynamic brake is activated frequently with high load inertia, the Dynamic Brake Resistor may burn. Do not repeatedly turn the servo ON/OFF while the dynamic brake is enabled.
- The dynamic brake is designed only for emergency stops. Design the system so that the Servomotor remains stopped for at least 3 minutes after applying the dynamic brake. Otherwise the dynamic brake circuits may fail.

*3. The allowable radial and thrust loads are the values determined for a limit of 20,000 hours at normal operating temperatures. The allowable radial loads are applied as shown in the following diagram.

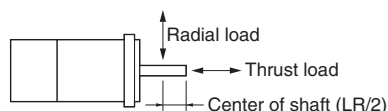

*4. This is a non-excitation brake. (It is released when excitation voltage is applied.)

*5. The operation time is the value (reference value) measured with a Spark Killer (CR50500 by Okaya Electric Industries Co., Ltd.).

*6. Direct current switching with a varistor (Z15D151 by SEMITEC Co.).

Torque and Rotation Speed Characteristics

1,500 r/min, 2,000 r/min Servomotors (200 VAC Input Power)

The following graphs show the characteristics with a 3 m standard cable and a 200 VAC input.

- R88M-K1K020H/T (1kW)

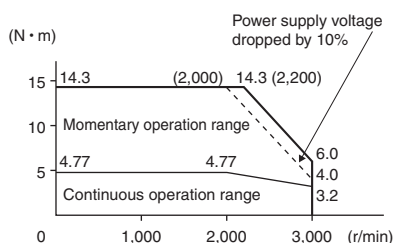

- R88M-K1K520H/T (1.5kW)

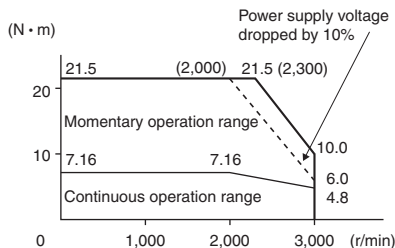

- R88M-K2K020H/T (2kW)

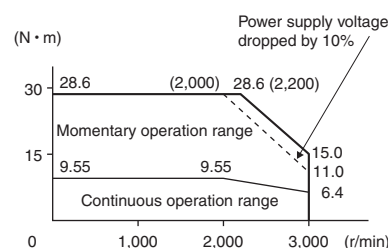

- R88M-K3K020H/T (3kW)

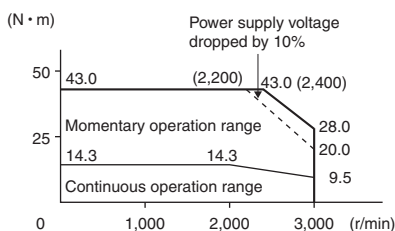

- R88M-K4K020H/T (4kW)

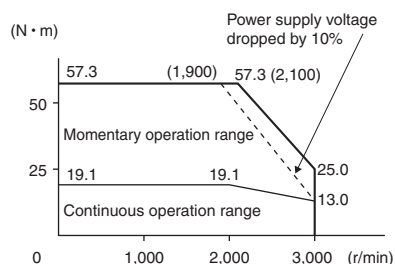

- R88M-K5K020H/T (5kW)

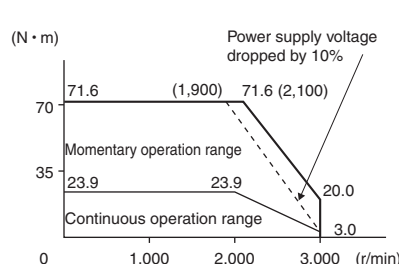

- R88M-K7K515T (7.5kW)

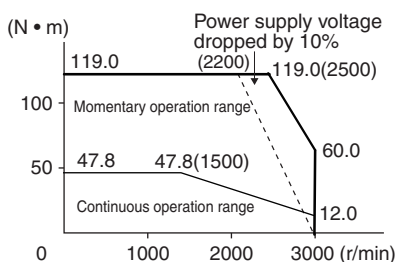

- R88M-K11K015T (11kW)

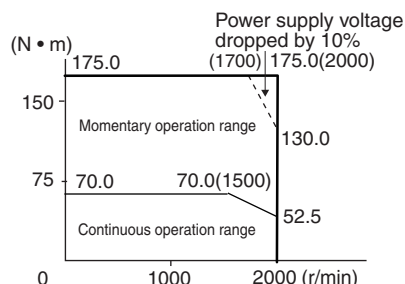

- R88M-K15K015T (15kW)

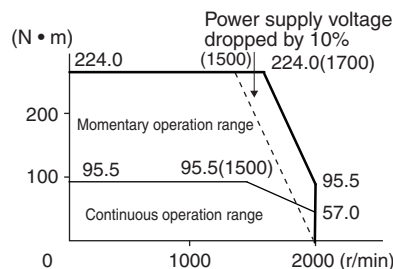

Note 1: The continuous operation range is the range in which continuous operation is possible. Continuous operation at the maximum speed is also possible. However, doing so will reduce the output torque.

Note 2: If the motor power cable exceeds 20 m, the voltage drop will increase and the momentary operation range will become narrower.

AC Servomotor/Drive G5-series

Characteristics

1,500 r/min, 2,000 r/min Servomotors (400 VAC Input Power)

Model (R88M-)		K40020F	K60020F	K1K020F	K1K520F	K2K020F	K3K020F	K4K020F	K5K020F	—	—	—		
Item		Unit	K40020C	K60020C	K1K020C	K1K520C	K2K020C	K3K020C	K4K020C	K5K020C	K7K515C	K11K015C	K15K015C	
Rated output *1		W	400	600	1,000	1,500	2,000	3,000	4,000	5,000	7,500	11,000	15,000	
Rated torque *1		N • m	1.91	2.86	4.77	7.16	9.55	14.3	19.1	23.9	47.8	70.0	95.9	
Rated rotation speed		r/min	2,000									1,500		
Momentary maximum rotation speed		r/min	3,000									2,000		
Momentary maximum torque *1		N • m	5.73	8.59	14.3	21.5	28.7	43.0	57.3	71.6	119.0	175.0	224.0	
Rated current *1		A (rms)	1.2	1.5	2.8	4.7	5.9	8.7	10.6	13.0	22.0	27.1	33.1	
Momentary maximum current *1		A (0-p)	4.9	6.5	12	20	25	37	45	55	83	101	118	
Rotor inertia	Without brake	kg • m ²	1.61×10 ⁻⁴	2.03×10 ⁻⁴	4.60×10 ⁻⁴	6.70×10 ⁻⁴	8.72×10 ⁻⁴	12.9×10 ⁻⁴	37.6×10 ⁻⁴	48.0×10 ⁻⁴	101×10 ⁻⁴	212×10 ⁻⁴	302×10 ⁻⁴	
	With brake	kg • m ²	1.90×10 ⁻⁴	2.35×10 ⁻⁴	5.90×10 ⁻⁴	7.99×10 ⁻⁴	10.0×10 ⁻⁴	14.2×10 ⁻⁴	38.6×10 ⁻⁴	48.8×10 ⁻⁴	107×10 ⁻⁴	220×10 ⁻⁴	311×10 ⁻⁴	
Applicable load inertia		—	10 times the rotor inertia max. *2											
Torque constant *1		N • m/A	1.27	1.38	1.27	1.16	1.27	1.18	1.40	1.46	1.54	1.84	2.10	
Power rate *1	Without brake	kW/s	22.7	40.3	49.5	76.5	105	159	97.1	119	226	231	302	
	With brake	kW/s	19.2	34.8	38.6	64.2	91.2	144	94.5	117	213	223	293	
Mechanical time constant	Without brake	ms	0.70	0.62	0.79	0.66	0.68	0.56	0.60	0.60	0.58	0.80	0.71	
	With brake	ms	0.83	0.72	1.01	0.79	0.78	0.61	0.61	0.61	0.61	0.83	0.74	
Electrical time constant		ms	5.7	5.9	10	10	10	12	21	19	21	31	32	
Allowable radial load *3		N	490	490	490	490	490	784	784	784	1,176	2,254	2,254	
Allowable thrust load *3		N	196	196	196	196	196	343	343	343	490	686	686	
Weight	Without brake	kg	Approx. 3.1	Approx. 3.5	Approx. 5.2	Approx. 6.7	Approx. 8.0	Approx. 11.0	Approx. 15.5	Approx. 18.6	Approx. 36.4	Approx. 52.7	Approx. 70.2	
	With brake	kg	Approx. 4.1	Approx. 4.5	Approx. 6.7	Approx. 8.2	Approx. 9.5	Approx. 12.6	Approx. 18.7	Approx. 21.8	Approx. 40.4	Approx. 58.9	Approx. 76.3	
Radiator plate dimensions (material)			320×300×t20 (Al)			275×260×t15 (Al)			380×350×t30 (Al)	470×440×t30 (Al)		550×520×t30 (Al)	670×630×t35 (Al)	
Applicable drives (R88D-)			KT06F/ KN06F- ML2/ KN06F- ECT	KT06F/ KN06F- ML2/ KN06F- ECT	KT10F/ KN10F- ML2/ KN10F- ECT	KT15F/ KN15F- ML2/ KN15F- ECT	KT20F/ KN20F- ML2/ KN20F- ECT	KT30F/ KN30F- ML2/ KN30F- ECT	KT50F/ KN50F- ML2/ KN50F- ECT	KT50F/ KN50F- ML2/ KN50F- ECT	KT75F/ KN75F- ECT	KT150F/ KN150F- ECT	KT150F/ KN150F- ECT	
Brake specifications	Brake inertia	kg • m ²	1.35×10 ⁻⁴	1.35×10 ⁻⁴	1.35×10 ⁻⁴	1.35×10 ⁻⁴	1.35×10 ⁻⁴	1.35×10 ⁻⁴	4.7×10 ⁻⁴	4.7×10 ⁻⁴	4.7×10 ⁻⁴	7.1×10 ⁻⁴	7.1×10 ⁻⁴	
	Excitation voltage *4	V	24 VDC±10%											
	Power consumption (at 20°C)	W	17	17	14	19	19	22	31	31	34	26	26	
	Current consumption (at 20°C)	A	0.70±10%	0.70±10%	0.59±10%	0.79±10%	0.79±10%	0.90±10%	1.3±10%	1.3±10%	1.4±10%	1.08±10%	1.08±10%	
	Static friction torque	N • m	2.5 min.	2.5 min.	4.9 min.	13.7 min.	13.7 min.	16.2 min.	24.5 min.	24.5 min.	58.8 min.	100 min.	100 min.	
	Attraction time *5	ms	50 max.	50 max.	80 max.	100 max.	100 max.	110 max.	80 max.	80 max.	150 max.	300 max.	300 max.	
	Release time *5	ms	15 max. *7	15 max. *7	70 max. *6	50 max. *6	50 max. *6	50 max. *6	25 max. *6	25 max. *6	50 max.	140 max.	140 max.	
	Backlash		±1°											
	Allowable work per braking	J	392	392	588	1,176	1,176	1,470	1,372	1,372	1,372	1,372	2,000	2,000
	Allowable total work	J	4.9×10 ⁵	4.9×10 ⁵	7.8×10 ⁵	1.5×10 ⁶	1.5×10 ⁶	2.2×10 ⁶	2.9×10 ⁶	2.9×10 ⁶	2.9×10 ⁶	2.9×10 ⁶	4.0×10 ⁶	4.0×10 ⁶
	Allowable angular acceleration	rad/s ²	10,000									5,000	3,000	
	Brake limit	—	10 million times min.											
	Rating	—	Continuous											
Insulation class	—	Type F												

*1. These are the values when the motor is combined with a driver at normal temperature (20°C, 65%). The momentary maximum torque indicates the standard value.

*2. Applicable load inertia.

- The operable load inertia ratio (load inertia/rotor inertia) depends on the mechanical configuration and its rigidity. For a machine with high rigidity, operation is possible even with high load inertia. Select an appropriate motor and confirm that operation is possible.
- If the dynamic brake is activated frequently with high load inertia, the Dynamic Brake Resistor may burn. Do not repeatedly turn the servo ON/OFF while the dynamic brake is enabled.
- The dynamic brake is designed only for emergency stops. Design the system so that the Servomotor remains stopped for at least 3 minutes after applying the dynamic brake. Otherwise the dynamic brake circuits may fail.

*3. The allowable radial and thrust loads are the values determined for a limit of 20,000 hours at normal operating temperatures. The allowable radial loads are applied as shown in the following diagram.

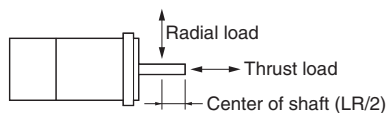

*4. This is a non-excitation brake. (It is released when excitation voltage is applied.)

*5. The operation time is the value (reference value) measured with a Spark Killer (CR5050 by Okaya Electric Industries Co., Ltd.).

*6. Direct current switching with a varistor (Z15D151 by SEMITEC Co.).

Torque and Rotation Speed Characteristics

1,500 r/min, 2,000 r/min Servomotors (400 VAC Input Power)

The following graphs show the characteristics with a 3 m standard cable and a 400 VAC input.

- R88M-K40020F/C (400W)

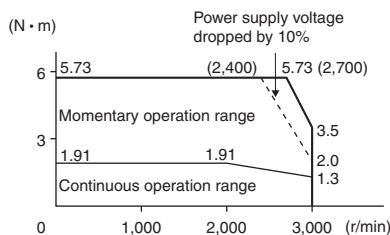

- R88M-K60020F/C (600W)

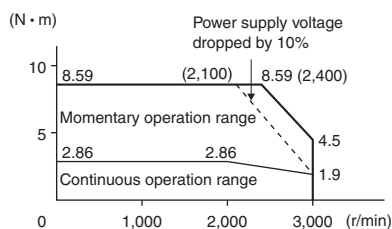

- R88M-K1K020F/C (1kW)

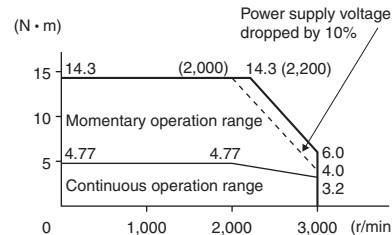

- R88M-K1K520F/C (1.5kW)

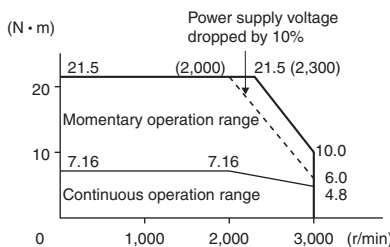

- R88M-K2K020F/C (2kW)

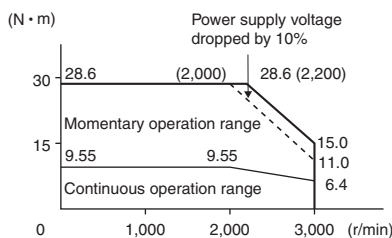

- R88M-K3K020F/C (3kW)

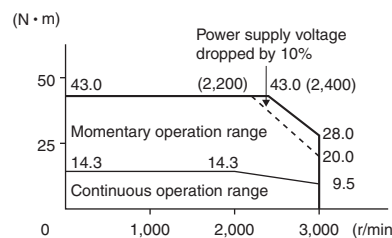

- R88M-K4K020F/C (4kW)

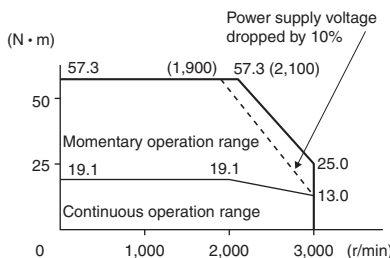

- R88M-K5K020F/C (5kW)

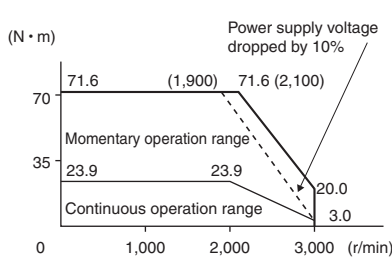

- R88M-K7K515C (7.5kW)

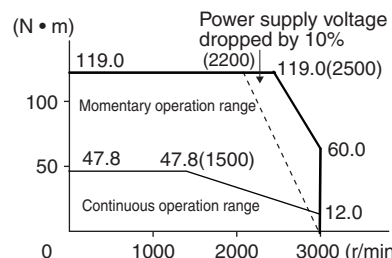

- R88M-K11K015C (11kW)

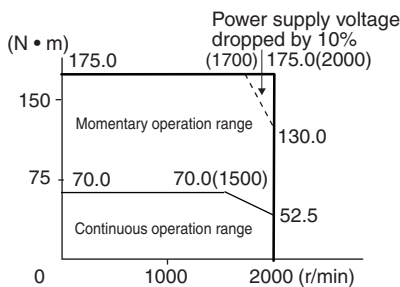

- R88M-K15K015C (15kW)

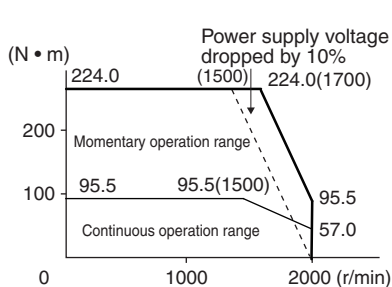

Note 1: The continuous operation range is the range in which continuous operation is possible. Continuous operation at the maximum speed is also possible. However, doing so will reduce the output torque.

Note 2: If the motor power cable exceeds 20 m, the voltage drop will increase and the momentary operation range will become narrower.

AC Servomotor/Drive G5-series

Characteristics

1,000 r/min Servomotors (200/400 VAC Input Power)

Model (R88M-)		200 VAC					400 VAC					
		K90010H	K2K010H	K3K010H	–	–	K90010F	K2K010F	K3K010F	–	–	
Item	Unit	K90010T	K2K010T	K3K010T	K4K510T	K6K010T	K90010C	K2K010C	K3K010C	K4K510C	K6K010C	
Rated output *1	W	900	2,000	3,000	4,500	6,000	900	2,000	3,000	4,500	6,000	
Rated torque *1	N • m	8.59	19.1	28.7	43.0	57.0	8.59	19.1	28.7	43.0	57.3	
Rated rotation speed	r/min	1,000										
Momentary maximum rotation speed	r/min	2,000										
Momentary maximum torque *1	N • m	19.3	47.7	71.7	107.0	143.0	19.3	47.7	71.7	107.0	143.0	
Rated current *1	A (rms)	7.6	17.0	22.6	29.7	38.8	3.8	8.5	11.3	14.8	19.4	
Momentary maximum current *1	A (0-p)	24	60	80	110	149	12	30	40	55	74	
Rotor inertia	Without brake	kW/s	6.70×10 ⁻⁴	30.3×10 ⁻⁴	48.4×10 ⁻⁴	79.1×10 ⁻⁴	101×10 ⁻⁴	6.70×10 ⁻⁴	30.3×10 ⁻⁴	48.4×10 ⁻⁴	79.1×10 ⁻⁴	101×10 ⁻⁴
	With brake	kW/s	7.99×10 ⁻⁴	31.4×10 ⁻⁴	49.2×10 ⁻⁴	84.4×10 ⁻⁴	107×10 ⁻⁴	7.99×10 ⁻⁴	31.4×10 ⁻⁴	49.2×10 ⁻⁴	84.4×10 ⁻⁴	107×10 ⁻⁴
Applicable load inertia	–	10 times the rotor inertia max. *2										
Torque constant *1	N • m/A	0.86	0.88	0.96	1.02	1.04	1.72	1.76	1.92	2.05	2.08	
Power rate *1	Without brake	kW/s	110	120	170	233	325	110	120	170	233	325
	With brake	kW/s	92.4	116	167	219	307	92.4	116	167	219	307
Mechanical time constant	Without brake	ms	0.66	0.75	0.63	0.55	0.54	0.66	0.76	0.61	0.55	0.54
	With brake	ms	0.78	0.78	0.64	0.63	0.57	0.79	0.78	0.62	0.63	0.57
Electrical time constant	ms	11	18	21	20	23	11	18	22	20	23	
Allowable radial load *3	N	686	1176	1470	1470	1764	686	1176	1470	1470	1764	
Allowable thrust load *3	N	196	490	490	490	588	196	490	490	490	588	
Weight	Without brake	kg	Approx. 6.7	Approx. 14.0	Approx. 20.0	Approx. 29.4	Approx. 36.4	Approx. 6.7	Approx. 14.0	Approx. 20.0	Approx. 29.4	Approx. 36.4
	With brake	kg	Approx. 8.2	Approx. 17.5	Approx. 23.5	Approx. 33.3	Approx. 40.4	Approx. 8.2	Approx. 17.5	Approx. 23.5	Approx. 33.3	Approx. 40.4
Radiator plate dimensions (material)		270×260×115 (Al)			470×440×t30 (Al)	550×520×t30 (Al)	270×260×t15 (Al)	470×440×t30 (Al)			550×520×t30 (Al)	
Applicable drives (R88D-)		KT15H/ KN15H- ML2/ KN15H- ECT	KT30H/ KN30H- ML2/ KN30HF- ECT	KT50H/ KN50H- ML2/ KN50H- ECT	KT50H/ KN50H- ECT	KT75H/ KN75H- ECT	KT15F/ KN15F- ML2/ KN15F- ECT	KT30F/ KN30F- ML2/ KN30F- ECT	KT50F/ KN50F- ML2/ KN50F- ECT	KT50F/ KN50F- ECT	KT75F/ KN75F- ECT	
Brake specifications	Brake inertia	kg • m ²	1.35×10 ⁻⁴	4.7×10 ⁻⁴	4.7×10 ⁻⁴	4.7×10 ⁻⁴	4.7×10 ⁻⁴	1.35×10 ⁻⁴	4.7×10 ⁻⁴	4.7×10 ⁻⁴	4.7×10 ⁻⁴	4.7×10 ⁻⁴
	Excitation voltage *4	V	24 VDC±10%									
	Power consumption (at 20°C)	W	19	31	34	34	34	19	31	34	34	34
	Current consumption (at 20°C)	A	0.79±10%	1.3±10%	1.4±10%	1.4±10%	1.4±10%	0.79±10%	1.3±10%	1.4±10%	1.4±10%	1.4±10%
	Static friction torque	N • m	13.7 min.	24.5 min.	58.8 min.	58.8 min.	58.8 min.	13.7 min.	24.5 min.	58.8 min.	58.8 min.	58.8 min.
	Attraction time *5	ms	100 max.	80 max.	150 max.	150 max.	150 max.	100 max.	80 max.	150 max.	150 max.	150 max.
	Release time *5	ms	50 max. *6	25 max. *7	50 max. *7	50 max.	50 max.	50 max. *6	25 max. *6	50 max. *6	50 max.	50 max.
	Backlash		±1°									
	Allowable work per braking	J	1,176	1,372	1,372	1,372	1,372	1,176	1,372	1,372	1,372	1,372
	Allowable total work	J	1.5×10 ⁶	2.9×10 ⁶	2.9×10 ⁶	2.9×10 ⁶	2.9×10 ⁶	1.5×10 ⁶	2.9×10 ⁶	2.9×10 ⁶	2.9×10 ⁶	2.9×10 ⁶
	Allowable angular acceleration	rad/s ²	10,000			5,000		10,000			5,000	
	Brake limit	–	10 million times min.									
Rating	–	Continuous										
Insulation class	–	Type F										

*1. These are the values when the motor is combined with a driver at normal temperature (20°C, 65%). The momentary maximum torque indicates the standard value.

*2. Applicable load inertia.

- The operable load inertia ratio (load inertia/rotor inertia) depends on the mechanical configuration and its rigidity. For a machine with high rigidity, operation is possible even with high load inertia. Select an appropriate motor and confirm that operation is possible.
- If the dynamic brake is activated frequently with high load inertia, the Dynamic Brake Resistor may burn. Do not repeatedly turn the servo ON/OFF while the dynamic brake is enabled.
- The dynamic brake is designed only for emergency stops. Design the system so that the Servomotor remains stopped for at least 3 minutes after applying the dynamic brake. Otherwise the dynamic brake circuits may fail.

*3. The allowable radial and thrust loads are the values determined for a limit of 20,000 hours at normal operating temperatures. The allowable radial loads are applied as shown in the following diagram.

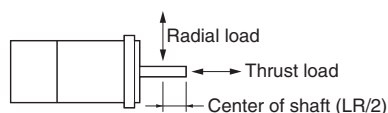

*4. This is a non-excitation brake. (It is released when excitation voltage is applied.)

*5. The operation time is the value (reference value) measured with a Spark Killer (CR50500 by Okaya Electric Industries Co., Ltd.).

*6. Direct current switching with a varistor (Z15D151 by SEMITEC Co.).

Torque and Rotation Speed Characteristics 1,000 r/min Servomotors (200/400 VAC Input Power)

The following graphs show the characteristics with a 3 m standard cable and a 200 VAC input.

- R88M-K90010H/T/F/C (900W)

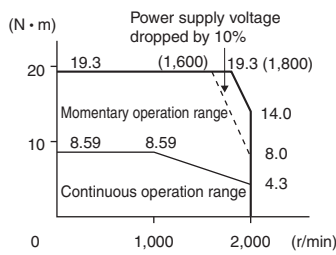

- R88M-K2K010H/T/F/C (2kW)

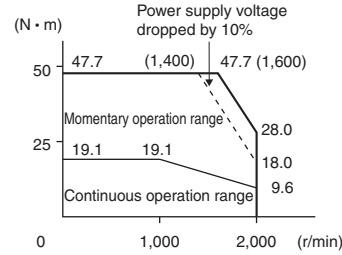

- R88M-K3K010H/T/F/C (3kW)

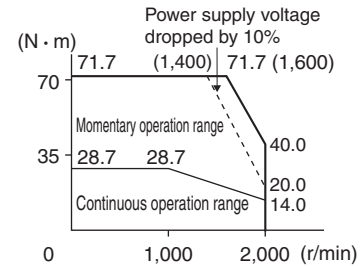

- R88M-K4K510T/C (4.5kW)

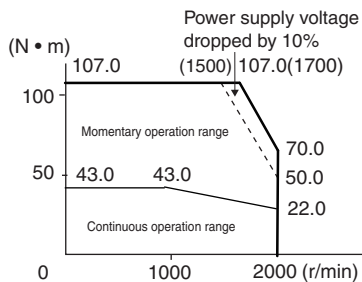

- R88M-K6K010T/C (6kW)

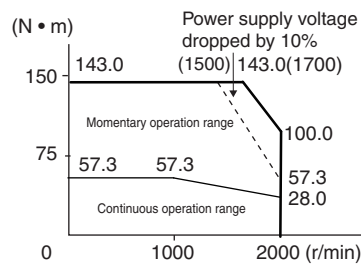

Note 1: The continuous operation range is the range in which continuous operation is possible. Continuous operation at the maximum speed is also possible. However, doing so will reduce the output torque.

Note 2: If the motor power cable exceeds 20 m, the voltage drop will increase and the momentary operation range will become narrower.

Encoder Specifications

Incremental Encoders

Item	Specifications
Encoder system	Optical encoder 20 bits
No. of output pulses	Phases A and B: 262,144 pulses/rotation Phase Z: 1 pulse/rotation
Power supply voltage	5 VDC±5%
Power supply current	180 mA (max.)
Output signals	+S, -S
Output interface	RS-485 compliance

Absolute Encoders

Item	Specifications
Encoder system	Optical encoder 17 bits
No. of output pulses	Phases A and B: 32,768 pulses/rotation Phase Z: 1 pulse/rotation
Maximum rotations	-32,768 to +32,767 rotations
Power supply voltage	5 VDC±5%
Power supply current	110 mA (max.)
Applicable battery voltage	3.6 VDC
Current consumption of battery	265 μA for a maximum of 5 s right after power interruption 100 μA for operation during power interruption 3.6 μA when power is supplied to Servo Drive
Output signals	+S, -S
Output interface	RS-485 compliance

Note: Multi-rotation Data Backup

- The multi-rotation data will be lost if the battery cable connector is disconnected at the motor when connecting the battery cable for the absolute encoder and battery.
- The multi-rotation data will be lost if CN2 is disconnected when connecting the battery to CN1 without the use of a battery cable for the absolute encoder.

G5-Series
System Configuration

EtherCAT Communications
AC Servo Drive

EtherCAT Communications
Linear Motor Type
AC Servo Drive

General-purpose Inputs
AC Servo Drive

ML-II Type
AC Servo Drive

AC Servomotors

Linear Motor

AC Servomotor/Drive G5-series

Dimensions

<Cylinder type>

3,000 r/min Servomotors (100/200 VAC)

50W/100W

• Without brake

- R88M-K05030H (-S2)/-K10030□ (-S2) **INC**
- R88M-K05030T (-S2)/-K10030□ (-S2) **ABS**

Model	Dimensions (mm)		
	LL	LM	LN
R88M-K05030□	72	48	23
R88M-K10030□	92	68	43

CAD data

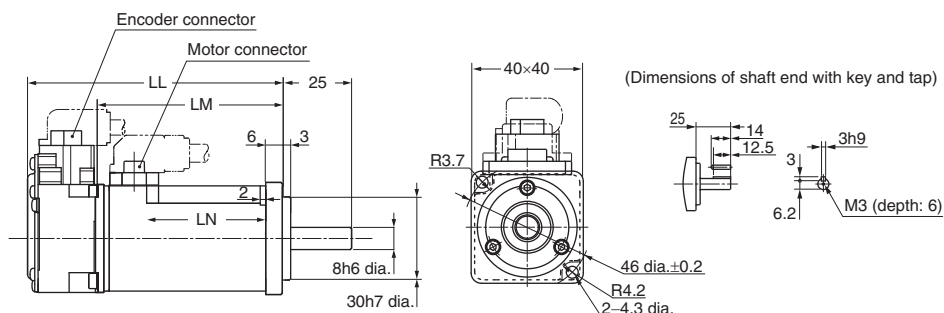

• With brake

- R88M-K05030H-B (S2)/-K10030□-B (S2) **INC**
- R88M-K05030T-B (S2)/-K10030□-B (S2) **ABS**

Model	Dimensions (mm)		
	LL	LM	LN
R88M-K05030□-B□	102	78	23
R88M-K10030□-B□	122	98	43

CAD data

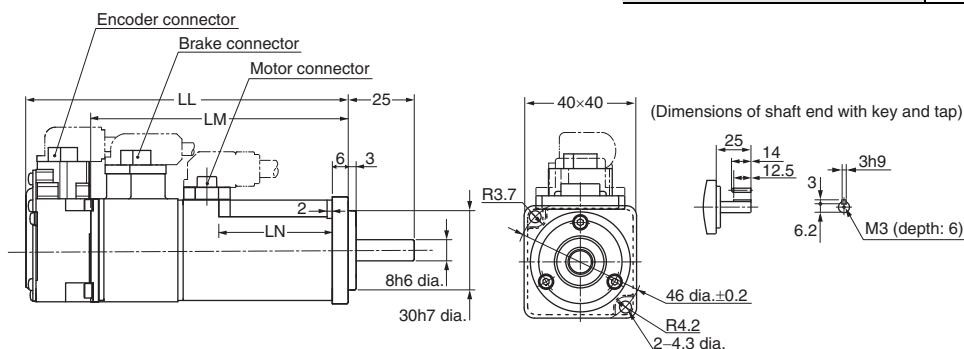

200W/400W

• Without brake

- R88M-K20030□ (-S2)/-K40030□ (-S2) **INC**
- R88M-K20030□ (-S2)/-K40030□ (-S2) **ABS**

Model	Dimensions (mm)		
	LL	LM	LN
R88M-K20030□	79.5	56.5	11
R88M-K40030□	99	76	14

CAD data

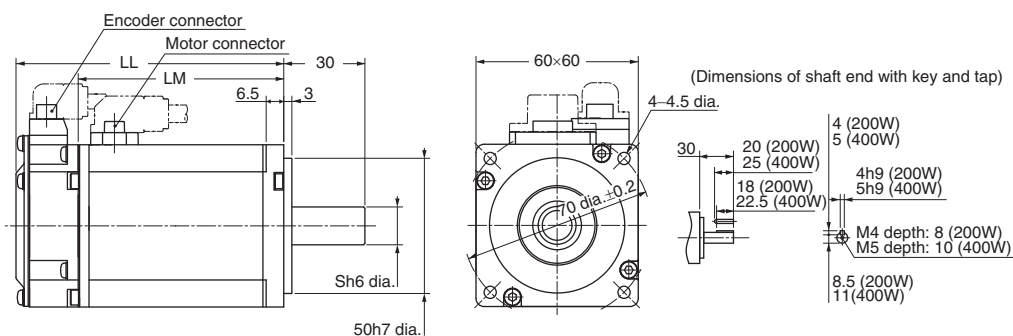

Note: The standard models have a straight shaft. A model with a key and tap is indicated by adding "S2" to the end of the model number. Models with an oil seal are indicated with O at the end of the model number. The motor dimensions do not change.

• With brake

- R88M-K20030□-B (S2)/-K40030□-B (S2) **INC**
- R88M-K20030□-B (S2)/-K40030□-B (S2) **ABS**

Model	Dimensions (mm)		
	LL	LM	S
R88M-K20030□-B□	116	93	11
R88M-K40030□-B□	135.5	112.5	14

CAD data

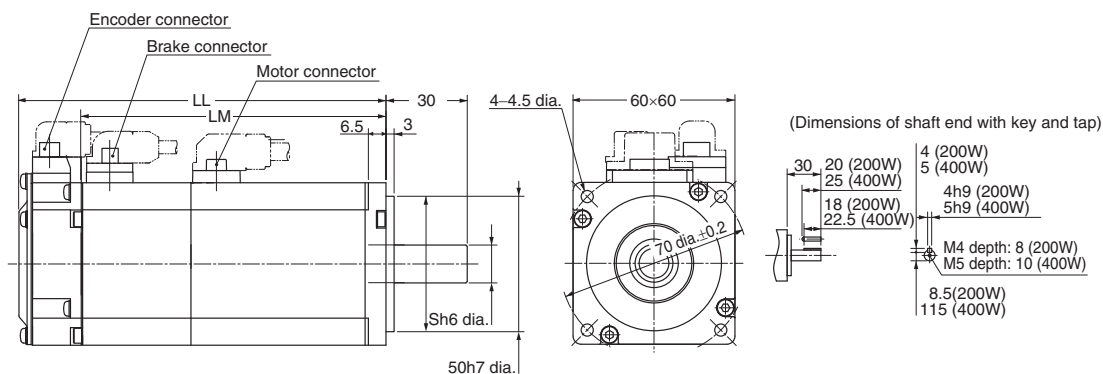

750W

• Without brake

- R88M-K75030H (-S2) **INC**
- R88M-K75030T (-S2) **ABS**

CAD data

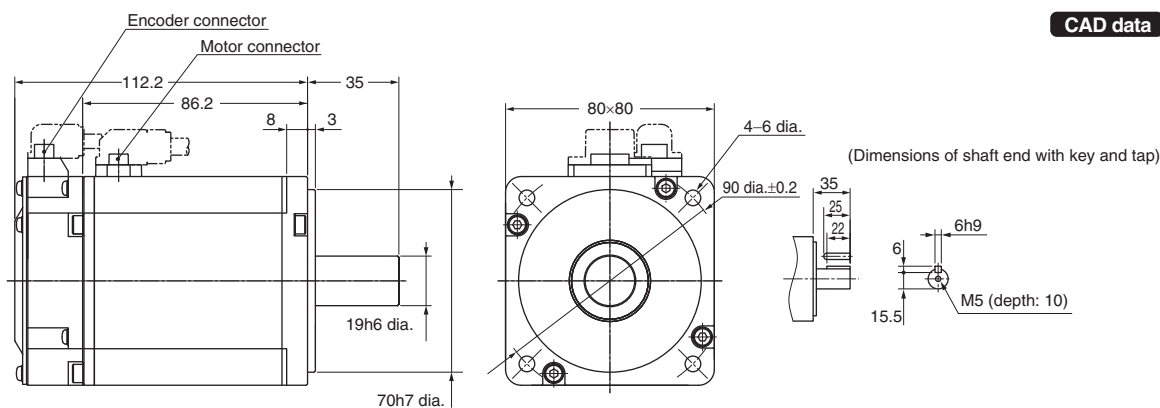

• With brake

- R88M-K75030H-B (S2) **INC**
- R88M-K75030T-B (S2) **ABS**

CAD data

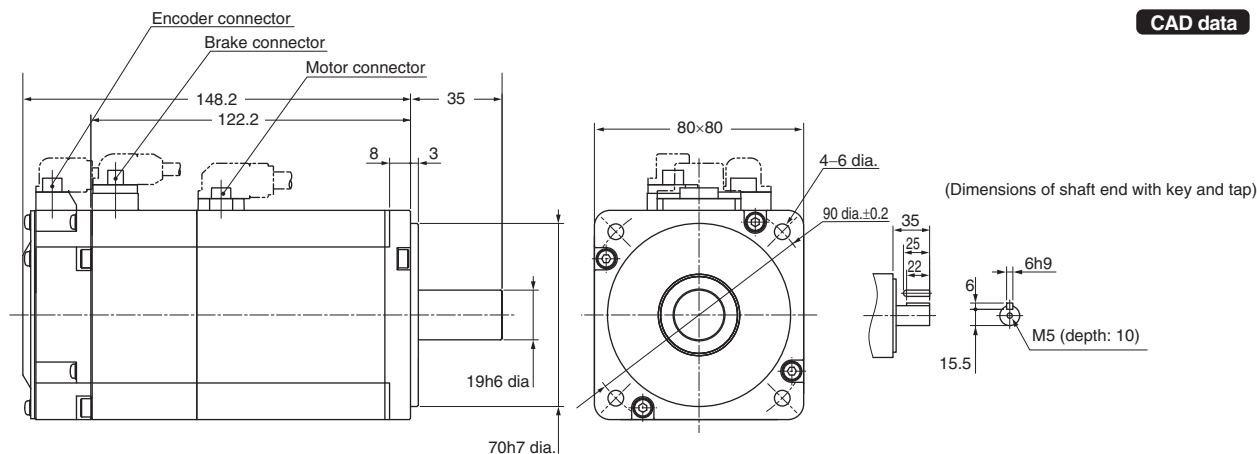

Note: The standard models have a straight shaft. A model with a key and tap is indicated by adding "S2" to the end of the model number. Models with an oil seal are indicated with O at the end of the model number. The motor dimensions do not change.

AC Servomotor/Drive G5-series

1kW/1.5kW/2kW

• Without brake

- R88M-K1K030H (-S2)/-K1K530H (-S2)/-K2K030H (-S2) **INC**
- R88M-K1K030T (-S2)/-K1K530T (-S2)/-K2K030T (-S2) **ABS**

• With brake

- R88M-K1K030H-B (S2)/-K1K530H-B (S2)/-K2K030H-B (S2) **INC**
- R88M-K1K030T-B (S2)/-K1K530T-B (S2)/-K2K030T-B (S2) **ABS**

Model	Dimensions (mm)			
	LL	LM	KB1	KB2
R88M-K1K030□	141	97	66	119
R88M-K1K530□	159.5	115.5	84.5	137.5
R88M-K2K030□	178.5	134.5	103.5	156.5
R88M-K1K030□-B□	168	124	66	146
R88M-K1K530□-B□	186.5	142.5	84.5	164.5
R88M-K2K030□-B□	205.5	161.5	103.5	183.5

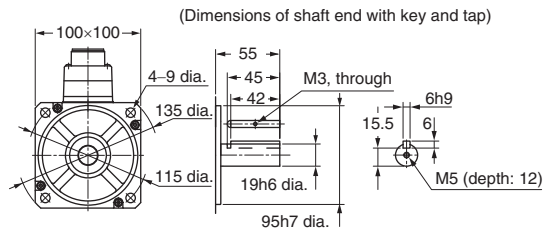
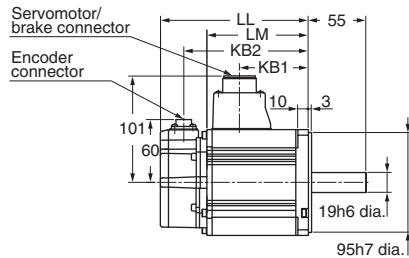

CAD data

3kW

• Without brake

- R88M-K3K030H (-S2) **INC**
- R88M-K3K030T (-S2) **ABS**

• With brake

- R88M-K3K030H-B (S2) **INC**
- R88M-K3K030T-B (S2) **ABS**

Model	Dimensions (mm)		
	LL	LM	KB2
R88M-K3K030□	190	146	168
R88M-K3K030□-B□	215	171	193

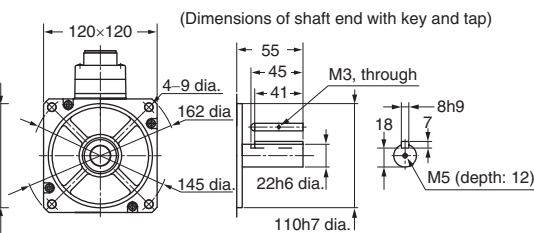
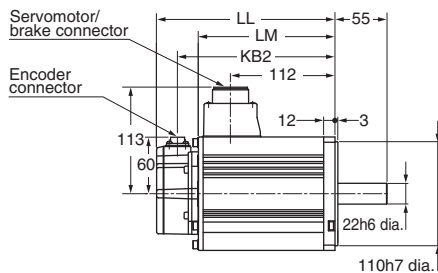

CAD data

4kW/5kW

• Without brake

- R88M-K4K030H (-S2)/-K5K030H (-S2) **INC**
- R88M-K4K030T (-S2)/-K5K030T (-S2) **ABS**

• With brake

- R88M-K4K030H-B (S2)/-K5K030H-B (S2) **INC**
- R88M-K4K030T-B (S2)/-K5K030T-B (S2) **ABS**

Model	Dimensions (mm)			
	LL	LM	KB1	KB2
R88M-K4K030□	208	164	127	186
R88M-K5K030□	243	199	162	221
R88M-K4K030□-B□	236	192	127	214
R88M-K5K030□-B□	271	227	162	249

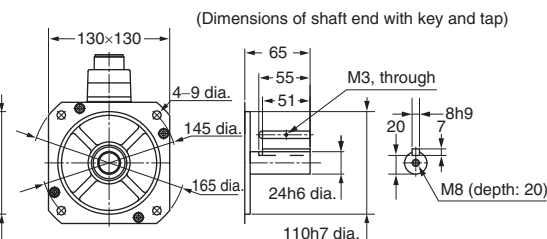
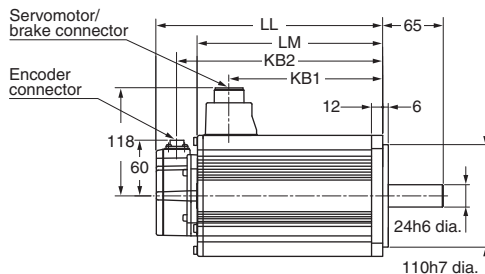

CAD data

Note: The standard models have a straight shaft. A model with a key and tap is indicated by adding "S2" to the end of the model number. Models with an oil seal are indicated with O at the end of the model number. The motor dimensions do not change.

3,000 r/min Servomotors (400 VAC)

750W/1kW/1.5kW/2kW

• Without brake

- R88M-K75030F (-S2)/-K1K030F (-S2)/-K1K530F (-S2)/-K2K030F (-S2) **INC**
- R88M-K75030C (-S2)/-K1K030C (-S2)/-K1K530C (-S2)/-K2K030C (-S2) **ABS**

• With brake

- R88M-K75030F-B (S2)/-K1K030F-B (S2)/-K1K530F-B (S2)/-K2K030F-B (S2) **INC**
- R88M-K75030C-B (S2)/-K1K030C-B (S2)/-K1K530C-B (S2)/-K2K030C-B (S2) **ABS**

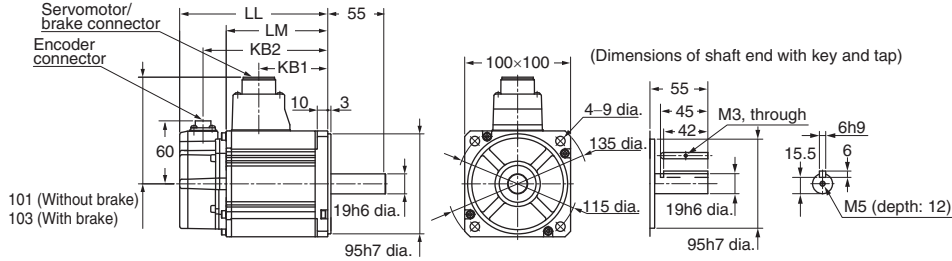

CAD data

Model	Dimensions (mm)			
	LL	LM	KB1	KB2
R88M-K75030□	131.5	87.5	56.5	109.5
R88M-K1K030□	141	97	66	119
R88M-K1K530□	159.5	115.5	84.5	137.5
R88M-K2K030□	178.5	134.5	103.5	156.5
R88M-K75030□-B□	158.5	114.5	53.5	136.5
R88M-K1K030□-B□	168	124	63	146
R88M-K1K530□-B□	186.5	142.5	81.5	164.5
R88M-K2K030□-B□	205.5	161.5	100.5	183.5

3kW

• Without brake

- R88M-K3K030F (-S2) **INC**
- R88M-K3K030C (-S2) **ABS**

• With brake

- R88M-K3K030F-B (S2) **INC**
- R88M-K3K030C-B (S2) **ABS**

Model	Dimensions (mm)		
	LL	LM	KB2
R88M-K3K030□	190	146	168
R88M-K3K030□-B□	215	171	193

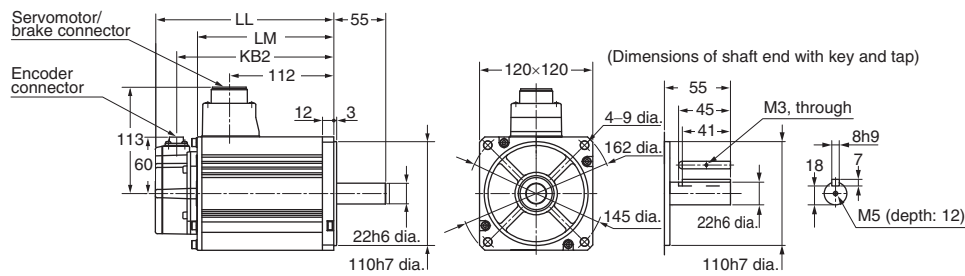

CAD data

Note: The standard models have a straight shaft. A model with a key and tap is indicated by adding "S2" to the end of the model number. Models with an oil seal are indicated with O at the end of the model number. The motor dimensions do not change.

AC Servomotor/Drive G5-series

4kW/5kW

• Without brake

- R88M-K4K030F (-S2)/-K5K030F (-S2) **INC**
- R88M-K4K030C (-S2)/-K5K030C (-S2) **ABS**

• With brake

- R88M-K4K030F-B (S2)/-K5K030F-B (S2) **INC**
- R88M-K4K030C-B (S2)/-K5K030C-B (S2) **ABS**

Model	Dimensions (mm)			
	LL	LM	KB1	KB2
R88M-K4K030□	208	164	127	186
R88M-K5K030□	243	199	162	221
R88M-K4K030□-B□	236	192	127	214
R88M-K5K030□-B□	271	227	162	249

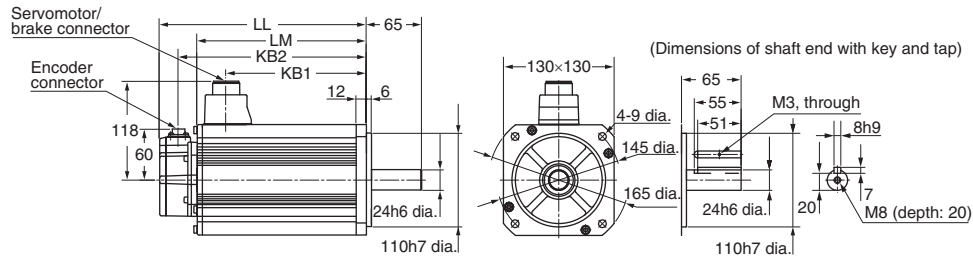

Note: The standard models have a straight shaft. A model with a key and tap is indicated by adding “S2” to the end of the model number. Models with an oil seal are indicated with O at the end of the model number. The motor dimensions do not change.

1,500r/min, 2,000 r/min Servomotors (200 VAC)

1kW/1.5kW/2kW/3kW

• Without brake

- R88M-K1K020H (-S2)/-K1K520H (-S2)/-K2K020H (-S2)/-K3K020H (-S2) **INC**
- R88M-K1K020T (-S2)/-K1K520T (-S2)/-K2K020T (-S2)/-K3K020T (-S2) **ABS**

• With brake

- R88M-K1K020H-B (S2)/-K1K520H-B (S2)/-K2K020H-B (S2)/-K3K020H-B (S2) **INC**
- R88M-K1K020T-B (S2)/-K1K520T-B (S2)/-K2K020T-B (S2)/-K3K020T-B (S2) **ABS**

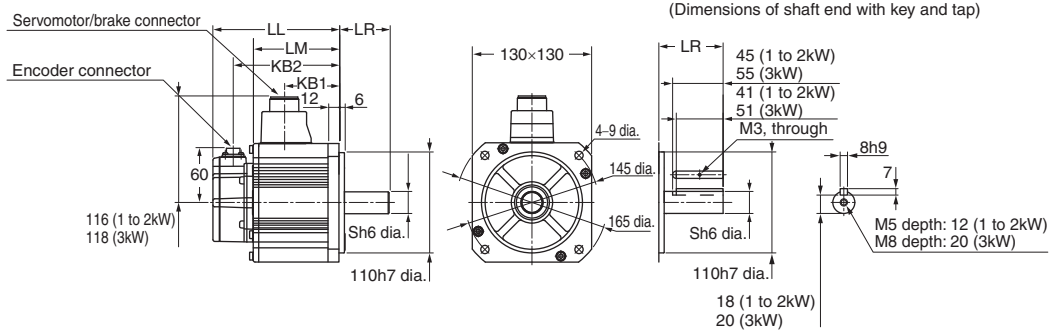

Model	Dimensions (mm)					
	LL	LR	LM	S	KB1	KB2
R88M-K1K020□	138	55	94	22	60	116
R88M-K1K520□	155.5	55	111.5	22	77.5	133.5
R88M-K2K020□	173	55	129	22	95	151
R88M-K3K020□	208	65	164	24	127	186
R88M-K1K020□-B□	166	55	122	22	60	144
R88M-K1K520□-B□	183.5	55	139.5	22	77.5	161.5
R88M-K2K020□-B□	201	55	157	22	95	179
R88M-K3K020□-B□	236	65	192	24	127	214

4kW/5kW

• Without brake

- R88M-K4K020H (-S2)/-K5K020H (-S2) **INC**
- R88M-K4K020T (-S2)/-K5K020T (-S2) **ABS**

• With brake

- R88M-K4K020H-B (S2)/-K5K020H-B (S2) **INC**
- R88M-K4K020T-B (S2)/-K5K020T-B (S2) **ABS**

Model	Dimensions (mm)			
	LL	LM	KB1	KB2
R88M-K4K020□	177	133	96	155
R88M-K5K020□	196	152	115	174
R88M-K4K020□-B□	206	162	96	184
R88M-K5K020□-B□	225	181	115	203

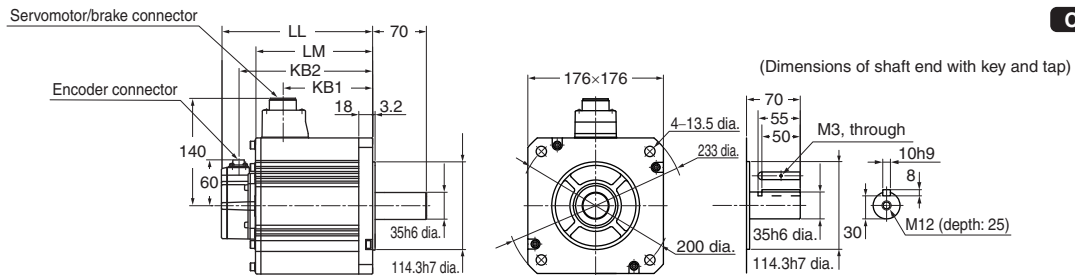

Note: The standard models have a straight shaft. A model with a key and tap is indicated by adding "S2" to the end of the model number. Models with an oil seal are indicated with O at the end of the model number. The motor dimensions do not change.

G5-Series
System Configuration

EtherCAT Communications
AC Servo Drive

EtherCAT Communications
Linear Motor Type
AC Servo Drive

General-purpose Inputs
AC Servo Drive

ML-II Type
AC Servo Drive

AC Servomotors

Linear Motor

AC Servomotor/Drive G5-series

7.5kW

• Without brake

- R88M-K7K515T (-S2) **ABS**

• With brake

- R88M-K7K515T-B (S2) **ABS**

Model	Dimensions (mm)								
	LL	LR	LM	S	KB1	KB2	L1	L2	L3
R88M-K7K515T□	312	113	268	42	219	290	117.5	117.5	149
R88M-K7K515T-B□	337	113	293	42	253	315	117.5	152.5	183

CAD data

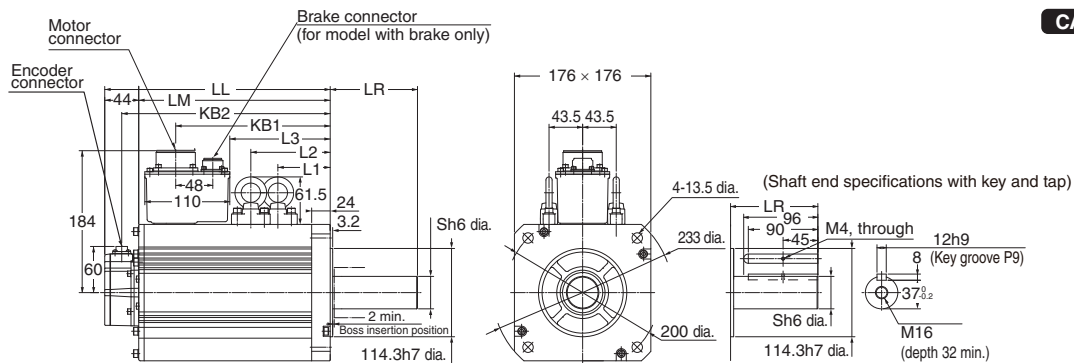

11kW/15kW

• Without brake

- R88M-K11K015T (-S2)/-K15K015T (-S2) **ABS**

• With brake

- R88M-K11K015T-B (S2)/R88M-K15K015T-B (S2) **ABS**

CAD data

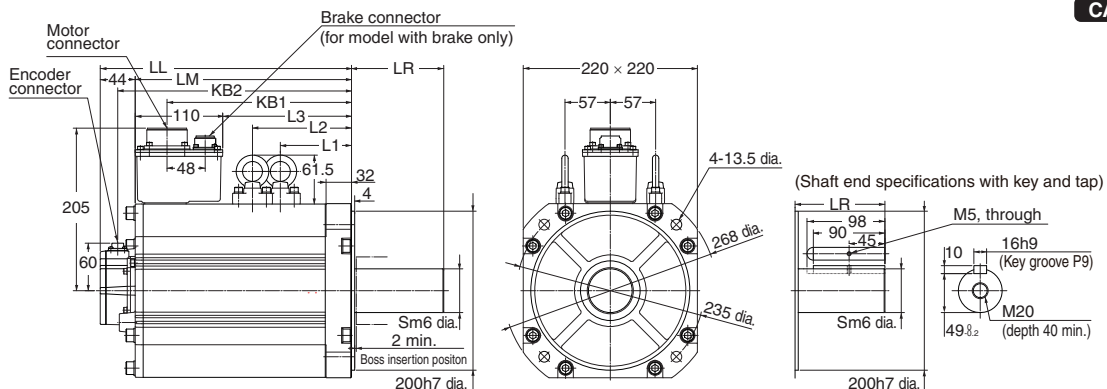

Model	Dimensions (mm)								
	LL	LR	LM	S	KB1	KB2	L1	L2	L3
R88M-K11K015T□	316	116	272	55	232	294	124.5	124.5	162
R88M-K15K015T□	384	116	340	55	300	362	158.5	158.5	230
R88M-K11K015T-B□	364	116	320	55	266	342	124.5	159.5	196
R88M-K15K015T-B□	432	116	388	55	334	410	158.5	193.5	264

Note: The standard models have a straight shaft. A model with a key and tap is indicated by adding "S2" to the end of the model number. Models with an oil seal are indicated with O at the end of the model number. The motor dimensions do not change.

1,500 r/min, 2,000 r/min Servomotors (400 VAC)

400W/600W

• Without brake

- R88M-K40020F (-S2)/-K60020F (-S2) **INC**
- R88M-K40020C (-S2)/-K60020C (-S2) **ABS**

• With brake

- R88M-K40020F-B (S2)/-K60020F-B (S2) **INC**
- R88M-K40020C-B (S2)/-K60020C-B (S2) **ABS**

Model	Dimensions (mm)			
	LL	LM	KB1	KB2
R88M-K40020□	131.5	87.5	56.5	109.5
R88M-K60020□	141	97	66	119
R88M-K40020□-B□	158.5	114.5	53.5	136.5
R88M-K60020□-B□	168	124	63	146

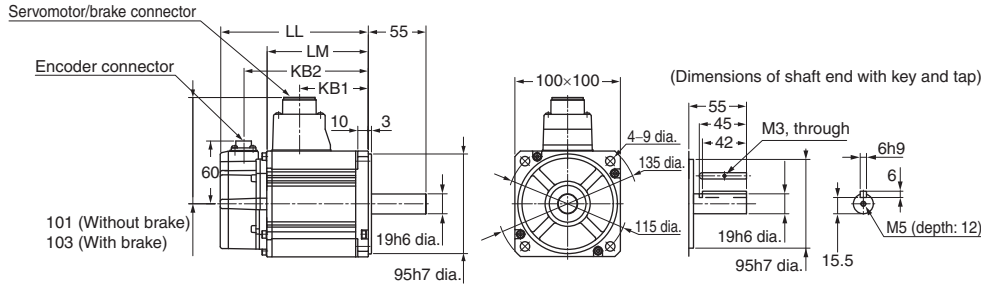

CAD data

1kW/1.5kW/2kW/3kW

• Without brake

- R88M-K1K020F (-S2)/-K1K520F (-S2)/-K2K020F (-S2)/-K3K020F (-S2) **INC**
- R88M-K1K020C (-S2)/-K1K520C (-S2)/-K2K020C (-S2)/-K3K020C (-S2) **ABS**

• With brake

- R88M-K1K020F-B (S2)/-K1K520F-B (S2)/-K2K020F-B (S2)/-K3K020F-B (S2) **INC**
- R88M-K1K020C-B (S2)/-K1K520C-B (S2)/-K2K020C-B (S2)/-K3K020C-B (S2) **ABS**

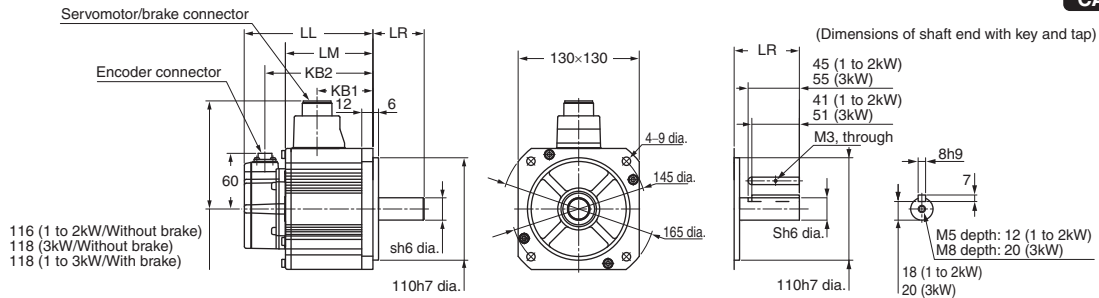

CAD data

Model	Dimensions (mm)					
	LL	LR	LM	S	KB1	KB2
R88M-K1K020□	138	55	94	22	60	116
R88M-K1K520□	155.5	55	111.5	22	77.5	133.5
R88M-K2K020□	173	55	129	22	95	151
R88M-K3K020□	208	65	164	24	127	186
R88M-K1K020□-B□	166	55	122	22	57	144
R88M-K1K520□-B□	183.5	55	139.5	22	74.5	161.5
R88M-K2K020□-B□	201	55	157	22	92	179
R88M-K3K020□-B□	236	65	192	24	127	214

Note: The standard models have a straight shaft. A model with a key and tap is indicated by adding "S2" to the end of the model number. Models with an oil seal are indicated with O at the end of the model number. The motor dimensions do not change.

G5-Series
System Configuration

EtherCAT Communications
AC Servo Drive

EtherCAT Communications
Linear Motor Type
AC Servo Drive

General-purpose Inputs
AC Servo Drive

ML-II Type
AC Servo Drive

AC Servomotors

Linear Motor

AC Servomotor/Drive G5-series

4kW/5kW

• Without brake

- R88M-K4K020F (-S2)/-K5K020F (-S2) **INC**
- R88M-K4K020C (-S2)/-K5K020C (-S2) **ABS**

• With brake

- R88M-K4K020F-B (S2)/-K5K020F-B (S2) **INC**
- R88M-K4K020C-B (S2)/-K5K020C-B (S2) **ABS**

Model	Dimensions (mm)			
	LL	LM	KB1	KB2
R88M-K4K020□	177	133	96	155
R88M-K5K020□	196	152	115	174
R88M-K4K020□-B□	206	162	96	184
R88M-K5K020□-B□	225	181	115	203

CAD data

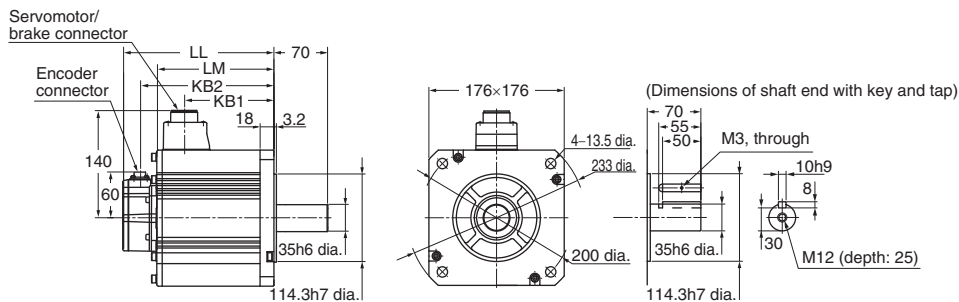

7.5kW

• Without brake

- R88M-K7K515C (-S2) **ABS**

• With brake

- R88M-K7K515C-B (S2) **ABS**

Model	Dimensions (mm)								
	LL	LR	LM	S	KB1	KB2	L1	L2	L3
R88M-K7K515C□	312	133	268	42	219	290	117.5	117.5	149
R88M-K7K515C-B□	337	113	293	42	253	315	117.5	152.5	183

CAD data

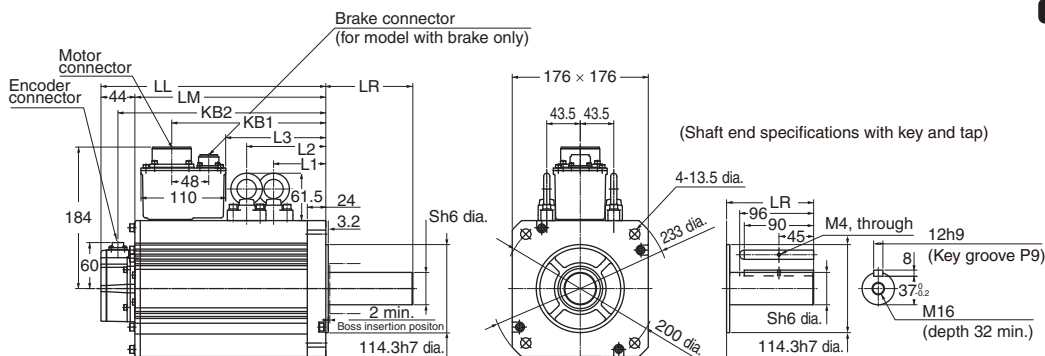

Note: The standard models have a straight shaft. A model with a key and tap is indicated by adding "S2" to the end of the model number. Models with an oil seal are indicated with O at the end of the model number. The motor dimensions do not change.

11kW/15kW

• Without brake

- R88M-K11K015C (-S2)/K15K015C (-S2) **ABS**

• With brake

- R88M-K11K015C-B (S2)/R88M-K15K015C-B (S2) **ABS**

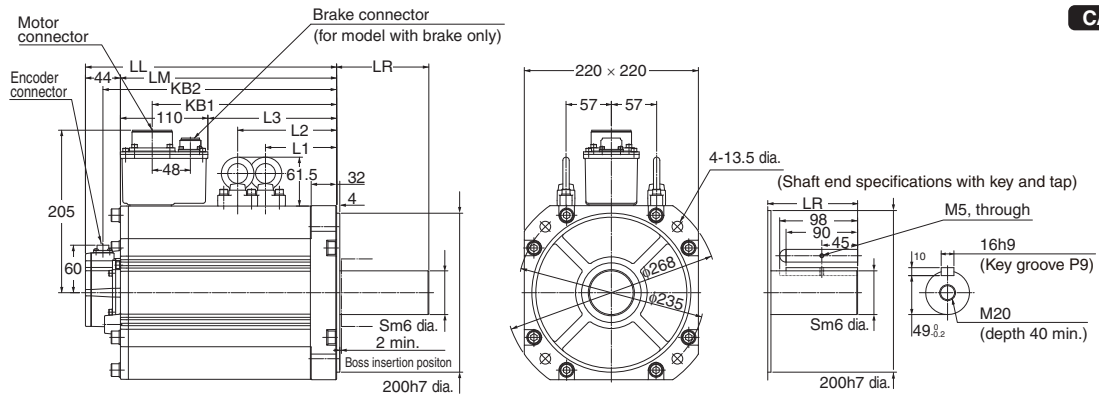

CAD data

Model	Dimensions (mm)								
	LL	LR	LM	S	KB1	KB2	L1	L2	L3
R88M-K11K015C□	316	116	272	55	232	294	124.5	124.5	162
R88M-K15K015C□	384	116	340	55	300	362	158.5	158.5	230
R88M-K11K015C-B□	364	116	320	55	266	342	124.5	159.5	196
R88M-K15K015C-B□	432	116	388	55	334	410	158.5	193.5	264

Note: The standard models have a straight shaft. A model with a key and tap is indicated by adding "S2" to the end of the model number. Models with an oil seal are indicated with O at the end of the model number. The motor dimensions do not change.

AC Servomotor/Drive G5-series

1,000 r/min Servomotors (200 VAC)

900W

• Without brake

- R88M-K90010H (-S2) **INC**
- R88M-K90010T (-S2) **ABS**

• With brake

- R88M-K90010H-B (S2) **INC**
- R88M-K90010T-B (S2) **ABS**

Model	Dimensions (mm)		
	LL	LM	KB2
R88M-K90010□	155.5	111.5	133.5
R88M-K90010□-B□	183.5	139.5	161.5

CAD data

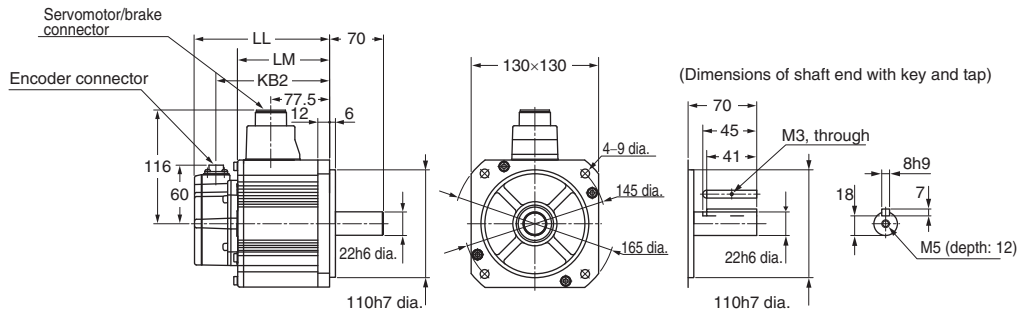

2kW/3kW

• Without brake

- R88M-K2K010H (-S2)/-K3K010H (-S2) **INC**
- R88M-K2K010T (-S2)/-K3K010T (-S2) **ABS**

• With brake

- R88M-K2K010H-B (S2)/-K3K010H-B (S2) **INC**
- R88M-K2K010T-B (S2)/-K3K010T-B (S2) **ABS**

Model	Dimensions (mm)			
	LL	LM	KB1	KB2
R88M-K2K010□	163.5	119.5	82.5	141.5
R88M-K3K010□	209.5	165.5	128.5	187.5
R88M-K2K010□-B□	192.5	148.5	82.5	170.5
R88M-K3K010□-B□	238.5	194.5	128.5	216.5

CAD data

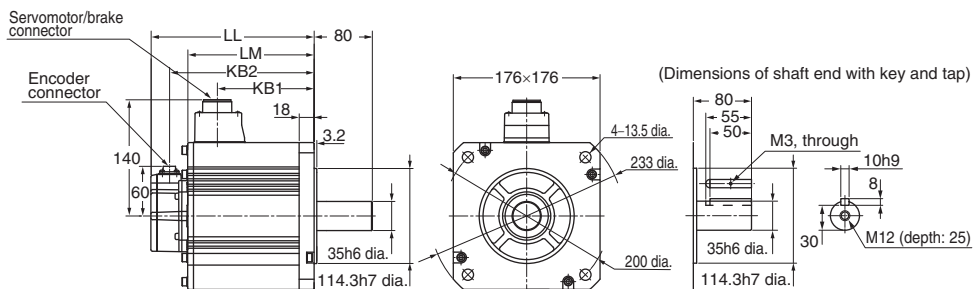

4.5kW

• Without brake

- R88M-K4K510T (-S2) **ABS**

• With brake

- R88M-K4K510T-B (S2) **ABS**

Model	Dimensions (mm)							
	LL	LR	LM	S	KB1	KB2	L1	L2
R88M-K4K510T□	266	113	222	42	185	244	98	98
R88M-K4K510T-B□	291	113	247	42	185	269	98	133

CAD data

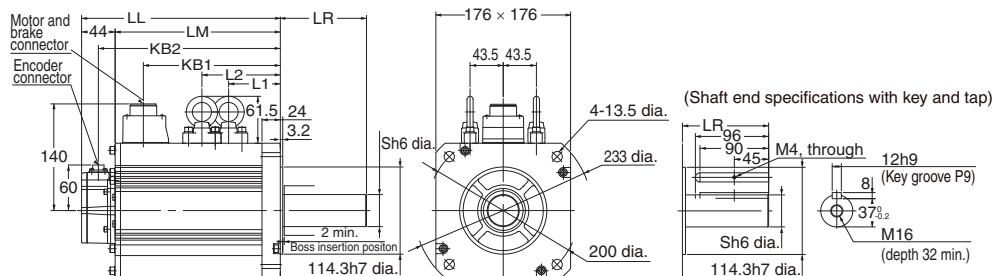

Note: The standard models have a straight shaft. A model with a key and tap is indicated by adding "S2" to the end of the model number. Models with an oil seal are indicated with O at the end of the model number. The motor dimensions do not change.

6kW

• Without brake

- R88M-K6K010T (-S2) **ABS**

• With brake

- R88M-K6K010T-B (S2) **ABS**

Model	Dimensions (mm)								
	LL	LR	LM	S	KB1	KB2	L1	L2	L3
R88M-K6K010T□	312	113	268	42	219	290	117.5	117.5	149
R88M-K6K010T-B□	337	113	293	42	253	315	117.5	152.5	183

CAD data

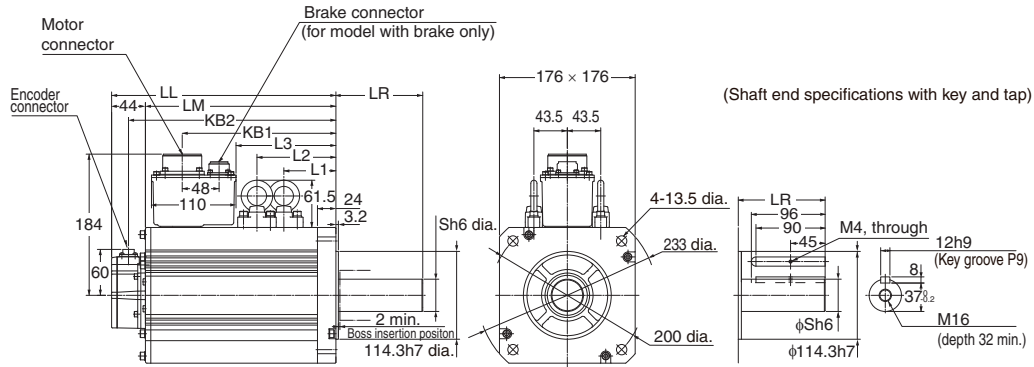

Note: The standard models have a straight shaft. A model with a key and tap is indicated by adding "S2" to the end of the model number. Models with an oil seal are indicated with O at the end of the model number. The motor dimensions do not change.

AC Servomotor/Drive G5-series

1,000 r/min Servomotors (400 VAC)

900W

• Without brake

- R88M-K90010F (-S2) **INC**
- R88M-K90010C (-S2) **ABS**

• With brake

- R88M-K90010F-B (S2) **INC**
- R88M-K90010C-B (S2) **ABS**

Model	Dimensions (mm)			
	LL	LM	KB1	KB2
R88M-K90010□	155.5	111.5	77.5	133.5
R88M-K90010□-B□	183.5	139.5	74.5	161.5

CAD data

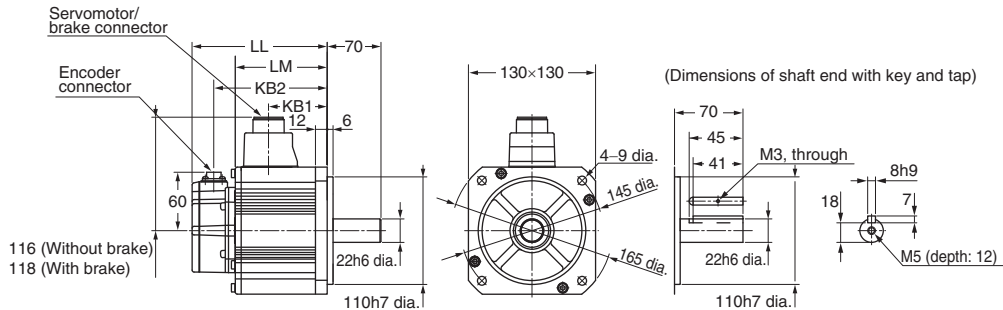

2kW/3kW

• Without brake

- R88M-K2K010F (-S2)/-K3K010F (-S2) **INC**
- R88M-K2K010C (-S2)/-K3K010C (-S2) **ABS**

• With brake

- R88M-K2K010F-B (S2)/-K3K010F-B (S2) **INC**
- R88M-K2K010C-B (S2)/-K3K010C-B (S2) **ABS**

Model	Dimensions (mm)			
	LL	LM	KB1	KB2
R88M-K2K010□	163.5	119.5	82.5	141.5
R88M-K3K010□	209.5	165.5	128.5	187.5
R88M-K2K010□-B□	192.5	148.5	82.5	170.5
R88M-K3K010□-B□	238.5	194.5	128.5	216.5

CAD data

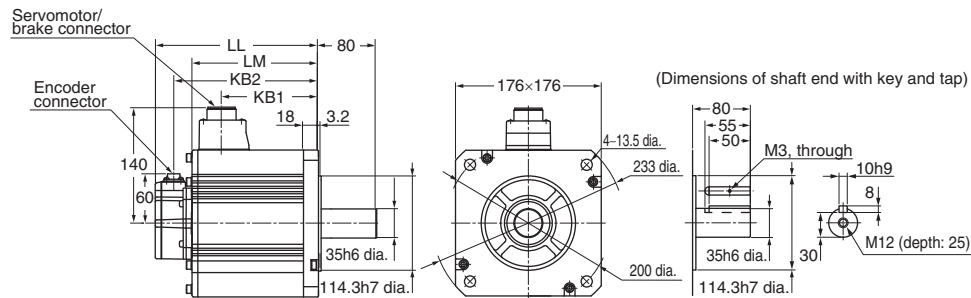

4.5kW

• Without brake

- R88M-K4K510C (-S2) **ABS**

• With brake

- R88M-K4K510C-B (S2) **ABS**

Model	Dimensions (mm)							
	LL	LR	LM	S	KB1	KB2	L1	L2
R88M-K4K510T□	266	113	222	42	185	244	98	98
R88M-K4K510T-B□	291	113	247	42	185	269	98	133

CAD data

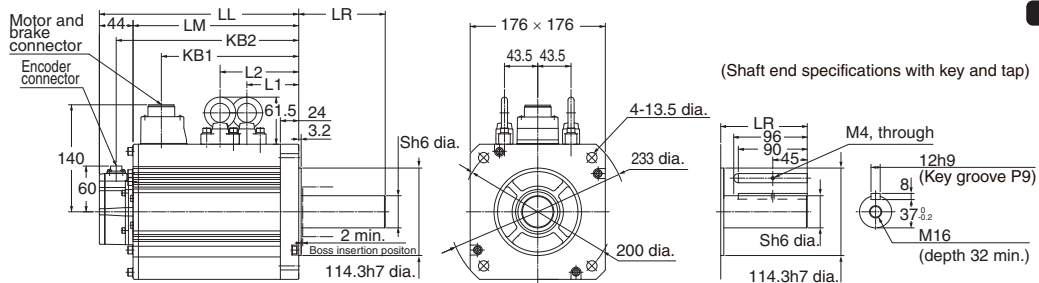

Note: The standard models have a straight shaft. A model with a key and tap is indicated by adding "S2" to the end of the model number. Models with an oil seal are indicated with O at the end of the model number. The motor dimensions do not change.

6kW

• Without brake

- R88M-K6K010C (-S2) **ABS**

• With brake

- R88M-K6K010C-B (S2) **ABS**

Model	Dimensions (mm)								
	LL	LR	LM	S	KB1	KB2	L1	L2	L3
R88M-K6K010C□	312	113	268	42	219	290	117.5	117.5	149
R88M-K6K010C-B□	337	113	293	42	253	315	117.5	152.5	183

CAD data

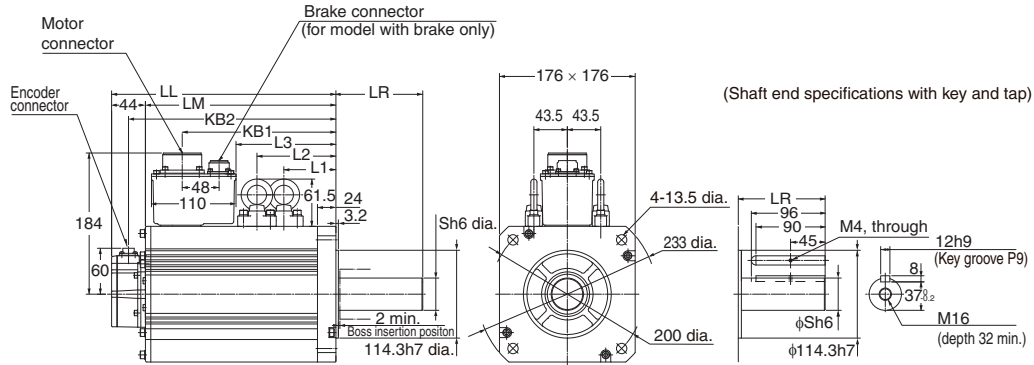

Note: The standard models have a straight shaft. A model with a key and tap is indicated by adding "S2" to the end of the model number. Models with an oil seal are indicated with O at the end of the model number. The motor dimensions do not change.

G5-series Linear Motor

R88L-EC-□

Contents

- Ordering Information
- Specifications
 - General Specifications
 - Iron-core Linear Motors
 - Ironless Linear Motors
 - Characteristics
 - Iron-core Linear Motors
 - Ironless Linear Motors
- Dimensions

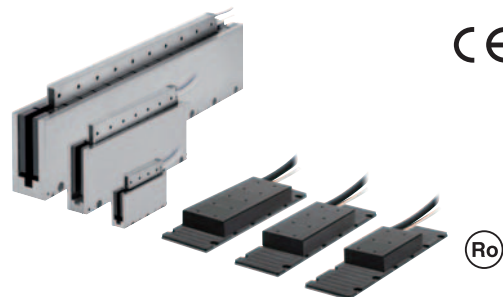

Ordering Information

Refer to the Ordering Information.

Specifications

General Specifications

● Iron-core Linear Motors

Item	Description
Operating ambient temperature humidity	0 to 40°C, 20% to 80% (with no condensation)
Storage ambient temperature and humidity	-20 to +65°C, 85% max. (with no condensation)
Operating and storage atmosphere	No corrosive gases
Vibration resistance*	Acceleration of 49 m/s ² max. in X, Y, and Z directions
Impact resistance	Acceleration of 98 m/s ² max. 3 times each in X, Y, and Z directions
Insulation resistance	Between power terminal and FG terminal: 10 MΩ min. (at 500 VDC)
Dielectric strength	Between power terminal and FG terminal: 2,750 VDC for 1 s Between power terminal and sensor: 2,750 VDC for 1 s
Protective structure	IP00
Maximum coil temperature (Motor Coil Unit)	130°C
Maximum magnet temperature (Magnet Track)	70°C
Insulation class	Class B
Cooling method	Self-cooling
International standard	EN60034-1
EC directive	
Low voltage directive	

● Ironless Linear Motors

Item	Description
Operating ambient temperature humidity	0 to 40°C, 20% to 80% (with no condensation)
Storage ambient temperature and humidity	-20 to +65°C, 85% max. (with no condensation)
Operating and storage atmosphere	No corrosive gases
Vibration resistance*	Acceleration of 49 m/s ² max. in X, Y, and Z directions
Impact resistance	Acceleration of 98 m/s ² max. 3 times each in X, Y, and Z directions
Insulation resistance	Between power terminal and FG terminal: 10 MΩ min. (at 500 VDC)
Dielectric strength	Between power terminal and FG terminal: 2,250 VDC for 1 s Between power terminal and sensor: 2,250 VDC for 1 s
Protective structure	IP00
Maximum coil temperature (Motor Coil Unit)	110°C
Maximum magnet temperature (Magnet Track)	70°C
Insulation class	Class B
Cooling method	Self-cooling
International standard	EN60034-1
EC directive	
Low voltage directive	

* The amplitude may be increased by machine resonance. As a guideline, do not exceed 80% of the specified value.

Characteristics/Speed - Force Characteristics

Characteristics

● Iron-core Linear Motors

Item	Unit	R88L-EC-						
		FW-0303-ANPC	FW-0306-ANPC	FW-0606-ANPC	FW-0609-ANPC	FW-0612-ANPC	FW-1112-ANPC	FW-1115-ANPC
Maximum speed (100VAC)	m/s	2.5	2.5	2	-	-	-	-
Maximum speed (200VAC)	m/s	5	5	4	4	4	2	2
Maximum speed (400VAC)	m/s	10	10	8	8	8	4	4
Continuous force*1	N	48	96	160	240	320	608	760
Momentary maximum force*2	N	105	210	400	600	800	1,600	2,000
Continuous current*2	Arms	1.24	2.4	3.4	5.2	6.9	6.5	8.2
Momentary maximum current*1	Arms	3.1	6.1	10	15	20	20	25
Motor force constant	N/Arms	39.7	39.7	46.5	46.5	46.5	93.0	93.0
Back electromotive force	V·s/m	13.2	13.2	15.5	15.5	15.5	31	31
Motor constant	N/√W	9.75	13.78	19.49	23.87	27.57	41.47	46.37
Phase resistance	Ω	5.34	2.68	1.83	1.23	0.92	1.6	1.29
Phase inductance	mH	34.7	17.4	13.7	9.2	6.9	12.8	10.3
Electrical time constant	ms	6.5	6.5	7.5	7.5	7.5	8	8
Maximum continuous power consumption	W	32	63	88	131	175	279	349
Thermal resistance	K/W	2.20	1.10	0.78	0.52	0.39	0.23	0.18
Thermal time constant	s	110	110	124	124	124	126	126
Magnetic attractive force	N	300	500	1,020	1,420	1,820	3,640	4,440
Magnetic pole pitch	mm	24	24	24	24	24	24	24
Mass (except cables)	kg	0.48	0.78	1.31	1.84	2.37	4.45	5.45
Cooling plate dimensions	mm	238×220×10	238×220×10	250×287×12	250×287×12	250×287×12	371×330×14	371×330×14
Application Servo Drives (R88D-□-ECT-L)		KN01L/KN02H/KN06F	KN02L/KN04H/KN10F	KN04L/KN08H/KN15F	KN10H/KN20F	KN15H/KN30F	KN15H/KN30F	KN15H/KN30F
Magnet Trac (R88L-EC-)		FM-03096-A/FM-03144-A/ FM-03384-A		FM-06192-A/FM-06288-A			FM-11192-A/FM-11288-A	
Magnet Trac Unit Length	mm	96/144/384		192/288			192/288	

*1. This shows a value measured when the Motor Coil Unit is at 100°C and the Magnet Trac is at 25°C. The coil unit is mounted in the center of an aluminum moving table (heat sink) which has its size larger than indicated in table as cooling condition.

*2. The Motor Coil Unit is subjected to a temperature rise of 6 K/s.

AC Servomotor/Drive G5-series

Speed - Force Characteristics

The following graphs show the performance when the coil temperature of the Motor Coil Unit is 100°C.

The maximum operation speed is limited by considering the guide mechanism, encoder, and other aspects. If it is 5 m/s or higher, please consult with your OMRON representative.

R88L-EC-FW-0303

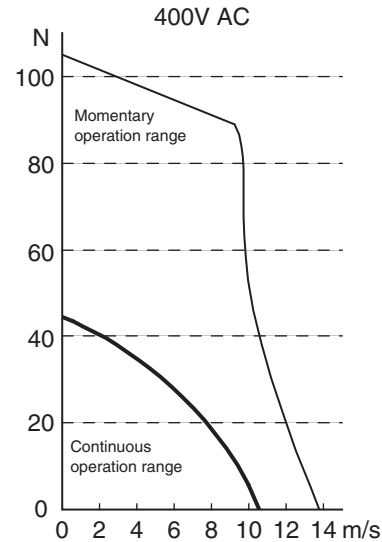
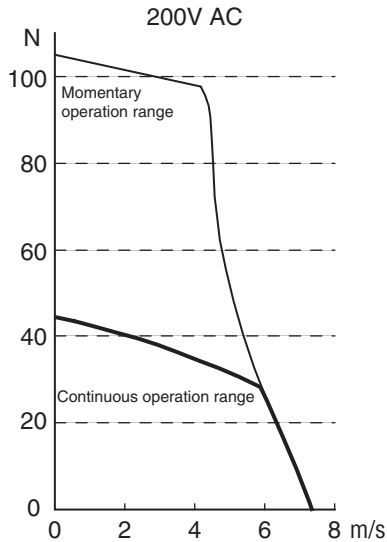
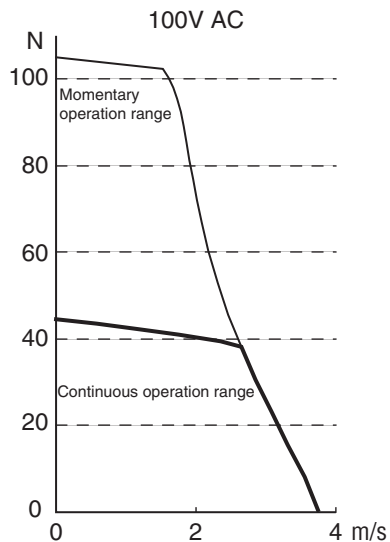

R88L-EC-FW-0306

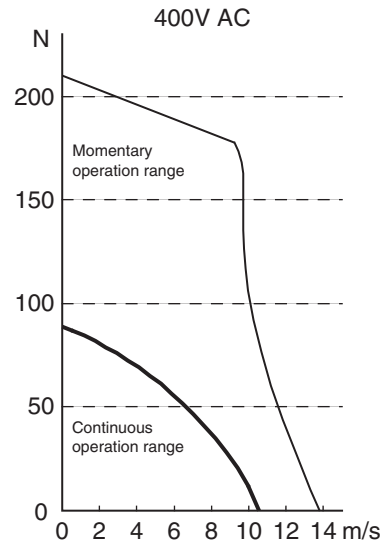
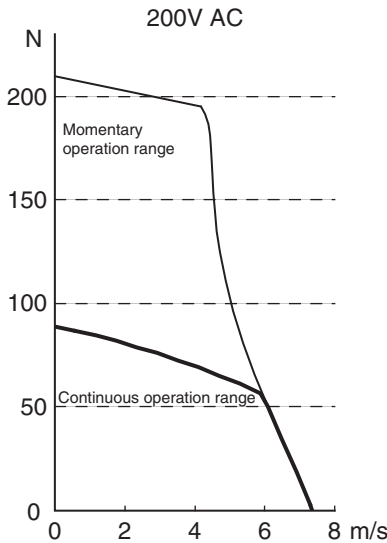
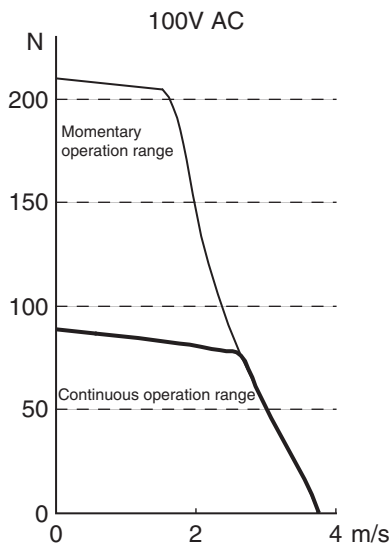

R88L-EC-FW-0606

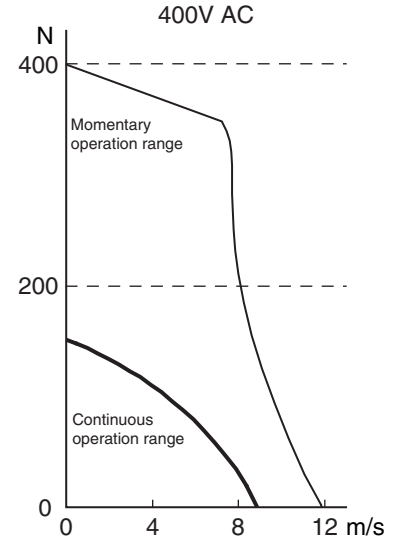
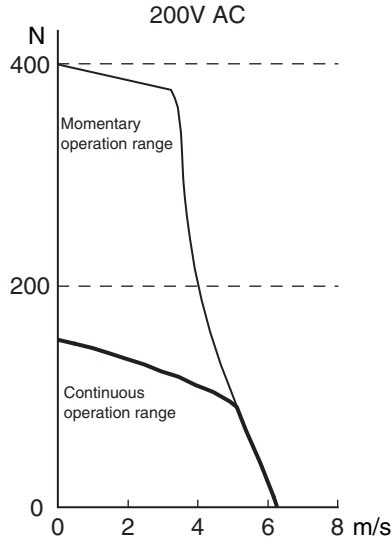
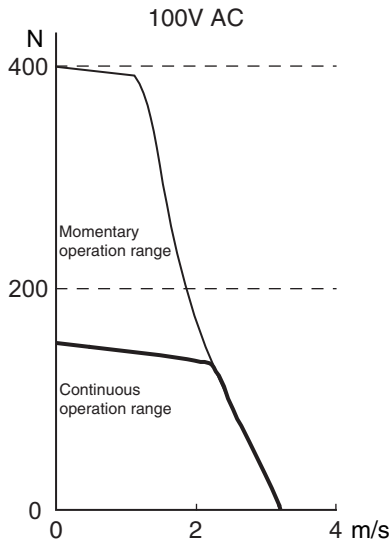

R88L-EC-FW-0609

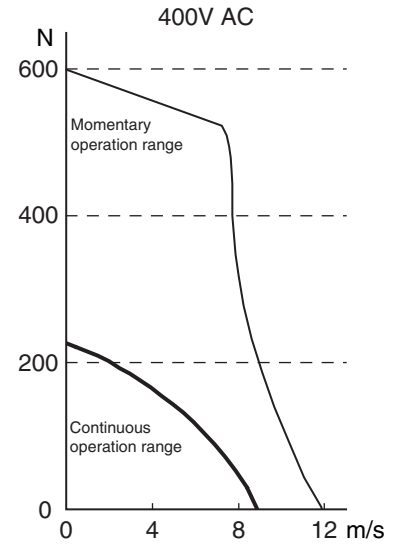
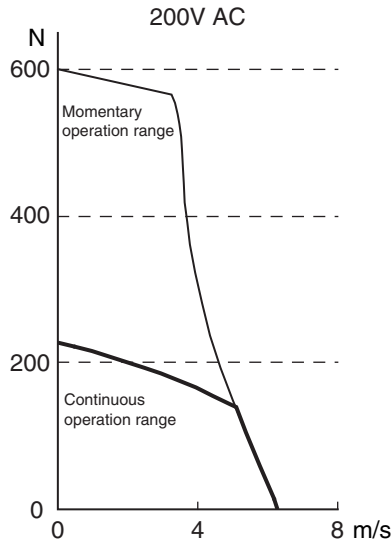
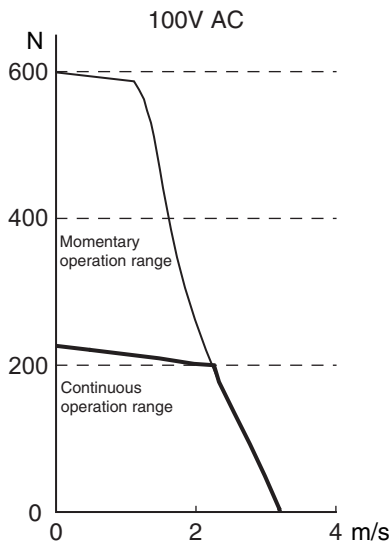

R88L-EC-FW-0612

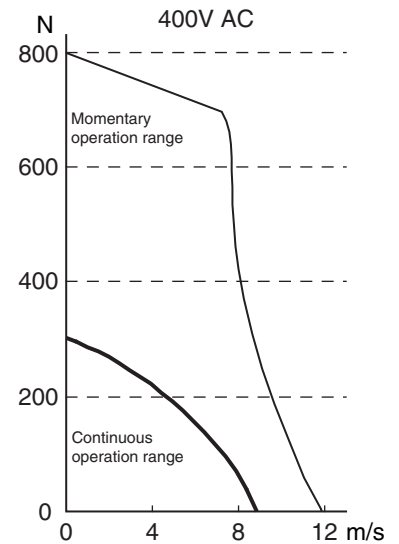
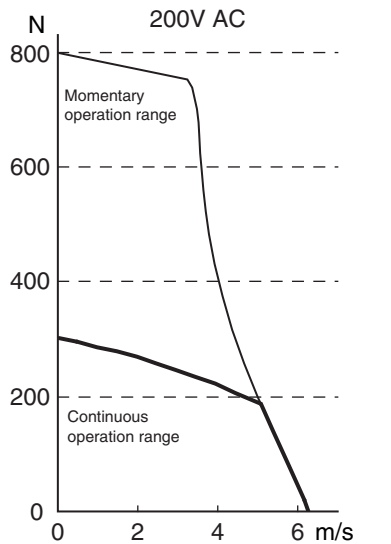
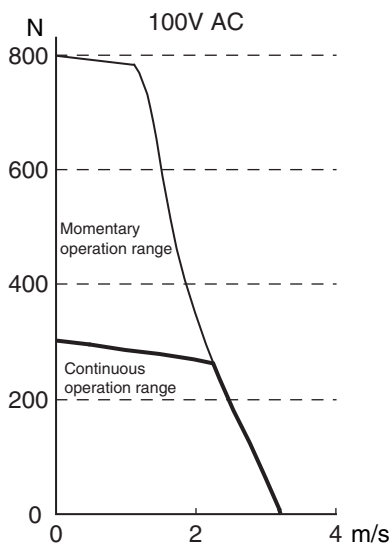

G5-Series
System Configuration

EtherCAT Communications
AC Servo Drive

EtherCAT Communications
Linear Motor Type
AC Servo Drive

General-purpose Inputs
AC Servo Drive

ML-II Type
AC Servo Drive

AC Servomotors

Linear Motor

R88L-EC-FW-1112

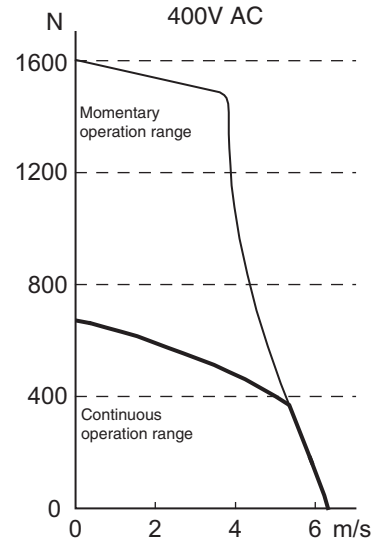
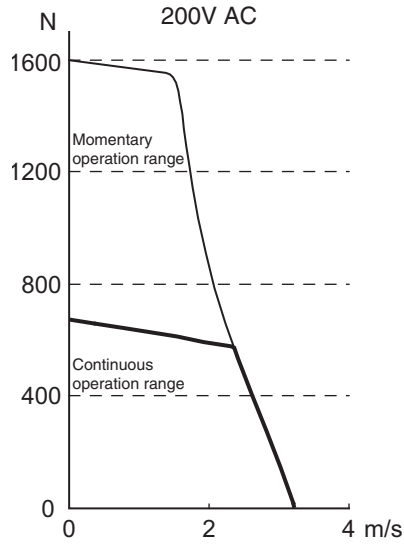
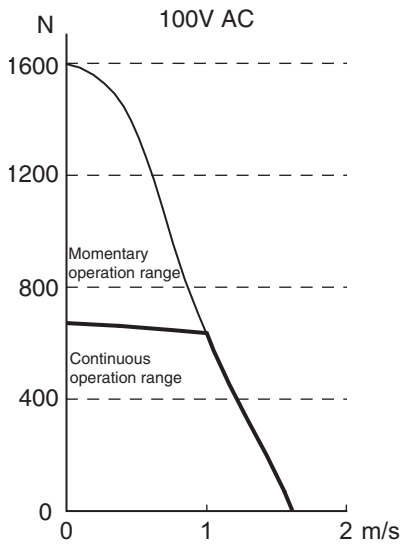

R88L-EC-FW-1115

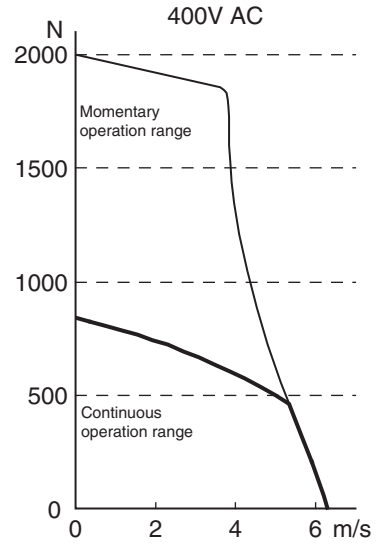
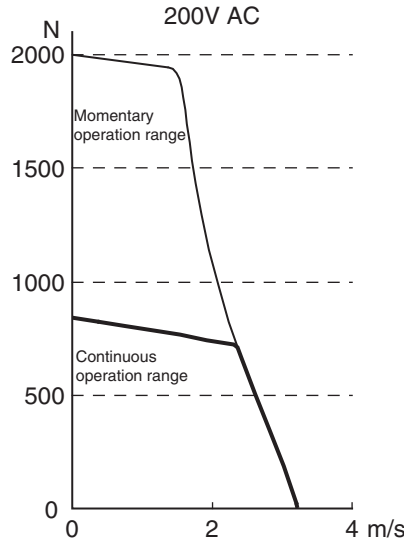
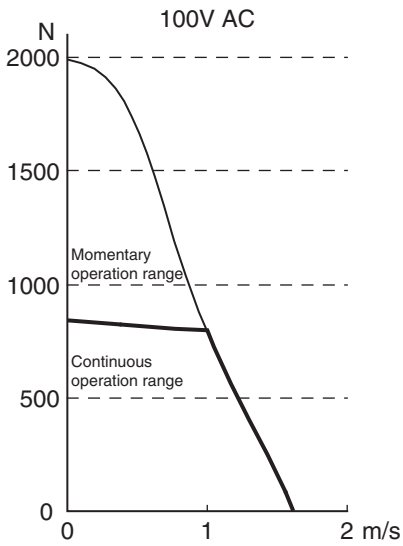

● Ironless Linear Motors

Item	Unit	R88L-EC-									
		GW-0303 -ANPS		GW-0306 -ANPS	GW-0309 -ANPS	GW-0503 -ANPS	GW-0506 -ANPS	GW-0509 -ANPS	GW-0703 -ANPS	GW-0706 -ANPS	GW-0709 -ANPS
Maximum speed (100VAC)	m/s	8	-	8	-	2.2	2.2	2.2	1.2	1.2	-
Maximum speed (200VAC)	m/s	-	16	16	16	4.4	4.4	4.4	2.4	2.4	2.4
Continuous force*1	N	26.5		53	80	58	117	175	117	232	348
Momentary maximum force*2	N	100	96	200	300	240	480	720	552	1110	1730
Continuous current*2	Arms	1.33		2.66	4.0	0.87	1.76	2.60	0.94	1.87	2.81
Momentary maximum current*1	Arms	5.0	4.8	10.0	15.0	3.50	7.1	10.6	4.5	9.0	14
Motor force constant	N/Arms	19.9		19.9	19.9	68.0	68.0	68.0	124.0	124.0	124.0
Back electromotive force	V·s/m	6.6		6.6	6.6	22.7	22.7	22.7	41.3	41.3	41.3
Motor constant	N/√W	4.90		6.93	8.43	9.85	13.96	17.03	17.97	25.44	31.14
Phase resistance	Ω	5.5		2.8	1.8	15.9	8.0	5.3	15.8	7.9	5.3
Phase inductance	mH	1.8		0.9	0.6	13	6.5	4.2	28.0	14.0	9.0
Electrical time constant	ms	0.35		0.35	0.35	0.8	0.8	0.8	1.8	1.8	1.8
Maximum continuous power consumption	W	47		95	142	67	134	200	82	165	247
Thermal resistance	K/W	2.1		1.06	0.71	1.70	0.85	0.65	1.56	1.04	0.52
Thermal time constant	s	36		36	36	72	72	72	96	96	96
Magnetic attractive force	N	0		0	0	0	0	0	0	0	0
Magnetic pole pitch	mm	30		30	30	42	42	42	57	57	57
Mass (except cables)	kg	0.084		0.162	0.24	0.25	0.47	0.69	0.55	0.95	1.35
Application Servo Drives (R88D-□-ECT-L)		KN01L	KN02H	KN04L/ KN08H	KN10H	KN01L/ KN01H	KN02L/ KN04H	KN04L/ KN08H	KN02L/ KN04H	KN04L/ KN08H	KN10H
Magnet Trac (R88L-EC-)		GM-03090-A/GM-03120-A/ GM-03390-A				GM-05126-A/GM-05168-A/ GM-05210-A/GM-05546-A			GM-07114-A/GM-07171-A/ GM-07456-A		
Magnet Trac Unit Length	mm	90/120/390				126/168/210/546			114/171/456		

*1. This shows a value measured when the Motor Coil Unit is at 100°C and the Magnet Trac is at 25°C.

*2. The Motor Coil Unit is subjected to a temperature rise of 40 K/s.

G5-Series
System Configuration

EtherCAT Communications
AC Servo Drive

EtherCAT Communications
Linear Motor Type
AC Servo Drive

General-purpose Inputs
AC Servo Drive

ML-II Type
AC Servo Drive

AC Servomotors

Linear Motor

AC Servomotor/Drive G5-series

Speed - Force Characteristics

The maximum operation speed is limited by considering the guide mechanism, encoder, and other aspects. If it is 5 m/s or higher, please consult with your OMRON representative.

R88L-EC-GW-0303

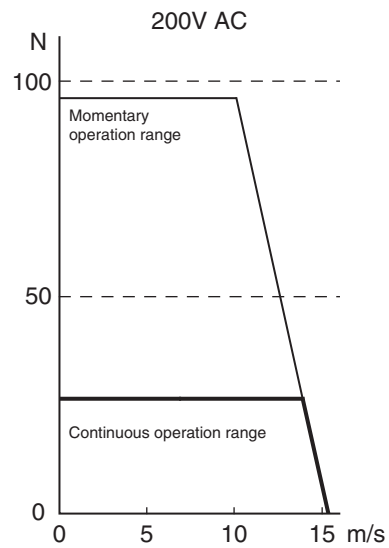
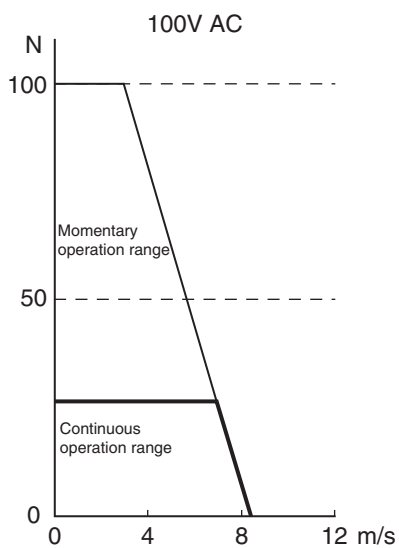

R88L-EC-GW-0306

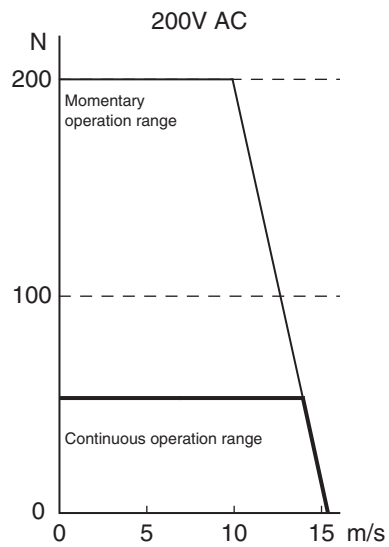
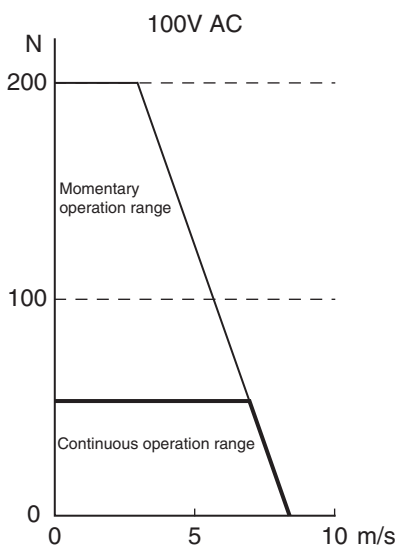

R88L-EC-GW-0309

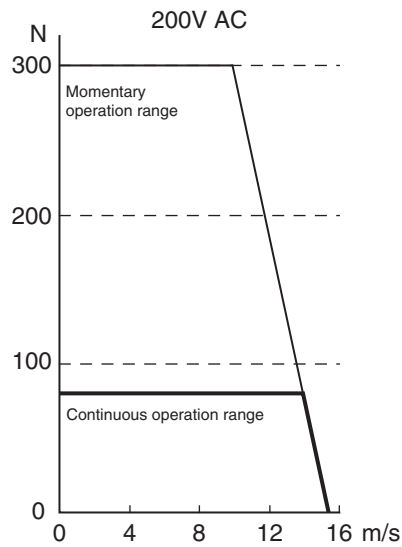
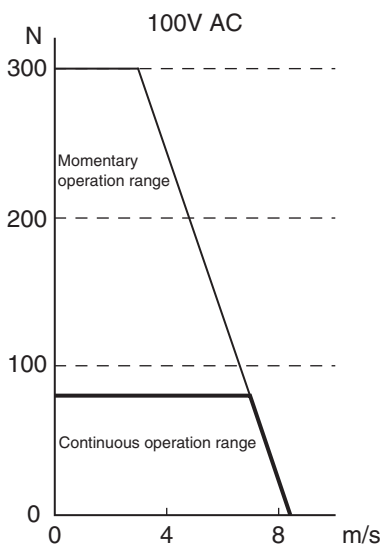

R88L-EC-GW-0503

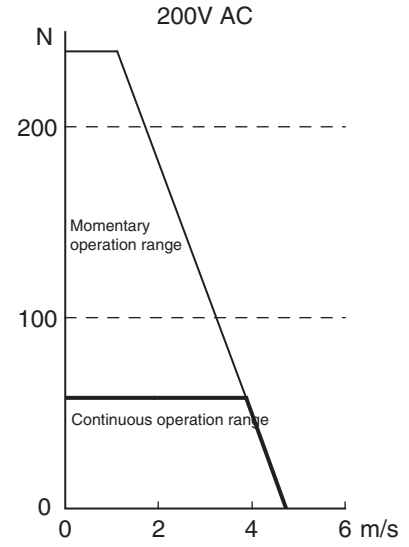
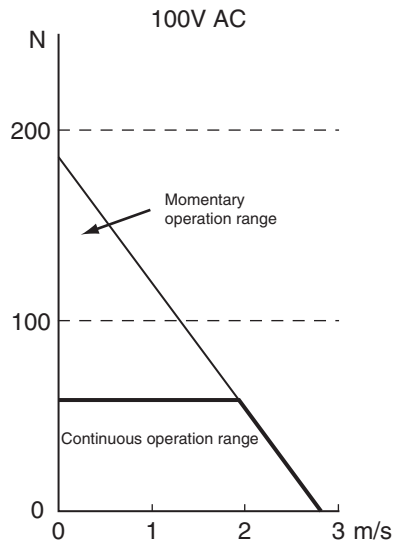

R88L-EC-GW-0506

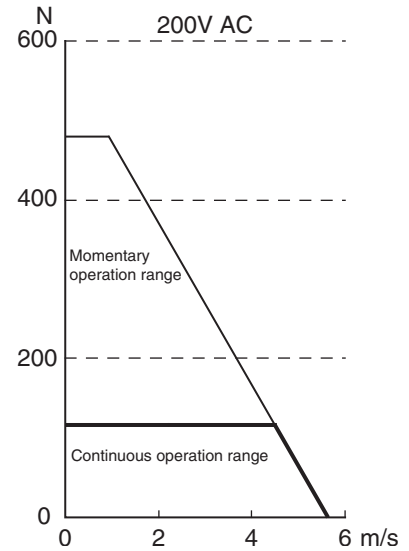
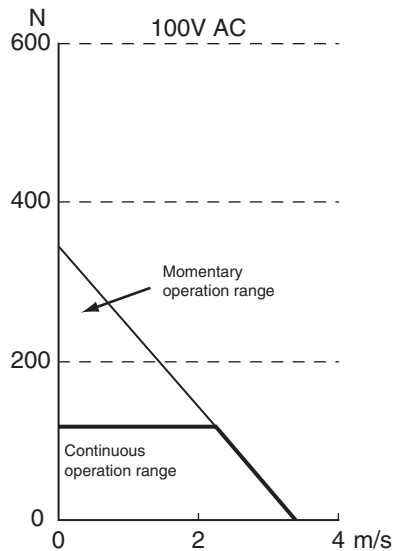

R88L-EC-GW-0509

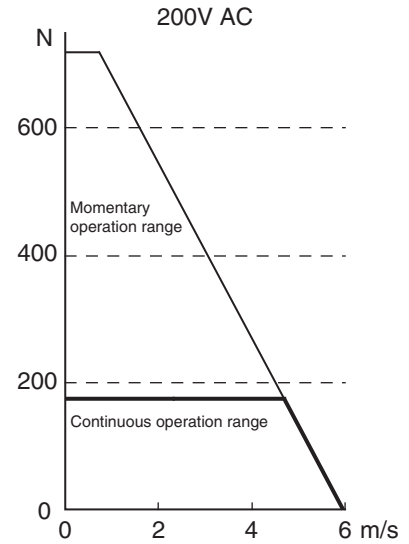
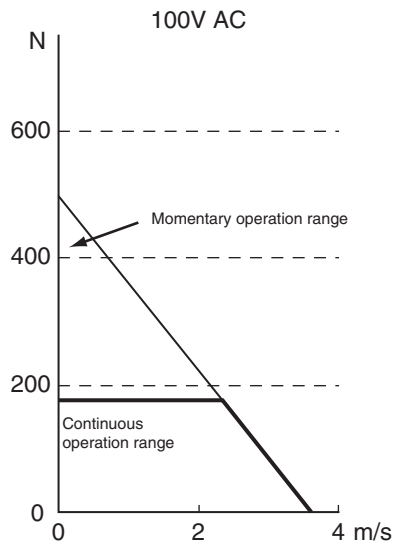

G5-Series
System Configuration

EtherCAT Communications
AC Servo Drive

EtherCAT Communications
Linear Motor Type
AC Servo Drive

General-purpose Inputs
AC Servo Drive

ML-II Type
AC Servo Drive

AC Servomotors

Linear Motor

R88L-EC-GW-0703

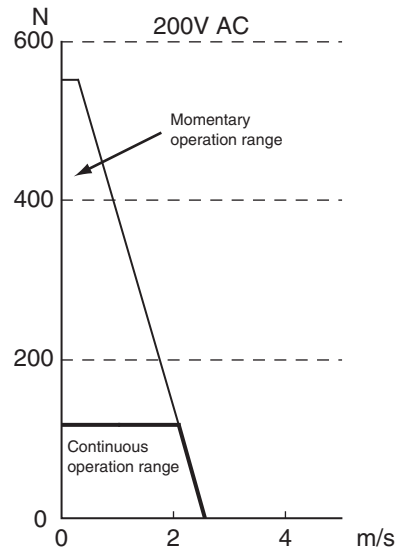
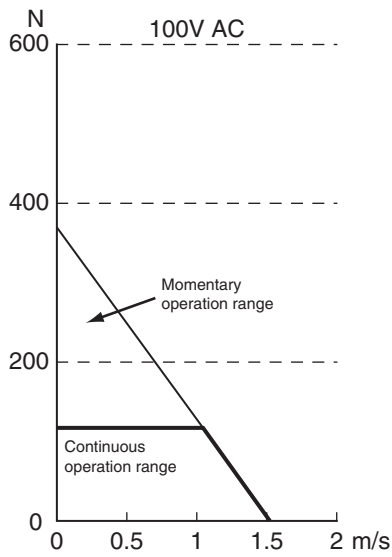

R88L-EC-GW-0706

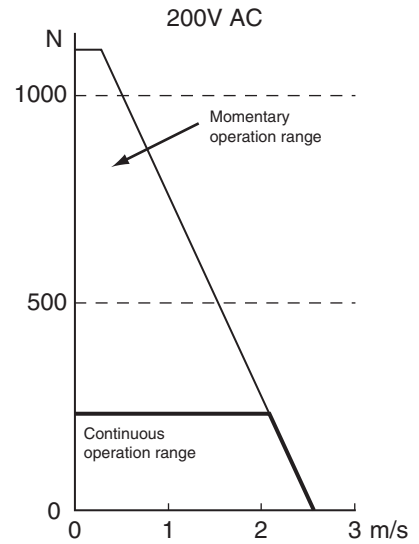
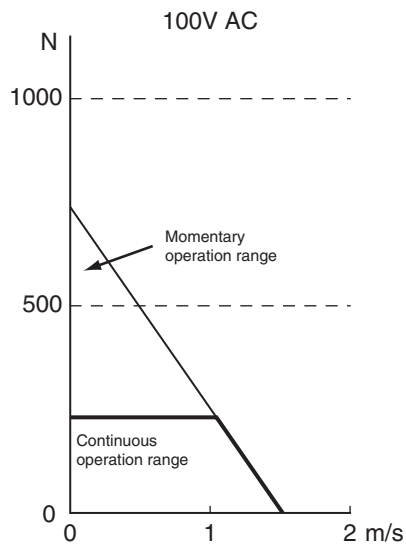

R88L-EC-GW-0709

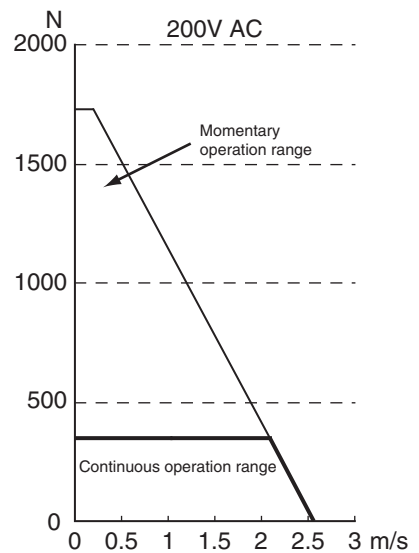
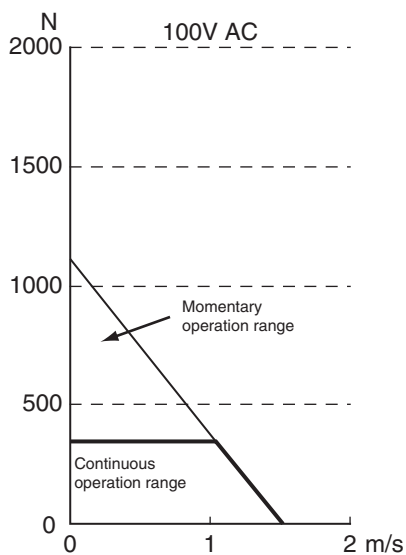

Dimensions

Iron-core Linear Motors

• Motor Coil Unit

- R88L-EC-FW-0303/0306

Model	L1 [mm]	Number of holes [N]	Mass[kg] *1
R88L-EC-FW-0303	79 +0.15/-0.35	4	0.72
R88L-EC-FW-0306	127 +0.15/-0.35	6	1.03

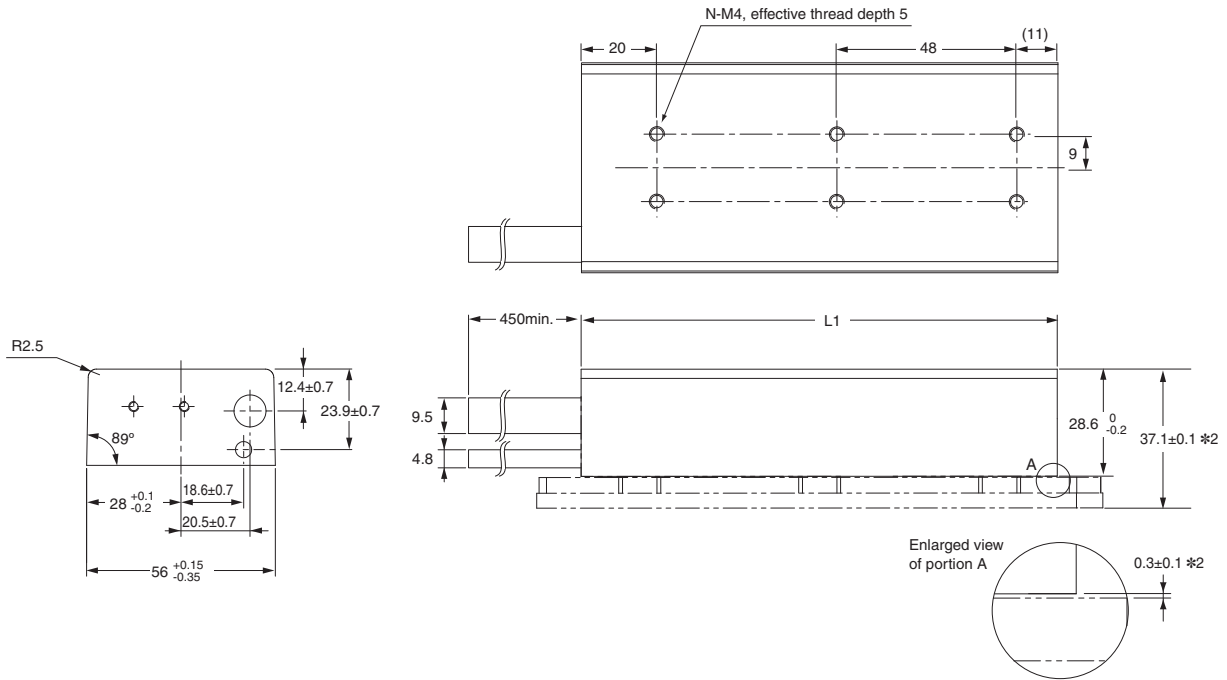

- *1. The weight of 450-mm cables is included.
- *2. These values indicate mounting dimensions.

• Magnet Trac

Model	L2 [mm]	L3 [mm]	Number of holes [N]	Mass [kg]
R88L-EC-FM-03096-A	96	48	4	Approx. 0.22
R88L-EC-FM-03144-A	144	96	6	Approx. 0.32
R88L-EC-FM-03384-A	384	336	16	Approx. 0.85

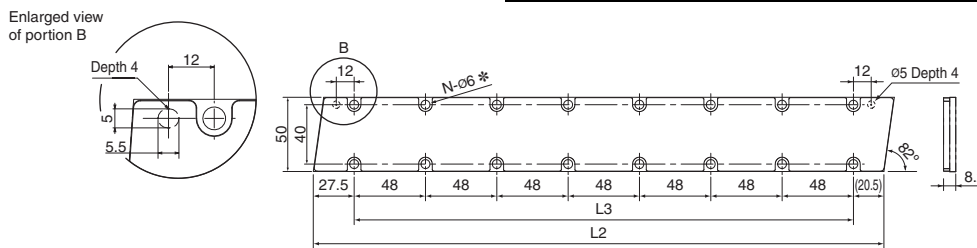

- * Use M5 low head allen head bolts.

• Motor Coil Unit

- R88L-EC-GW-0503/-0506/-0509

Model	L1 [mm]	L2 [mm]	Number of holes [N]	Mass [kg] *
R88L-EC-GW-0503	106	84	4	0.48
R88L-EC-GW-0506	190	168	7	0.71
R88L-EC-GW-0509	274	252	10	0.94

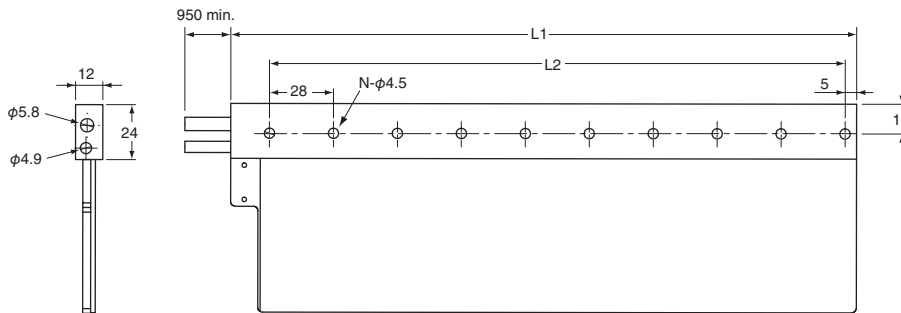

* The weight of 950-mm cables is included.

• Magnet Trac

Model	L3 [mm]	L4 [mm]	Number of holes [N]	Mass [kg]
R88L-EC-GM-05126-A	126	84	3	Approx. 1.49
R88L-EC-GM-05168-A	168	126	4	Approx. 1.98
R88L-EC-GM-05210-A	210	168	5	Approx. 2.47
R88L-EC-GM-05546-A	546	504	13	Approx. 6.43

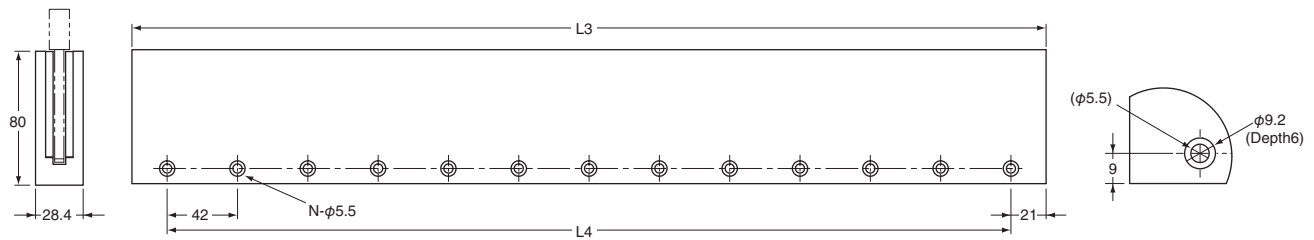

• Combination diagram

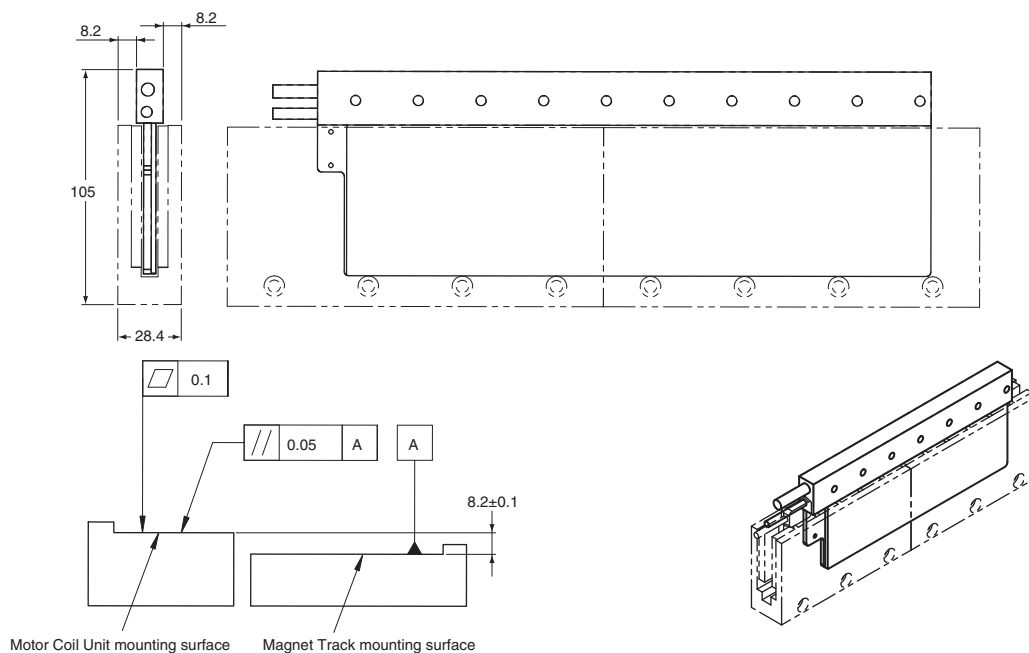

AC Servomotor/Drive G5-series

• Motor Coil Unit

• R88L-EC-GW-0703/-0706/-0709

Model	L1 [mm]	L2 [mm]	Number of holes [N]	Mass [kg] *
R88L-EC-GW-0703	134	114	4	0.9
R88L-EC-GW-0706	248	228	7	1.32
R88L-EC-GW-0709	362	342	10	1.74

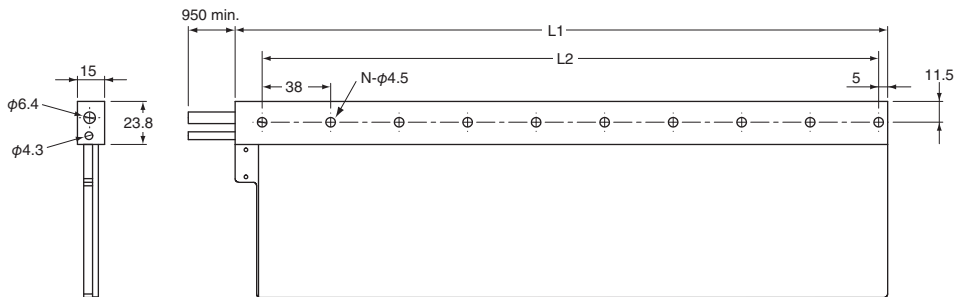

* The weight of 950-mm cables is included.

• Magnet Trac

Model	L3 [mm]	L4 [mm]	Number of holes [N]	Mass [kg]
R88L-EC-GM-07114-A	114	57	2	Approx. 2.88
R88L-EC-GM-07171-A	171	114	3	Approx. 4.31
R88L-EC-GM-07456-A	456	399	8	Approx. 11.5

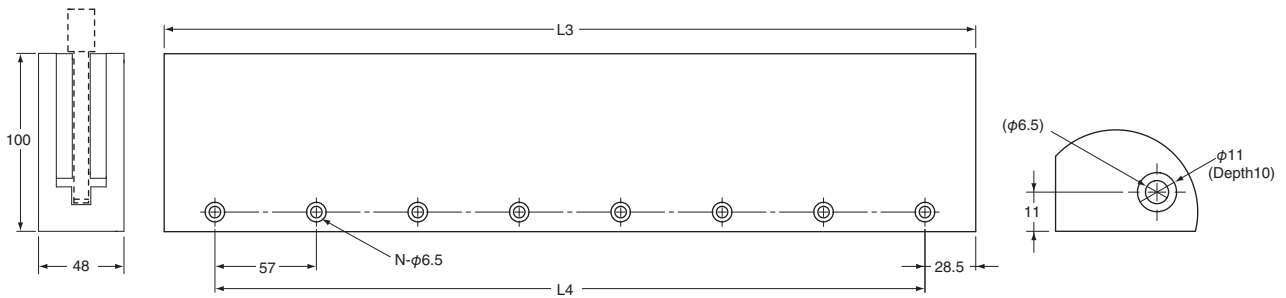

• Combination diagram

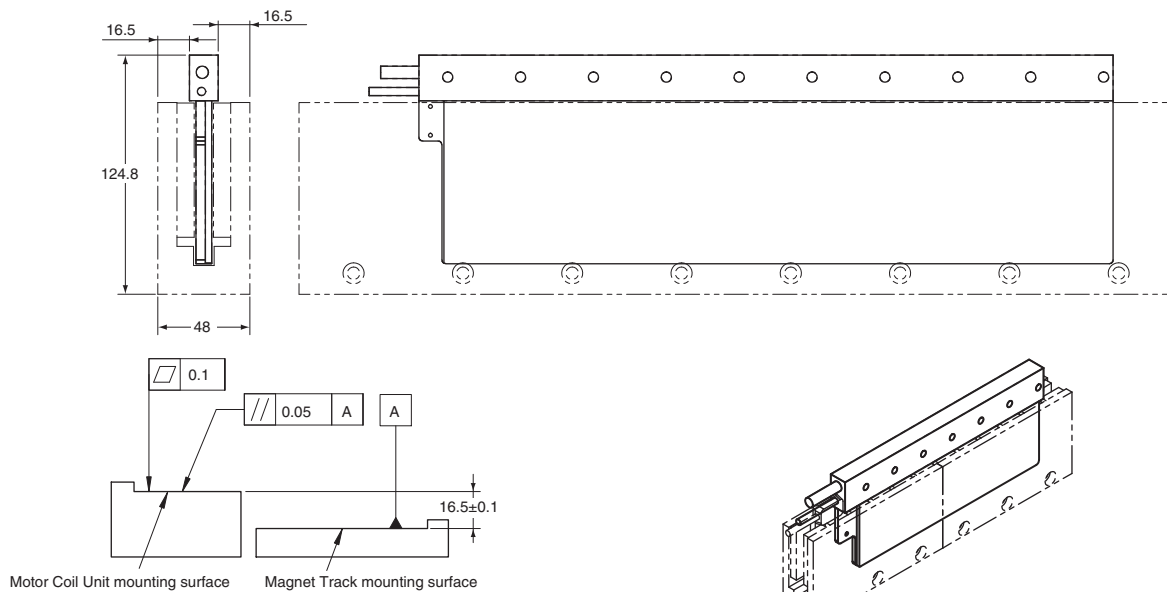

Related Manuals

Please read the relevant manuals of G5-Series

English Cat. No.	Japanese Cat. No.	Type	Name
I571	SBCE-357	R88D-KT/R88M-K	G5-SERIES AC SERVOMOTOR AND SERVO DRIVE USER'S MANUAL
I572	SBCE-358	R88D-KN□-ML2/R88M-K	G5-SERIES MECHATROLINK-II Communications AC SERVOMOTOR AND SERVO DRIVE USER'S MANUAL
I573	SBCE-360	R88D-KN□-ECT-R/R88M-K	G5-SERIES EtherCAT Communications for Position Control AC SERVOMOTOR AND SERVO DRIVE USER'S MANUAL
I576	SBCE-365	R88D-KN□-ECT/R88M-K	G5-SERIES EtherCAT Communications AC SERVOMOTOR AND SERVO DRIVE USER'S MANUAL
I577	SBCE-366	E88D-KN□-ECT-L/R88L-EC	G5-SERIES EtherCAT Communications Linear Motor Type LINEARMOTOR AND DRIVE USER'S MANUAL
W487	SBCE-359	CJ1W-NC□81/CJ1W-NC□82	CJ-series Position Control Unit Operation Manual
W446	SBCA-337	CXONE-AL□□C-V□-AL□□D-V□	CX-Programmer Operation Manual
W453	SBCE-375	CXONE-□□□□C-V□/□□□□D-V□	CX-Drive OPERATION MANUAL
W504	SBCA-362	SYSMAC-SE2□□□	Sysmac Studio Version 1 Operation Manual

G5-Series
System Configuration

EtherCAT Communications
AC Servo Drive

EtherCAT Communications
Linear Motor Type
AC Servo Drive

General-purpose Inputs
AC Servo Drive

ML-II Type
AC Servo Drive

AC Servomotors

Linear Motor

Read and Understand this Catalog

Please read and understand this catalog before purchasing the product. Please consult your OMRON representative if you have any questions or comments.

Warranty and Limitations of Liability

WARRANTY

OMRON's exclusive warranty is that the products are free from defects in materials and workmanship for a period of one year (or other period if specified) from date of sale by OMRON.

OMRON MAKES NO WARRANTY OR REPRESENTATION, EXPRESS OR IMPLIED, REGARDING NON-INFRINGEMENT, MERCHANTABILITY, OR FITNESS FOR PARTICULAR PURPOSE OF THE PRODUCTS. ANY BUYER OR USER ACKNOWLEDGES THAT THE BUYER OR USER ALONE HAS DETERMINED THAT THE PRODUCTS WILL SUITABLY MEET THE REQUIREMENTS OF THEIR INTENDED USE. OMRON DISCLAIMS ALL OTHER WARRANTIES, EXPRESS OR IMPLIED.

LIMITATIONS OF LIABILITY

OMRON SHALL NOT BE RESPONSIBLE FOR SPECIAL, INDIRECT, OR CONSEQUENTIAL DAMAGES, LOSS OF PROFITS OR COMMERCIAL LOSS IN ANY WAY CONNECTED WITH THE PRODUCTS, WHETHER SUCH CLAIM IS BASED ON CONTRACT, WARRANTY, NEGLIGENCE, OR STRICT LIABILITY.

In no event shall the responsibility of OMRON for any act exceed the individual price of the product on which liability is asserted.

IN NO EVENT SHALL OMRON BE RESPONSIBLE FOR WARRANTY, REPAIR, OR OTHER CLAIMS REGARDING THE PRODUCTS UNLESS OMRON'S ANALYSIS CONFIRMS THAT THE PRODUCTS WERE PROPERLY HANDLED, STORED, INSTALLED, AND MAINTAINED AND NOT SUBJECT TO CONTAMINATION, ABUSE, MISUSE, OR INAPPROPRIATE MODIFICATION OR REPAIR.

Application Considerations

SUITABILITY FOR USE

OMRON shall not be responsible for conformity with any standards, codes, or regulations that apply to the combination of products in the customer's application or use of the products.

At the customer's request, OMRON will provide applicable third party certification documents identifying ratings and limitations of use that apply to the products. This information by itself is not sufficient for a complete determination of the suitability of the products in combination with the end product, machine, system, or other application or use.

The following are some examples of applications for which particular attention must be given. This is not intended to be an exhaustive list of all possible uses of the products, nor is it intended to imply that the uses listed may be suitable for the products:

- Outdoor use, uses involving potential chemical contamination or electrical interference, or conditions or uses not described in this catalog.
- Nuclear energy control systems, combustion systems, railroad systems, aviation systems, medical equipment, amusement machines, vehicles, safety equipment, and installations subject to separate industry or government regulations.
- Systems, machines, and equipment that could present a risk to life or property.

Please know and observe all prohibitions of use applicable to the products.

NEVER USE THE PRODUCTS FOR AN APPLICATION INVOLVING SERIOUS RISK TO LIFE OR PROPERTY WITHOUT ENSURING THAT THE SYSTEM AS A WHOLE HAS BEEN DESIGNED TO ADDRESS THE RISKS, AND THAT THE OMRON PRODUCTS ARE PROPERLY RATED AND INSTALLED FOR THE INTENDED USE WITHIN THE OVERALL EQUIPMENT OR SYSTEM.

PROGRAMMABLE PRODUCTS

OMRON shall not be responsible for the user's programming of a programmable product, or any consequence thereof.

Disclaimers

CHANGE IN SPECIFICATIONS

Product specifications and accessories may be changed at any time based on improvements and other reasons. Consult with your OMRON representative at any time to confirm actual specifications of purchased product.

DIMENSIONS AND WEIGHTS

Dimensions and weights are nominal and are not to be used for manufacturing purposes, even when tolerances are shown.

PERFORMANCE DATA

Performance data given in this catalog is provided as a guide for the user in determining suitability and does not constitute a warranty. It may represent the result of OMRON's test conditions, and the users must correlate it to actual application requirements. Actual performance is subject to the OMRON Warranty and Limitations of Liability.

OMRON Corporation Industrial Automation Company

Tokyo, JAPAN

Contact: www.ia.omron.com

Regional Headquarters

OMRON EUROPE B.V.

Wegalaan 67-69-2132 JD Hoofddorp
The Netherlands
Tel: (31)2356-81-300/Fax: (31)2356-81-388

OMRON ELECTRONICS LLC

One Commerce Drive Schaumburg,
IL 60173-5302 U.S.A.
Tel: (1) 847-843-7900/Fax: (1) 847-843-7787

OMRON ASIA PACIFIC PTE. LTD.

No. 438A Alexandra Road # 05-05/08 (Lobby 2),
Alexandra Technopark,
Singapore 119967
Tel: (65) 6835-3011/Fax: (65) 6835-2711

OMRON (CHINA) CO., LTD.

Room 2211, Bank of China Tower,
200 Yin Cheng Zhong Road,
PuDong New Area, Shanghai, 200120, China
Tel: (86) 21-5037-2222/Fax: (86) 21-5037-2200

Authorized Distributor:

© OMRON Corporation 2009 All Rights Reserved.
In the interest of product improvement,
specifications are subject to change without notice.

CSM_8_1_1014
Cat. No. I816-E1-06

Printed in Japan
1012 (1109) (IT)

Mouser Electronics

Authorized Distributor

Click to View Pricing, Inventory, Delivery & Lifecycle Information:

Omron:

[R88D-KN01H-ECT](#) [R88D-KN01L-ECT](#) [R88D-KN02L-ECT](#) [R88D-KN04L-ECT](#) [R88D-KN06F-ECT](#) [R88D-KN08H-ECT](#) [R88D-KN10F-ECT](#) [R88D-KN10H-ECT](#) [R88D-KN150F-ECT](#) [R88D-KN15F-ECT](#) [R88D-KN15H-ECT](#) [R88D-KN20F-ECT](#) [R88D-KN20H-ECT](#) [R88D-KN30F-ECT](#) [R88D-KN30H-ECT](#) [R88D-KN50F-ECT](#) [R88D-KN50H-ECT](#) [R88D-KN75F-ECT](#) [R88D-KNA5L-ECT](#) [R88D-KT150F](#) [R88D-KT75F](#) [R88D-KT75H](#) [R88M-K11K015C-BS2](#) [R88M-K11K015C-S2](#) [R88M-K15K015C-S2](#) [R88M-K7K515C-BS2](#) [R88M-K7K515C-S2](#) [R88M-K7K515T-BS2](#) [R88M-K7K515T-S2](#)



Компания «ЭлектроПласт» предлагает заключение долгосрочных отношений при поставках импортных электронных компонентов на взаимовыгодных условиях!

Наши преимущества:

- Оперативные поставки широкого спектра электронных компонентов отечественного и импортного производства напрямую от производителей и с крупнейших мировых складов;
- Поставка более 17-ти миллионов наименований электронных компонентов;
- Поставка сложных, дефицитных, либо снятых с производства позиций;
- Оперативные сроки поставки под заказ (от 5 рабочих дней);
- Экспресс доставка в любую точку России;
- Техническая поддержка проекта, помощь в подборе аналогов, поставка прототипов;
- Система менеджмента качества сертифицирована по Международному стандарту ISO 9001;
- Лицензия ФСБ на осуществление работ с использованием сведений, составляющих государственную тайну;
- Поставка специализированных компонентов (Xilinx, Altera, Analog Devices, Intersil, Interpoint, Microsemi, Aeroflex, Peregrine, Syfer, Eurofarad, Texas Instrument, Miteq, Cobham, E2V, MA-COM, Hittite, Mini-Circuits, General Dynamics и др.);

Помимо этого, одним из направлений компании «ЭлектроПласт» является направление «Источники питания». Мы предлагаем Вам помощь Конструкторского отдела:

- Подбор оптимального решения, техническое обоснование при выборе компонента;
- Подбор аналогов;
- Консультации по применению компонента;
- Поставка образцов и прототипов;
- Техническая поддержка проекта;
- Защита от снятия компонента с производства.



Как с нами связаться

Телефон: 8 (812) 309 58 32 (многоканальный)

Факс: 8 (812) 320-02-42

Электронная почта: org@eplast1.ru

Адрес: 198099, г. Санкт-Петербург, ул. Калинина, дом 2, корпус 4, литера А.