

ISP4520

Smart LoRa and Bluetooth Low Energy Module with MCU and Antennas

This highly miniaturized LGA module, 9.8 x 17.2 x 1.7 mm, is based on the new SX126x LoRa transceiver series and nRF52832 BLE chip. Using a simple user interface via the SPI connection and integrating a Cortex™ M4 CPU, flash and RAM memory combined with single optimized antenna for both LoRa and BLE standards, ISP4520 offers the perfect stand-alone module solution for large spectrum of application in IoT domains. For longer range use case, ISP4520 can be used in conjunction with an external LoRa antenna.



Key Features

- LoRaWAN Protocol Stack
- Single Mode BLE 5 Ready
- NFC-A Tag for OOB pairing
- Fully integrated LoRa & BLE matching and Antennas
- Integrated LoRa and BLE 32 MHz & 32.768 kHz Clocks
- LoRa section based on Semtech SX126x series transceiver
- BLE section based on Nordic Semi nRF52
- Externally Controlled or using embedded 32-bit ARM Cortex M4 CPU
- 512 kB Flash and 64 kB SRAM
- Analog and Digital peripherals
- SPI interface
- Supply Voltage 1.8V to 3.6V
- Very small size 9.8 x 17.2 x 1.7 mm
- Temperature -30 to +85 °C



Applications

- Smart Cities / Smart Retail
- Industrial Internet
- Big Data / Data Science
- Energy Engagement / Smart grids

Certifications

- FCC certification pending
- CE certification pending
- LoRaWAN certification pending
- Bluetooth SIG certification pending
- RoHS compliant

Revision History

Revision	Date	Ref	Change Description
R0	25/01/2018	hc pg	Preliminary release
R1	17/05/2018	hc pg	Engineering sample release
R2	05/07/2018	hc pg	Schematic & IO changes
R3	21/02/2019	hc pg	RF performance update
R4	16/10/2019	jf pg	RF specification update, addition of §5 and §6
R5	13/02/2020	nw pg	JP version extended to Asia Pacific zone, called AS

Contents

1.	Block Diagram	4
2.	Specifications	5
2.1.	Important Notice	5
2.2.	Absolute Maximum Ratings	5
2.3.	Operating Conditions	5
2.4.	Current Consumption	6
2.5.	Clock Sources	6
2.6.	LoRa Radio Specifications	6
2.7.	BLE Radio Specifications	8
2.8.	Antenna Performance.....	8
2.9.	Electrical Schematic	11
2.10.	Internal Module Connections	14
3.	Pin Description	15
4.	Mechanical Outlines	17
4.1.	Mechanical Dimensions	17
4.2.	SMT Assembly Guidelines.....	19
4.3.	Antenna Keep-Out Zone.....	19
5.	Product Development Tools	20
5.1.	Hardware	20
5.2.	Firmware	20
5.3.	Development Tools.....	21
5.4.	LoRa Rx/Tx Switch Control.....	21
6.	Reference Design	23
6.1.	Sensor Board Design	23
7.	Packaging & Ordering information	26
7.1.	Marking	26
7.2.	Prototype Packaging	26
7.3.	Jedec Trays.....	26
7.4.	Tape and Reel.....	27
7.5.	Ordering Information.....	27
8.	Storage & Soldering information	28
8.1.	Storage and Handling	28
8.2.	Moisture Sensitivity.....	28
8.3.	Soldering information.....	29
9.	Quality & User information	30
9.1.	Pending Certifications.....	30
9.2.	USA – User information	30
9.3.	Canada – User information	30
9.4.	RF Exposure Information	31
9.5.	Informations concernant l'exposition aux fréquences radio (RF)	31
9.6.	Discontinuity.....	31
9.7.	Disclaimer	32

1. Block Diagram

This module is based on the Semtech SX126x single-chip LoRa transceiver series and the nRF52832 Nordic Semiconductor 2.4GHz wireless System on Chip (SoC). It integrates a 32-bit ARM Cortex™ M4F CPU, flash memory as well as analog and digital peripherals.

ISP4520 can support LoRa connectivity compliant to LoRa Alliance standards. LoRa section can be used as a stand-alone transmitting module connected to a LoRaWAN network for long range communication; or in a private LoRa network. SX1261 chipset is used for EU and AS variants, SX1262 for US variant.

ISP4520 also integrates a BLE connectivity compliant to Bluetooth V4.2. It can be used either in Peripheral or Central roles for BLE. Fully qualified BLE stacks for nRF52832 are implemented in the S132 SoftDevice which can be freely downloaded.

Despite the small size of 9.8 x 17.2 x 1.7 mm, the module integrates decoupling capacitors, 32 MHz crystals for LoRa and BLE and 32.768 kHz crystal for BLE, DC-DC converters in addition to the wireless SoCs. On the RF side, the ISP4520 also integrates the matching circuits for LoRa and BLE transmitters and receivers, a switch for Rx/Tx LoRa transmissions and a diplexer with common antenna for LoRa and BLE operation. Ultra-low power consumption and advanced power management enables battery lifetimes up to several years on a coin cell battery.

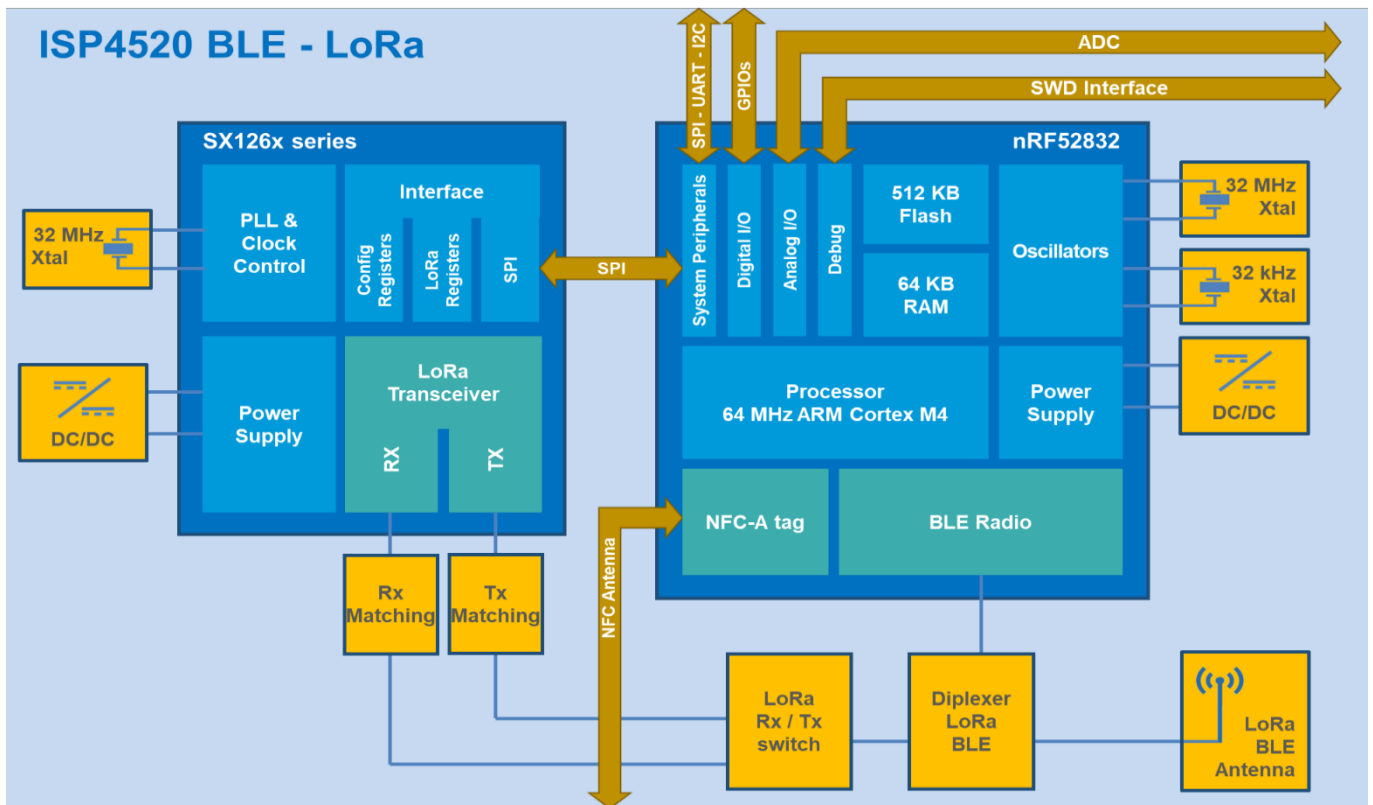

2. Specifications

2.1. Important Notice

The electrical specifications of the module are directly related to the Semtech SX126x series transceiver and the Nordic Semiconductor nRF52832 specifications for chipsets. The information below is only a summary of the main parameters. For more detailed information, please refer to the up-to-date specification of chipsets available on Semtech and Nordic Semi website.

The LoRa part of the modules is designed to work according to the LoRaWan specifications. The module functionalities and performances are tested with bandwidths of 125 kHz to 500 kHz. They are not guaranteed with lower bandwidths.

2.2. Absolute Maximum Ratings

Parameter	Min	Typ	Max	Unit
Supply Voltage VCC	-0.3		3.6	V
IO & Control Pins	-0.3		3.6	V
Storage Temperature	-40		+85	°C
Module Total Capacity			16	µF
Module Total Inductance			25	µH
Moisture Sensitivity Level			5	-
Flash Endurance			10000	cycles

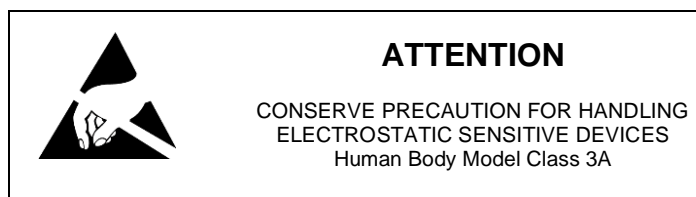

2.3. Operating Conditions

Parameter	Min	Typ	Max	Unit
Operating Supply Voltage VCC	1.8	3.0	3.6	V
Operating Input Voltage IO Pins P0.xx / GPIO	-0.3		VCC	V
Operating Temperature Range	-30	+25	+85	°C

2.4. Current Consumption

Parameter	Min	Typ	Max	Unit
LoRa current, Receiver active ⁽¹⁾		4.6		mA
LoRa current, Transmitter active, EU and AS variant ⁽²⁾		25.5		mA
LoRa current, Transmitter active, US variant ⁽³⁾		118		mA
LoRa standby mode, no oscillator active		0.6		mA
LoRa sleep mode, no warm start		600		nA
LoRa off mode		160		nA
BLE Peak current, Receiver active ⁽⁴⁾		6.1		mA
BLE Peak current, Transmitter active +4 dBm Output Power ⁽⁵⁾		7.9		mA
BLE Peak current, Transmitter active 0 dBm Output Power ⁽⁵⁾		5.4		mA
CPU System OFF current, no RAM retention		0.7		µA
CPU System ON base current, full RAM retention		1.5		µA
CPU Additional RAM retention current per 4 KB block		40		nA

- (1) DC-DC enabled, Power supply 3.3V, LoRa 125kHz
 (2) DC-DC enabled, Power supply 3.3V, Output power +14 dBm
 (3) DC-DC enabled, Power supply 3.3V, Output power +22 dBm
 (4) DC-DC enabled, Power supply 3V, 1 Mbps
 (5) DC-DC enabled, Power supply 3V

2.5. Clock Sources

Parameter	Min	Typ	Max	Unit
Internal High Frequency Clock for RF Stability: 32 MHz Crystal Frequency Tolerance ⁽¹⁾			± 40	ppm
Internal Low Frequency Clock for BLE Synchronization: 32.768 kHz Crystal Frequency Tolerance ⁽¹⁾			± 40	ppm
Internal Low Frequency Clock for BLE Synchronization: RC Oscillator ⁽²⁾			± 250	ppm

- (1) Including initial tolerance, drift, aging, and frequency pulling
 (2) Frequency tolerance after calibration

2.6. LoRa Radio Specifications

The ISP4520 is designed to be used in the upper ISM Bands in the region 800 – 900 Mhz. There are currently three variations of the ISP4520, aimed at different markets. The key differences between the products are the central frequency band that they are tuned for, and the output power that they are capable of.

EU version

It can be used in European Union countries, India, Russia and most of the Middle East and Africa.

Parameter - EU version	Min	Typ	Max	Unit
LoRa Frequency Band (EU)	863		870	MHz
LoRa Rx sensitivity Level for BER <1% ⁽³⁾	-137			dBm
LoRa Output Power at transceiver output		+14		dBm
LoRa Antenna Gain in band ^{(1) (5)}		-2.6		dBi
LoRa Load impedance		50		Ω
LoRa Range Open field @ 1 m height ^{(1) (3) (5)}		15		km
LoRa Range Open field @ 1 m height ^{(2) (3)}		20		km

US version

It is tuned to operate in the United States, in Canada and most of South America.

Parameter - US version	Min	Typ	Max	Unit
LoRa Frequency Band (US)	902		928	MHz
LoRa Rx sensitivity Level for BER <1% ⁽⁴⁾	-137			dBm
LoRa Output Power at transceiver output		+22		dBm
LoRa Antenna Gain in band ^{(1) (5)}		-1.9		dBi
LoRa Load impedance		50		Ω
LoRa Range Open field @ 1 m height ^{(1) (3) (5)}		17		km
LoRa Range Open field @ 1 m height ^{(2) (3)}		20		km

AS version

It is tuned to be used in Asia-Pacific countries including Japan, Korea, Taiwan and Australia.

Parameter - AS version	Min	Typ	Max	Unit
LoRa Frequency Band (AS)	920		923	MHz
LoRa Rx sensitivity Level for BER <1% ⁽³⁾	-137			dBm
LoRa Output Power at transceiver output		+14		dBm
LoRa Antenna Gain in band ^{(1) (5)}		-1.9		dBi
LoRa Load impedance		50		Ω
LoRa Range Open field @ 1 m height ^{(1) (3) (5)}		13		km
LoRa Range Open field @ 1 m height ^{(2) (3)}		16		km

(1) With internal LoRa antenna / Outdoor

(2) With external LoRa antenna / Outdoor

(3) Lower data rate DR0 SF12/125kHz, Rx boosted gain

(4) Lower data rate DR0 SF10/125kHz, Rx boosted gain

(5) Measured Front side of ISP4520

2.7. BLE Radio Specifications

Parameter	Min	Typ	Max	Unit
BLE Frequency Range	2402		2480	MHz
BLE Channel 0 to 39 Spacing		2		MHz
BLE Output Power Channels 0 to 39	-20		+4	dBm
BLE Rx sensitivity Level for BER <0,1% ideal Tx	-96			dBm
BLE Antenna Gain		-3.6		dBi
BLE EIRP	-23.6		0.4	dBm
BLE Range Open field @1m height (1)		70		m

(1) Data Rate 1000 / 2000 Kbps

2.8. Antenna Performance

LoRa Radiation Pattern – Module in top left corner

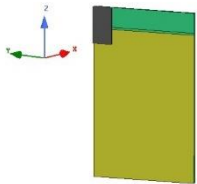

Module positioned on the top left corner of the application PCB (top view)
Keep out zone of 50 mm length
Ground plane of 70 x 50 mm

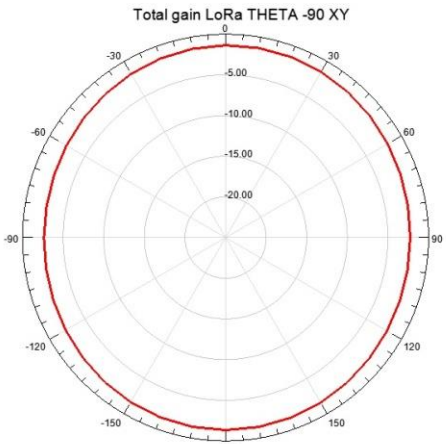
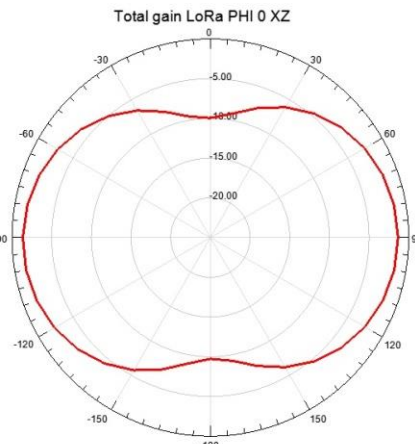
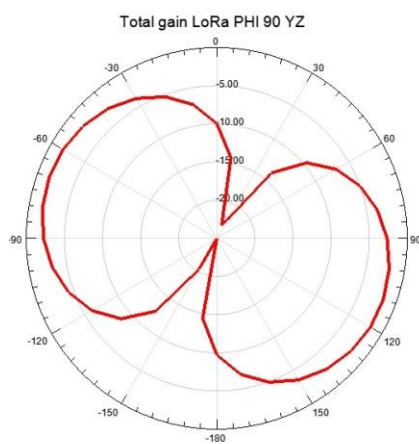
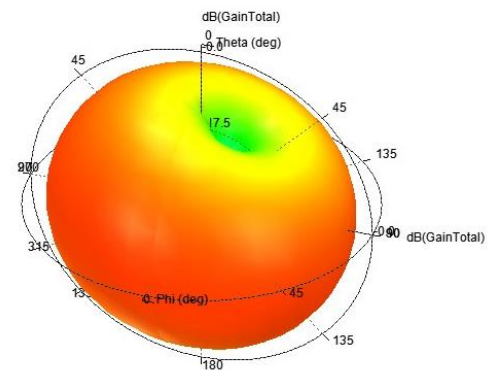

LoRa Radiation Pattern – Module in top center edge

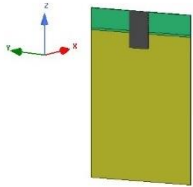

Module positioned on the center of the top edge of the application PCB (top view)
Keep out zone of 50 mm length
Ground plane of 70 x 50 mm

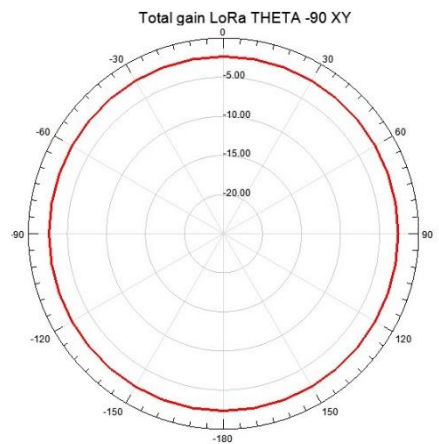
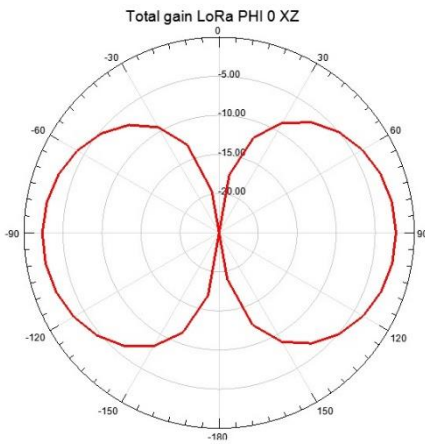
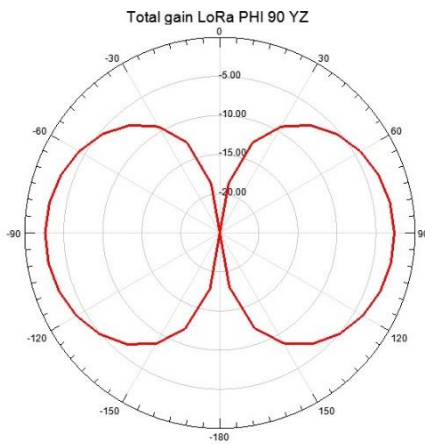
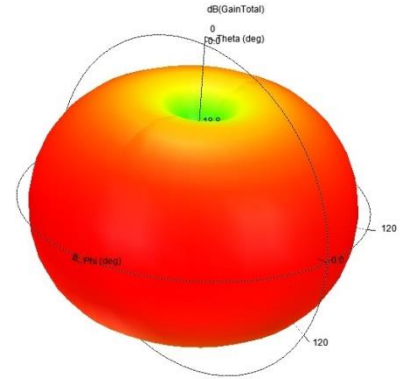

Ground Plane Effect Simulation

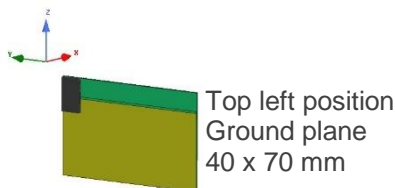
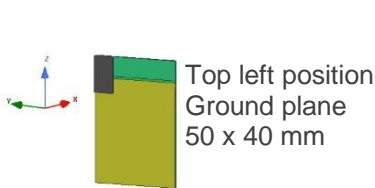
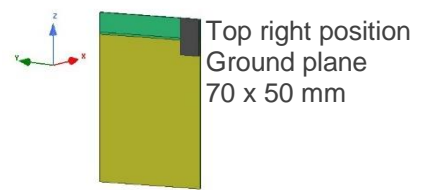
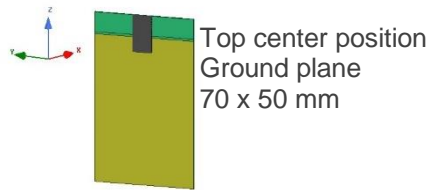
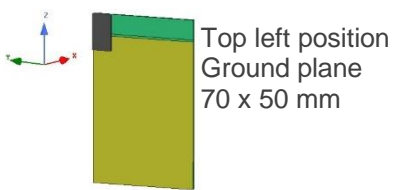

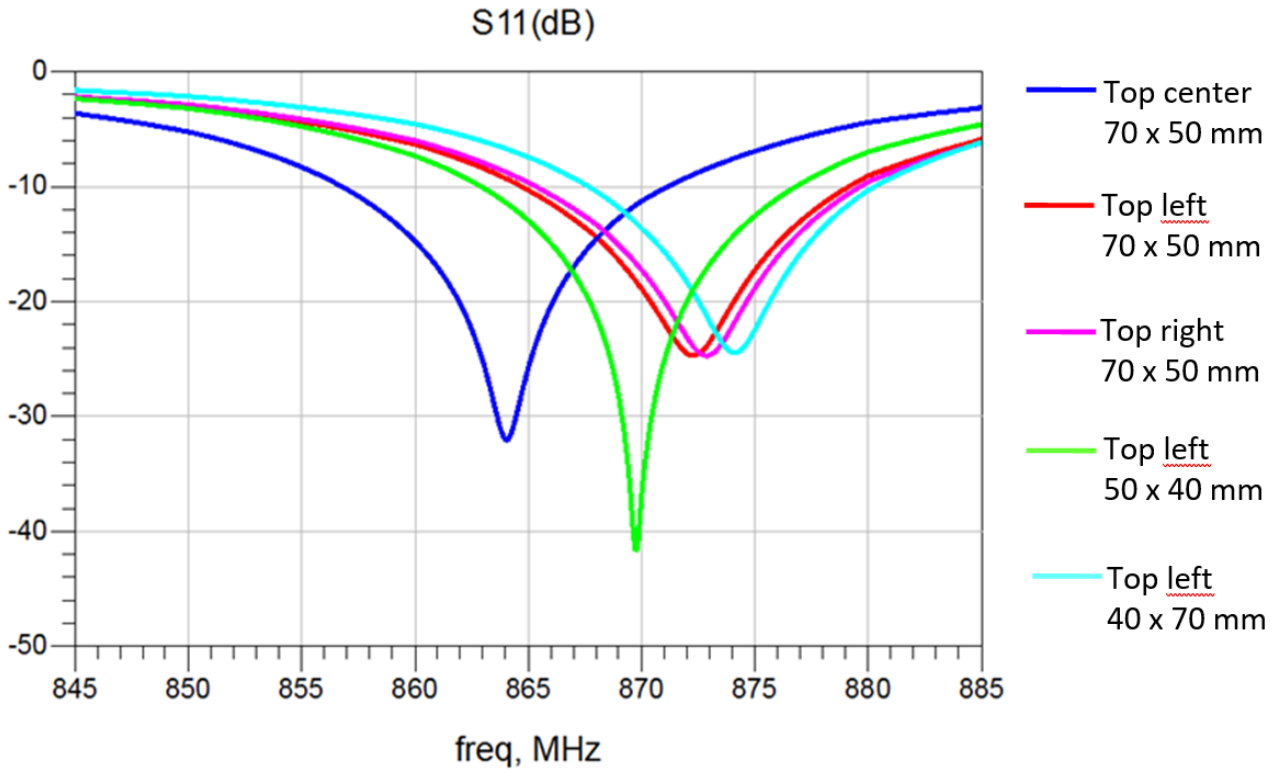

Details of Semtech LoRa transceiver connections for US version, based on SX1262

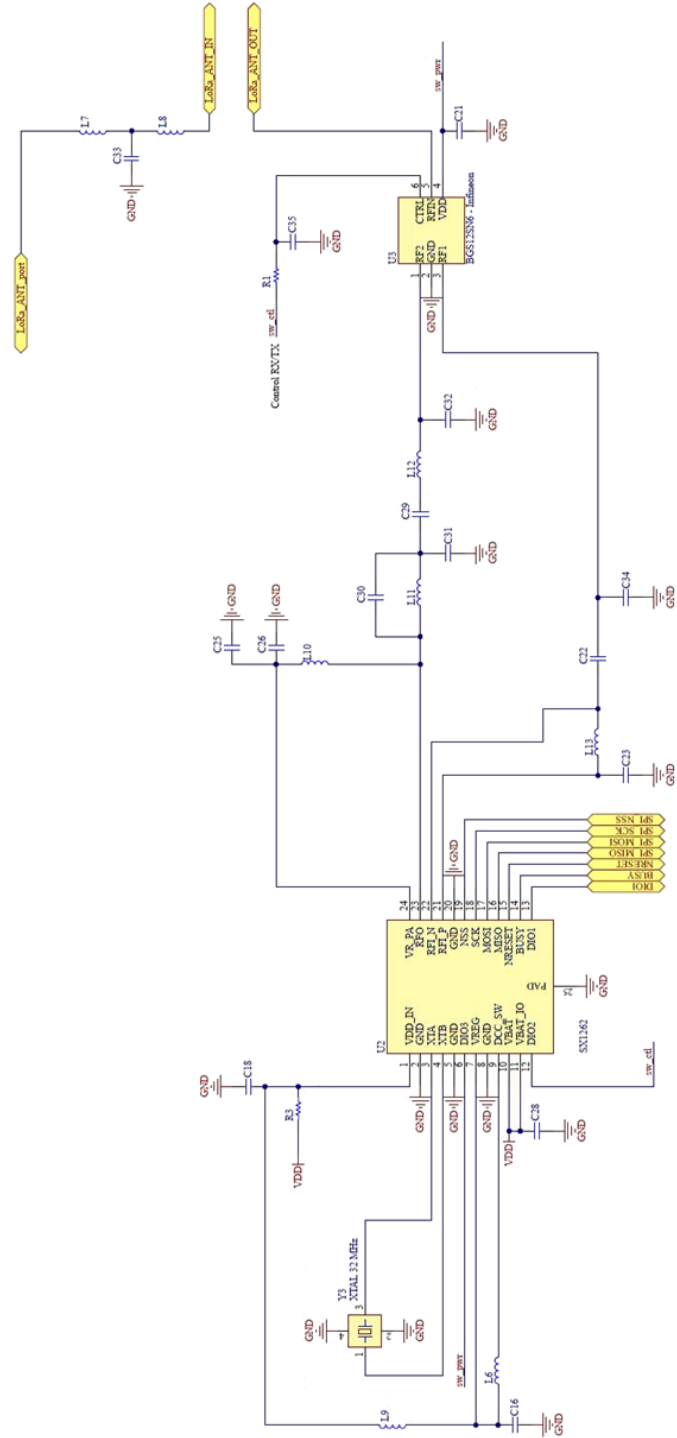

Details of nRF52832 connections, based on nRF52832

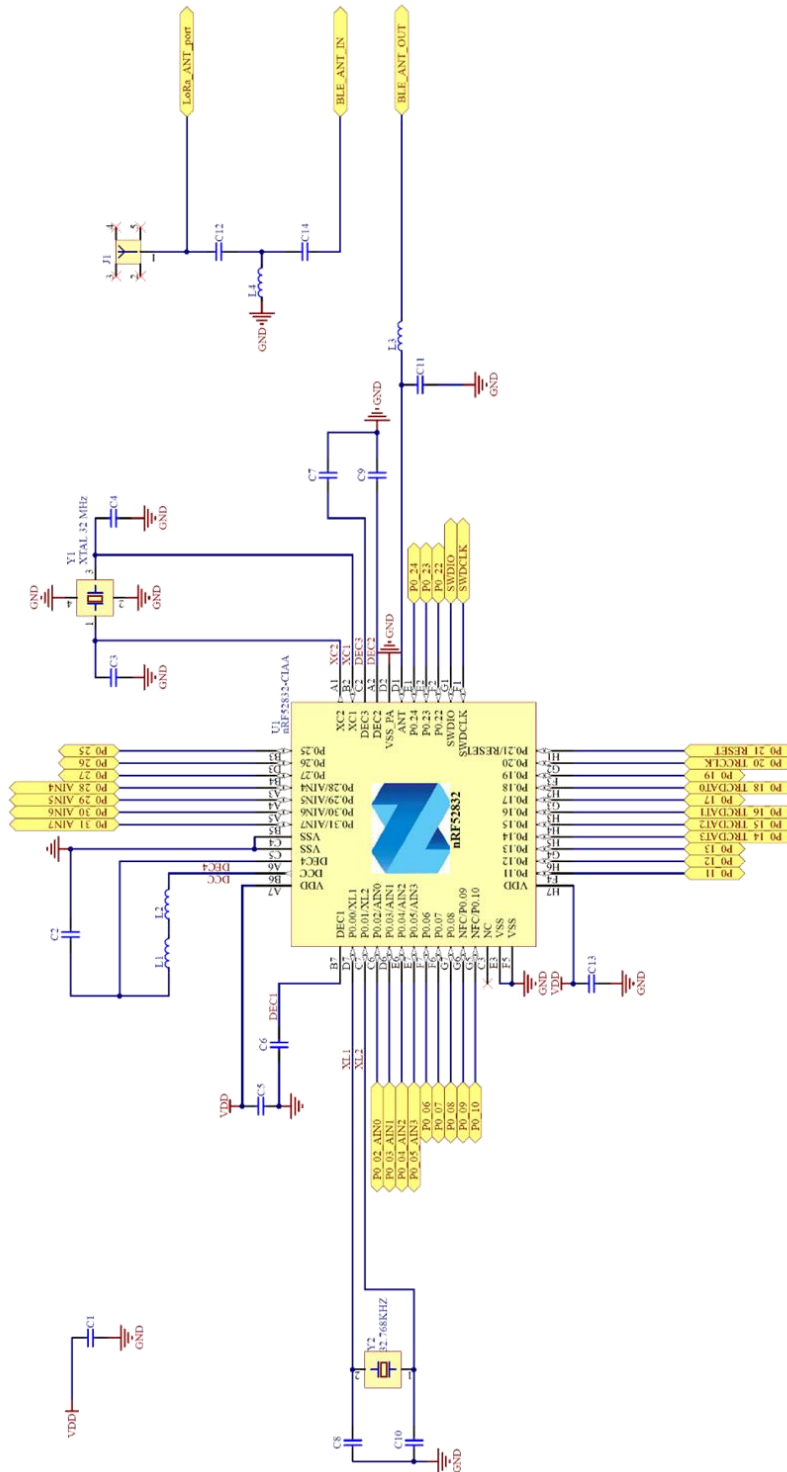

2.10. Internal Module Connections

The following nRF52 pins are used to communicate with the SX126x and therefore must not be configured to do anything else.

nRF Pin name	SX126x Pin name	Description
P0.11	DIO1	IRQ
P0.19	NRESET	Reset signal, active low
P0.23	SCK	SPI clock
P0.24	NSS	SPI Slave Select
P0.25	MISO	SPI master input
P0.26	MOSI	SPI master output
P0.27	BUSY	Busy indicator

3. Pin Description

The module uses an LGA format. The pad layout follows the QFN Jedec standard for LGA parts. The NC pads are to be connected to isolated metal pads on the application PCB for mechanical stability and reliability (drop test).

Pin	Name	Pin function	Description
1	GND	Ground	Power Ground – Must be connected to ground on application PCB
2	P0_12	Digital I/O	nRF52 general purpose I/O pin
3	P0_10 NFC2	Digital I/O NFC Input	nRF52 general purpose I/O pin NFC antenna connection pin
4	P0_17	Digital I/O	nRF52 general purpose I/O pin
5	P0_07	Digital I/O	nRF52 general purpose I/O pin
6	P0_22	Digital I/O	nRF52 general purpose I/O pin
7	P0_09 NFC1	Digital I/O NFC Input	nRF52 general purpose I/O pin NFC antenna connection pin
8	P0_08	Digital I/O	nRF52 general purpose I/O pin
9	P0_13	Digital I/O	nRF52 general purpose I/O pin
10	P0_06	Digital I/O	nRF52 general purpose I/O pin
11	P0_05_AIN3	Digital I/O Analog Input	nRF52 general purpose I/O pin SAADC / COMP / LPCOMP input
12	P0_04_AIN2	Digital I/O Analog Input	nRF52 general purpose I/O pin SAADC / COMP / LPCOMP input
13	P0_03_AIN1	Digital I/O Analog Input	nRF52 general purpose I/O pin SAADC / COMP / LPCOMP input
14	GND	Ground	Power Ground – Must be connected to ground on application PCB
15	VDD	Power	External supply
16	P0_02_AIN0	Digital I/O Analog Input	nRF52 general purpose I/O pin SAADC / COMP / LPCOMP input
17	P0_31_AIN7	Digital I/O Analog Input	nRF52 general purpose I/O pin SAADC / COMP / LPCOMP input
18	P0_30_AIN6	Digital I/O Analog Input	nRF52 general purpose I/O pin SAADC / COMP / LPCOMP input
19	P0_29_AIN5	Digital I/O Analog Input	nRF52 general purpose I/O pin SAADC / COMP / LPCOMP input
20	P0_28_AIN4	Digital I/O Analog Input	nRF52 general purpose I/O pin SAADC / COMP / LPCOMP input
21	GND	Ground	Power Ground – Must be connected to ground on application PCB
22	GND	Ground	Power Ground – Must be connected to ground on application PCB
23	GND	Ground	Power Ground – Must be connected to ground on application PCB
24	LoRa_TR	RF I/O	LoRa RF I/O pin of the module Should be connected to Pin 25 for normal operation
25	LoRa_ANT	RF I/O	Internal LoRa antenna RF I/O pin Should be connected to Pin 24 for normal operation
26	GND	Ground	Power Ground – Must be connected to ground on application PCB
27	GND	Ground	Power Ground – Must be connected to ground on application PCB
28	GND	Ground	Power Ground – Must be connected to ground on application PCB
29	GND	Ground	Power Ground – Must be connected to ground on application PCB
30	GND	Ground	Power Ground – Must be connected to ground on application PCB

Pin	Name	Pin function	Description
31	GND	Ground	Power Ground – Must be connected to ground on application PCB
32	GND	Ground	Power Ground – Must be connected to ground on application PCB
33	GND	Ground	Power Ground – Must be connected to ground on application PCB
34	BLE_ANT	RF I/O	Internal BLE antenna RF I/O pin Should be connected to Pin 35 for normal operation
35	BLE_TR	RF I/O	BLE RF I/O pin of the module Should be connected to Pin 34 for normal operation
36	GND	Ground	Power Ground – Must be connected to ground on application PCB
37	SWDCLK	Digital I/O	nRF52 Serial Wire Debug clock input for debug and programming
38	SWDIO	Digital I/O	nRF52 Serial Wire Debug I/O for debug and programming
39	P0_20 TRCCLK	Digital I/O	nRF52 general purpose I/O pin Trace port clock output
40	P0_21 RESET	Digital I/O	nRF52 general purpose I/O pin May be configured as nRF52 RESET pin
41	P0_18 TRCDAT0	Digital I/O	nRF52 general purpose I/O pin Trace port output
42	P0_16 TRCDAT1	Digital I/O	nRF52 general purpose I/O pin Trace port output
43	P0_15 TRCDAT2	Digital I/O	nRF52 general purpose I/O pin Trace port output
44	P0_14 TRCDAT3	Digital I/O	nRF52 general purpose I/O pin Trace port output
45 .. 73	NC	Not Connected	Isolated pad on application PCB for mechanical stability
74	GND	Ground	Segmented Ground Plane Must be connected to ground on application PCB

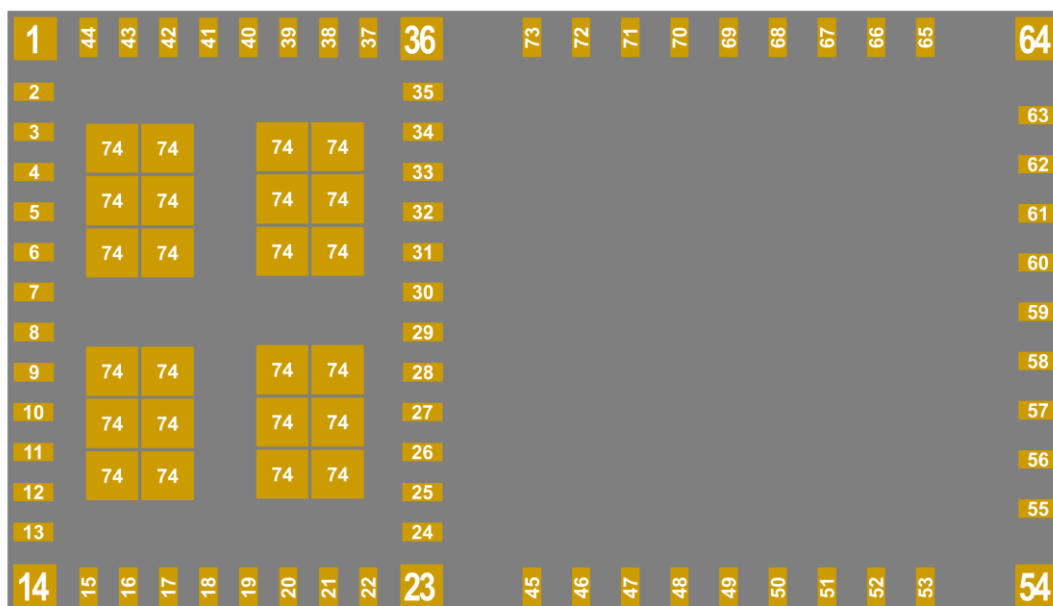

ISP4520 pad placement and pin assignment for the LGA QFN package

TOP VIEW

4. Mechanical Outlines

4.1. Mechanical Dimensions

Dimensional drawing for 9.8 x 17.2 x 1.7 mm, 74-Pad LGA Package

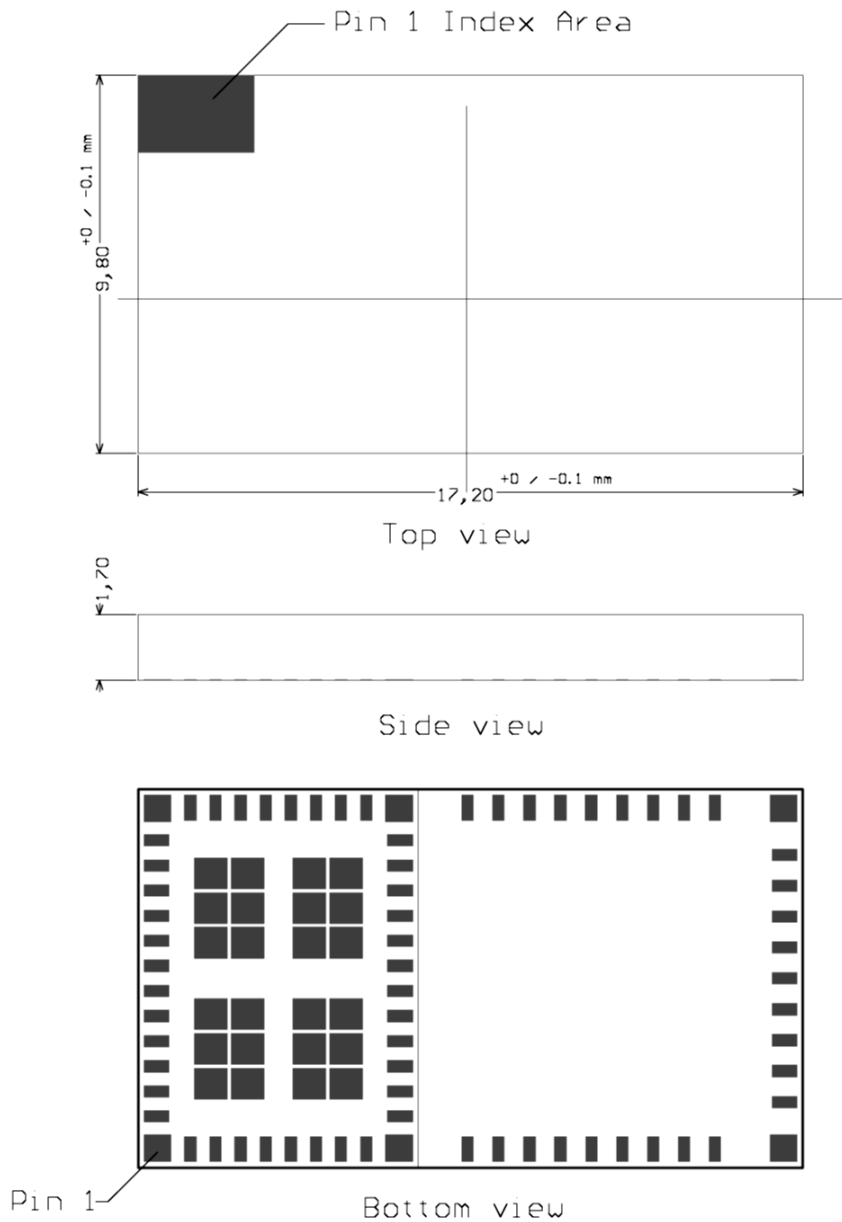

UNIT: mm TOLERANCE: +/- 0.05 mm except notified



Detail of LGA package pad positioning and size

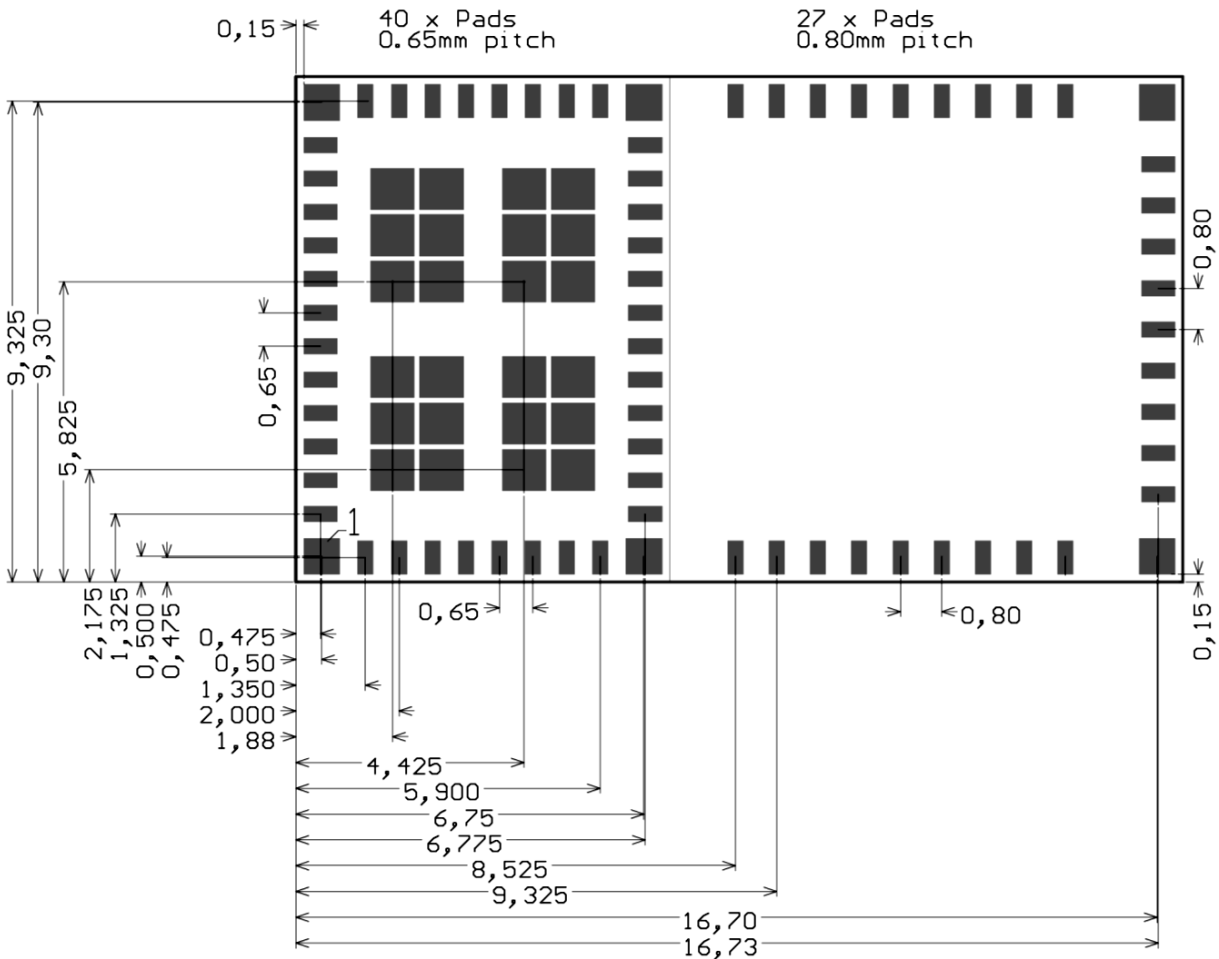

Bottom view

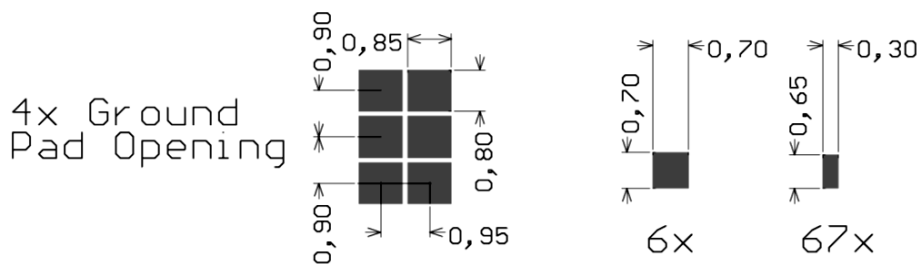

4.2. SMT Assembly Guidelines

For PCB Land Patterns and Solder Mask layout, Insight SiP recommends the use of the same dimensions as the module pads, i.e. 0.65 x 0.30 mm for standard pads, 0.70 x 0.70 mm for corner pads, 2.75 x 2.15 mm for mechanical pads.

Please contact Insight SiP for more detailed information.

4.3. Antenna Keep-Out Zone

For optimal antenna performance, it is recommended to respect a metal exclusion zone to the edge of the board: no metal, no traces and no components on any application PCB layer except mechanical LGA pads.

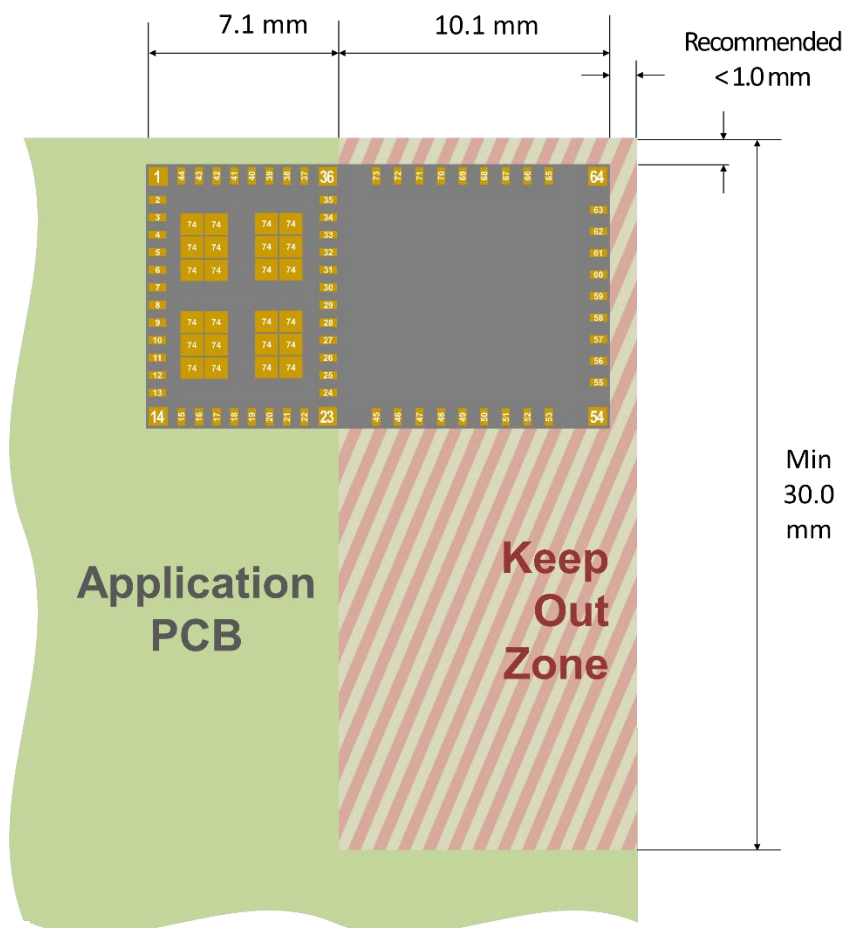

5. Product Development Tools

5.1. Hardware

In order to assist clients in developing their solutions based on the ISP4520, Insight SiP offers an Evaluation Board containing:

- One Interface Board with J-Link Seeger integrated SWD/JTAG interface
- One Test Board
- One Rx Gateway Board
- Cables

Using this evaluation board, product developers can use a working solution as starting point to develop their own products. Time to market is saved by avoiding starting from a blank sheet of paper.

Please refer to the documentation for more information:

https://www.insightsip.com/fichiers_insightsip/pdf/ble/ISP4520/isp_lora_DS4520_DK.pdf

5.2. Firmware

ISP4520 supports Bluetooth Low Energy protocol stacks, ANT protocol stacks as well as 2.4 GHz protocol stacks, including Gazell. For more details regarding SoftDevice stacks and their compatibility with ISP4520 module version, please refer to the Nordic info center at <https://infocenter.nordicsemi.com>. All stacks can be downloaded at www.nordicsemi.com.

- + The S132 SoftDevice is a Bluetooth low energy Central and Peripheral protocol stack solution. It supports up to twenty connections with an additional observer and a broadcaster role all running concurrently. The S132 SoftDevice integrates a Bluetooth low energy Controller and Host and provides a full and flexible API for building Bluetooth low energy ISP1507 solutions.
- + The S212 SoftDevice is an ANT protocol stack solution that provides a full and flexible Application Programming Interface (API) for building ANT System on ISP1507 solutions. The S212 SoftDevice simplifies combining the ANT protocol stack and an application on the same CPU.
- + The S332 SoftDevice is a combined ANT™ and Bluetooth low energy (BLE) protocol stack solution. It supports all four Bluetooth low energy roles (Central, Peripheral, Observer, Broadcaster) and ANT.

ISP4520 supports LoRa protocol. Stack and examples for P2P and LoRaWan are available to download on the product page:

https://www.insightsip.com/fichiers_insightsip/pdf/ble/ISP4520/ISP4520_Source_Code.zip

Please refer to the documentation for more information:

https://www.insightsip.com/fichiers_insightsip/pdf/ble/ISP4520/isp_lora_AN190301.pdf

5.3. Development Tools

The following development tools and software are recommended for using and testing the ISP4520 module:

- + Nordic Semiconductor nRFgo Studio or nRF Connect for Desktop:
Downloadable after registering at www.nordicsemi.com.
- + Debugging and IDE:
SEGGER Embedded Studio (SES):
Downloadable from <https://www.segger.com/products/development-tools/embedded-studio/>

Keil MDK-ARM Lite (limited to 32 KB code)
Downloadable from <https://www.keil.com/demo/eval/arm.htm>.
- + Segger J-Link Lite:
Downloadable from <http://www.segger.com/jlink-software.html>.
- + nRF52 Software Development Kit (SDK):
nRF5-SDK can be downloaded at www.nordicsemi.com. It contains example of source codes applications (C language):
 - Precompiled HEX files
 - Source code
 - SES project files
 - Keil ARM project files
 - IAR project files
- + LoRa Software Development Kit (SDK):
SDK can be downloaded at <https://www.insightsip.com/products/combo-smart-modules/isp4520>. It contains example of source codes applications (C language):
 - Precompiled HEX files
 - Source code
 - SES project files

5.4. LoRa Rx/Tx Switch Control

A LoRa RX/TX switch is integrated in the ISP4520. The state of this switch is controlled by the DIO2 pin of the SX126x. The SX126x driver provides a function called `SX126xSetDio2AsRfSwitchCtrl()` that allows to do it automatically.

The power of the switch is supplied by the DIO3 pin of the SX126x. This allows to power down the switch when it is not needed and therefore save power. However there is no function to do it automatically in the SX126x driver. The user needs to implement a specific set of instruction to control the state of the DIO3.



To configure DIO3 as output, the following SX126x register need to be modified:

- + Set bit 3 of register @0x0580 to 1
- + Set bit 3 of register @0x0583 to 0
- + Set bit 3 of register @0x0584 to 0
- + Set bit 3 of register @0x0585 to 0
- + Set bits [0 to 2] of register @0x0920 to 0x06

These configuration steps have to be repeated each time the SX126x exits SLEEP mode. DIO3 then needs to be set high before any LoRA activity and set low after:

- + Set bit 3 of register @0x0920 to 1 (high state) or 0 (low state)

An example of implementation of this control is provided in our LoRa SDK in the SX126x driver specific target board functions implementation file (sx126x-board.c). Please download from:
https://www.insightsip.com/fichiers_insightsip/pdf/ble/ISP4520/ISP4520_Source_Code.zip

6. Reference Design

6.1. Sensor Board Design

The ISP4580 is an autonomous low-power device for wireless acceleration, temperature, light and barometer detection. The complete device makes use of Insight SiP ISP4520 module together with low power Accelerometer/Magneto, Humidity/Temperature and Barometer sensors connected to a primary button cell battery CR2032.

The ST Micro LSM9DS1 is a 3D accelerometer, 3D magnetometer and 3D gyroscope used to detect acceleration and is combined with Sensirion SHTC3 temperature / humidity, a ST Micro LPS22HB barometer sensor and a Maxim MAX44009 ambient light sensor. 3 mini-LED are also part of the board and is available to be controlled by software. Sensor data are transmitted via I2C to the processor.

ISP4520 Connections

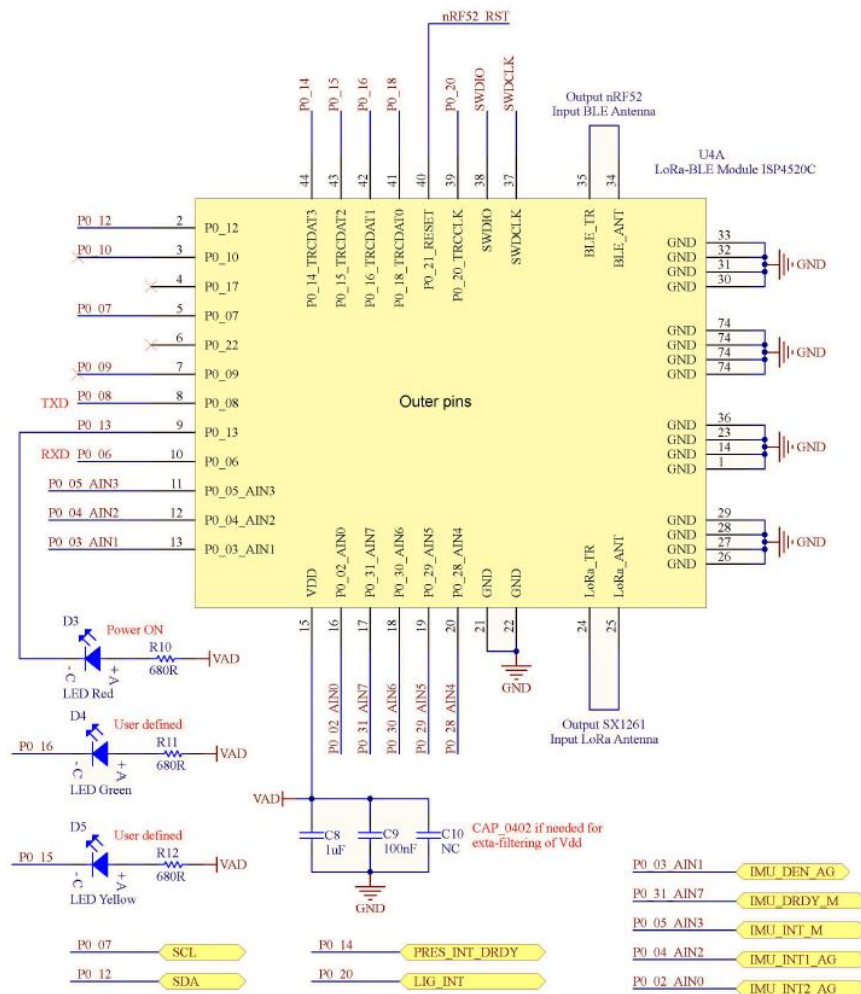

Sensor connections

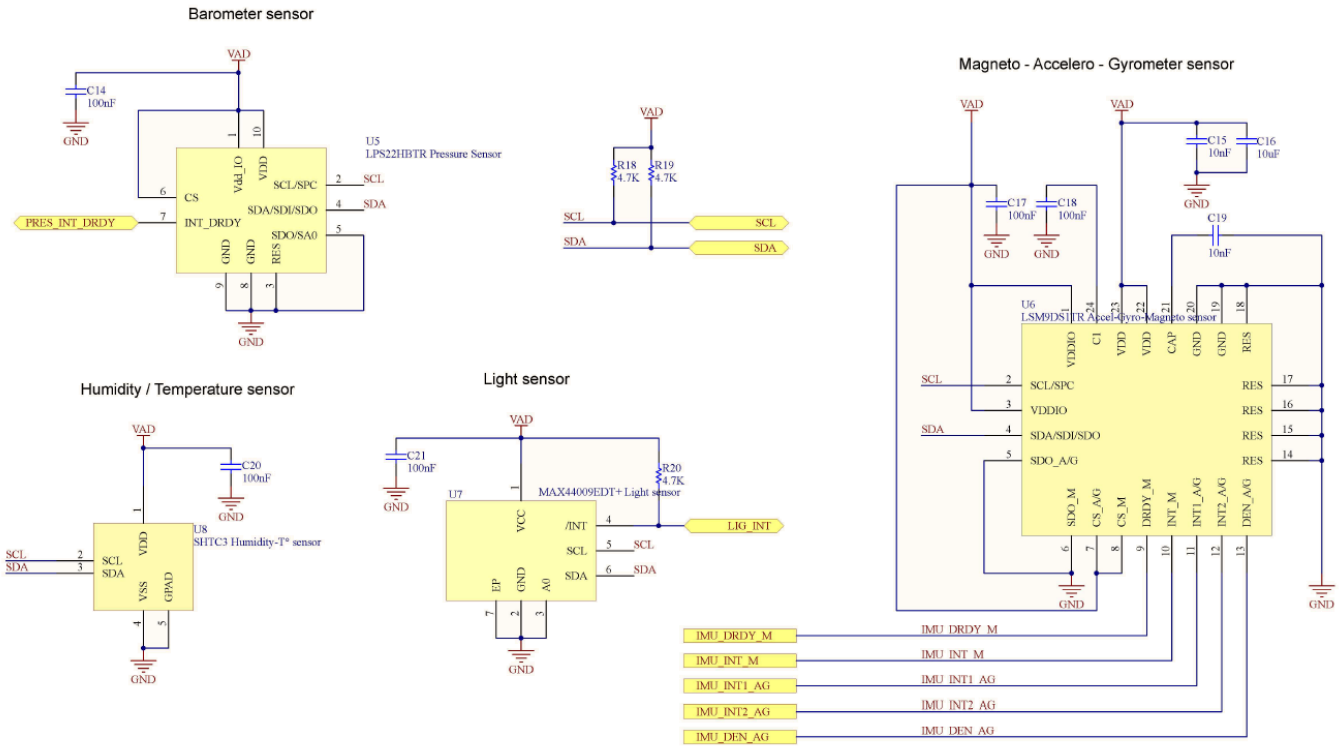

USB Connections

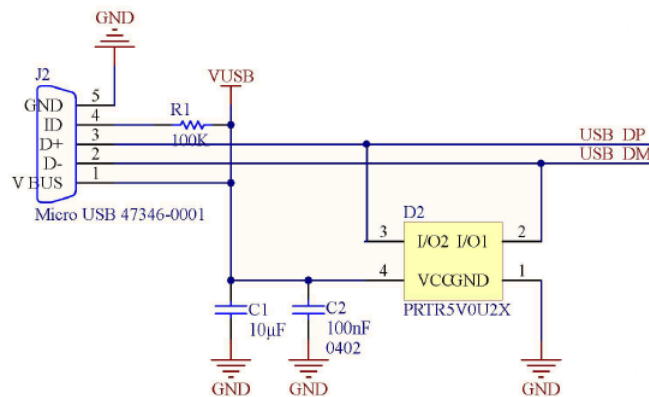

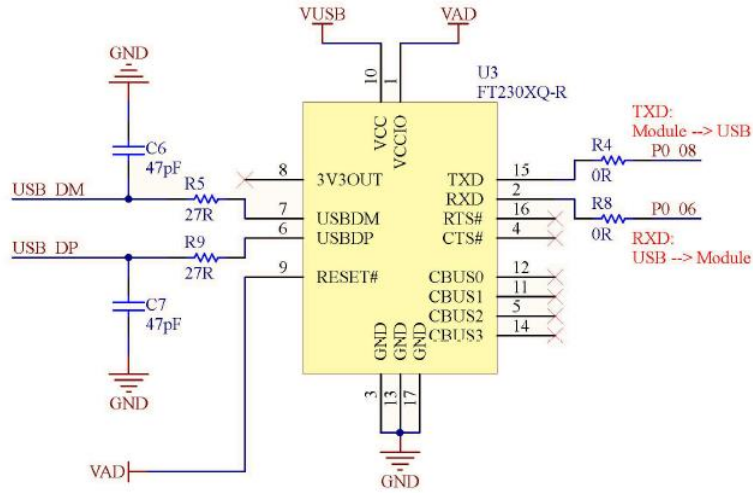

Power Supply

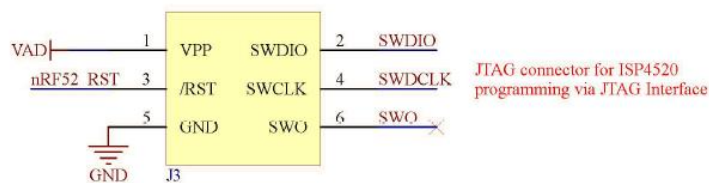
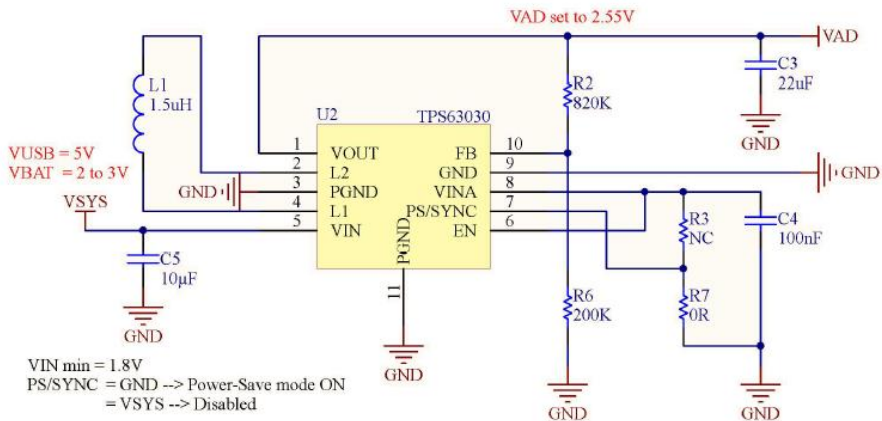
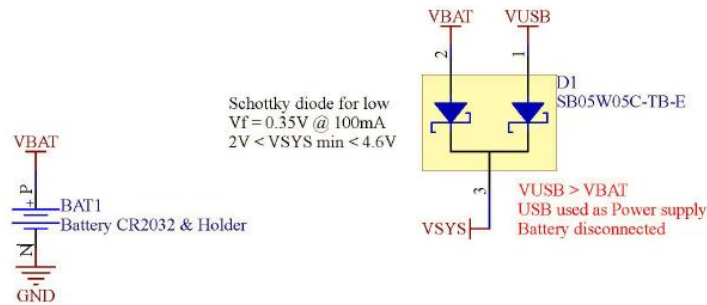

7. Packaging & Ordering information

7.1. Marking

M	/N	:	I	S	P	4	5	2	0
T	T		Y	Y	W	W	R		

ISP4520	Part Number
TT	2 letters Module Type (see section 7.5)
YY	2 digits year number
WW	2 digits week number
R	1 letter Hardware revision



7.2. Prototype Packaging

For engineering samples and prototype quantities up to 99 units, deliveries are provided in thermoformed trays. Please order with “ST” code packaging suffix.

They are delivered in sealed pack with desiccant pack and humidity sensors. Please see section 8.2 for more information on moisture sensitivity.

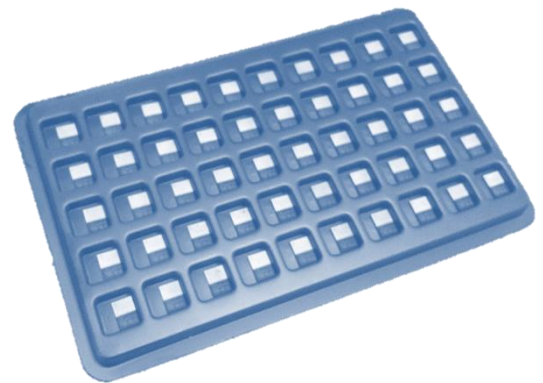

7.3. Jedec Trays

For higher quantities and volume production, ISP4520 are available in Jedec trays. They are delivered in sealed pack with desiccant pack and humidity sensors. These Jedec trays are also suitable for further baking. Please see section 8.2 for more information on moisture sensitivity.

Jedec trays are proposed in standard quantities of 100 units, 200 units and multiples of 200 units only. Please order with “J1” code packaging suffix for 100-unit tray and “J2” for 200 and multiple unit trays.

Complete information on Jedec trays is available on request.

7.4. Tape and Reel

ISP4520 are also available in Tape & Reel. They are delivered in sealed pack with desiccant pack and humidity sensors. Reels are proposed in standard quantities of 500 units (180mm / 7" reel) or 2000 units (330mm / 13" reel) only. Please order with "RS" code packaging suffix for 500-unit reels and "R2" for 2000-unit reels.

Complete information is available on request.

7.5. Ordering Information

I	S	P	4	5	2	0	-	T	T	-	Z	Z	
								▼	▼		▼	▼	
								▼	▼		▼	▼	
								▼	▼		▼	▼	
I	S	P	4	5	2	0							Part Number
							-	E	U				LoRa EU frequency range & BLE protocol (1)
							-	U	S				LoRa US frequency range & BLE protocol (1)
							-	A	S				LoRa AS frequency range & BLE protocol (1)
													Unsealed Tray Packaging
							-	S	T				Jedec Tray
							-	J	T				Reel of 500 units
							-	R	S				Reel of 2000 units
							-	R	2				

(1) Refer to section 2.6 for frequency bands

8. Storage & Soldering information

8.1. Storage and Handling

- ✚ Keep this product away from other high frequency devices which may interfere with operation such as other transmitters and devices generating high frequencies.
- ✚ Do not expose the module to the following conditions:
 - Corrosive gasses such as Cl₂, H₂S, NH₃, SO₂, or NO_X
 - Extreme humidity or salty air
 - Prolonged exposure to direct Sunlight
 - Temperatures beyond those specified for storage
- ✚ Do not apply mechanical stress
- ✚ Do not drop or shock the module
- ✚ Avoid static electricity, ESD and high voltage as these may damage the module

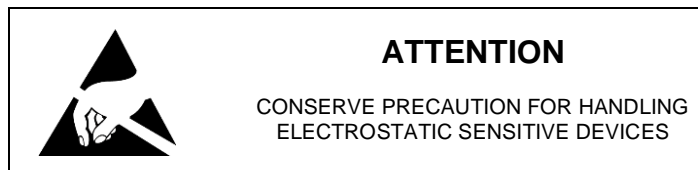

8.2. Moisture Sensitivity

All plastic packages absorb moisture. During typical solder reflow operations when SMDs are mounted onto a PCB, the entire PCB and device population are exposed to a rapid change in ambient temperature. Any absorbed moisture is quickly turned into superheated steam. This sudden change in vapor pressure can cause the package to swell. If the pressure exerted exceeds the flexural strength of the plastic mold compound, then it is possible to crack the package. Even if the package does not crack, interfacial delamination can occur.

Since the device package is sensitive to moisture absorption, it is recommended to bake the product before assembly. The baking process for dry packing is 24 hours at 125°C.

ISP4520 has been tested MSL-5 according to standards. After baking, modules can be exposed to ambient room conditions (approximately 30 °C/60%RH) during 48 hours before assembly on the PCB.



8.3. Soldering information

Recommendation for RoHS reflow process is according to Jedec J-STD-020 and 033 standard profiles.

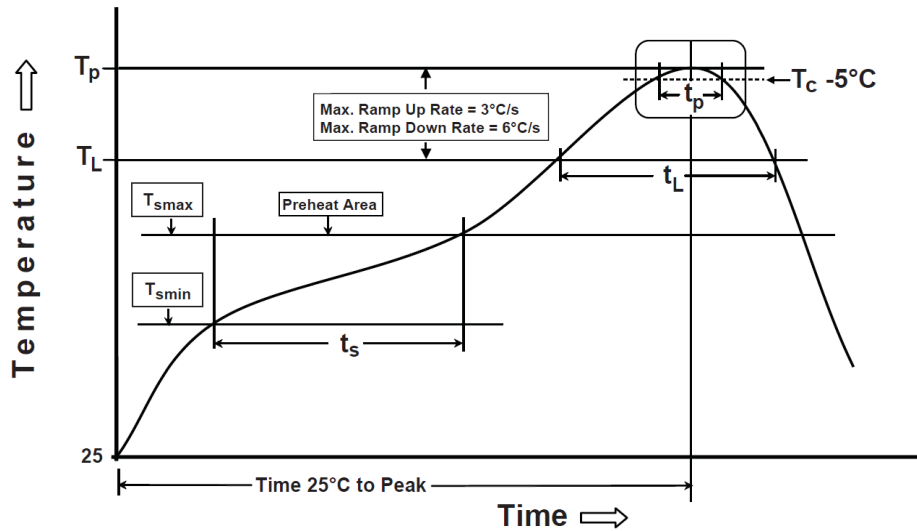

Preheat/Soak	
Temperature Min (T_{smin})	150 °C
Temperature Max (T_{smax})	200 °C
Time (t_s) from (T_{smin} to T_{smax})	60-120 sec
Ramp-up rate (T_L to T_p)	3 °C/sec max
Liquidous temperature (T_L)	217 °C
Time (t_L) maintained above T_L	60-150 sec

Peak package body temperature (T_p)	260°C (+0/-5°C)
Classification Temperature (T_c)	260 °C
Time (t_p) maintained above T_c-5 °C	30 sec
Ramp-down rate (T_p to T_L)	6 °C/sec max
Time 25 °C to peak temperature	8 mn max

9. Quality & User information

9.1. Pending Certifications

- ✚ FCC Identifier tbd
- ✚ CE: Complies with 1999/5/EC, EN300328 V1.9.1 – EC DoC N° tbd
- ✚ Bluetooth SIG certified N° tbd
- ✚ RoHS compliant

9.2. USA – User information

This intends to inform how to specify the FCC ID of our module “ISP4520” on the product. Based on the Public Notice from FCC, the host device should have a label which indicates that it contains our module. The label should use wording such as:

“Contains FCC ID: 2AAQS-ISP4520”

Any similar wording that expresses the same meaning may be used.

The label of the host device should also include the below FCC Statement. When it is not possible, this information should be included in the User Manual of the host device:

*“This device complies with part 15 of the FCC rules. Operation is subject to the following two conditions.
(1) This device may not cause harmful interference
(2) This device must accept any interference received, including interference that may cause undesired operation.
Caution: Any Changes or modifications not expressly approved by the party responsible for compliance could void the user’s authority to operate the equipment.”*

9.3. Canada – User information

This intends to inform how to specify the IC ID of our module “ISP4520” on the product. According to Canadian standards “RSS-210” and “RSS-Gen”, the host device should have a label which indicates that it contains our module. The label should use wording such as:

“Contains IC: 11306A-ISP4520”

Any similar wording that expresses the same meaning may be used.

The label of the host device should also include the below IC Statement. When it is not possible, this information should be included in the User Manual of the host device:

“This device complies with Industry Canada licence-exempt RSS standard(s). Operation is subject to the following two conditions: (1) this device may not cause interference, and (2) this device must accept any interference, including interference that may cause undesired operation of the device.

Le présent appareil est conforme aux CNR d'Industrie Canada applicables aux appareils radio exempts de licence. L'exploitation est autorisée aux deux conditions suivantes : (1) l'appareil ne doit pas produire de brouillage, et (2) l'utilisateur de l'appareil doit accepter tout brouillage radioélectrique subi, même si le brouillage est susceptible d'en compromettre le fonctionnement.”

9.4. RF Exposure Information

This equipment complies with FCC/IC radiation exposure limits set forth for an uncontrolled environment and meets the FCC radio frequency (RF) Exposure Guidelines in Supplement C to OET65 and RSS-102 of the IC radio frequency (RF) Exposure rules. This equipment has very low levels of RF energy that it deemed to comply without maximum permissive exposure evaluation (MPE).

9.5. Informations concernant l'exposition aux fréquences radio (RF)

La puissance de sortie émise par l'appareil de sans fil est inférieure à la limite d'exposition aux fréquences radio d'Industry Canada (IC). Ce module a également été évalué et démontré conforme aux limites d'exposition aux RF d'IC dans des conditions d'exposition à des appareils mobiles et/ou portables.

9.6. Discontinuity

Normally a product will continue to be manufactured as long as all of the following are true:

- The manufacturing method is still available.
- There are no replacement products.
- There is demand for it in the market.

In case of obsolescence, Insight SiP will follow Jedec Standard JSD-48. A Product Discontinuation Notice (PDN) will be sent to all distributors and made available on our website. After this, the procedure goes as follows:

- Last Order Date will be 6 months after the PDN was published.
- Last Shipment Date will be 6 months after Last Order Date, i.e. 12 months after PDN.

9.7. Disclaimer

Insight SiP's products are designed and manufactured for general consumer applications, so testing and use of the product shall be conducted at customer's own risk and responsibility. Please conduct validation and verification and sufficient reliability evaluation of the products in actual condition of mounting and operating environment before commercial shipment of the equipment. Please also pay attention (i) to apply soldering method that don't deteriorate reliability, (ii) to minimize any mechanical vibration, shock, exposure to any static electricity, (iii) not to overstress the product during and after the soldering process.

The products are not designed for use in any application which requires especially high reliability where malfunction of these products can reasonably be expected to result in personal injury or damage to the third party's life, body or property, including and not limited to (i) aircraft equipment, (ii) aerospace equipment, (iii) undersea equipment, (iv) power plant control equipment, (v) medical equipment, (vi) transportation equipment, (vii) traffic signal equipment, (viii) disaster prevention / crime prevention equipment.

The only warranty that Insight SiP provides regarding the products is its conformance to specifications provided in datasheets. Insight SiP hereby disclaims all other warranties regarding the products, express or implied, including without limitation any warranty of fitness for a particular purpose, that they are defect-free, or against infringement of intellectual property rights. Insight SiP customers agree to indemnify and defend Insight SiP against all claims, damages, costs and expenses that may be incurred, including without any limitation, attorney fees and costs, due to the use of products.



Компания «ЭлектроПласт» предлагает заключение долгосрочных отношений при поставках импортных электронных компонентов на взаимовыгодных условиях!

Наши преимущества:

- Оперативные поставки широкого спектра электронных компонентов отечественного и импортного производства напрямую от производителей и с крупнейших мировых складов;
- Поставка более 17-ти миллионов наименований электронных компонентов;
- Поставка сложных, дефицитных, либо снятых с производства позиций;
- Оперативные сроки поставки под заказ (от 5 рабочих дней);
- Экспресс доставка в любую точку России;
- Техническая поддержка проекта, помощь в подборе аналогов, поставка прототипов;
- Система менеджмента качества сертифицирована по Международному стандарту ISO 9001;
- Лицензия ФСБ на осуществление работ с использованием сведений, составляющих государственную тайну;
- Поставка специализированных компонентов (Xilinx, Altera, Analog Devices, Intersil, Interpoint, Microsemi, Aeroflex, Peregrine, Syfer, Eurofarad, Texas Instrument, Miteq, Cobham, E2V, MA-COM, Hittite, Mini-Circuits, General Dynamics и др.);

Помимо этого, одним из направлений компании «ЭлектроПласт» является направление «Источники питания». Мы предлагаем Вам помощь Конструкторского отдела:

- Подбор оптимального решения, техническое обоснование при выборе компонента;
- Подбор аналогов;
- Консультации по применению компонента;
- Поставка образцов и прототипов;
- Техническая поддержка проекта;
- Защита от снятия компонента с производства.



Как с нами связаться

Телефон: 8 (812) 309 58 32 (многоканальный)

Факс: 8 (812) 320-02-42

Электронная почта: org@eplast1.ru

Адрес: 198099, г. Санкт-Петербург, ул. Калинина, дом 2, корпус 4, литера А.