

# RF LDMOS Wideband Integrated Power Amplifiers

The MW7IC2240N wideband integrated circuit is designed with on-chip matching that makes it usable from 2000 to 2200 MHz. This multi-stage structure is rated for 24 to 32 Volt operation and covers all typical cellular base station modulation formats including TD-SCDMA.

## Typical Performance

- Typical Single-Carrier W-CDMA Performance:  $V_{DD} = 28$  Volts,  $I_{DQ1} = 90$  mA,  $I_{DQ2} = 420$  mA,  $P_{out} = 4$  Watts Avg.,  $f = 2112.5$  MHz, IQ Magnitude Clipping, Channel Bandwidth = 3.84 MHz. PAR = 7.5 dB @ 0.01% Probability on CCDF.  
Power Gain — 30 dB  
Power Added Efficiency — 14%  
ACPR @ 5 MHz Offset — -50 dBc in 3.84 MHz Bandwidth
- Capable of Handling 5:1 VSWR, @ 28 Vdc, 2140 MHz, 40 Watts CW Output Power
- $P_{out}$  @ 1 dB Compression Point  $\approx$  40 Watts CW
- Stable into a 5:1 VSWR. All Spurs Below -60 dBc @ 100 mW to 10 Watts CW  $P_{out}$ .

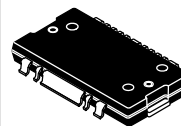
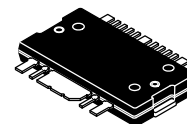
## Features

- Characterized with Series Equivalent Large-Signal Impedance Parameters and Common Source Scattering Parameters
- On-Chip Matching (50 Ohm Input, DC Blocked, >3 Ohm Output)
- Integrated Quiescent Current Temperature Compensation with Enable/Disable Function (1)
- Integrated ESD Protection
- 225°C Capable Plastic Package
- RoHS Compliant
- In Tape and Reel. R1 Suffix = 500 Units, 44 mm Tape Width, 13 inch Reel.

**MW7IC2240NR1**  
**MW7IC2240GNR1**  
**MW7IC2240NBR1**

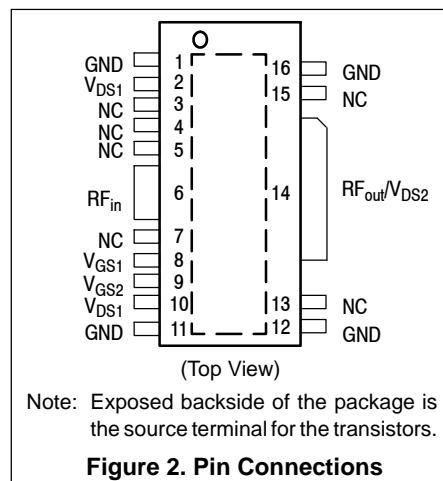
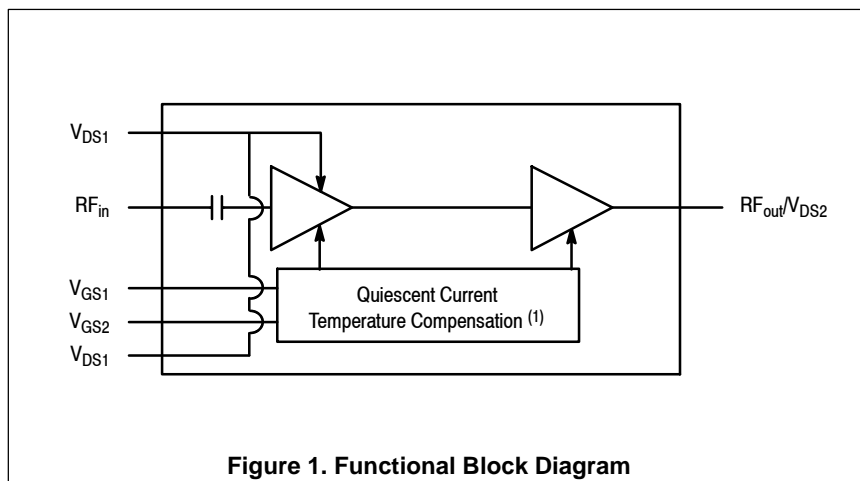
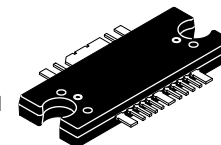
**2110-2170 MHz, 4 W Avg., 28 V**  
**SINGLE W-CDMA**  
**RF LDMOS WIDEBAND**  
**INTEGRATED POWER AMPLIFIERS**

**CASE 1886-01**  
**TO-270 WB-16**  
**PLASTIC**  
**MW7IC2240NR1**



**CASE 1887-01**  
**TO-270 WB-16 GULL**  
**PLASTIC**  
**MW7IC2240GNR1**

**CASE 1329-09**  
**TO-272 WB-16**  
**PLASTIC**  
**MW7IC2240NBR1**



1. Refer to AN1977, *Quiescent Current Thermal Tracking Circuit in the RF Integrated Circuit Family* and to AN1987, *Quiescent Current Control for the RF Integrated Circuit Device Family*. Go to <http://www.freescale.com/rf>. Select Documentation/Application Notes - AN1977 or AN1987.

**Table 1. Maximum Ratings**

Rating	Symbol	Value	Unit
Drain-Source Voltage	$V_{DSS}$	-0.5, +65	Vdc
Gate-Source Voltage	$V_{GS}$	-0.5, +5	Vdc
Operating Voltage	$V_{DD}$	32, +0	Vdc
Storage Temperature Range	$T_{stg}$	-65 to +150	°C
Case Operating Temperature	$T_C$	150	°C
Operating Junction Temperature <sup>(1,2)</sup>	$T_J$	225	°C
Input Power	$P_{in}$	20	dBm

**Table 2. Thermal Characteristics**

Characteristic	Symbol	Value <sup>(2,3)</sup>	Unit
Thermal Resistance, Junction to Case	$R_{\theta JC}$		°C/W
4 W CW ( $P_{out} = 3.95$ W CW, Case Temperature = 68°C)		3.9	
Stage 1, 28 Vdc, $I_{DQ1} = 90$ mA Stage 2, 28 Vdc, $I_{DQ2} = 420$ mA		1.3	
40 W CW ( $P_{out} = 39.4$ W CW, Case Temperature = 80°C)		3.2	
Stage 1, 28 Vdc, $I_{DQ1} = 90$ mA Stage 2, 28 Vdc, $I_{DQ2} = 420$ mA		1.2	

**Table 3. ESD Protection Characteristics**

Test Methodology	Class
Human Body Model (per JESD22-A114)	0 (Minimum)
Machine Model (per EIA/JESD22-A115)	A (Minimum)
Charge Device Model (per JESD22-C101)	II (Minimum)

1. Continuous use at maximum temperature will affect MTTF.
2. MTTF calculator available at <http://www.freescale.com/rf>. Select Software & Tools/Development Tools/Calculators to access MTTF calculators by product.
3. Refer to AN1955, *Thermal Measurement Methodology of RF Power Amplifiers*. Go to <http://www.freescale.com/rf>. Select Documentation/Application Notes - AN1955.

(continued)

**Table 4. Moisture Sensitivity Level**

Test Methodology	Rating	Package Peak Temperature	Unit
Per JESD 22-A113, IPC/JEDEC J-STD-020	3	260	°C

**Table 5. Electrical Characteristics** ( $T_A = 25^\circ\text{C}$  unless otherwise noted)

Characteristic	Symbol	Min	Typ	Max	Unit
----------------	--------	-----	-----	-----	------

**Stage 1 — Off Characteristics**

Zero Gate Voltage Drain Leakage Current ( $V_{DS} = 65\text{ Vdc}$ , $V_{GS} = 0\text{ Vdc}$ )	$I_{DSS}$	—	—	10	$\mu\text{A dc}$
Zero Gate Voltage Drain Leakage Current ( $V_{DS} = 28\text{ Vdc}$ , $V_{GS} = 0\text{ Vdc}$ )	$I_{DSS}$	—	—	1	$\mu\text{A dc}$
Gate-Source Leakage Current ( $V_{GS} = 1.5\text{ Vdc}$ , $V_{DS} = 0\text{ Vdc}$ )	$I_{GSS}$	—	—	1	$\mu\text{A dc}$

**Stage 1 — On Characteristics**

Gate Threshold Voltage ( $V_{DS} = 10\text{ Vdc}$ , $I_D = 23\ \mu\text{A dc}$ )	$V_{GS(th)}$	1.2	2	2.7	Vdc
Gate Quiescent Voltage ( $V_{DD} = 28\text{ Vdc}$ , $I_D = 90\text{ mA dc}$ )	$V_{GS(Q)}$	—	2.9	—	Vdc
Fixture Gate Quiescent Voltage ( $V_{DD} = 28\text{ Vdc}$ , $I_D = 90\text{ mA dc}$ , Measured in Functional Test)	$V_{GG(Q)}$	9.5	13	16.5	Vdc

**Stage 1 — Dynamic Characteristics (1)**

Input Capacitance ( $V_{DS} = 28\text{ Vdc}$ , $V_{GS} = 0\text{ Vdc} \pm 30\text{ mV(rms)ac}$ @ 1 MHz)	$C_{iss}$	—	50	—	pF
--	-----------	---	----	---	----

**Stage 2 — Off Characteristics**

Zero Gate Voltage Drain Leakage Current ( $V_{DS} = 65\text{ Vdc}$ , $V_{GS} = 0\text{ Vdc}$ )	$I_{DSS}$	—	—	10	$\mu\text{A dc}$
Zero Gate Voltage Drain Leakage Current ( $V_{DS} = 28\text{ Vdc}$ , $V_{GS} = 0\text{ Vdc}$ )	$I_{DSS}$	—	—	1	$\mu\text{A dc}$
Gate-Source Leakage Current ( $V_{GS} = 1.5\text{ Vdc}$ , $V_{DS} = 0\text{ Vdc}$ )	$I_{GSS}$	—	—	1	$\mu\text{A dc}$

**Stage 2 — On Characteristics**

Gate Threshold Voltage ( $V_{DS} = 10\text{ Vdc}$ , $I_D = 150\ \mu\text{A dc}$ )	$V_{GS(th)}$	1.2	2	2.7	Vdc
Gate Quiescent Voltage ( $V_{DD} = 28\text{ Vdc}$ , $I_D = 420\text{ mA dc}$ )	$V_{GS(Q)}$	—	2.8	—	Vdc
Fixture Gate Quiescent Voltage ( $V_{DD} = 28\text{ Vdc}$ , $I_D = 420\text{ mA dc}$ , Measured in Functional Test)	$V_{GG(Q)}$	7	9.8	12.5	Vdc
Drain-Source On-Voltage ( $V_{GS} = 10\text{ Vdc}$ , $I_D = 1\text{ A dc}$ )	$V_{DS(on)}$	0.2	0.39	1.2	Vdc

**Stage 2 — Dynamic Characteristics (1)**

Reverse Transfer Capacitance ( $V_{DS} = 28\text{ Vdc} \pm 30\text{ mV(rms)ac}$ @ 1 MHz, $V_{GS} = 0\text{ Vdc}$ )	$C_{rss}$	—	0.67	—	pF
Output Capacitance ( $V_{DS} = 28\text{ Vdc} \pm 30\text{ mV(rms)ac}$ @ 1 MHz, $V_{GS} = 0\text{ Vdc}$ )	$C_{oss}$	—	205	—	pF

1. Part internally matched both on input and output.

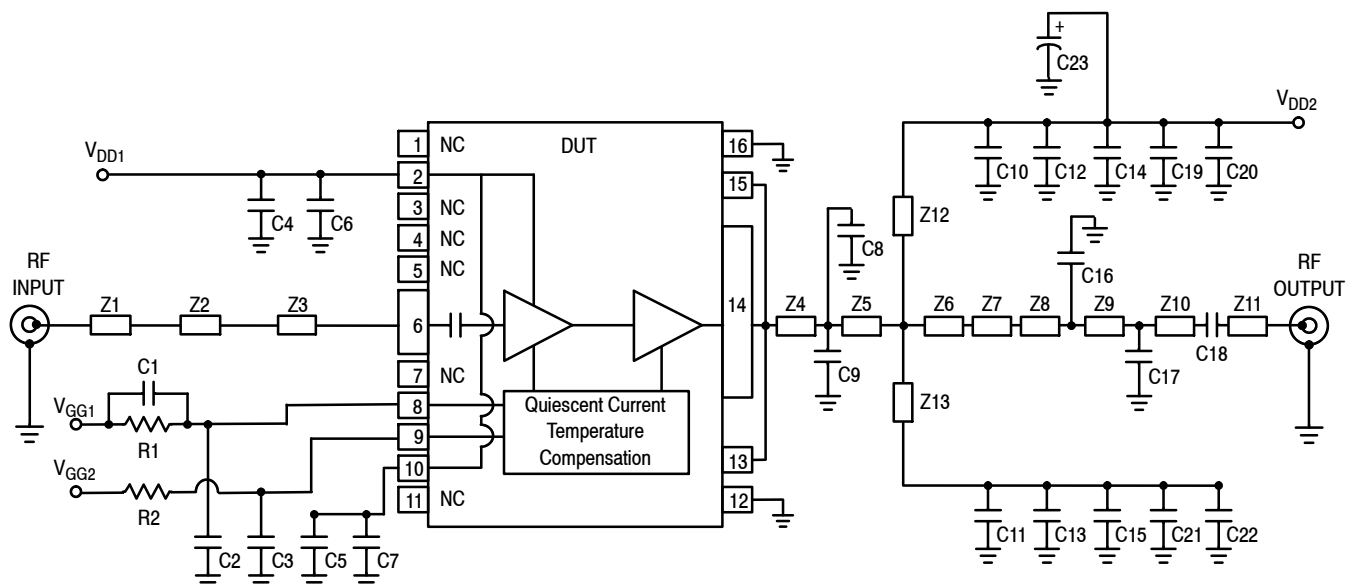
(continued)

**Table 5. Electrical Characteristics** ( $T_A = 25^\circ\text{C}$  unless otherwise noted) (continued)

Characteristic	Symbol	Min	Typ	Max	Unit
<b>Functional Tests</b> (In Freescale Wideband 2110–2170 MHz Test Fixture, 50 ohm system) $V_{DD} = 28\text{ Vdc}$ , $I_{DQ1} = 90\text{ mA}$ , $I_{DQ2} = 420\text{ mA}$ , $P_{out} = 4\text{ W Avg.}$ , $f = 2112.5\text{ MHz}$ , Single-Carrier W-CDMA, IQ Magnitude Clipping, PAR = 7.5 dB @ 0.01% Probability on CCDF. ACPR measured in 3.84 MHz Channel Bandwidth @ $\pm 5\text{ MHz}$ Offset.					
Power Gain	$G_{ps}$	28	30	33	dB
Power Added Efficiency	PAE	12	14	—	%
Adjacent Channel Power Ratio	ACPR	—	-50	-46	dBc
Input Return Loss	IRL	—	-16	-12	dB

**Typical Performances** (In Freescale Test Fixture, 50 ohm system)  $V_{DD} = 28\text{ Vdc}$ ,  $I_{DQ1} = 90\text{ mA}$ ,  $I_{DQ2} = 420\text{ mA}$ , 2110–2170 MHz

$P_{out}$ @ 1 dB Compression Point, CW	P1dB	—	40	—	W
Video Bandwidth @ 40 W PEP $P_{out}$ where $IM3 = -30\text{ dBc}$ (Tone Spacing from 100 kHz to VBW) $\Delta IMD3 = IMD3$ @ VBW frequency - $IMD3$ @ 100 kHz < 1 dBc (both sidebands)	VBW	—	10	—	MHz
Gain Flatness in 60 MHz Bandwidth @ $P_{out} = 4\text{ W Avg.}$	$G_F$	—	0.1	—	dB
Average Deviation from Linear Phase in 60 MHz Bandwidth @ $P_{out} = 40\text{ W CW}$	$\Phi$	—	1.08	—	$^\circ$
Average Group Delay @ $P_{out} = 40\text{ W CW}$ , $f = 2140\text{ MHz}$	Delay	—	1.98	—	ns
Part-to-Part Insertion Phase Variation @ $P_{out} = 40\text{ W CW}$ , $f = 2140\text{ MHz}$ , Six Sigma Window	$\Delta\Phi$	—	18.3	—	$^\circ$
Gain Variation over Temperature ( $-30^\circ\text{C}$ to $+85^\circ\text{C}$ )	$\Delta G$	—	0.05	—	dB/ $^\circ\text{C}$
Output Power Variation over Temperature ( $-30^\circ\text{C}$ to $+85^\circ\text{C}$ )	$\Delta P1dB$	—	0.004	—	dB/ $^\circ\text{C}$



Z1	2.197" x 0.083" Microstrip	Z8	0.204" x 0.083" Microstrip
Z2	0.016" x 0.083" x 0.055" Taper	Z9	0.273" x 0.083" Microstrip
Z3	0.106" x 0.055" Microstrip	Z10	0.176" x 0.083" Microstrip
Z4	0.409" x 0.322" Microstrip	Z11	0.364" x 0.083" Microstrip
Z5	0.161" x 0.322" Microstrip	Z12, Z13	0.564" x 0.083" Microstrip
Z6	0.254" x 0.322" Microstrip	PCB	Arlon Cuclad 250GX-0300-55-22, 0.030", $\epsilon_r = 2.5$
Z7	0.388" x 0.123" Microstrip		

**Figure 3. MW7IC2240NR1(GNR1)(NBR1) Test Circuit Schematic**

**Table 6. MW7IC2240NR1(GNR1)(NBR1) Test Circuit Component Designations and Values**

Part	Description	Part Number	Manufacturer
C1	8.2 pF Chip Capacitor	ATC100B8R2BT250XT	ATC
C2, C16	0.4 pF Chip Capacitors	ATC700B0R4BT500XT	ATC
C3, C14, C15	4.7 $\mu$ F, 50 V Chip Capacitors	GRM31CR71H475KA12L	Murata
C4, C5, C19, C20, C21, C22	10 $\mu$ F, 50 V Chip Capacitors	GRM55DR61H106KA88B	Murata
C6, C7, C10, C11	5.6 pF Chip Capacitors	ATC100B5R6BT250XT	ATC
C8, C9	0.3 pF Chip Capacitors	ATC700B0R3BT500XT	ATC
C12, C13	0.1 $\mu$ F Chip Capacitors	C1206C104K5RAC	Kemet
C17	0.6 pF Chip Capacitor	ATC100B0R6BT250XT	ATC
C18	6.8 pF Chip Capacitor	ATC100B6R8BT250XT	ATC
C23	470 $\mu$ F, 63 V Electrolytic Capacitor	477KXM063M	Illinois
R1, R2	10 k $\Omega$ , 1/4 W Chip Resistors	CRCW12061001FKEA	Vishay

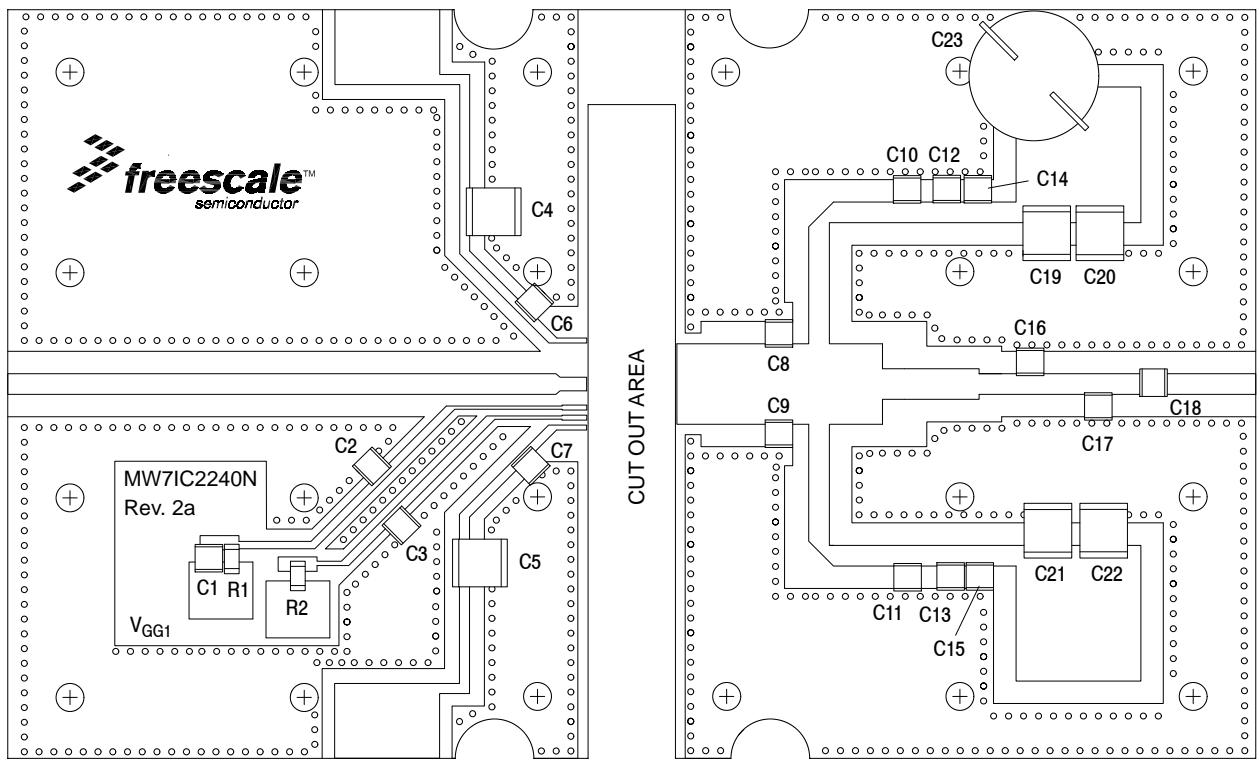
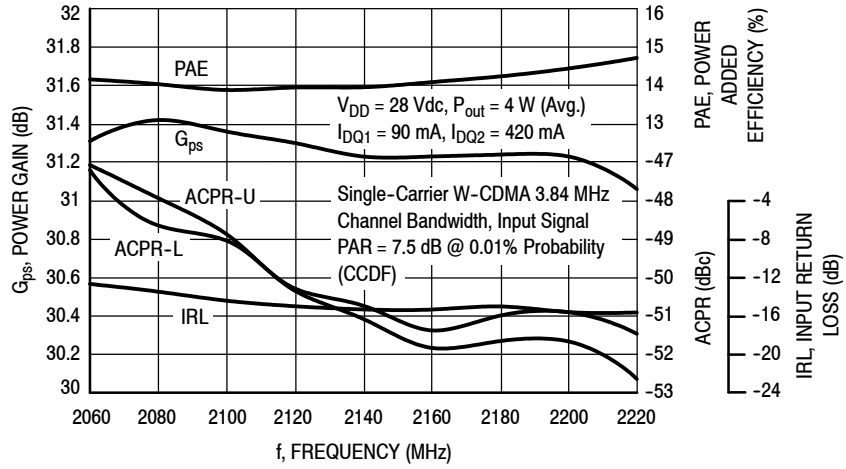
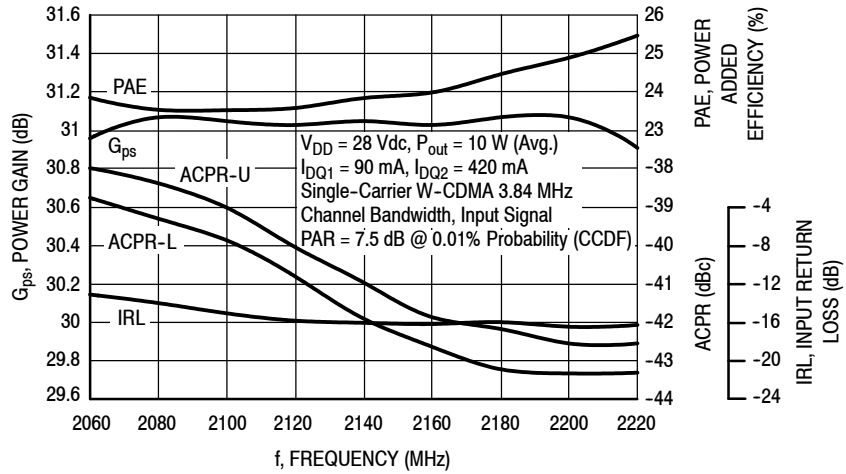


Figure 4. MW7IC2240NR1(GNR1)(NBR1) Test Circuit Component Layout

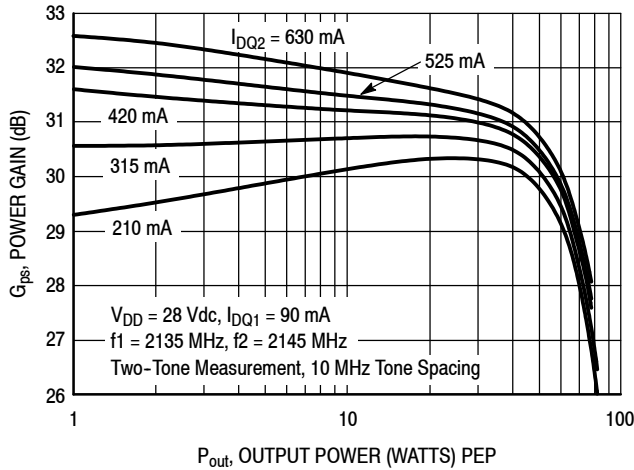
### TYPICAL CHARACTERISTICS



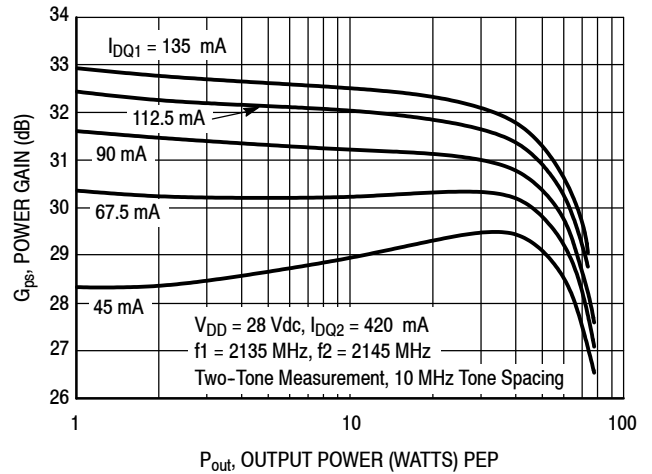
**Figure 5. Power Gain, Input Return Loss, Power Added Efficiency and ACPR versus Frequency @  $P_{out} = 4$  Watts Avg.**



**Figure 6. Power Gain, Input Return Loss, Power Added Efficiency and ACPR versus Frequency @  $P_{out} = 10$  Watts Avg.**

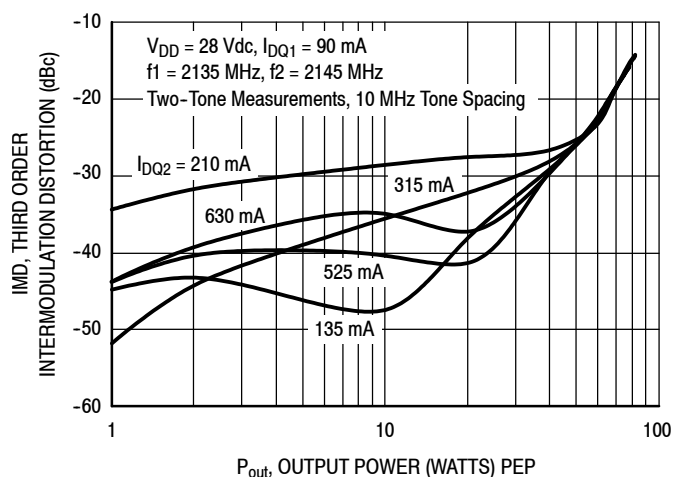


**Figure 7. Two-Tone Power Gain versus Output Power @  $I_{DQ1} = 90$  mA**

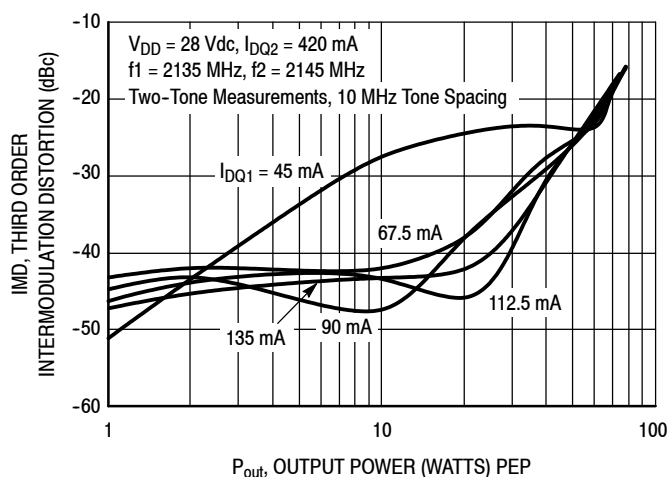


**Figure 8. Two-Tone Power Gain versus Output Power @  $I_{DQ2} = 420$  mA**

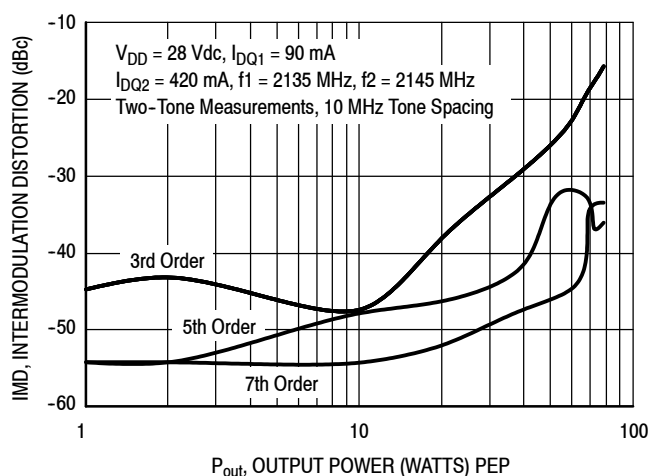
## TYPICAL CHARACTERISTICS



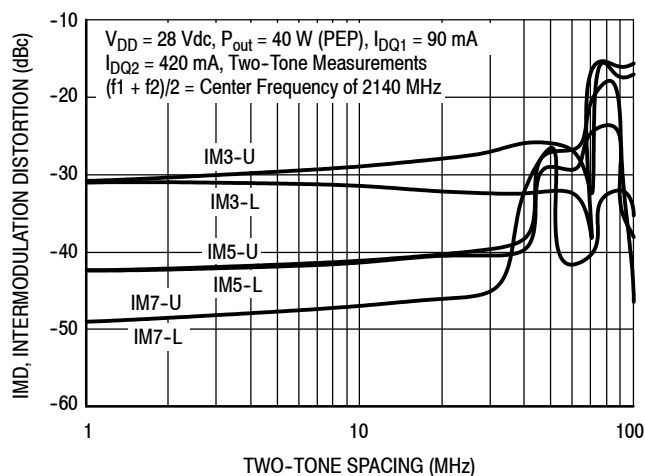
**Figure 9. Third Order Intermodulation Distortion versus Output Power @  $I_{DQ1} = 90$  mA**



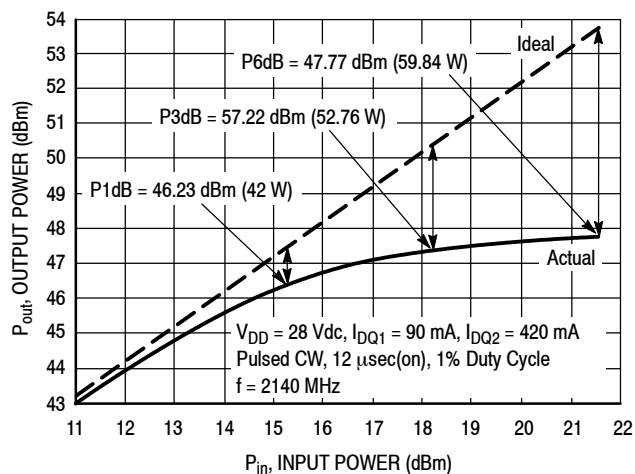
**Figure 10. Third Order Intermodulation Distortion versus Output Power @  $I_{DQ2} = 420$  mA**



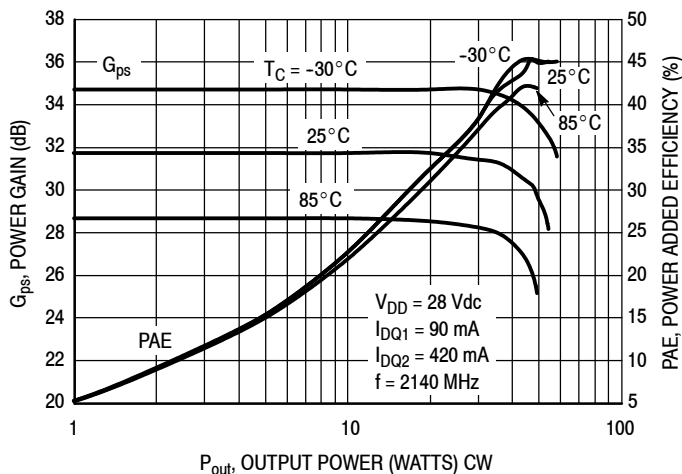
**Figure 11. Intermodulation Distortion Products versus Output Power**



**Figure 12. Intermodulation Distortion Products versus Tone Spacing**



**Figure 13. Pulsed CW Output Power versus Input Power**



**Figure 14. Power Gain and Power Added Efficiency versus CW Output Power**



## TYPICAL CHARACTERISTICS

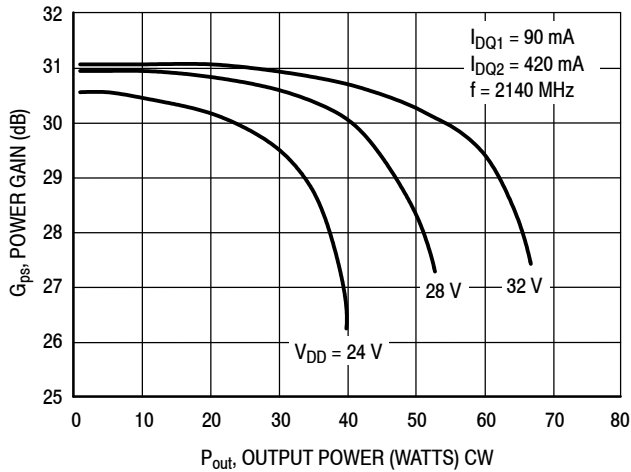


Figure 15. Power Gain versus Output Power

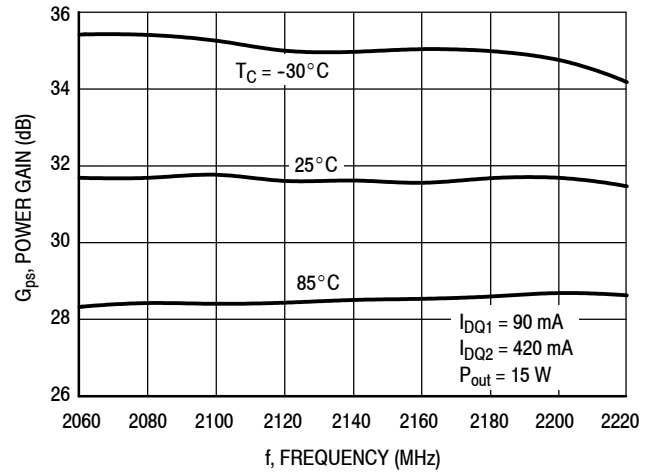


Figure 16. Power Gain versus Frequency

## W-CDMA TEST SIGNAL

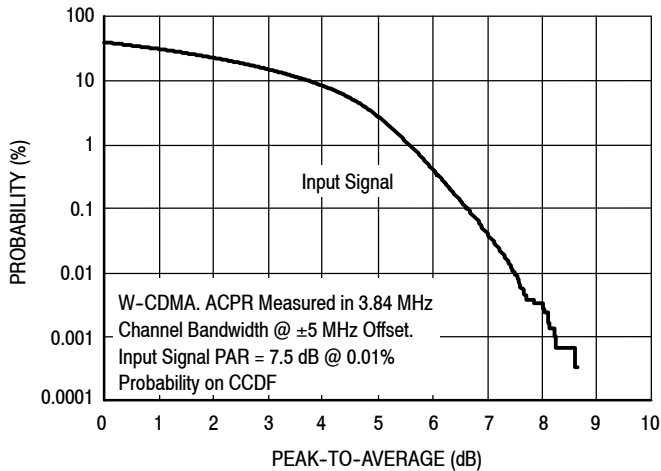


Figure 17. CCDF W-CDMA IQ Magnitude Clipping, Single-Carrier Test Signal

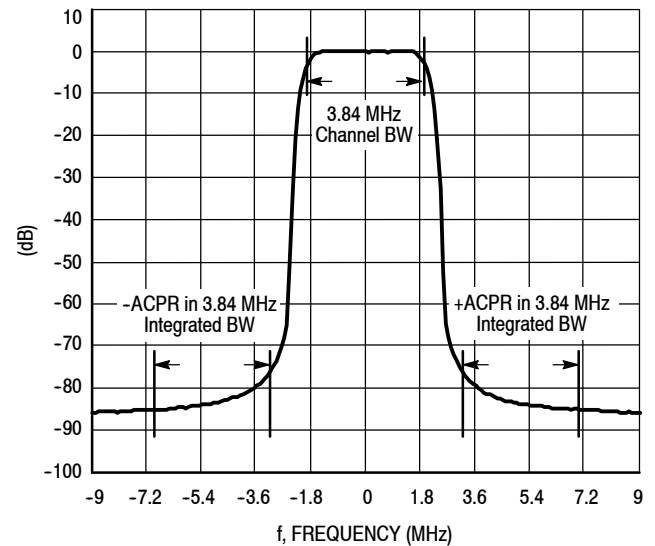
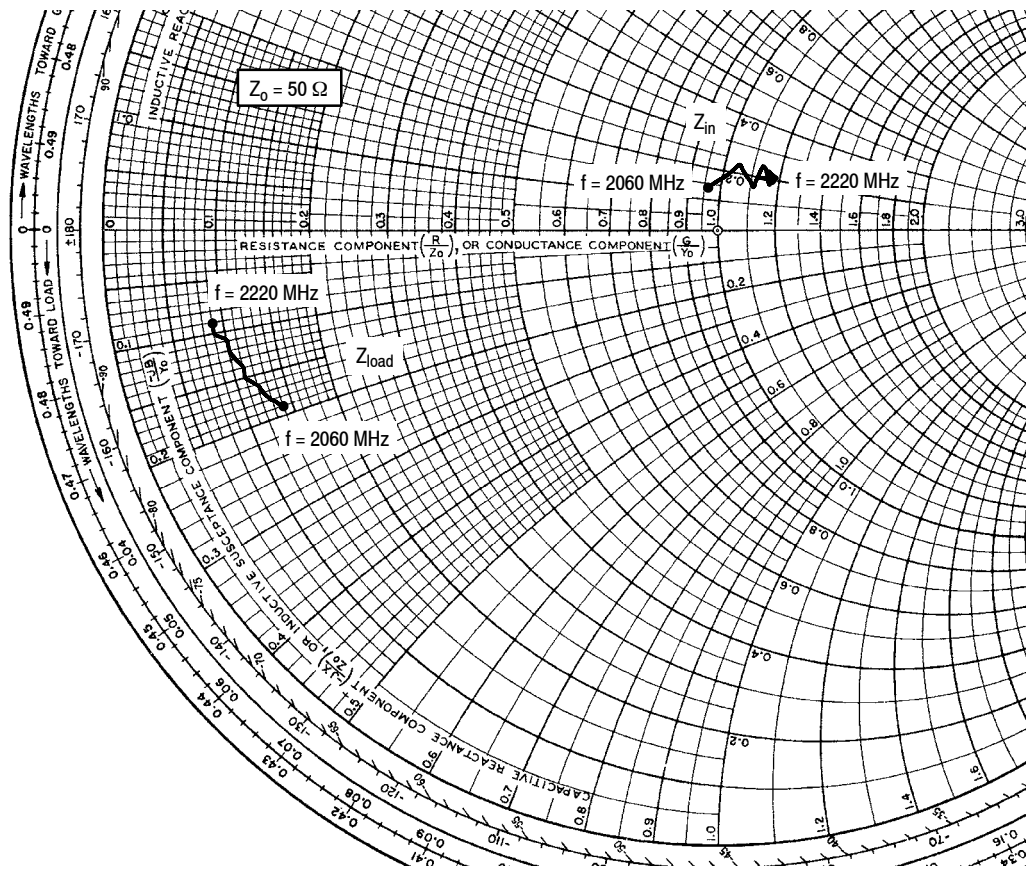


Figure 18. Single-Carrier W-CDMA Spectrum



$V_{DD} = 28 \text{ Vdc}$ ,  $I_{DQ1} = 90 \text{ mA}$ ,  $I_{DQ2} = 420 \text{ mA}$ ,  $P_{out} = 4 \text{ W Avg.}$

f MHz	$Z_{in}$ $\Omega$	$Z_{load}$ $\Omega$
2060	$48.171 + j6.940$	$6.868 - j9.687$
2080	$52.454 + j11.553$	$6.432 - j8.942$
2100	$55.468 + j8.729$	$6.051 - j8.216$
2120	$56.312 + j12.000$	$5.729 - j7.545$
2140	$58.860 + j9.463$	$5.444 - j6.869$
2160	$57.596 + j11.427$	$5.193 - j6.201$
2180	$59.603 + j10.690$	$4.958 - j5.578$
2200	$56.867 + j10.012$	$4.743 - j4.969$
2220	$58.144 + j9.805$	$4.577 - j4.353$

$Z_{in}$  = Device input impedance as measured from gate to ground.

$Z_{load}$  = Test circuit impedance as measured from drain to ground.

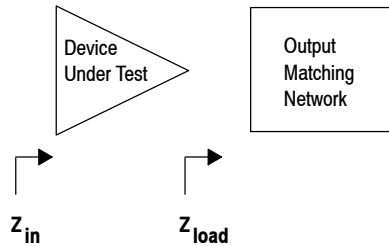


Figure 19. Series Equivalent Input and Load Impedance

**Table 7. Common Source S-Parameters** ( $V_{DD} = 28\text{ V}$ ,  $I_{DQ1} = 90\text{ mA}$ ,  $I_{DQ2} = 420\text{ mA}$ ,  $T_A = 25^\circ\text{C}$ , 50 Ohm System)

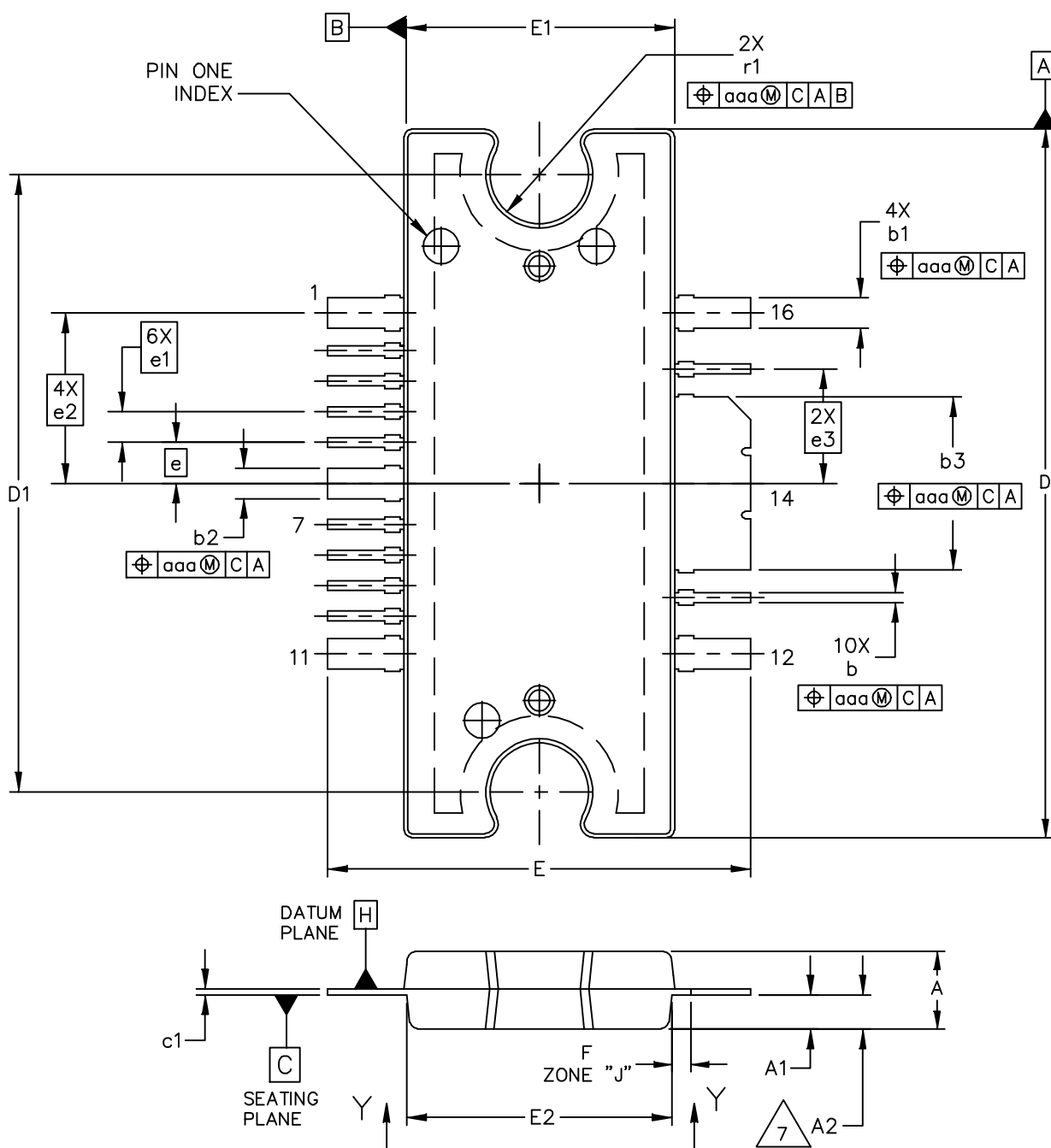
f MHz	S <sub>11</sub>		S <sub>21</sub>		S <sub>12</sub>		S <sub>22</sub>	
	S <sub>11</sub>	∠ φ	S <sub>21</sub>	∠ φ	S <sub>12</sub>	∠ φ	S <sub>22</sub>	∠ φ
1500	0.452	134	0.356	7.81	0.001	-108	0.979	160
1550	0.407	117	0.757	-7.8	0.000	-67.7	0.969	157
1600	0.354	96.5	1.430	-31	0.000	-65.8	0.955	154
1650	0.316	85.1	2.330	-52.1	0.001	-27.1	0.935	151
1700	0.279	68	3.690	-73.6	0.001	-43.4	0.909	148
1750	0.222	49.5	5.800	-93.3	0.002	-21.9	0.878	143
1800	0.140	30.4	9.570	-113	0.003	-24.8	0.833	137
1850	0.046	21.9	17.000	-137	0.004	-33.7	0.737	124
1900	0.094	135	33.600	-173	0.007	-41.8	0.476	91.7
1950	0.238	56.4	58.300	124	0.009	-86.4	0.396	-79.7
2000	0.254	-29.2	47.800	59.5	0.006	-118	0.873	-149
2050	0.241	-84.1	34.300	22.9	0.004	-122	0.927	-171
2100	0.252	-120	27.700	-3.98	0.004	-125	0.911	-179
2150	0.201	-142	23.900	-28.2	0.003	-128	0.891	177
2200	0.174	-162	21.100	-51.8	0.003	-130	0.878	175
2250	0.148	168	18.800	-75.9	0.003	-131	0.872	175
2300	0.135	103	15.800	-100	0.003	-139	0.882	175
2350	0.197	35.4	12.600	-118	0.003	-155	0.906	174
2400	0.244	1.73	11.100	-132	0.002	-156	0.919	173
2450	0.291	-11.1	10.400	-147	0.002	-157	0.926	171
2500	0.340	-19	9.750	-163	0.002	-147	0.933	170
2550	0.391	-26.9	9.230	-179	0.001	-150	0.938	169
2600	0.435	-35.2	8.760	164	0.001	-144	0.942	168
2650	0.475	-44.4	8.290	146	0.001	-137	0.945	166
2700	0.455	-46	7.050	129	0.001	-90.2	0.950	166
2750	0.535	-60.2	6.690	112	0.001	-106	0.955	164
2800	0.571	-71.2	5.980	95.1	0.001	-103	0.955	163
2850	0.598	-82	5.170	78.5	0.002	-96.5	0.954	162
2900	0.623	-92.9	4.370	63.1	0.002	-103	0.955	162
2950	0.643	-102	3.690	48.7	0.002	-96.2	0.954	161
3000	0.668	-109	3.100	35.4	0.002	-106	0.951	161
3050	0.681	-116	2.580	22.7	0.002	-107	0.952	161
3100	0.694	-121	2.130	11	0.002	-87.9	0.957	160
3150	0.712	-124	1.760	-0.057	0.002	-96.1	0.959	160
3200	0.724	-127	1.440	-10.9	0.002	-99.6	0.959	160
3250	0.726	-130	1.170	-21.1	0.002	-82.4	0.962	159
3300	0.705	-130	0.928	-28.7	0.003	-66.9	0.963	159
3350	0.743	-132	0.780	-37	0.003	-77.2	0.959	158
3400	0.748	-135	0.652	-44.3	0.003	-88	0.955	157
3450	0.753	-137	0.555	-50.3	0.003	-78.6	0.955	156

(continued)

**Table 7. Common Source S-Parameters** ( $V_{DD} = 28\text{ V}$ ,  $I_{DQ1} = 90\text{ mA}$ ,  $I_{DQ2} = 420\text{ mA}$ ,  $T_A = 25^\circ\text{C}$ , 50 Ohm System) (continued)

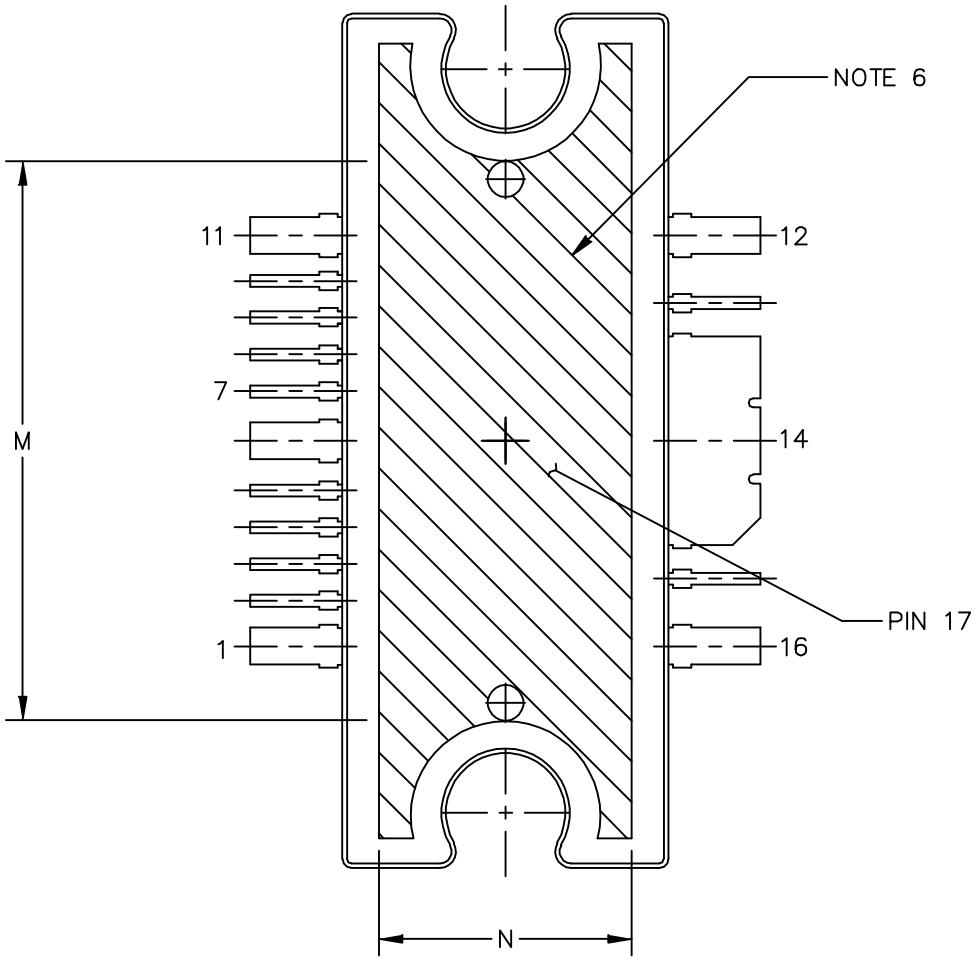
f MHz	S <sub>11</sub>		S <sub>21</sub>		S <sub>12</sub>		S <sub>22</sub>	
	S <sub>11</sub>	∠ φ	S <sub>21</sub>	∠ φ	S <sub>12</sub>	∠ φ	S <sub>22</sub>	∠ φ
3500	0.759	-140	0.486	-56.1	0.004	-81.1	0.954	155
3550	0.765	-144	0.440	-62.4	0.004	-82	0.946	154
3600	0.770	-148	0.401	-69.7	0.004	-85.9	0.941	153
3650	0.774	-153	0.370	-77.4	0.005	-96.4	0.941	151
3700	0.780	-159	0.338	-85.1	0.006	-94.9	0.940	150
3750	0.795	-164	0.306	-93.2	0.006	-99.3	0.933	148
3800	0.810	-170	0.273	-101	0.008	-110	0.928	146
3850	0.821	-175	0.239	-107	0.008	-113	0.934	145
3900	0.839	-178	0.207	-111	0.008	-112	0.936	144
3950	0.855	179	0.178	-114	0.008	-117	0.927	144
4000	0.862	176	0.156	-116	0.008	-123	0.935	144

### PACKAGE DIMENSIONS



© FREESCALE SEMICONDUCTOR, INC. ALL RIGHTS RESERVED.		MECHANICAL OUTLINE		PRINT VERSION NOT TO SCALE	
TITLE: TO-272 WIDE BODY MULTI-LEAD		DOCUMENT NO: 98ARH99164A		REV: P	
		CASE NUMBER: 1329-09		18 MAY 2010	
		STANDARD: NON-JEDEC			

MW7IC2240NR1 MW7IC2240GNR1 MW7IC2240NBR1



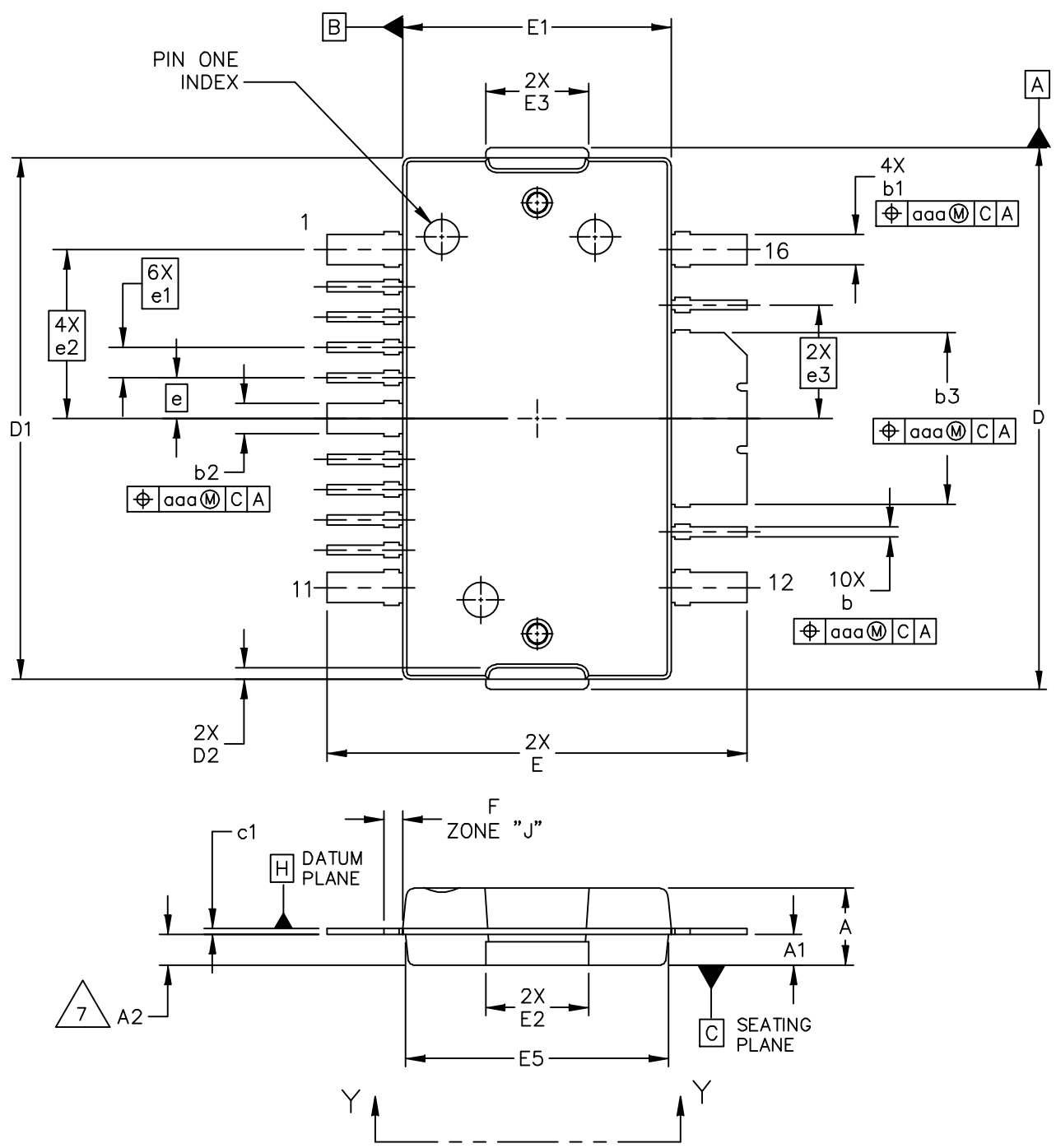
VIEW Y-Y

© FREESCALE SEMICONDUCTOR, INC. ALL RIGHTS RESERVED.	MECHANICAL OUTLINE	PRINT VERSION NOT TO SCALE	
TITLE: TO-272 WIDE BODY MULTI-LEAD	DOCUMENT NO: 98ARH99164A	REV: P	
	CASE NUMBER: 1329-09	18 MAY 2010	
	STANDARD: NON-JEDEC		

NOTES:

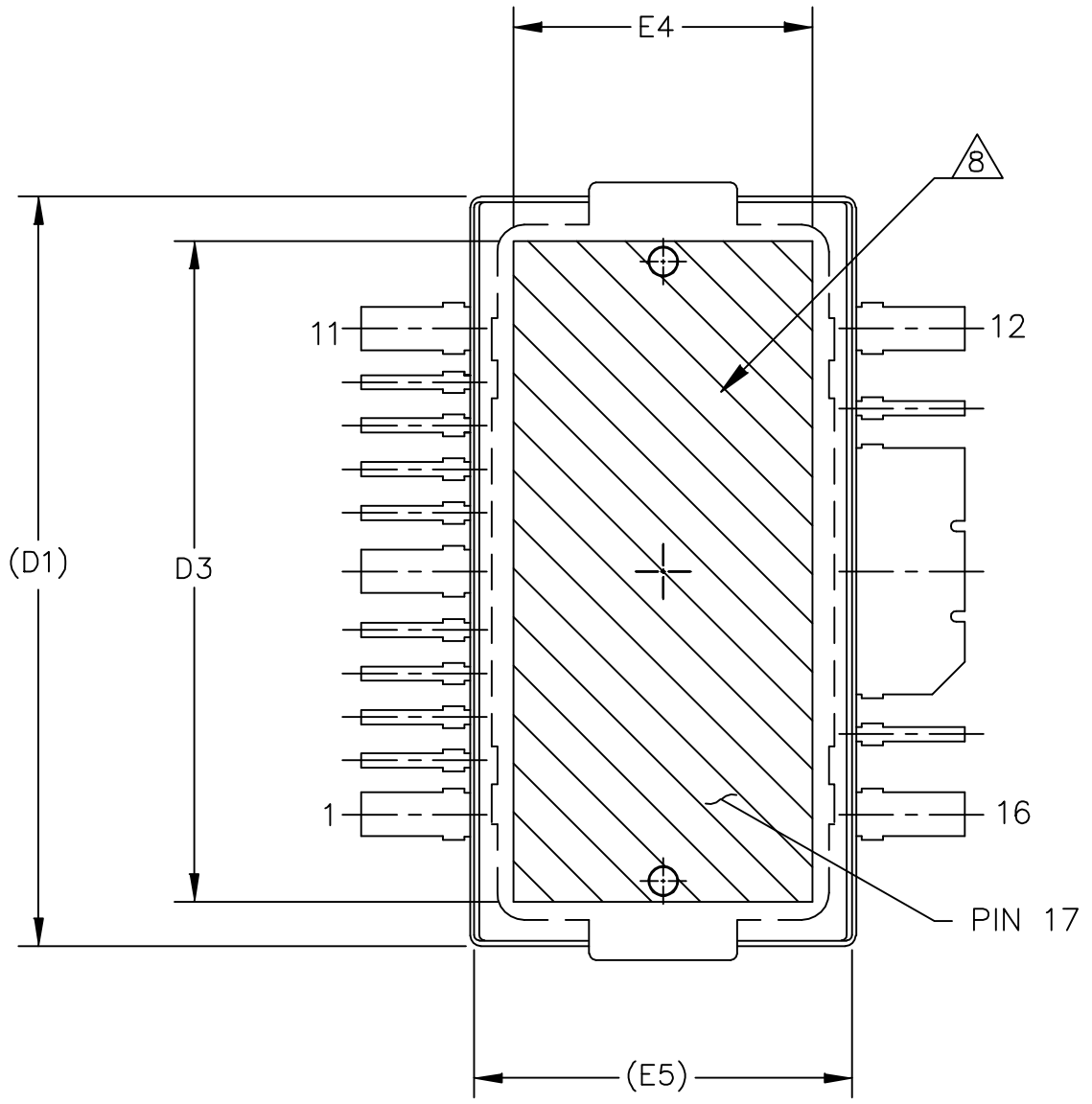
1. CONTROLLING DIMENSION: INCH
2. INTERPRET DIMENSIONS AND TOLERANCES PER ASME Y14.5M-1994.
3. DATUM PLANE -H- IS LOCATED AT THE TOP OF LEAD AND IS COINCIDENT WITH THE LEAD WHERE THE LEAD EXITS THE PLASTIC BODY AT THE TOP OF THE PARTING LINE.
4. DIMENSIONS "D" AND "E1" DO NOT INCLUDE MOLD PROTRUSION. ALLOWABLE PROTRUSION IS .006 (0.15) PER SIDE. DIMENSIONS "D" AND "E1" DO INCLUDE MOLD MISMATCH AND ARE DETERMINED AT DATUM PLANE -H-.
5. DIMENSIONS "b", "b1", "b2" AND "b3" DO NOT INCLUDE DAMBAR PROTRUSION. ALLOWABLE DAMBAR PROTRUSION SHALL BE .005 (0.13) TOTAL IN EXCESS OF THE "b", "b1", "b2" AND "b3" DIMENSIONS AT MAXIMUM MATERIAL CONDITION.
6. HATCHING REPRESENTS THE EXPOSED AREA OF THE HEAT SLUG. HATCHED AREA SHOWN IS ON THE SAME PLANE.
7. DIM A2 APPLIES WITHIN ZONE "J" ONLY.

DIM	INCH		MILLIMETER		DIM	INCH		MILLIMETER	
	MIN	MAX	MIN	MAX		MIN	MAX	MIN	MAX
A	.100	.104	2.54	2.64	b	.011	.017	0.28	0.43
A1	.038	.044	0.96	1.12	b1	.037	.043	0.94	1.09
A2	.040	.042	1.02	1.07	b2	.037	.043	0.94	1.09
D	.928	.932	23.57	23.67	b3	.225	.231	5.72	5.87
D1	.810 BSC		20.57 BSC		c1	.007	.011	.18	.28
E	.551	.559	14.00	14.20	e	.054 BSC		1.37 BSC	
E1	.353	.357	8.97	9.07	e1	.040 BSC		1.02 BSC	
E2	.346	.350	8.79	8.89	e2	.224 BSC		5.69 BSC	
F	.025 BSC		0.64 BSC		e3	.150 BSC		3.81 BSC	
M	.600	----	15.24	----	r1	.063	.068	1.6	1.73
N	.270	----	6.86	----	aaa	.004		.10	
© FREESCALE SEMICONDUCTOR, INC. ALL RIGHTS RESERVED.			MECHANICAL OUTLINE			PRINT VERSION NOT TO SCALE			
TITLE: TO-272 WIDE BODY MULTI-LEAD					DOCUMENT NO: 98ARH99164A			REV: P	
					CASE NUMBER: 1329-09			18 MAY 2010	
					STANDARD: NON-JEDEC				



© FREESCALE SEMICONDUCTOR, INC. ALL RIGHTS RESERVED.	MECHANICAL OUTLINE	PRINT VERSION NOT TO SCALE	
TITLE: TO-270 WIDE BODY 16 LEAD	DOCUMENT NO: 98ASA10754D	REV: C	
	CASE NUMBER: 1886-01	18 MAY 2010	
	STANDARD: NON-JEDEC		





VIEW Y-Y

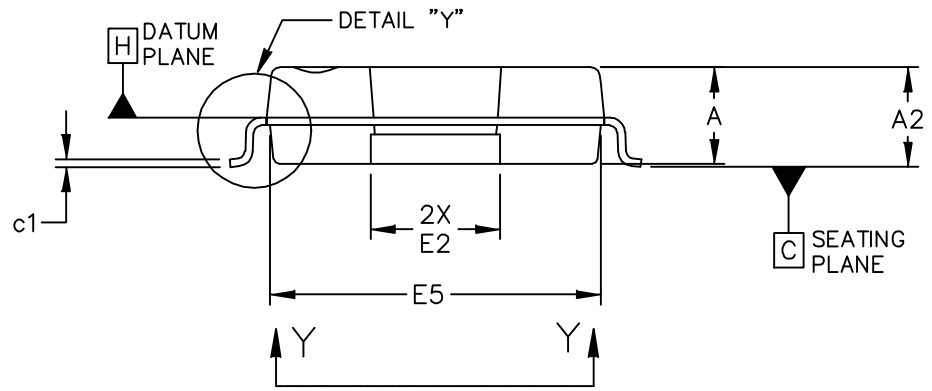
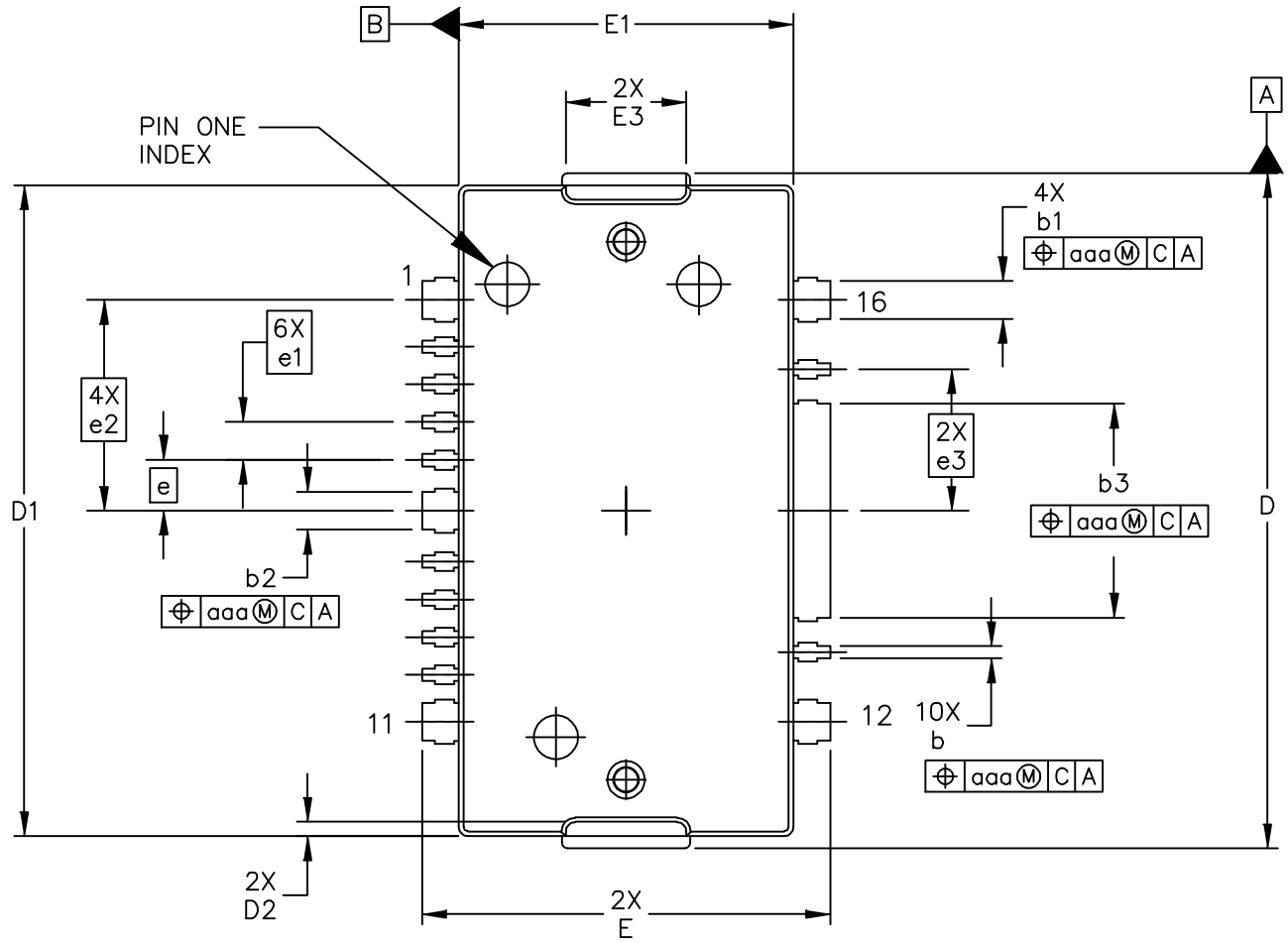
© FREESCALE SEMICONDUCTOR, INC. ALL RIGHTS RESERVED.	MECHANICAL OUTLINE	PRINT VERSION NOT TO SCALE	
TITLE: TO-270 WIDE BODY 16 LEAD	DOCUMENT NO: 98ASA10754D	REV: C	
	CASE NUMBER: 1886-01	18 MAY 2010	
	STANDARD: NON-JEDEC		

MW7IC2240NR1 MW7IC2240GNR1 MW7IC2240NBR1

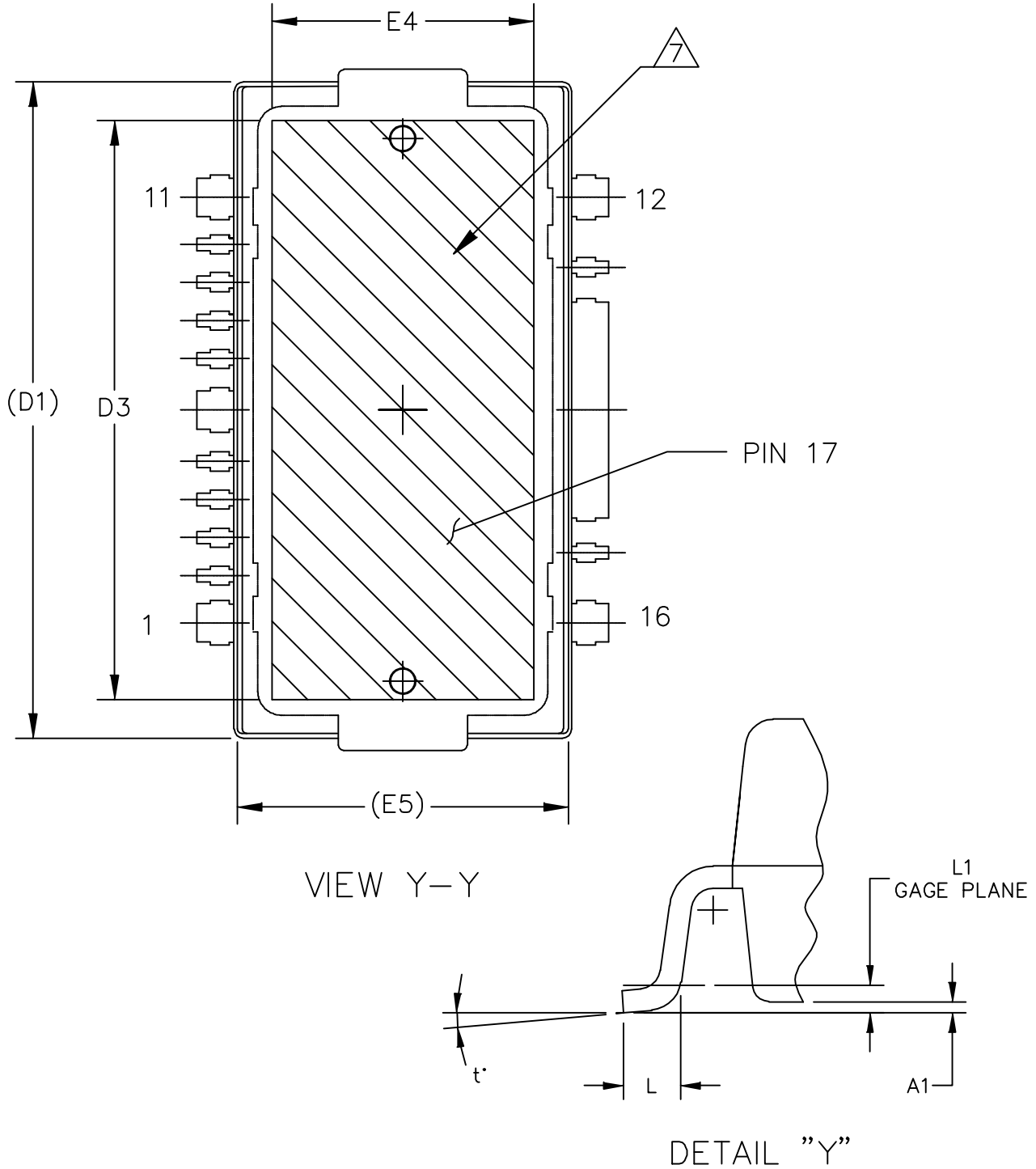
NOTES:

1. CONTROLLING DIMENSION: INCH
2. INTERPRET DIMENSIONS AND TOLERANCES PER ASME Y14.5M-1994.
3. DATUM PLANE -H- IS LOCATED AT THE TOP OF LEAD AND IS COINCIDENT WITH THE LEAD WHERE THE LEAD EXITS THE PLASTIC BODY AT THE TOP OF THE PARTING LINE.
4. DIMENSIONS "D" AND "E1" DO NOT INCLUDE MOLD PROTRUSION. ALLOWABLE PROTRUSION IS .006 (0.15) PER SIDE. DIMENSIONS "D" AND "E1" DO INCLUDE MOLD MISMATCH AND ARE DETERMINED AT DATUM PLANE -H-.
5. DIMENSIONS "b", "b1", "b2" AND "b3" DO NOT INCLUDE DAMBAR PROTRUSION. ALLOWABLE DAMBAR PROTRUSION SHALL BE .005 (0.13) TOTAL IN EXCESS OF THE "b", "b1", "b2" AND "b3" DIMENSIONS AT MAXIMUM MATERIAL CONDITION.
6. DATUM -A- AND -B- TO BE DETERMINED AT DATUM PLANE -H-.
7. DIMENSION A2 APPLIES WITHIN ZONE "J" ONLY.
8. HATCHING REPRESENTS THE EXPOSED AREA OF THE HEAT SLUG. HATCHED AREA SHOWN IS ON THE SAME PLANE.

DIM	INCH		MILLIMETER		DIM	INCH		MILLIMETER	
	MIN	MAX	MIN	MAX		MIN	MAX	MIN	MAX
A	.100	.104	2.54	2.64	F	.025 BSC		0.64 BSC	
A1	.039	.043	0.99	1.09	b	.011	.017	0.28	0.43
A2	.040	.042	1.02	1.07	b1	.037	.043	0.94	1.09
D	.712	.720	18.08	18.29	b2	.037	.043	0.94	1.09
D1	.688	.692	17.48	17.58	b3	.225	.231	5.72	5.87
D2	.011	.019	0.28	0.48	c1	.007	.011	.18	.28
D3	.600	---	15.24	---	e	.054 BSC		1.37 BSC	
E	.551	.559	14	14.2	e1	.040 BSC		1.02 BSC	
E1	.353	.357	8.97	9.07	e2	.224 BSC		5.69 BSC	
E2	.132	.140	3.35	3.56	e3	.150 BSC		3.81 BSC	
E3	.124	.132	3.15	3.35	aaa	.004		.10	
E4	.270	---	6.86	---					
E5	.346	.350	8.79	8.89					
© FREESCALE SEMICONDUCTOR, INC. ALL RIGHTS RESERVED.			MECHANICAL OUTLINE			PRINT VERSION NOT TO SCALE			
TITLE: TO-270 WIDE BODY 16 LEAD					DOCUMENT NO: 98ASA10754D			REV: C	
					CASE NUMBER: 1886-01			18 MAY 2010	
					STANDARD: NON-JEDEC				



© FREESCALE SEMICONDUCTOR, INC. ALL RIGHTS RESERVED.		MECHANICAL OUTLINE		PRINT VERSION NOT TO SCALE	
TITLE:	TO-270 WIDE BODY 16 LEAD, GULL WING		DOCUMENT NO: 98ASA10755D		REV: A
			CASE NUMBER: 1887-01		31 AUG 2007
			STANDARD: NON-JEDEC		



© FREESCALE SEMICONDUCTOR, INC. ALL RIGHTS RESERVED.		MECHANICAL OUTLINE	PRINT VERSION NOT TO SCALE
TITLE: TO-270 WIDE BODY 16 LEAD, GULL WING	DOCUMENT NO: 98ASA10755D		REV: A
	CASE NUMBER: 1887-01		31 AUG 2007
	STANDARD: NON-JEDEC		

NOTES:

1. CONTROLLING DIMENSION: INCH
2. INTERPRET DIMENSIONS AND TOLERANCES PER ASME Y14.5M-1994.
3. DATUM PLANE -H- IS LOCATED AT THE TOP OF LEAD AND IS COINCIDENT WITH THE LEAD WHERE THE LEAD EXITS THE PLASTIC BODY AT THE TOP OF THE PARTING LINE.
4. DIMENSIONS "D" AND "E1" DO NOT INCLUDE MOLD PROTRUSION. ALLOWABLE PROTRUSION IS .006 (0.15) PER SIDE. DIMENSIONS "D" AND "E1" DO INCLUDE MOLD MISMATCH AND ARE DETERMINED AT DATUM PLANE -H-.
5. DIMENSIONS "b", "b1", "b2" AND "b3" DO NOT INCLUDE DAMBAR PROTRUSION. ALLOWABLE DAMBAR PROTRUSION SHALL BE .005 (0.13) TOTAL IN EXCESS OF THE "b", "b1", "b2" AND "b3" DIMENSIONS AT MAXIMUM MATERIAL CONDITION.
6. DATUM -A- AND -B- TO BE DETERMINED AT DATUM PLANE -H-.
7. HATCHING REPRESENTS EXPOSED AREA OF THE HEAT SLUG. HATCHED AREA SHOWN IS ON THE SAME PLANE.

DIM	INCH		MILLIMETER		DIM	INCH		MILLIMETER	
	MIN	MAX	MIN	MAX		MIN	MAX	MIN	MAX
A	.100	.104	2.54	2.64	L	.018	.024	0.46	0.61
A1	.001	.004	0.02	0.10	L1	.010 BSC		0.25 BSC	
A2	.099	.110	2.51	2.79	b	.011	.017	0.28	0.43
D	.712	.720	18.08	18.29	b1	.037	.043	0.94	1.09
D1	.688	.692	17.48	17.58	b2	.037	.043	0.94	1.09
D2	.011	.019	0.28	0.48	b3	.225	.231	5.72	5.87
D3	.600	---	15.24	---	c1	.007	.011	0.18	0.28
E	.429	.437	10.9	11.1	e	.054 BSC		1.37 BSC	
E1	.353	.357	8.97	9.07	e1	.040 BSC		1.02 BSC	
E2	.132	.140	3.35	3.56	e2	.224 BSC		5.69 BSC	
E3	.124	.132	3.15	3.35	e3	.150 BSC		3.81 BSC	
E4	.270	---	6.86	---	t	2'	8'	2'	8'
E5	.346	.350	8.79	8.89	aaa	.004		0.10	
© FREESCALE SEMICONDUCTOR, INC. ALL RIGHTS RESERVED.			MECHANICAL OUTLINE			PRINT VERSION NOT TO SCALE			
TITLE: TO-270 WIDE BODY 16 LEAD, GULL WING					DOCUMENT NO: 98ASA10755D			REV: A	
					CASE NUMBER: 1887-01			31 AUG 2007	
					STANDARD: NON-JEDEC				

## PRODUCT DOCUMENTATION AND SOFTWARE

Refer to the following documents and software to aid your design process.

### Application Notes

- AN1907: Solder Reflow Attach Method for High Power RF Devices in Plastic Packages
- AN1955: Thermal Measurement Methodology of RF Power Amplifiers
- AN1977: Quiescent Current Thermal Tracking Circuit in the RF Integrated Circuit Family
- AN1987: Quiescent Current Control for the RF Integrated Circuit Device Family
- AN3263: Bolt Down Mounting Method for High Power RF Transistors and RFICs in Over-Molded Plastic Packages
- AN3789: Clamping of High Power RF Transistors and RFICs in Over-Molded Plastic Packages

### Engineering Bulletins

- EB212: Using Data Sheet Impedances for RF LDMOS Devices

### Software

- Electromigration MTTF Calculator
- RF High Power Model

For Software, do a Part Number search at <http://www.freescale.com>, and select the “Part Number” link. Go to the Software & Tools tab on the part’s Product Summary page to download the respective tool.

## REVISION HISTORY

The following table summarizes revisions to this document.

Revision	Date	Description
0	Nov. 2007	<ul style="list-style-type: none"> <li>• Initial Release of Data Sheet</li> </ul>
1	June 2011	<ul style="list-style-type: none"> <li>• Modified data sheet to reflect RF Test Reduction described in Product and Process Change Notification number, PCN13628, p. 1, 4</li> <li>• Changed ESD Human Body Model rating from Class 1B to Class 0 to reflect recent ESD test results of the device, p. 2</li> <li>• Fig. 17, MTTF versus Junction Temperature removed, p. 9. Refer to the device’s MTTF Calculator available at <a href="http://freescale.com/RFpower">freescale.com/RFpower</a>. Go to Design Resources &gt; Software and Tools.</li> <li>• Fig. 18, CCDF W-CDMA IQ Magnitude Clipping, Single-Carrier Test Signal and Fig. 19, Single-Carrier W-CDMA Spectrum updated to show the undistorted input test signal, p. 9 (renumbered as Fig. 17 and Fig. 18 after Fig. 17 removed)</li> <li>• Added AN1977, Quiescent Current Thermal Tracking Circuit in the RF Integrated Circuit Family, AN1987, Quiescent Current Control for the RF Integrated Circuit Device Family, and AN3789, Clamping of High Power RF Transistors and RFICs in Over-Molded Plastic Packages to Product Documentation, Application Notes, p. 22</li> <li>• Added Electromigration MTTF Calculator and RF High Power Model availability to Product Software, p. 22</li> </ul>

## **How to Reach Us:**

### **Home Page:**

[www.freescale.com](http://www.freescale.com)

### **Web Support:**

<http://www.freescale.com/support>

### **USA/Europe or Locations Not Listed:**

Freescale Semiconductor, Inc.  
Technical Information Center, EL516  
2100 East Elliot Road  
Tempe, Arizona 85284  
1-800-521-6274 or +1-480-768-2130  
[www.freescale.com/support](http://www.freescale.com/support)

### **Europe, Middle East, and Africa:**

Freescale Halbleiter Deutschland GmbH  
Technical Information Center  
Schatzbogen 7  
81829 Muenchen, Germany  
+44 1296 380 456 (English)  
+46 8 52200080 (English)  
+49 89 92103 559 (German)  
+33 1 69 35 48 48 (French)  
[www.freescale.com/support](http://www.freescale.com/support)

### **Japan:**

Freescale Semiconductor Japan Ltd.  
Headquarters  
ARCO Tower 15F  
1-8-1, Shimo-Meguro, Meguro-ku,  
Tokyo 153-0064  
Japan  
0120 191014 or +81 3 5437 9125  
[support.japan@freescale.com](mailto:support.japan@freescale.com)

### **Asia/Pacific:**

Freescale Semiconductor China Ltd.  
Exchange Building 23F  
No. 118 Jianguo Road  
Chaoyang District  
Beijing 100022  
China  
+86 10 5879 8000  
[support.asia@freescale.com](mailto:support.asia@freescale.com)

### **For Literature Requests Only:**

Freescale Semiconductor Literature Distribution Center  
1-800-441-2447 or +1-303-675-2140  
Fax: +1-303-675-2150  
[LDCForFreescaleSemiconductor@hibbertgroup.com](mailto:LDCForFreescaleSemiconductor@hibbertgroup.com)

Information in this document is provided solely to enable system and software implementers to use Freescale Semiconductor products. There are no express or implied copyright licenses granted hereunder to design or fabricate any integrated circuits or integrated circuits based on the information in this document.

Freescale Semiconductor reserves the right to make changes without further notice to any products herein. Freescale Semiconductor makes no warranty, representation or guarantee regarding the suitability of its products for any particular purpose, nor does Freescale Semiconductor assume any liability arising out of the application or use of any product or circuit, and specifically disclaims any and all liability, including without limitation consequential or incidental damages. "Typical" parameters that may be provided in Freescale Semiconductor data sheets and/or specifications can and do vary in different applications and actual performance may vary over time. All operating parameters, including "Typicals", must be validated for each customer application by customer's technical experts. Freescale Semiconductor does not convey any license under its patent rights nor the rights of others. Freescale Semiconductor products are not designed, intended, or authorized for use as components in systems intended for surgical implant into the body, or other applications intended to support or sustain life, or for any other application in which the failure of the Freescale Semiconductor product could create a situation where personal injury or death may occur. Should Buyer purchase or use Freescale Semiconductor products for any such unintended or unauthorized application, Buyer shall indemnify and hold Freescale Semiconductor and its officers, employees, subsidiaries, affiliates, and distributors harmless against all claims, costs, damages, and expenses, and reasonable attorney fees arising out of, directly or indirectly, any claim of personal injury or death associated with such unintended or unauthorized use, even if such claim alleges that Freescale Semiconductor was negligent regarding the design or manufacture of the part.

Freescale™ and the Freescale logo are trademarks of Freescale Semiconductor, Inc. All other product or service names are the property of their respective owners.

© Freescale Semiconductor, Inc. 2007, 2011. All rights reserved.



Компания «ЭлектроПласт» предлагает заключение долгосрочных отношений при поставках импортных электронных компонентов на взаимовыгодных условиях!

Наши преимущества:

- Оперативные поставки широкого спектра электронных компонентов отечественного и импортного производства напрямую от производителей и с крупнейших мировых складов;
- Поставка более 17-ти миллионов наименований электронных компонентов;
- Поставка сложных, дефицитных, либо снятых с производства позиций;
- Оперативные сроки поставки под заказ (от 5 рабочих дней);
- Экспресс доставка в любую точку России;
- Техническая поддержка проекта, помощь в подборе аналогов, поставка прототипов;
- Система менеджмента качества сертифицирована по Международному стандарту ISO 9001;
- Лицензия ФСБ на осуществление работ с использованием сведений, составляющих государственную тайну;
- Поставка специализированных компонентов (Xilinx, Altera, Analog Devices, Intersil, Interpoint, Microsemi, Aeroflex, Peregrine, Syfer, Eurofarad, Texas Instrument, Miteq, Cobham, E2V, MA-COM, Hittite, Mini-Circuits, General Dynamics и др.);

Помимо этого, одним из направлений компании «ЭлектроПласт» является направление «Источники питания». Мы предлагаем Вам помощь Конструкторского отдела:

- Подбор оптимального решения, техническое обоснование при выборе компонента;
- Подбор аналогов;
- Консультации по применению компонента;
- Поставка образцов и прототипов;
- Техническая поддержка проекта;
- Защита от снятия компонента с производства.



#### Как с нами связаться

**Телефон:** 8 (812) 309 58 32 (многоканальный)

**Факс:** 8 (812) 320-02-42

**Электронная почта:** [org@eplast1.ru](mailto:org@eplast1.ru)

**Адрес:** 198099, г. Санкт-Петербург, ул. Калинина, дом 2, корпус 4, литера А.