

DESIGN NOTES

High Frequency Amplifier Evaluation Board – Design Note 50

Mitchell Lee

Introduction

Demo board DC009 is designed to simplify the evaluation of high speed operational amplifiers. It includes both an inverting and non-inverting circuit, and pads are provided to allow the use of board-mounted BNC or SMA connectors. The two circuits are independent, with the exception of shared power supply and ground connections.

High Speed Layout Techniques

Layout is a primary contributor to the performance of any high speed amplifier. Poor layout techniques adversely affect the behavior of a finished circuit. Several important layout techniques, all used in demo board DC009, are described below:

Top Side Ground Plane: The primary task of a ground plane is to lower the impedance of ground connections. The inductance between any two points on a uniform sheet of copper is less than the inductance of a narrow, straight trace of copper connecting the same two points. The ground plane approximates the characteristics of a copper sheet and lowers the impedance at key points in the circuit, such as at the grounds of connectors and supply bypass capacitors.

Ground Plane Voids: Certain components and circuit nodes are very sensitive to stray capacitance. Two good examples are the summing node of the op amp and the feedback resistor. Voids are put in the ground plane in these areas to reduce stray ground capacitance.

Input/Output Matching: The width of the input and output traces is adjusted to a stripline impedance of 50Ω. Note that the terminating resistors (R3 and R7) are connected to the end of the input lines — not at the connector. While stripline techniques aren't absolutely necessary for the demo board, they are important on larger layouts where line lengths are longer. The short lines on the demo board can be terminated in 50Ω, 75Ω, or 93Ω without adversely affecting performance.

Separation of Input and Output Grounds: Even though the ground plane exhibits a low impedance, input and output

grounds are still separated. For example, the termination resistors (R3 and R7) and the gain-setting resistor (R1) are grounded in the vicinity of the input connector. Supply bypass capacitors (C1, C2, C4, C5, C7, C8, C9, and C10) are returned to ground in the vicinity of the output connectors.

Optional Components

The circuit board is designed to accommodate standard 8-pin miniDIP, single operational amplifiers, such as the LT1190 and LT1220 families. Both voltage and current feedback types can be used. Pins 1, 5, and 8 are outfitted with pads for use in adjusting DC offsets, compensation or, in the case of the LT1223 and LT1190/1/2, for shutting down the amplifier.

If a current feedback amplifier such as the LT1223 is being evaluated, omit C3/C6. R4 and R8 are included for impedance matching when driving low impedance lines. If the amplifier is supposed to drive the line directly, or if the load impedance is high, R4 and R8 can be replaced by jumpers. Similarly R10 and R12 can be used to establish a load at the output of the amplifier.

Low profile sockets may be used for the op amps to facilitate changing parts, but performance may be affected above 100MHz.

Supply Bypass Capacitors

High speed operational amplifiers work best when their supply pins are bypassed with RF-quality capacitors. C1, C5, C8, and C10 should be 10nF disc ceramics with a self-resonant frequency greater than 10MHz. The polarized capacitors (C2, C4, C7, and C9) should be 1μF to 10μF tantalums. Most 10nF ceramics are self-resonant well above 10MHz, and 4.7μF solid tantalums (axial leaded) are self-resonant at 1MHz or below. Lead lengths are critical: the self-resonant frequency of a 4.7μF tantalum drops by a factor of 2 when measured through 2 inch leads. Although a capacitor may become inductive at high frequencies, it is still an effective bypass component above resonance because the impedance is low.

Demo DC009 High Frequency Amplifier

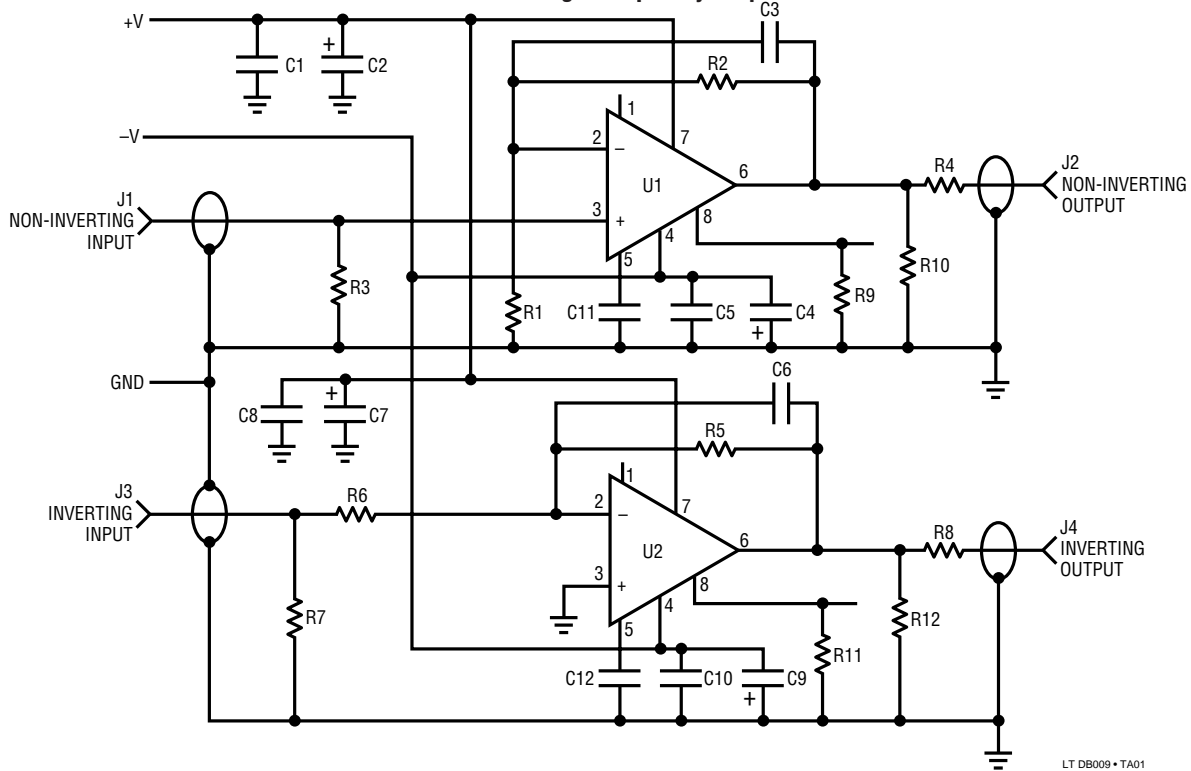

Demo Board DC009 Parts List

Non-inverting Amplifier:

- R1 Gain Setting Resistor
- R2 Feedback Resistor
- R3 Input Line Termination (51Ω)
- R4 Output Line Termination (51Ω)
- R9 Shutdown Pin Pull Down
- R10 Output Load Resistor
- C1 Positive Supply High Frequency Bypass (10nF)
- C2 Positive Supply Low Frequency Bypass (4.7μF)
- C3 Feedback Capacitor
- C4 Negative Supply Low Frequency Bypass (4.7μF)
- C5 Negative Supply High Frequency Bypass (10nF)
- C11 Compensation Capacitor
- J1 Input Connector (AMP 227699-3)
- J2 Output Connector (AMP 227699-3)

Inverting Amplifier:

- R5 Feedback Resistor
- R6 Gain Setting Resistor
- R7 Input Line Termination (51Ω)
- R8 Output Line Termination (51Ω)
- R11 Shutdown Pin Pull Down
- R12 Output Load Resistor
- C6 Feedback Capacitor
- C7 Positive Supply Low Frequency Bypass (4.7μF)
- C8 Positive Supply High Frequency Bypass (10nF)
- C9 Negative Supply Low Frequency Bypass (4.7μF)

- C10 Negative Supply High Frequency Bypass (10nF)
- C12 Compensation Capacitor
- J3 Input Connector (AMP 227699-3)
- J4 Output Connector (AMP 227699-3)

High Frequency Amplifier, Demo 009A Component Side

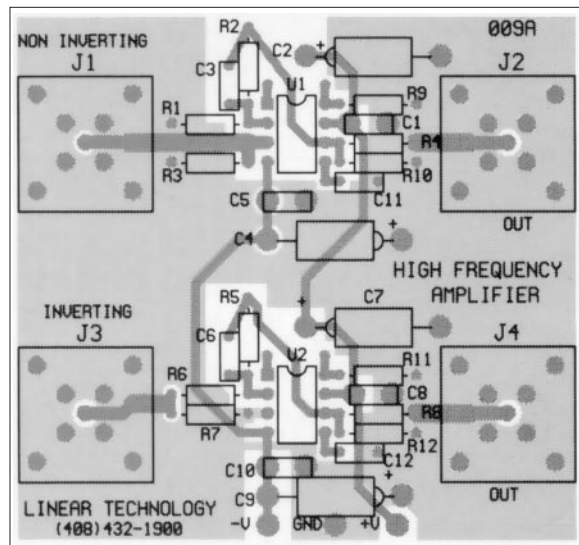

For literature on our High Speed Amplifiers, call (800) 637-5545. For applications help, call (408) 432-1900, Ext. 456.

Linear Technology Corporation

1630 McCarthy Blvd., Milpitas, CA 95035-7487
 (408) 432-1900 • FAX: (408) 434-0507 • TELEX: 499-3977

BA/GP 0691 10K REV 0



© LINEAR TECHNOLOGY CORPORATION 1991



Компания «ЭлектроПласт» предлагает заключение долгосрочных отношений при поставках импортных электронных компонентов на взаимовыгодных условиях!

Наши преимущества:

- Оперативные поставки широкого спектра электронных компонентов отечественного и импортного производства напрямую от производителей и с крупнейших мировых складов;
- Поставка более 17-ти миллионов наименований электронных компонентов;
- Поставка сложных, дефицитных, либо снятых с производства позиций;
- Оперативные сроки поставки под заказ (от 5 рабочих дней);
- Экспресс доставка в любую точку России;
- Техническая поддержка проекта, помощь в подборе аналогов, поставка прототипов;
- Система менеджмента качества сертифицирована по Международному стандарту ISO 9001;
- Лицензия ФСБ на осуществление работ с использованием сведений, составляющих государственную тайну;
- Поставка специализированных компонентов (Xilinx, Altera, Analog Devices, Intersil, Interpoint, Microsemi, Aeroflex, Peregrine, Syfer, Eurofarad, Texas Instrument, Miteq, Cobham, E2V, MA-COM, Hittite, Mini-Circuits, General Dynamics и др.);

Помимо этого, одним из направлений компании «ЭлектроПласт» является направление «Источники питания». Мы предлагаем Вам помощь Конструкторского отдела:

- Подбор оптимального решения, техническое обоснование при выборе компонента;
- Подбор аналогов;
- Консультации по применению компонента;
- Поставка образцов и прототипов;
- Техническая поддержка проекта;
- Защита от снятия компонента с производства.



Как с нами связаться

Телефон: 8 (812) 309 58 32 (многоканальный)

Факс: 8 (812) 320-02-42

Электронная почта: org@eplast1.ru

Адрес: 198099, г. Санкт-Петербург, ул. Калинина, дом 2, корпус 4, литера А.