

### Features

- Supports Hybrid Mode (using SyncE for frequency synchronization and IEEE 1588 for phase alignment)
- Recovers and transmits network synchronization over Ethernet, IP and MPLS Networks
- Simultaneously supports both the Synchronous Ethernet and the IEEE1588 industry standard timing protocols
- Capable of server, client and boundary clock operationIntegrates two separate digital phase locked loops, with hitless switching between packet and electrical clock references
- Primary DPLL meets Stratum 3 quality
- Targeted for synchronization distribution to better than ITU-T G.8261, G.823, G.824 and ANSI T1.101 synchronization interface standards
- Average frequency accuracy better than  $\pm 10$  ppb
- Aligns to a low frequency input signal at server (e.g., 1 Hz) with targeted accuracy better than  $\pm 1$   $\mu$ s
- Recovers clocks from two independent servers, with hitless switching between packet streams for redundancy
- Supports ITU-T recommendations G.8262 (Option 1)
- Supports holdover if the server stream is lost

### Ordering Information

ZL30314GKG 256 TEPBGA, 17 x 17 mm  
 ZL30314GKG2\* 256 TEPBGA, 17 x 17 mm  
 \* Pb Free Tin/Silver/Copper

**-40°C to +85°C**

- Accepts eight input references, and up to three associated low frequency alignment or framing pulses
- Generates up to four separate output clocks at frequencies between 8 kHz and 100 MHz
- Generates two separate Synchronous Ethernet clocks to drive industry standard Ethernet PHY devices at either 25 MHz or 125 MHz
- Fully configurable solution, enabling performance to be tailored to application/network requirements
- Two independently configurable MAC interfaces, supporting MII, RMII, GMII and TBI standards
- Wire-speed Ethernet Bridge pass through function between the MAC interfaces
- Synchronous serial control interface
- Full demonstration & evaluation platform available

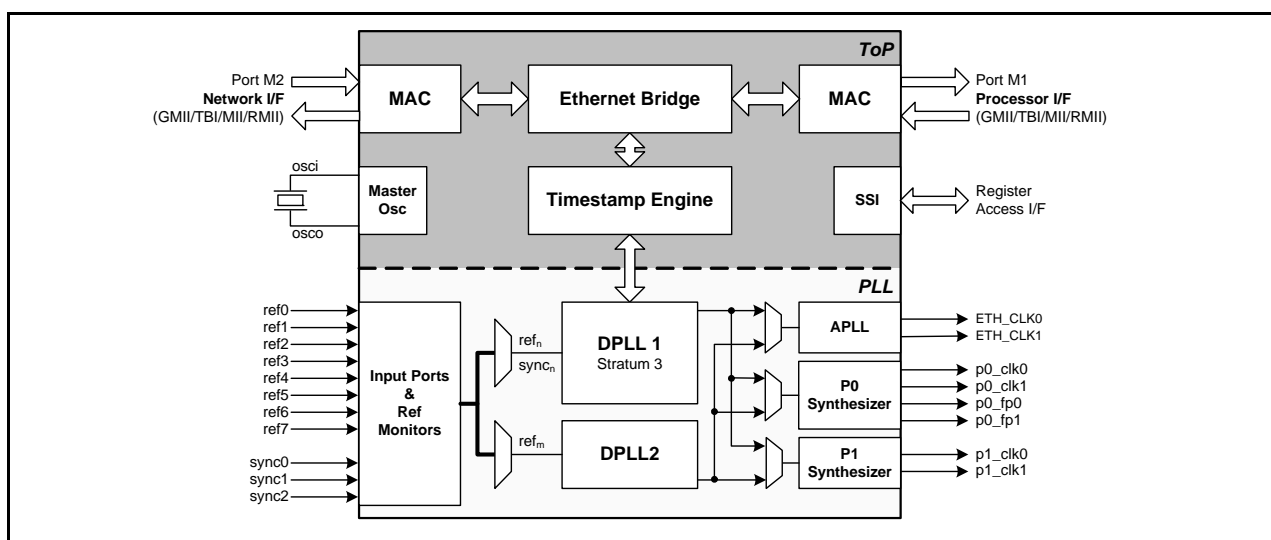

**Figure 1 - ZL30314 Functional Block Diagram**

## Applications

- IEEE 1588 and Synchronous Ethernet timing
- GSM and UMTS air interface synchronization over a packet network
- Circuit Emulation Services over Packets
- IP-PBX and VoIP Gateways
- Video Conferencing
- Broadband Video Distribution

## Description

Network infrastructures are gradually converging onto a packet-based architecture. With this convergence, there are a significant number of synchronous applications that require accurate timing to be distributed over the packet networks. Examples of precision timing sensitive applications that need the transport of synchronization over packet networks include transport of TDM over packet networks, connections to 2 G and 3 G cellular base stations, Voice over IP, IP PBXs, video-conferencing and broadband video.

There are two main ways to enable synchronization over a packet network, synchronizing the packet network itself, as in the Synchronous Ethernet approach, or distributing the timing using the packets as in Microsemi's Timing over Packet (ToP) technology. The two techniques can also be combined to provide a very powerful hybrid solution. Synchronous Ethernet delivers a very accurate frequency reference, but doesn't address phase and time synchronization. ToP can be used to supplement the excellent frequency distribution of Synchronous Ethernet with accurate phase and time information. Alternatively, ToP can be used to extend the reach of the Synchronous Ethernet reference across an asynchronous network, such as a LAN connected to a synchronous WAN.

Microsemi has combined both methods into a single device. The ZL30314 incorporates an extremely low-jitter frequency synthesizer, capable of generating all the frequencies required for Synchronous Ethernet operation, together with Microsemi's patent-pending Timing over Packet (ToP) technology based on the industry-standard IEEE1588™ "PTP" (Precision Time Protocol). Not only can it function as a fully-featured Digital PLL, it also supports the distribution of time, phase and frequency across both layer 2 and layer 3 networks, using both Synchronous Ethernet and IEEE1588 protocols, either alone or in combination.

The ZL30314 is a member of a family of footprint-compatible devices offering the full range of features required for timing and synchronization across the packet network. These devices facilitate design of a flexible card that can be upgraded as required by simply placing another member of the same family.

The family members include:

ZL30310	Combined IEEE1588™ ToP and Synchronous Ethernet, coupled with a GR-1244 Stratum 3E/3/4/4E and GR-253 SONET and G.813 quality phase locked loop for timing card applications, plus a second independent PLL for rate conversion or generation of additional derived clocks.
ZL30312	Combined IEEE1588™ ToP and Synchronous Ethernet, coupled with a GR-1244 Stratum 3/4/4E and GR-253 SEONET and G.813 quality phase locked loop for timing card applications, plus a second independent PLL for rate conversion or generation of additional derived clocks.
ZL30314	Combined IEEE1588™ ToP and Synchronous Ethernet, coupled with a GR1244 Stratum 3/4/4E and G.813 Option 1 quality phase locked loop for timing card applications, plus a second independent PLL for rate conversion or generation of additional derived clocks.
ZL30316	Combined IEEE1588™ ToP and Synchronous Ethernet, coupled with two independent, flexible phase locked loops for line card applications
ZL30320	Combined IEEE1588™ ToP and Synchronous Ethernet for line card applications
ZL30321	Synchronous Ethernet line card device in a ToP compatible footprint, containing two independent DPLLs

The Microsemi device offers the following clock routing options:

Input	Output	Description
clock reference	clock	conventional PLL behaviour, <i>e.g., Synchronous Ethernet node</i>
clock reference	packet stream	server behaviour, <i>e.g., IEEE1588 server</i>
clock reference	clock and/or packet stream	conventional PLL behaviour coupled with packet time server, <i>e.g., combined Synchronous Ethernet and IEEE1588 server</i>
packet reference	clock	client behaviour, <i>e.g., IEEE1588 client</i>
clock and/or packet reference	clock	conventional PLL behaviour, coupled with packet time client, either as fail-over from one to the other, or in combination <i>e.g., combined Synchronous Ethernet and IEEE1588 client</i>
packet reference	clock and/or packet stream	combination of client and boundary clock behaviour, <i>e.g., IEEE1588 boundary clock</i>

When operating as a server, the Microsemi device locks onto the incoming clock reference as a conventional PLL, filtering any jitter that may be present. It also synchronizes to any low-frequency alignment signal, e.g., an 8 kHz TDM frame pulse, or a 1 Hz alignment input. The device delivers streams of packets, each containing a timestamp indicating the precise time that the packet was launched into the network, relative to the acquired reference. It also receives packets from clients, and returns a message indicating the exact time that the client message was received at the server. Using this information, clients are able to align their own timebase with that of the server.

As a client, the Microsemi device can track two independent servers, and determine which one is providing the best time reference. If either the primary reference or the network between the server and client fails, the device can switch to the alternative reference without introducing a phase discontinuity. Alternatively, the client can switch to a conventional clock reference.

The solution timing recovery algorithm continuously tracks the frequency offset and phase drift between the clocks located at the server and the client nodes connected via the packet switched network. The algorithm is tolerant of lost packets, and of packet delay variation caused by packet queuing, route changes and other effects. In the event of a failure in the packet network, or the advent of severe congestion preventing or seriously delaying the delivery of timing packets, the device will put the recovered clocks into holdover until the flow of timing packets is restored. When the device is in holdover mode the drift of the local oscillator directly affects the accuracy of the output clocks.

When using ToP technology, the device is designed to meet ANSI standard T1.101 and ITU-T standards G.823 and G.824 for synchronization distribution. It maintains a mean frequency accuracy of better than  $\pm 10$  ppb and time alignment of better than  $\pm 1$   $\mu$ s when operated over a suitable network.

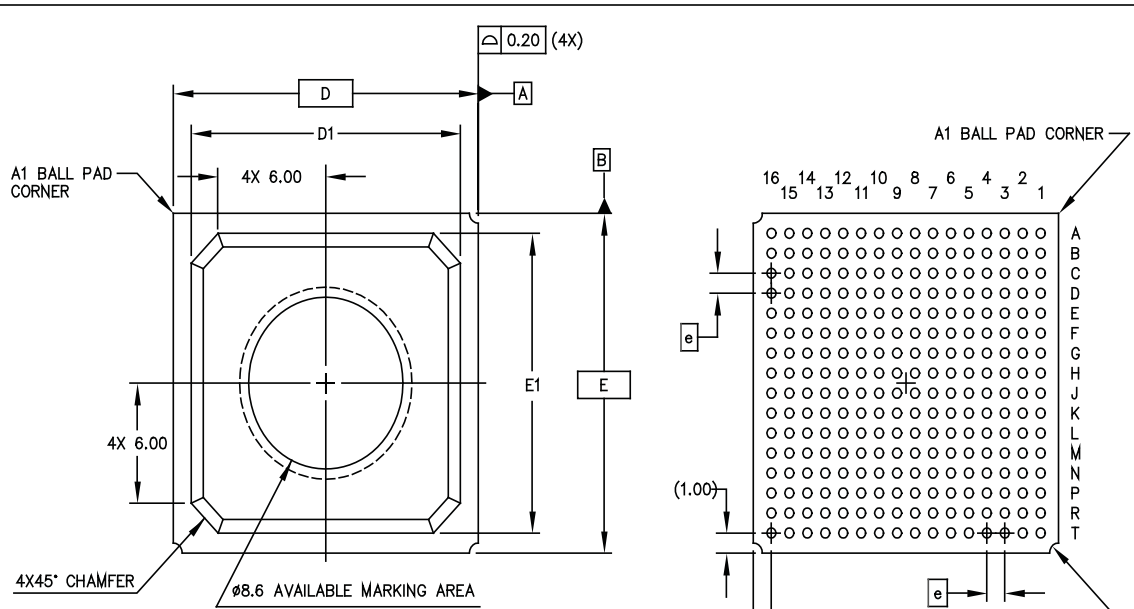

DIMENSION	MIN	Nom	MAX
A	1.55	1.76	1.97
A1	0.30	0.40	0.50
A2	0.75	0.80	0.85
A3	0.50	0.56	0.62
D	16.80	17.00	17.20
D1	14.95	15.00	15.35
E	16.80	17.00	17.20
E1	14.95	15.00	15.35
b	0.40	0.50	0.60
e	1.00		
N	256		

Conforms to JEDEC MS-034/B except dimension 'b'  
JEDEC "b" 0.6 +/- 0.1mm

TOP VIEW

BOTTOM VIEW

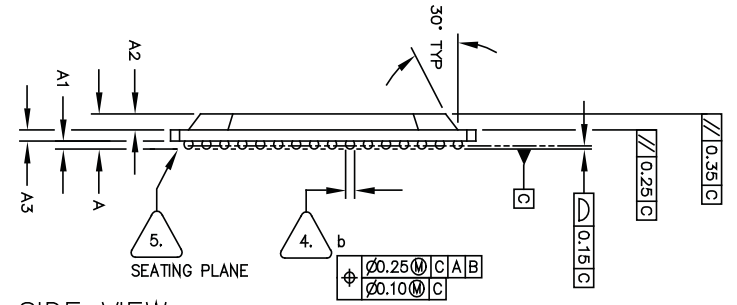

SIDE VIEW

5. PRIMARY DATUM C AND SEATING PLANE ARE DEFINED BY THE SPHERICAL CROWNS OF THE SOLDER BALLS.
4. DIMENSION IS MEASURED AT THE MAXIMUM SOLDER BALL DIAMETER PARALLEL TO PRIMARY DATUM C.
3. N IS NUMBER OF SOLDER BALLS
2. NOT TO SCALE.
1. ALL DIMENSIONS IN MM AND TOLERANCES CONFORM TO ASME Y14.5M-1994.

NOTES: UNLESS OTHERWISE SPECIFIED

© Microsemi Corporation 2006 All rights reserved.					Package Code	GK
ISSUE	1	2			Previous package codes	Package Outline for 256ball, 17x17mm, 1.0mm Pitch TEBGA-2
ACN	CDCA				N/A	
DATE	24Aug06					119347
APPRD.						

Information relating to products and services furnished herein by Microsemi Corporation or its subsidiaries (collectively "Microsemi") is believed to be reliable. However, Microsemi assumes no liability for errors that may appear in this publication, or for liability otherwise arising from the application or use of any such information, product or service or for any infringement of patents or other intellectual property rights owned by third parties which may result from such application or use. Neither the supply of such information or purchase of product or service conveys any license, either express or implied, under patents or other intellectual property rights owned by Microsemi or licensed from third parties by Microsemi, whatsoever. Purchasers of products are also hereby notified that the use of product in certain ways or in combination with Microsemi, or non-Microsemi furnished goods or services may infringe patents or other intellectual property rights owned by Microsemi.

This publication is issued to provide information only and (unless agreed by Microsemi in writing) may not be used, applied or reproduced for any purpose nor form part of any order or contract nor to be regarded as a representation relating to the products or services concerned. The products, their specifications, services and other information appearing in this publication are subject to change by Microsemi without notice. No warranty or guarantee express or implied is made regarding the capability, performance or suitability of any product or service. Information concerning possible methods of use is provided as a guide only and does not constitute any guarantee that such methods of use will be satisfactory in a specific piece of equipment. It is the user's responsibility to fully determine the performance and suitability of any equipment using such information and to ensure that any publication or data used is up to date and has not been superseded. Manufacturing does not necessarily include testing of all functions or parameters. These products are not suitable for use in any medical and other products whose failure to perform may result in significant injury or death to the user. All products and materials are sold and services provided subject to Microsemi's conditions of sale which are available on request.

**For more information about all Microsemi products  
visit our website at  
[www.microsemi.com](http://www.microsemi.com)**

TECHNICAL DOCUMENTATION – NOT FOR RESALE



**Microsemi Corporate Headquarters**  
One Enterprise, Aliso Viejo CA 92656 USA  
Within the USA: +1 (949) 380-6100  
Sales: +1 (949) 380-6136  
Fax: +1 (949) 215-4996

Microsemi Corporation (NASDAQ: MSCC) offers a comprehensive portfolio of semiconductor solutions for: aerospace, defense and security; enterprise and communications; and industrial and alternative energy markets. Products include high-performance, high-reliability analog and RF devices, mixed signal and RF integrated circuits, customizable SoCs, FPGAs, and complete subsystems. Microsemi is headquartered in Aliso Viejo, Calif. Learn more at [www.microsemi.com](http://www.microsemi.com).

© 2012 Microsemi Corporation. All rights reserved. Microsemi and the Microsemi logo are trademarks of Microsemi Corporation. All other trademarks and service marks are the property of their respective owners.



Компания «ЭлектроПласт» предлагает заключение долгосрочных отношений при поставках импортных электронных компонентов на взаимовыгодных условиях!

Наши преимущества:

- Оперативные поставки широкого спектра электронных компонентов отечественного и импортного производства напрямую от производителей и с крупнейших мировых складов;
- Поставка более 17-ти миллионов наименований электронных компонентов;
- Поставка сложных, дефицитных, либо снятых с производства позиций;
- Оперативные сроки поставки под заказ (от 5 рабочих дней);
- Экспресс доставка в любую точку России;
- Техническая поддержка проекта, помощь в подборе аналогов, поставка прототипов;
- Система менеджмента качества сертифицирована по Международному стандарту ISO 9001;
- Лицензия ФСБ на осуществление работ с использованием сведений, составляющих государственную тайну;
- Поставка специализированных компонентов (Xilinx, Altera, Analog Devices, Intersil, Interpoint, Microsemi, Aeroflex, Peregrine, Syfer, Eurofarad, Texas Instrument, Miteq, Cobham, E2V, MA-COM, Hittite, Mini-Circuits, General Dynamics и др.);

Помимо этого, одним из направлений компании «ЭлектроПласт» является направление «Источники питания». Мы предлагаем Вам помощь Конструкторского отдела:

- Подбор оптимального решения, техническое обоснование при выборе компонента;
- Подбор аналогов;
- Консультации по применению компонента;
- Поставка образцов и прототипов;
- Техническая поддержка проекта;
- Защита от снятия компонента с производства.



#### Как с нами связаться

**Телефон:** 8 (812) 309 58 32 (многоканальный)

**Факс:** 8 (812) 320-02-42

**Электронная почта:** [org@eplast1.ru](mailto:org@eplast1.ru)

**Адрес:** 198099, г. Санкт-Петербург, ул. Калинина, дом 2, корпус 4, литера А.