

Two-, Four-, & Eight-Way Isolated Power Dividers Wilkinson

Rev. V3

Features

- Excellent Amplitude and Phase Balance
- High Isolation between Output Ports
- Low VSWR, Small Size and Light Weight
- Octave and Multi-Octave Frequency Coverage
- Power: 10 Watts Input Maximum with Matched Terminations

Description and Applications

This series of two-way, in-phase stripline power dividers demonstrates excellent performance as well as small size and light weight. These octave and multi-octave power dividers have high isolation, low VSWR and excellent amplitude and phase balance.



Note: All dimensions are $\pm .020$, except mounting hole diameters ($\pm .005$) and mounting hole location ($\pm .010$).

Typical Performance Part No. 2089-6208-00



Two-Way Isolated Power Divider Specifications

Part No.	Frequency Range (GHz)	VSWR (max.)	Isolation dB (min.)	Insertion Loss dB (max.)	Output Unbalance		Maximum Input Power* (watts)	Size, Inches (mm)		Weight	
					Amp. (dB)	Phase (deg.)		A	B	oz.	g
2089-6201-00	1.0-2.0	1.25	20	0.25	0.2	4.0	2.0	2.0 (50.8)	0.5 (12.7)	1.5	43
2089-6202-00	2.0-4.0	1.35	20	0.25	0.2	4.0	2.0	2.0 (50.8)	0.5 (12.7)	1.5	43
2089-6203-00	4.0-8.0	1.35	20	0.3	0.2	6.0	2.0	1.38 (35)	0.4 (10.2)	1.2	35
2089-6204-00	8.0-12.4	1.60	20	0.4	0.25	6.0	2.0	1.38 (35)	0.4 (10.2)	1.2	35
2089-6205-00	12.4-18.0	1.70	17	0.6	0.25	6.0	3.0	1.38 (35)	0.4 (10.2)	1.2	35
2089-6206-00	0.5-2.0	1.30	20	0.4	0.2	4.0	4.0	2.8 (71.2)	1.4 (35.6)	2.0	57
2089-6207-00	2.0-8.0	1.50	18	0.4	0.25	8.0	4.0	2.25 (57.2)	0.5 (12.7)	1.3	37
2089-6208-00	2.0-18.0	1.60	17	1.0	0.25	8.0	10.0	2.25 (57.2)	0.5 (12.7)	1.3	37
2089-6209-00	4.0-18.0	1.60	17	0.6	0.25	8.0	4.0	1.63 (41.4)	0.5 (12.7)	1.3	37
2089-6210-00	7.0-18.0	1.70	17	0.6	0.25	8.0	3.0	1.38 (35)	0.4 (10.2)	1.2	35

* Maximum input power with output loads of VSWR $\leq 2.0:1$. Derate to 10% of listed value when arbitrarily terminated.

Two-, Four-, & Eight-Way Isolated Power Dividers Wilkinson

Rev. V3

Features

- Octave and Multi-Octave Frequency Coverage
- Low Insertion Loss
- Excellent Phase Balance
- High Isolation between Output Ports
- Low VSWR
- Power: 20 Watts Maximum

Description and Applications

These four-way in-phase power dividers combine excellent strip transmission line design techniques with small size and light weight and still achieve superb performance over wide multi-octave frequency ranges as well as over single octave bandwidths. These units may be used in reverse to combine in-phase signals applied to them. They can be custom designed to your particular application.



Note: All dimensions are $\pm .020$, except mounting hole diameters ($\pm .005$) and mounting hole location ($\pm .010$).

Typical Performance Part No. 2089-6408-00

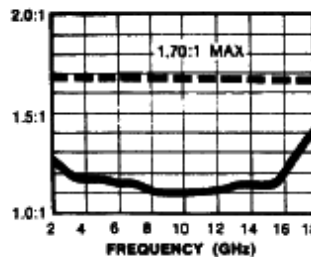
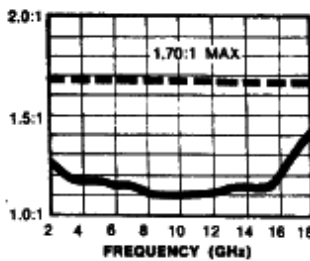

Four-Way Isolated Power Divider Specifications

Part No.	Frequency Range (GHz)	VSWR (max.)	Isolation dB (min.)	Insertion Loss dB (max.)	Output Unbalance		Maximum Input Power* (watts)	Size, Inches (mm)		Weight	
					Amp. (dB)	Phase (deg.)		A	B	oz.	g
2089-6401-00**	1.0-2.0	1.35	20	0.50	0.40	6	4.0	3.0 (76.2)	0.63 (15.9)	4.0	115
2089-6402-00	2.0-4.0	1.35	20	0.50	0.40	6	4.0	2.0 (50.8)		2.8	80
2089-6403-00	4.0-8.0	1.50	20	0.50	0.40	8	4.0	2.0 (50.8)		2.8	80
2089-6404-00	8.0-12.4	1.70	18	0.75	0.50	8	4.0	2.0 (50.8)		2.8	80
2089-6405-00	12.4-18.0	1.70	15	1.20	0.50	8	6.0	2.0 (50.8)		2.8	80
2089-6406-00	0.5-2.0	1.45	20	0.70	0.40	6	4.0	2.92 (74.2)		4.0	115
2089-6407-00	2.0-8.0	1.60	18	0.80	0.50	12	8.0	4.0 (102)		5.2	149
2089-6408-00	2.0-18.0	1.70	17	1.80	0.50	12	20.0	3.0 (76.2)		4.0	115
2089-6409-00	4.0-18.0	1.70	15	1.20	0.50	12	8.0	2.0 (50.8)		2.8	80
2089-6410-00	7.0-18.0	1.60	15	1.20	0.50	12	6.0	2.0 (50.8)		2.8	80

* Maximum input power with output loads of VSWR $\leq 2.0:1$. Derate to 10% of listed value when arbitrarily terminated.

** These units have four mounting holes symmetrically located as shown.

Two-, Four-, & Eight-Way Isolated Power Dividers Wilkinson

Rev. V3

Features

- Octave and Multi-Octave Frequency Coverage
- Excellent Amplitude and Phase Balance
- Low Insertion Loss
- Low VSWR

Description and Applications

These eight-way in-phase power dividers combine reliable strip transmission line design techniques with small size and light weight to achieve excellent performance over octave and multi-octave frequency ranges. They may also be used to combine in-phase signals applied at the outputs. SMA female connectors are standard.



All dimensions are $\pm .020$, except mounting hole diameters ($\pm .005$) and mounting hole location ($\pm .010$).

Typical Performance Part No. 2089-6803-00



Eight-Way Isolated Power Divider Specifications

Part No.	Frequency Range (GHz)	VSWR (max.)	Isolation dB (min.)	Insertion Loss dB (max.)	Output Unbalance		Maximum Input Power* (watts)	Size, Inches				Weight (NOM.) oz.
					Amp. (dB)	Phase (deg.)		A	B	H	I	
2089-6801-00	1.0-2.0	1.5:1	20	1.0	0.8	8	6.0	4.5	5.0	1.0	0.50	15
2089-6802-00	2.0-4.0	1.5:1	18	1.0	0.8	10	6.0	4.0	2.0	0.5	0.25	12
2089-6803-00	4.0-8.0	1.6:1	15	1.5	0.8	16	6.0	4.0	2.0	0.5	0.25	12
2089-6804-00	8.0-12.4	1.7:1	15	1.7	0.8	16	6.0	4.0	2.0	0.5	0.25	12
2089-6805-00	12.4-18.0	1.7:1	15	2.2	0.8	24	10.0	4.0	2.0	0.5	0.25	12
2089-6806-00	0.5-2.0	1.5:1	20	1.5	0.8	8	12.0	4.5	5.0	1.0	0.50	15
2089-6807-00	2.0-8.0	1.6:1	15	2.0	1.2	16	12.0	4.0	2.0	0.5	0.25	12
2089-6808-00	2.0-18.0	1.8:1	15	3.3	1.8	24	30.0	4.5	5.0	1.0	0.50	15
2089-6810-00	7.0-18.0	1.8:1	15	2.5	1.5	24	10.0	4.0	2.0	0.5	0.25	12

* Maximum input power with output loads of VSWR $\leq 2.0:1$. Derate to 10% of listed value when arbitrarily terminated.



Компания «ЭлектроПласт» предлагает заключение долгосрочных отношений при поставках импортных электронных компонентов на взаимовыгодных условиях!

Наши преимущества:

- Оперативные поставки широкого спектра электронных компонентов отечественного и импортного производства напрямую от производителей и с крупнейших мировых складов;
- Поставка более 17-ти миллионов наименований электронных компонентов;
- Поставка сложных, дефицитных, либо снятых с производства позиций;
- Оперативные сроки поставки под заказ (от 5 рабочих дней);
- Экспресс доставка в любую точку России;
- Техническая поддержка проекта, помощь в подборе аналогов, поставка прототипов;
- Система менеджмента качества сертифицирована по Международному стандарту ISO 9001;
- Лицензия ФСБ на осуществление работ с использованием сведений, составляющих государственную тайну;
- Поставка специализированных компонентов (Xilinx, Altera, Analog Devices, Intersil, Interpoint, Microsemi, Aeroflex, Peregrine, Syfer, Eurofarad, Texas Instrument, Miteq, Cobham, E2V, MA-COM, Hittite, Mini-Circuits, General Dynamics и др.);

Помимо этого, одним из направлений компании «ЭлектроПласт» является направление «Источники питания». Мы предлагаем Вам помощь Конструкторского отдела:

- Подбор оптимального решения, техническое обоснование при выборе компонента;
- Подбор аналогов;
- Консультации по применению компонента;
- Поставка образцов и прототипов;
- Техническая поддержка проекта;
- Защита от снятия компонента с производства.



Как с нами связаться

Телефон: 8 (812) 309 58 32 (многоканальный)

Факс: 8 (812) 320-02-42

Электронная почта: org@eplast1.ru

Адрес: 198099, г. Санкт-Петербург, ул. Калинина, дом 2, корпус 4, литера А.