

Dual, 3A, 2MHz Step-Down Regulator

General Description

The MAX8833 high-efficiency, dual step-down regulator is capable of delivering up to 3A at each output. The device operates from a 2.35V to 3.6V supply, and provides output voltages from 0.6V to $0.9 \times V_{IN}$, making it ideal for on-board point-of-load applications. Total output error is less than $\pm 1\%$ over load, line, and temperature.

The MAX8833 operates in PWM mode with a switching frequency ranging from 0.5MHz to 2MHz, set by an external resistor. It can also be synchronized to an external clock in the same frequency range. Two internal switching regulators operate 180° out-of-phase to reduce the input ripple current, and consequently reduce the required input capacitance. The high operating frequency minimizes the size of external components. High efficiency, internal dual-nMOS design keeps the board cool under heavy loads. The voltage-mode control architecture and the high-bandwidth ($> 15\text{MHz}$ typ) voltage-error amplifier allow a type III compensation scheme to be utilized to achieve fast response under both line and load transients, and also allow for ceramic output capacitors.

Programmable soft-start reduces input inrush current. Two enable inputs allow the turning on/off of each output individually, resulting in great flexibility for system-level designs. A reference input is provided to facilitate output-voltage tracking applications. The MAX8833 is available in a 32-pin thin QFN (5mm x 5mm) package with 0.8mm max height.

Applications

ASIC/CPU/DSP Power Supplies
DDR Power Supplies
Set-Top Box Power Supplies
Printer Power Supplies
Network Power Supplies

Pin Configuration appears at end of data sheet.

Features

- ◆ 35m Ω On-Resistance Internal MOSFETs
- ◆ Dual, 3A, PWM Step-Down Regulators
- ◆ Fully Protected Against Overcurrent, Short Circuit, and Overtemperature
- ◆ $\pm 1\%$ Output Accuracy over Load, Line, and Temperature
- ◆ Operates from 2.35V to 3.6V Supply
- ◆ REFIN on One Channel for Tracking or External Reference
- ◆ Integrated Boost Diodes
- ◆ Adjustable Output from 0.6V to $0.9 \times V_{IN}$
- ◆ Soft-Start Reduces Inrush Supply Current
- ◆ 0.5MHz to 2MHz Adjustable Switching, or FSYNC Input
- ◆ All-Ceramic-Capacitor Design
- ◆ 180° Out-of-Phase Operation Reduces Input Ripple Current
- ◆ Individual Enable Inputs and PWRGD Outputs
- ◆ Safe-Start into Prebiased Output
- ◆ Available in 5mm x 5mm Thin QFN Package
- ◆ Sink/Source Current in DDR Applications

Ordering Information

PART	TEMP RANGE	PIN-PACKAGE
MAX8833ETJ+	-40°C to +85°C	32 Thin QFN-EP*

+ Denotes a lead(Pb)-free/RoHS-compliant package.

*EP = Exposed pad.

Typical Operating Circuit

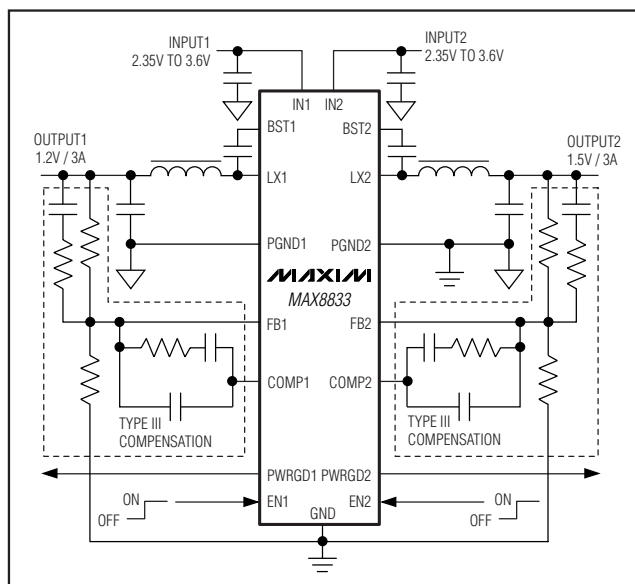

Dual, 3A, 2MHz Step-Down Regulator

ABSOLUTE MAXIMUM RATINGS

IN ₋ , LX ₋ , V _{DD} , V _{DL} , PWRGD ₋ to GND	-0.3V to +4.5V
V _{DD} , V _{DL} to IN ₋	-0.3V to +4.5V
EN ₋ , SS ₋ , COMP ₋ , FB ₋ , REFIN, FSYNC to GND	-0.3V to the lower of (V _{VDD} + 0.3V) and (V _{VDL} + 0.3V)
Continuous LX ₋ Current (Note 1)	5.5A _{RMS}
BST ₋ to LX ₋	-0.3V to +4.5V
PGND ₋ to GND	-0.3V to +0.3V

Continuous Power Dissipation (T _A = +70°C) 32-Pin Thin QFN (5mm x 5mm) (derate 34.5mW/°C above +70°C)	2758.6mW
Operating Ambient Temperature Range	-40°C to +85°C
Operating Junction Temperature Range	-40°C to +125°C
Storage Temperature Range	-65°C to +150°C
Lead Temperature (soldering, 10s)	+300°C
θ _{JC}	1.7°C/W

Note 1: LX₋ have internal clamp diodes to PGND₋ and IN₋. Applications that forward bias these diodes should take care not to exceed the IC's package power-dissipation limits.

Stresses beyond those listed under "Absolute Maximum Ratings" may cause permanent damage to the device. These are stress ratings only, and functional operation of the device at these or any other conditions beyond those indicated in the operational sections of the specifications is not implied. Exposure to absolute maximum rating conditions for extended periods may affect device reliability.

ELECTRICAL CHARACTERISTICS

(V_{IN₋} = V_{VDD} = V_{VDL} = 3.3V, V_{FB₋} = 0.5V, V_{SS₋} = V_{REFIN} = 600mV, PGND₋ = GND, R_{FSYNC} = 10kΩ, L = 0.47μH, C_{BST₋} = 0.1μF, C_{SS₋} = 0.022μF, PWRGD₋ not connected; T_A = -40°C to +85°C, typical values are at T_A = +25°C, unless otherwise noted.) (Note 2)

PARAMETER	CONDITIONS		MIN	TYP	MAX	UNITS
IN1, IN2, VDL, VDD						
IN ₋ , VDL, and V _{DD} Voltage Range	(Note 3)		2.35		3.60	V
IN ₋ Supply Current	1MHz switching, no load	V _{IN₋} = 2.5V		1.9	3.5	mA
		V _{IN₋} = 3.3V		2.8	5	
V _{DD} + VDL Supply Current	1MHz switching, V _{DD} = VDL	V _{VDD} = 2.5V		7.2		mA
		V _{VDD} = 3.3V		10	15	
Shutdown Supply Current (I _{IN1} + I _{IN2} + I _{VDD} + I _{VDL})	V _{IN₋} = V _{VDD} = V _{VDL} = V _{BST₋} - V _{LX₋} = 3.6V, V _{EN₋} = 0V	T _A = +25°C			11	μA
		T _A = +85°C		0.3		
IN ₋ , V _{DD} Undervoltage Lockout Threshold UVLO Monitors V _{DD} , IN1, and IN2	Rising			2.0	2.2	V
	Falling		1.8	1.9		
IN ₋ , V _{DD} Undervoltage Lockout Deglitch				2		μs
BST1, BST2						
Shutdown BST ₋ Current	V _{IN₋} = V _{VDD} = V _{VDL} = V _{BST₋} = 3.6V, V _{EN₋} = 0V, V _{LX₋} = 0 or 3.6V	T _A = +25°C			2	μA
		T _A = +85°C		0.02		
COMP1, COMP2						
COMP ₋ Clamp Voltage, High	V _{VDD} = V _{IN₋} = 2.3V to 3.6V, V _{FB₋} = 0.7V		1.80	2.00	2.25	V
COMP ₋ Slew Rate				1.40		V/μs
COMP ₋ Shutdown Resistance	From COMP ₋ to GND, V _{EN₋} = 0V			7	25	Ω
ERROR AMPLIFIER						
FB ₋ Regulation Voltage	V _{COMP₋} = 1V to 2V	V _{VDD} = V _{IN₋} = 2.5V to 3.3V	0.594	0.600	0.606	V
FB ₋ Regulation Voltage with External Reference	V _{COMP₋} = 1V to 2V	V _{VDD} = V _{IN₋} = 2.5V to 3.3V	0.594	0.600	0.606	V
Error Amplifier Common-Mode-Input Range			0		V _{VDD} - 1.6	V
Error Amplifier Maximum Output Current			1			mA
FB ₋ Input Bias Current	V _{FB₋} = 0.605V	T _A = +25°C		40	300	nA
		T _A = +85°C		37		

Dual, 3A, 2MHz Step-Down Regulator

MAX8833

ELECTRICAL CHARACTERISTICS (continued)

($V_{IN_} = V_{VDD} = V_{VDL} = 3.3V$, $V_{FB_} = 0.5V$, $V_{SS_} = V_{REFIN} = 600mV$, $PGND_ = GND$, $R_{FSYNC} = 10k\Omega$, $L = 0.47\mu H$, $C_{BST_} = 0.1\mu F$, $C_{SS_} = 0.022\mu F$, $PWRGD_$ not connected; $T_A = -40^\circ C$ to $+85^\circ C$, typical values are at $T_A = +25^\circ C$, unless otherwise noted.) (Note 2)

PARAMETER	CONDITIONS		MIN	TYP	MAX	UNITS
REFIN, SS2						
REFIN Input Bias Current	$V_{FB_} = 0.610V$	$T_A = +25^\circ C$		90	500	nA
		$T_A = +85^\circ C$		65		
REFIN Common-Mode Range	$V_{VDD} = 2.35V$ to $2.6V$		0		$V_{VDD} - 1.65$	V
	$V_{VDD} = 2.6V$ to $3.6V$		0		$V_{VDD} - 1.70$	
LX1, LX2 (All Pins Combined)						
LX_ On-Resistance, High	$I_{LX_} = -2A$	$V_{IN_} = V_{BST_} - V_{LX_} =$		40	55	m Ω
		$V_{IN_} = V_{BST_} - V_{LX_} =$		42		
LX_ On-Resistance, Low	$I_{LX_} = -2A$	$V_{IN_} = 3.3V$		35	54	m Ω
		$V_{IN_} = 2.5V$		37		
LX_ Current-Limit Threshold	High-side sourcing and freewheeling		4.6	5.5	6.4	A
LX_ Leakage Current	$V_{IN_} = 3.6V$, $V_{EN_} = 0V$	$V_{LX_} = 3.6V$	$T_A = +25^\circ C$		10	μA
			$T_A = +85^\circ C$		-0.1	
	$V_{LX_} = 0V$	$T_A = +25^\circ C$		-10		
		$T_A = +85^\circ C$		-0.1		
LX_ Switching Frequency	$R_{FSYNC} = 10k\Omega$		0.9	1.0	1.1	MHz
	$R_{FSYNC} = 4.75k\Omega$		1.80	2.0	2.2	
LX_ Minimum Off-Time				50		ns
LX_ Minimum On-Time				95		ns
LX_ Maximum Duty Cycle	$R_{FSYNC} = 10k\Omega$		90	95		%
Maximum LX_ Output Current			3			ARMS
EN1, EN2						
EN_ Logic-Low					0.7	V
EN_ Logic-High			1.7			V
EN_ Input Current	$V_{EN_} = 0$ or $3.6V$, $V_{VDD} = 3.6V$	$T_A = +25^\circ C$	-1		+1	μA
		$T_A = +85^\circ C$		0.01		
SS1, SS2						
SS_ Charging Current	$V_{SS_} = 300mV$		5	8	11	μA
REFIN, SS2						
Discharge Resistance	In shutdown or a fault condition			335		Ω
THERMAL SHUTDOWN						
Thermal-Shutdown Threshold (Independent Channels)				+165		$^\circ C$
Thermal-Shutdown Hysteresis				20		$^\circ C$

Dual, 3A, 2MHz Step-Down Regulator

ELECTRICAL CHARACTERISTICS (continued)

($V_{IN_} = V_{VDD} = V_{VDL} = 3.3V$, $V_{FB_} = 0.5V$, $V_{SS_} = V_{REFIN} = 600mV$, $PGND_ = GND$, $R_{FSYNC} = 10k\Omega$, $L = 0.47\mu H$, $C_{BST_} = 0.1\mu F$, $C_{SS_} = 0.022\mu F$, $PWRGD_$ not connected; $T_A = -40^\circ C$ to $+85^\circ C$, typical values are at $T_A = +25^\circ C$, unless otherwise noted.) (Note 2)

PARAMETER	CONDITIONS	MIN	TYP	MAX	UNITS
FSYNC					
FSYNC Capture Range		250		2500	kHz
FSYNC Input Threshold		1.3	1.5	1.7	V
FSYNC Output Voltage		0.975	1.0	1.025	V
Phase Shift from LX1 to LX2			180		Degrees
PWRGD1, PWRGD2					
PWRGD1 Threshold Voltage	V_{FB1} rising with respect to V_{REFIN} , and $V_{REFIN} > 540mV$ typ	88	90	92	%
PWRGD2 Threshold Voltage	V_{FB2} rising with respect to V_{SS2} , and $V_{SS2} > 540mV$ typ	88	90	92	%
PWRGD_ Hysteresis			2.6		%
PWRGD_ Falling Edge Deglitch		35	45	55	μs
PWRGD_ Output-Low Voltage	$I_{PWRGD_} = 4mA$		0.03	0.15	V
PWRGD_ Leakage Current	$V_{PWRGD_} = 3.6V$, $V_{FB_} = 0.9V$	$T_A = +25^\circ C$		1	μA
		$T_A = +85^\circ C$		0.01	

Note 2: All devices 100% production tested at $+25^\circ C$. Limits over temperature are guaranteed by design.

Note 3: V_{VDD} must equal V_{VDL} and be equal to or greater than $V_{IN_}$.

Typical Operating Characteristics

($V_{IN1} = V_{IN2} = 3.3V$. MAX8833, circuit of Figure 6, $T_A = +25^\circ C$, unless otherwise noted.)

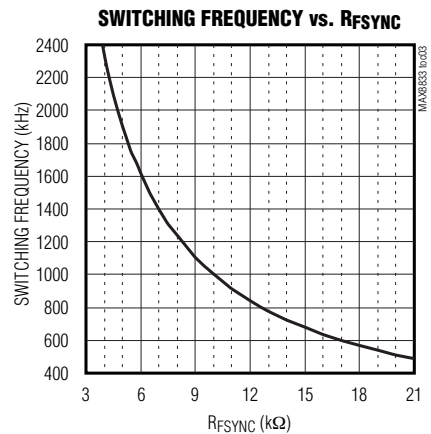
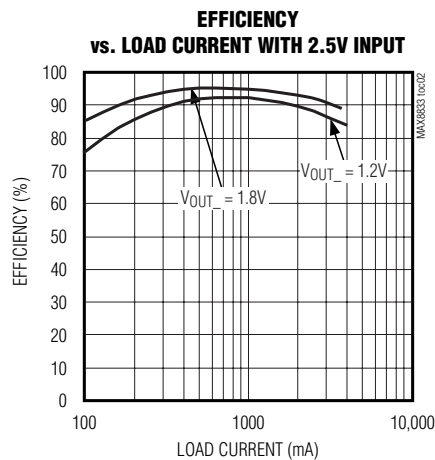
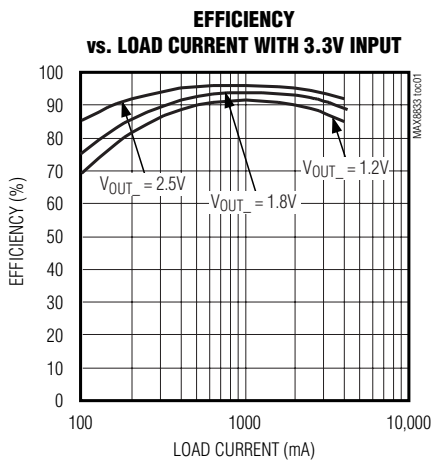

Dual, 3A, 2MHz Step-Down Regulator

MAX8833

Typical Operating Characteristics (continued)

($V_{IN1} = V_{IN2} = 3.3V$. MAX8833, circuit of Figure 6, $T_A = +25^\circ C$, unless otherwise noted.)

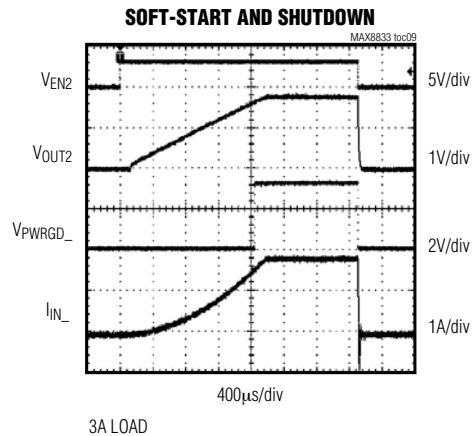
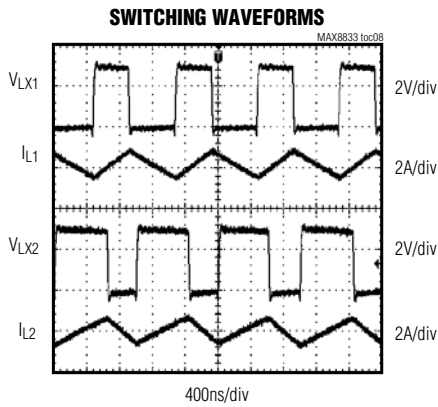
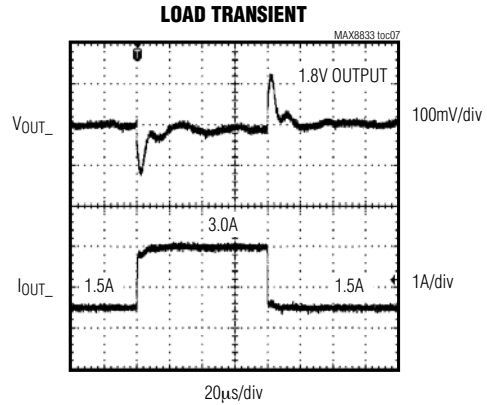
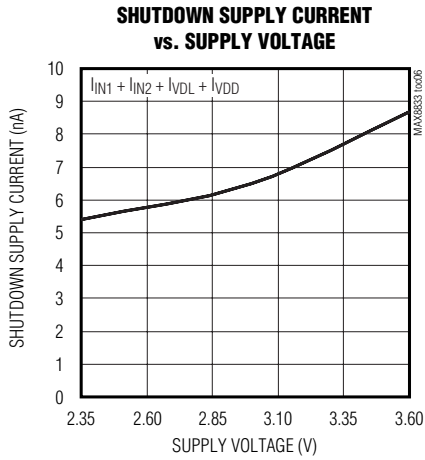
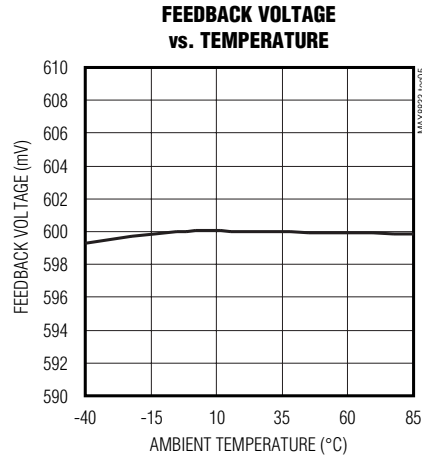
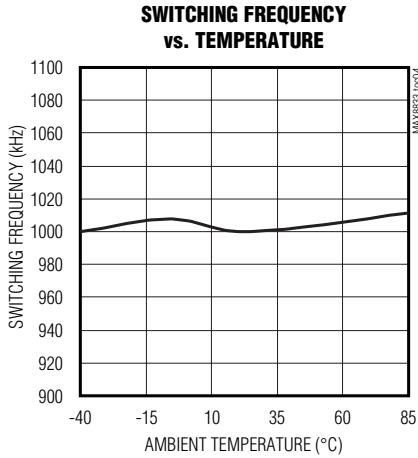

Dual, 3A, 2MHz Step-Down Regulator

Typical Operating Characteristics (continued)

($V_{IN1} = V_{IN2} = 3.3V$. MAX8833, circuit of Figure 6, $T_A = +25^\circ C$, unless otherwise noted.)

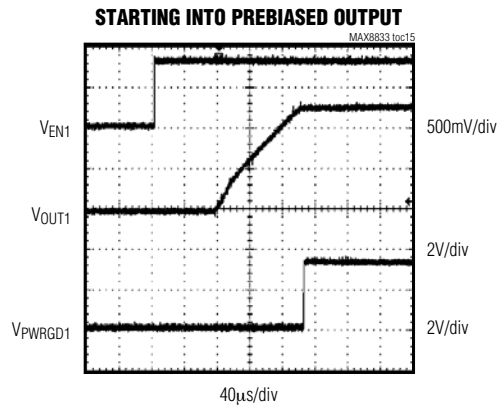
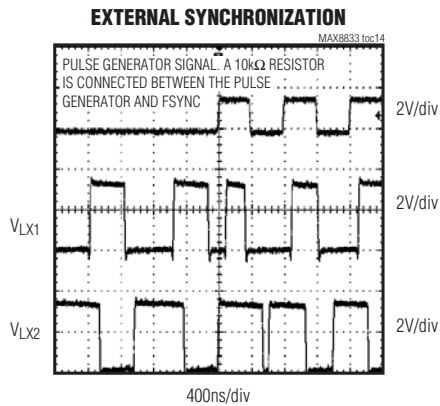
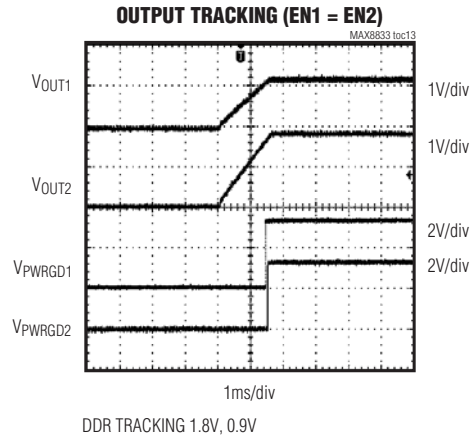
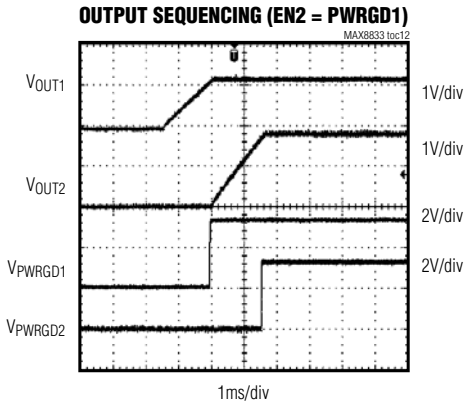
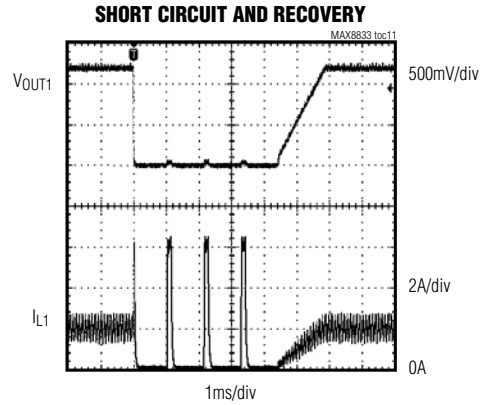
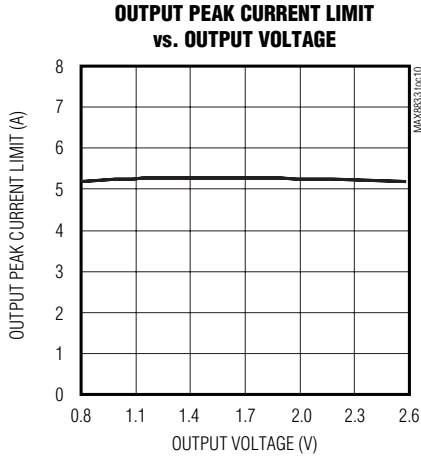

Dual, 3A, 2MHz Step-Down Regulator

Pin Description

MAX8833

PIN	NAME	FUNCTION
1	PWRGD1	Power-Good Open-Drain Output for Regulator 1. PWRGD1 is high impedance when $V_{REFIN} \geq 0.54V$ and $V_{FB1} \geq 0.9 \times V_{REFIN}$. PWRGD1 is low when $V_{REFIN} < 0.54V$, EN1 is low, V_{DD} or IN1 is below UVLO, the thermal shutdown is activated, or when $V_{FB1} < 0.9 \times V_{REFIN}$.
2	REFIN	External Reference Input for Regulator 1. Connect an external reference to REFIN, or connect REFIN to SS1 to use the internal reference. REFIN is discharged to GND through 335Ω when EN1 is low or regulator 1 is shut down due to a fault condition.
3	V_{DD}	Supply Voltage. Connect a 10Ω resistor from V_{DD} to VDL and connect a $0.1\mu F$ capacitor from V_{DD} to GND.
4	GND	Analog Ground. Connect GND to the analog ground plane. Connect the analog and power ground planes together at a single point near the IC.
5	N.C.	No Connection
6	VDL	Supply Voltage Input for Low-Side Gate Drive. Connect VDL to IN ₋ or the highest available supply voltage less than 3.6V. Connect a $1\mu F$ capacitor from VDL to the power ground plane.
7	FSYNC	Frequency Set and Synchronization. Connect a $4.75k\Omega$ to $20.5k\Omega$ resistor from FSYNC to GND to set switching frequency or drive with a 250kHz to 2.5MHz clock signal to synchronize switching. $R_{FSYNC} = (T - 0.05\mu s) \times (10k\Omega/0.95\mu s)$, where T is the oscillator period.
8	PWRGD2	Power-Good Open-Drain Output for Regulator 2. PWRGD2 is high impedance when $V_{SS2} \geq 0.54V$ and $V_{FB2} \geq 0.9 \times V_{SS2}$. PWRGD2 is low when $V_{SS2} < 0.54V$, EN2 is low, V_{DD} or IN2 is below UVLO, the thermal shutdown is activated, or when $V_{FB2} < 0.9 \times V_{SS2}$.
9	SS2	Soft-Start for Regulator 2. Connect a capacitor from SS2 to GND to set the soft-start time. See the <i>Setting the Soft-Start Time</i> section. SS2 is internally pulled low with 335Ω when EN2 is low or regulator 2 is in a fault condition.
10	FB2	Feedback Input for Regulator 2. Connect FB2 to the center of an external resistor-divider from the output to GND to set the output voltage from 0.6V to 90% of V_{IN2} . FB2 is high impedance when the IC is shut down.
11	COMP2	Compensation for Regulator 2. COMP2 is the output of the internal voltage-error amplifier. Connect external compensation network from COMP2 to FB2. See the <i>Compensation Design</i> section. COMP2 is internally pulled to GND when the output is shut down.
12	EN2	Enable Input for Regulator 2. Drive EN2 high to enable regulator 2, or drive low for shutdown. For always-on operation, connect EN2 to V_{DD} .
13, 14	IN2	Power-Supply Input for Regulator 2. The voltage range is 2.35V to 3.6V. Connect two $10\mu F$ and one $0.1\mu F$ ceramic capacitors from IN2 to PGND2.
15, 16, 17	PGND2	Power Ground for Regulator 2. Connect all PGND ₋ pins to the power ground plane. Connect the power ground and analog ground planes together at a single point near the IC.
18, 19	LX2	Inductor Connection for Regulator 2. Connect an inductor between LX2 and the regulator output. LX2 is high impedance when the IC is shut down.
20	BST2	Bootstrap Connection for Regulator 2. Connect a $0.1\mu F$ capacitor from BST2 to LX2. BST2 is the supply for the high-side gate drive. BST2 is charged from VDL with an internal pMOS switch. In shutdown, there is an internal diode junction from LX2 to BST2 and from VDL to BST2.
21	BST1	Bootstrap Connection for Regulator 1. Connect a $0.1\mu F$ capacitor from BST1 to LX1. BST1 is the supply for the high-side gate drive. BST1 is charged from VDL with an internal pMOS switch. In shutdown, there is an internal diode junction from LX1 to BST1 and from VDL to BST1.
22, 23	LX1	Inductor Connection for Regulator 1. Connect an inductor between LX1 and the regulator output. LX1 is high impedance when the IC is shut down.
24, 25, 26	PGND1	Power Ground for Regulator 1. Connect all PGND ₋ pins to the power ground plane. Connect the power ground and analog ground planes together at a single point near the IC.

Dual, 3A, 2MHz Step-Down Regulator

Pin Description (continued)

PIN	NAME	FUNCTION
27, 28	IN1	Power-Supply Input for Regulator 1. The voltage range is 2.35V to 3.6V. Connect two 10 μ F and one 0.1 μ F ceramic capacitors from IN1 to PGND1.
29	EN1	Enable Input for Regulator 1. Drive EN1 high to enable regulator 1, or low for shutdown. For always-on operation, connect EN1 to V _{DD} .
30	COMP1	Compensation for Regulator 1. COMP1 is the output of the internal voltage-error amplifier. Connect external compensation network from COMP1 to FB1. See the <i>Compensation Design</i> section. COMP1 is internally pulled to GND when the output is shut down.
31	FB1	Feedback Input for Regulator 1. Connect FB1 to the center of an external resistor-divider from the output to GND to set the output voltage from 0.6V to 90% of V _{IN1} . FB1 is high impedance when the IC is shut down.
32	SS1	Soft-Start for Regulator 1. Connect a capacitor from SS1 to GND to set the startup time. See the <i>Setting the Soft-Start Time</i> section. When E1 is disabled (pulled low), or regulator 1 is in shutdown mode due to a fault condition, SS1 is internally pulled low with 335 Ω resistor.
—	EP	Exposed Pad. Connect the exposed pad to the power ground plane.

Detailed Description

PWM Controller

The controller logic block is the central processor that determines the duty cycle of the high-side MOSFET under different line, load, and temperature conditions. Under normal operation, where the current-limit and temperature protection are not triggered, the control logic block takes the output from the PWM comparator and generates the driver signals for both high-side and low-side MOSFETs. It also contains the break-before-make logic and the timing for charging the bootstrap capacitors. The error signal from the voltage-error amplifier is compared with the ramp signal generated by the oscillator at the PWM comparator and, thus, the required PWM signal is produced. The high-side switch is turned on at the beginning of the oscillator cycle and turns off when the ramp voltage exceeds the V_{COMP_} signal or the current-limit threshold is exceeded. The low-side switch is then turned on for the remainder of the oscillator cycle. The two switching regulators operate at the same switching frequency with 180° phase shift to reduce the input-capacitor ripple current requirement. Figure 1 shows the MAX8833 functional diagram.

Current Limit

The MAX8833 provides both peak and valley current limits to achieve robust short-circuit protection. During the high-side MOSFET's on-time, if the drain-source current reaches the peak current-limit threshold (specified in the *Electrical Characteristics* table), the high-side MOSFET turns off and the low-side MOSFET turns on, allowing the current to ramp down. At the next clock, the high-side MOSFET is turned on only if the inductor current is below the valley current limit. Otherwise, the PWM

cycle is skipped to continue ramping down the inductor current. When the inductor current stays above the valley current limit for 12 μ s and the FB_{_} is below 0.7 x V_{REFIN}, the regulator enters hiccup mode. During hiccup mode, the SS_{_} capacitor is discharged to zero and the soft-start sequence begins after a predetermined time period.

Undervoltage Lockout (UVLO)

When the V_{DD} supply voltage drops below the falling undervoltage threshold (typically 1.9V), the MAX8833 enters its undervoltage lockout mode (UVLO). UVLO forces the device to a dormant state until the input voltage is high enough to allow the device to function reliably. In UVLO, LX_{_} nodes of both regulators are in the high-impedance state. PWRGD1 and PWRGD2 are forced low in UVLO. When V_{DD} rises above the rising undervoltage threshold (typically 2V), the IC powers up normally as described in the *Startup and Sequencing* section.

The UVLO circuitry also monitors the IN1 and IN2 supplies. When the IN_{_} voltage drops below the falling undervoltage threshold (typically 1.9V), the corresponding regulator shuts down, and corresponding PWRGD_{_} goes low. The regulator powers up when V_{IN_{_}} rises above the rising undervoltage threshold (typically 2V).

Power-Good Output (PWRGD_{_})

PWRGD1 and PWRGD2 are open-drain outputs that indicate when the corresponding output is in regulation.

PWRGD1 is high impedance when V_{REFIN} \geq 0.54V and V_{FB1} \geq 0.9 x V_{REFIN}. PWRGD1 is low when V_{REFIN} < 0.54V, EN1 is low, V_{VDD} or V_{IN1} is below V_{UVLO}, the thermal-overload protection is activated, or when V_{FB1} < 0.9 x V_{REFIN}.

Dual, 3A, 2MHz Step-Down Regulator

MAX8833

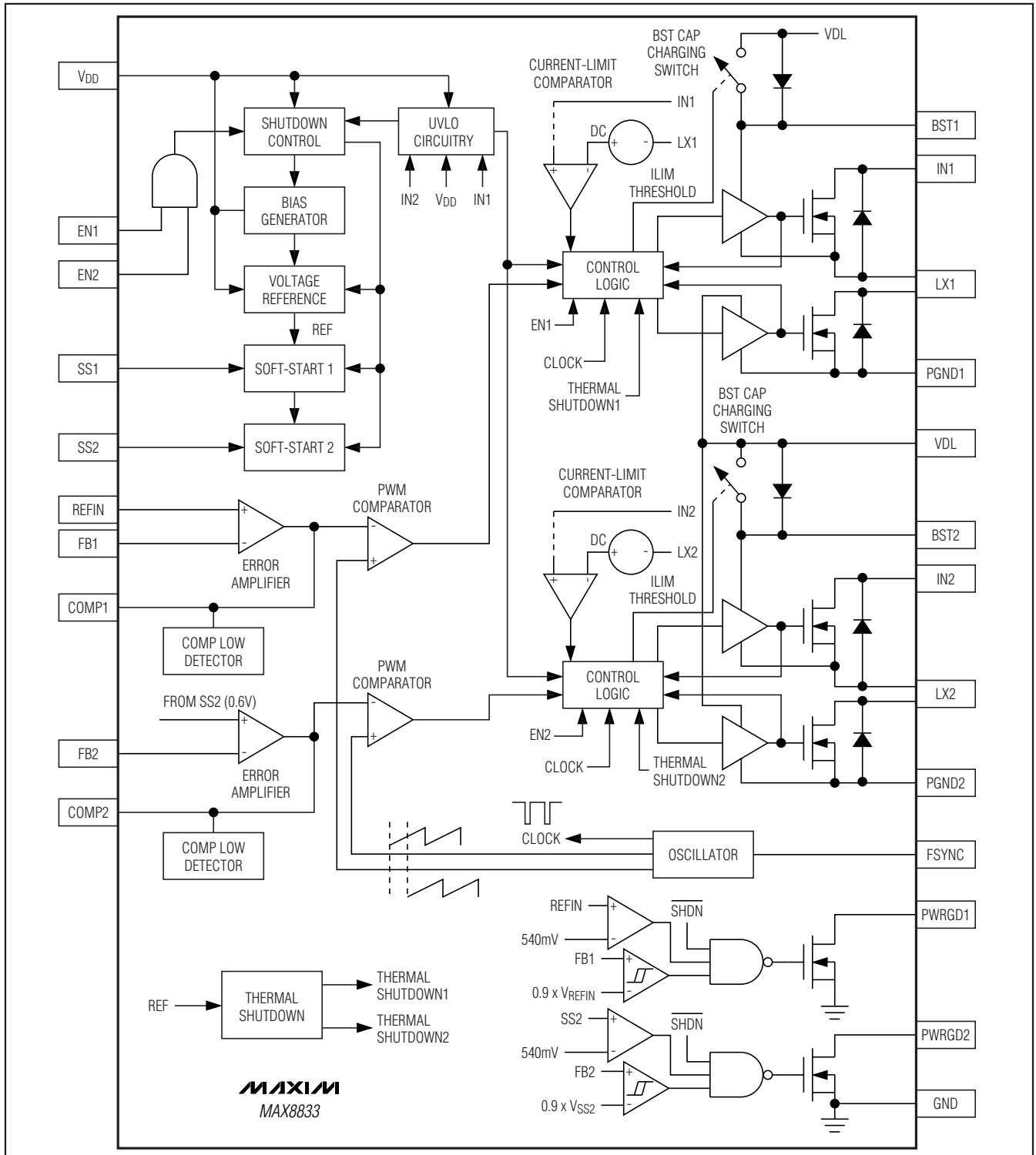

Figure 1. Functional Diagram

Dual, 3A, 2MHz Step-Down Regulator

The power-good, open-drain output for regulator 2 (PWRGD2) is high impedance when $V_{SS2} \geq 0.54V$ and $V_{FB2} \geq 0.9 \times V_{SS2}$. PWRGD2 is low when $V_{SS2} < 0.54V$, EN2 is low, V_{DD} or V_{IN2} is below V_{UVLO} , the thermal-overload protection is activated, or when $V_{FB2} < 0.9 \times V_{SS2}$.

External Reference Input (REFIN)

The MAX8833 has an external reference input. Connect an external reference between 0 and $V_{DD} - 1.6V$ to REFIN to set the FB1 regulation voltage. To use the internal 0.6V reference, connect REFIN to SS1. When the IC is shut down, REFIN is pulled to GND through 335Ω .

Startup and Sequencing

The MAX8833 features separate enable inputs (EN1 and EN2) for the two regulators. Driving EN_n high enables the corresponding regulator; driving EN_n low turns the regulator off. Driving both EN1 and EN2 low puts the IC in low-power shutdown mode, reducing the supply current typically to 30nA. The MAX8833 regulators power up when the following conditions are met (see Figure 2):

- EN_n is logic-high.
- V_{DD} is above the UVLO threshold.
- V_{IN_n} is above the UVLO threshold.
- The internal reference is powered.
- The IC is not in thermal overload ($T_J < +165^\circ C$).

Once these conditions are met, the MAX8833 begins soft-start. FB2 regulates to the voltage at SS2. During soft-start, the SS2 capacitor is charged with a constant $8\mu A$ current source so that its voltage ramps up for the

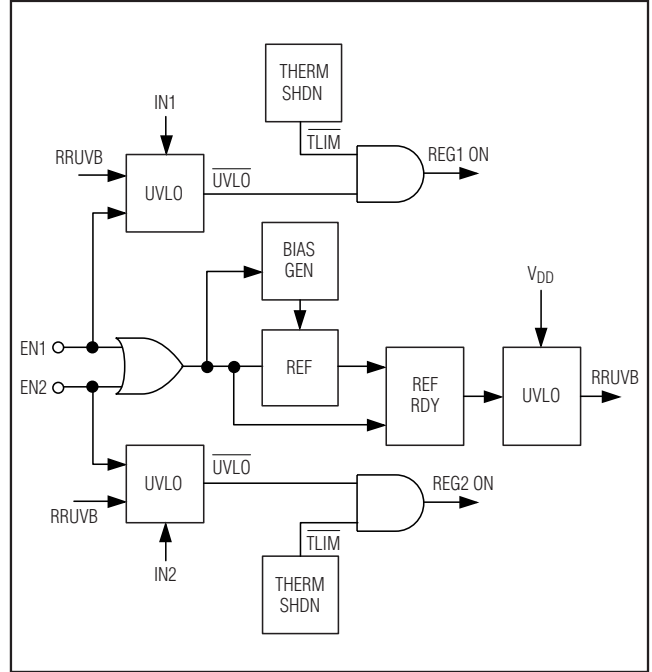

Figure 2. Startup Control Diagram

soft-start time. See the *Setting the Soft-Start Time* section to select the SS2 capacitor for the desired soft-start time. FB1 regulates to the voltage at REFIN. Connect REFIN to SS1 to use the internal reference with soft-start time set independently by the SS1 capacitor (see Figure 3a).

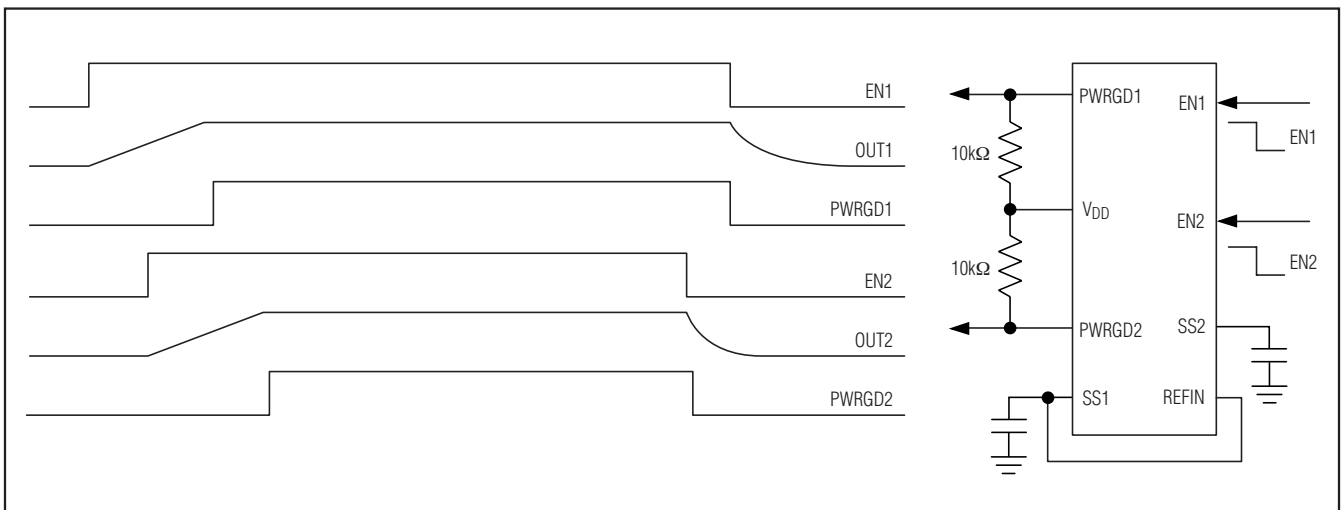

Figure 3a. Startup and Sequencing Options—Two Independent Output Startup and Shutdown Waveforms

Dual, 3A, 2MHz Step-Down Regulator

For ratiometric tracking applications, connect REFIN to the center of a voltage-divider from the output of regulator 2 to GND (see Figure 3b). In this application, the EN_ inputs are connected to each other and driven as a single enable input. Regulator 2 starts up with a normal soft-start (C_{SS2} sets the time), and regulator 1 output ratiometrically tracks the regulator 2 output voltage. The voltage-divider resistors set the V_{OUT1}/V_{OUT2} ratio (see

the *Setting the Output Voltage* section). In Figure 3b, V_{OUT1} regulates to half of V_{OUT2} . Note that a capacitance of 1000pF should be connected to SS1 for stability.

Figure 3c shows the output sequencing application using an external reference.

Sequencing is achieved by connecting EN2 to PWRGD1. In this mode, regulator 2 starts once regulator 1 reaches regulation.

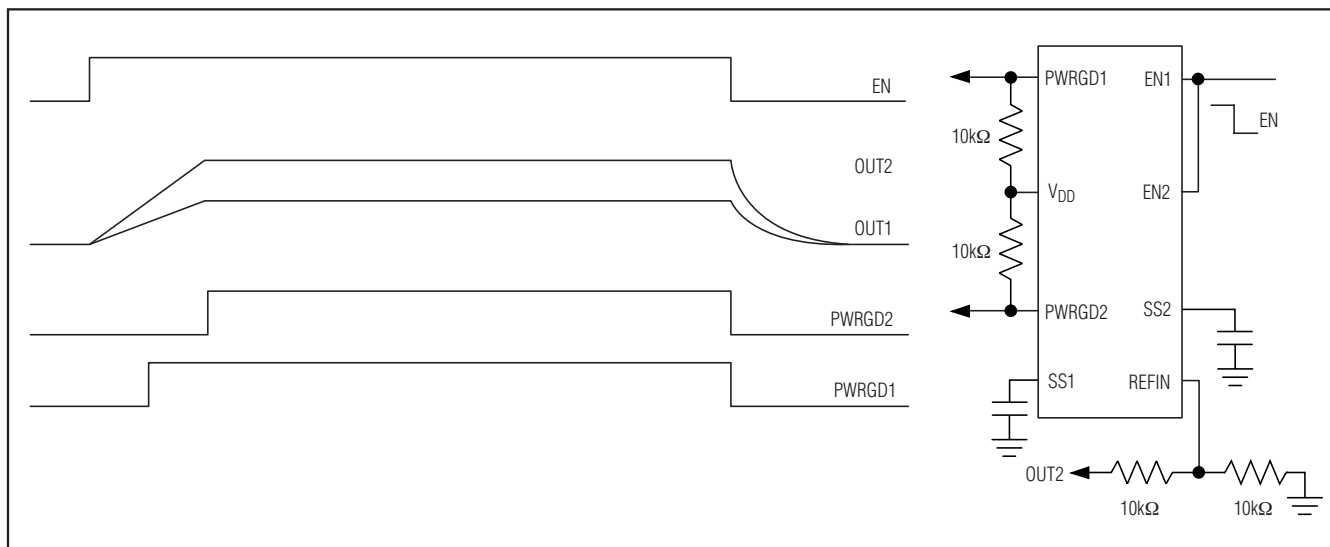

Figure 3b. Startup and Sequencing Options—Ratiometric Tracking Startup and Shutdown Waveforms V_{OUT1} Track V_{OUT2}

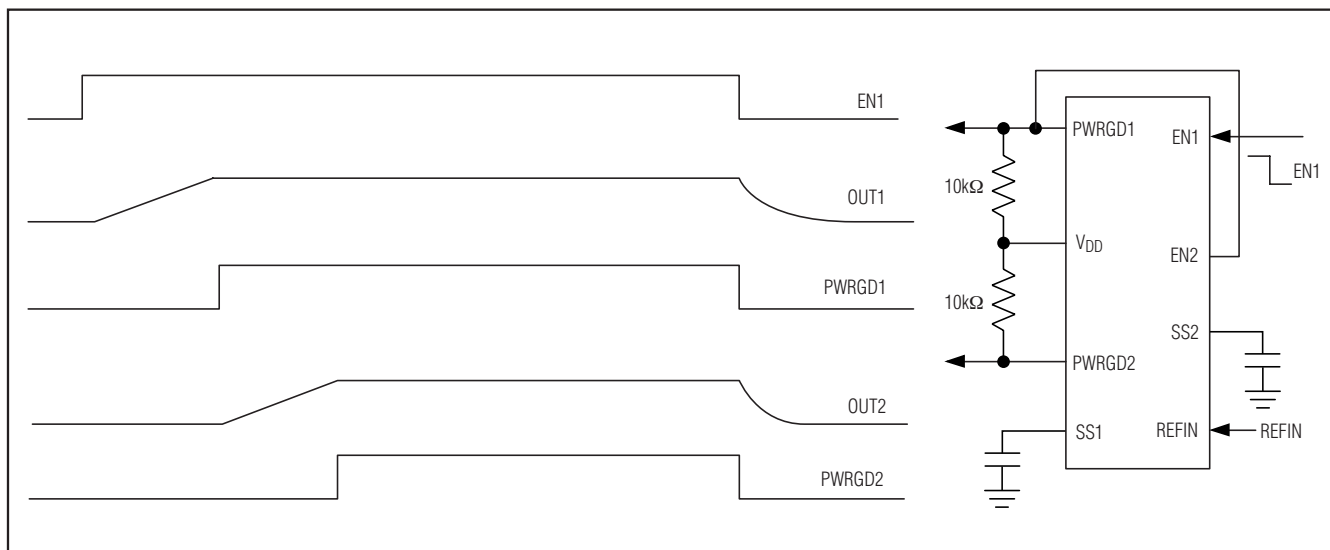

Figure 3c. Startup and Sequencing Options—Sequencing Startup and Shutdown Waveforms with External Reference

Dual, 3A, 2MHz Step-Down Regulator

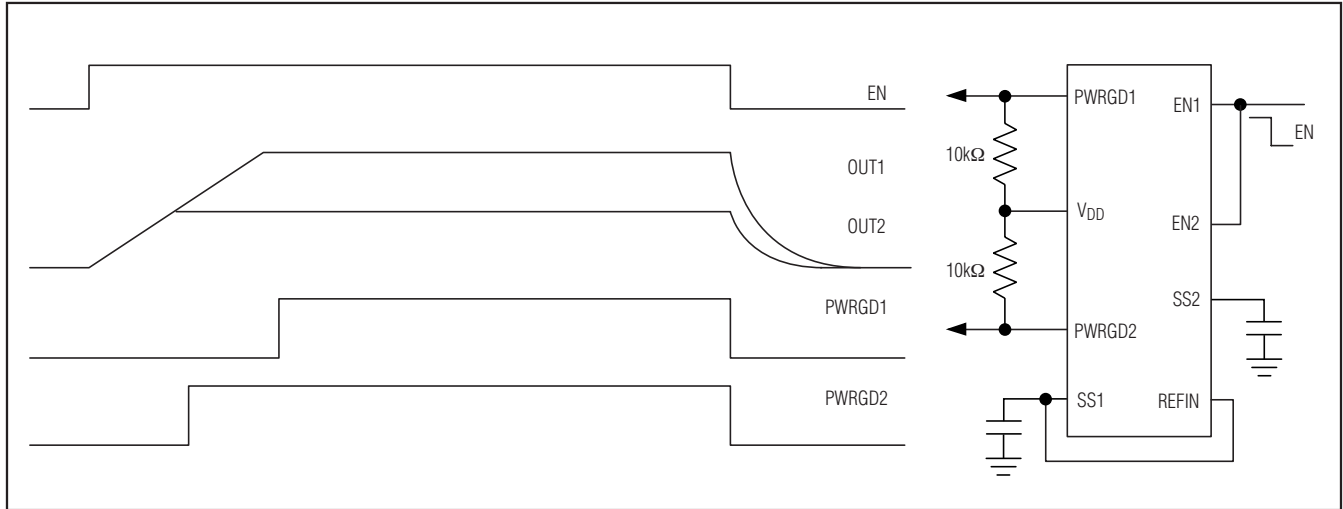

Figure 3d. Startup and Sequencing Options—Matching Startup Slopes of Output Voltages with Internal Reference

In Figure 3d, EN1 and EN2 are connected together and driven as a single input. Although both outputs begin ramping up at the same time, slope matching is achieved by selecting the SS_ capacitors. See the *Setting the Soft-Start Time* section for information on selecting the SS_ capacitors. In Figure 3d, the slope of the output voltages during soft-start is equal. This is achieved by setting the ratio of the soft-start capacitors equal to the ratio of the output voltages:

$$\frac{C_{SS1}}{C_{SS2}} = \frac{V_{OUT1}}{V_{OUT2}}$$

Synchronization (FSYNC)

The MAX8833 operates from 500kHz to 2MHz using either its internal oscillator, or an externally supplied clock. See the *Setting the Switching Frequency* section.

Thermal-Overload Protection

Thermal-overload protection limits the total power dissipation of the MAX8833. Internal thermal sensors monitor the junction temperature at each of the regulators. When the junction temperature exceeds +165°C, the corresponding regulator is shut down, allowing the IC to cool. The thermal sensor turns the regulator on after the junction temperature cools by +20°C. In a continuous thermal-overload condition, this results in a pulsed output.

Design Procedure

Setting the Output Voltage

The output voltages for regulator 1 (with REFIN connected to SS1) and regulator 2 are set with a resistor voltage-divider connected from the output to FB_ to GND as shown in Figure 4. Select a value for the resistor connected from output to FB_ (R4 in Figure 4) between 2kΩ and 10kΩ. Use the following equations to find the value for the resistor connected from FB_ to GND (R6 in Figure 4):

$$R6 = \frac{0.6}{(V_{OUT_} - 0.6)} \times R4$$

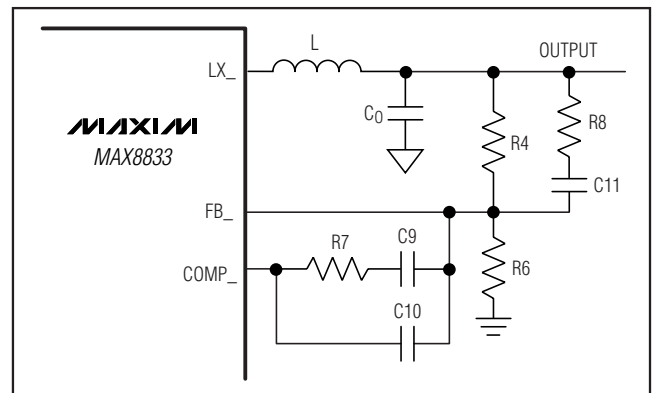

Figure 4. Type III Compensation Network

Dual, 3A, 2MHz Step-Down Regulator

In DDR tracking applications such as Figure 7, the FB1 regulation voltage tracks the voltage at REFIN. In Figure 7, the output of regulator 1 tracks V_{OUT2} , and the ratio of the output voltages is set as follows:

$$\frac{V_{OUT1}}{V_{OUT2}} = \frac{R19}{R1 + R19}$$

Setting the Switching Frequency

The MAX8833 has an adjustable internal oscillator that can be set to any frequency from 500kHz to 2MHz. To set the switching frequency, connect a resistor from FSYNC to GND. Calculate the resistor value from the following equation:

$$R_{FSYNC} = \left(\frac{1}{f_s} - 50\text{ns} \right) \left(\frac{10\text{k}\Omega}{950\text{ns}} \right)$$

The MAX8833 can also be synchronized to an external clock from 500kHz to 2MHz by connecting the clock signal to FSYNC through a 10k Ω isolation resistor. The external sync frequency must be higher than the frequency that would be produced by R_{FSYNC} . The two regulators switch at the same frequency as the FSYNC clock, and are 180° out-of-phase with each other. The external clock duty cycle may range between 10% and 90% to ensure 180° out-of-phase operation.

Setting the Soft-Start Time

The two step-down regulators have independent adjustable soft-start. Capacitors from SS₋ to GND are charged from a constant 8 μ A (typ) current source to the feedback-regulation voltage. The value of the soft-start capacitors is calculated from the desired soft-start time as follows:

$$C_{SS_} = t_{SS} \times \left(\frac{8\mu\text{A}}{0.6\text{V}} \right)$$

Inductor Selection

There are several parameters that must be examined when determining which inductor to use: maximum input voltage, output voltage, load current, switching frequency, and LIR. LIR is the ratio of inductor current ripple to DC load current. A higher LIR value allows for a smaller inductor, but results in higher losses and higher output ripple. On the other hand, higher inductor values increase efficiency, but eventually resistive losses due to extra turns of wire exceed the benefit gained from lower AC current levels. A good compromise between size and efficiency is a 30% LIR. For applications in which size and transient response are impor-

tant, an LIR of around 40% to 50% is recommended. Once all the parameters are chosen, the inductor value is determined as follows:

$$L = \frac{V_{OUT} \times (V_{IN} - V_{OUT})}{f_s \times V_{IN} \times \text{LIR} \times I_{OUT(\text{MAX})}}$$

where f_s is the switching frequency. Choose a standard value close to the calculated value. The exact inductor value is not critical and can be adjusted to make trade-offs among size, cost, and efficiency. Find a low-loss inductor with the lowest possible DC resistance that fits the allotted dimensions. The peak inductor current is determined as:

$$I_{PEAK} = \left(1 + \frac{\text{LIR}}{2} \right) \times I_{OUT(\text{MAX})}$$

I_{PEAK} must not exceed the chosen inductor's saturation current rating or the minimum current-limit specification for the MAX8833.

Input-Capacitor Selection

The input capacitor for each regulator serves to reduce the current peaks drawn from the input power supply and reduces switching noise in the IC. The total input capacitance for each rail must be equal to or greater than the value given by the following equation to keep the input-voltage ripple within specifications and minimize the high-frequency ripple current being fed back to the input source:

$$C_{IN_MIN_} = \frac{D_ \times I_{OUT_}}{f_{SW} \times V_{IN_RIPPLE_}}$$

where $D_$ is the quiescent duty cycle ($V_{OUT_}/V_{IN_}$); f_{SW} is the switching frequency; and $V_{IN_RIPPLE_}$ is the peak-to-peak input-voltage ripple, which should be less than 2% of the minimum DC input voltage.

The impedance of the input capacitor at the switching frequency should be less than that of the input source so high-frequency switching currents do not pass through the input source but are instead shunted through the input capacitor. High source impedance requires high-input capacitance. The input capacitor must meet the ripple current requirement imposed by the switching currents. The RMS input ripple current, $I_{RIPPLE_}$, is given by:

$$I_{RIPPLE_} = I_{OUT_} \times \sqrt{D_ \times (1 - D_)}$$

Dual, 3A, 2MHz Step-Down Regulator

Output-Capacitor Selection

The key selection parameters for the output capacitor are capacitance, ESR, ESL, and voltage-rating requirements. These affect the overall stability, output ripple voltage, and transient response of the DC-DC converter. The output ripple occurs due to variations in the charge stored in the output capacitor, the voltage drop due to the capacitor's ESR, and the voltage drop due to the capacitor's ESL. Calculate the output-voltage ripple due to the output capacitance, ESR, and ESL as:

$$V_{\text{RIPPLE}} = V_{\text{RIPPLE}(C)} + V_{\text{RIPPLE}(ESR)} + V_{\text{RIPPLE}(ESL)}$$

where the output ripple due to output capacitance, ESR, and ESL is:

$$V_{\text{RIPPLE}(C)} = \frac{I_{\text{P-P}}}{8 \times C_{\text{OUT}} \times f_{\text{S}}}$$

$$V_{\text{RIPPLE}(ESR)} = I_{\text{P-P}} \times \text{ESR}$$

$$V_{\text{RIPPLE}(ESL)} = \frac{I_{\text{P-P}}}{t_{\text{ON}}} \times \text{ESL}$$

or:

$$V_{\text{RIPPLE}(ESL)} = \frac{I_{\text{P-P}}}{t_{\text{OFF}}} \times \text{ESL}$$

whichever is greater.

It should be noted that the above ripple voltage components add vectorially rather than algebraically, thus making V_{RIPPLE} a conservative estimate.

The peak inductor current ($I_{\text{P-P}}$) is:

$$I_{\text{P-P}} = \frac{V_{\text{IN}} - V_{\text{OUT}}}{f_{\text{S}} \times L} \times \frac{V_{\text{OUT}}}{V_{\text{IN}}}$$

Use these equations for initial capacitor selection. Determine final values by testing a prototype or an evaluation circuit. A smaller ripple current results in less output-voltage ripple. Since the inductor ripple current is a function of the inductor value, the output-voltage ripple decreases with larger inductance. Use ceramic capacitors for low ESR and low ESL at the switching frequency of the converter. The low ESL of ceramic capacitors makes ripple voltages due to ESL negligible.

Load-transient response depends on the selected output capacitance. During a load transient, the output instantly changes by $\text{ESR} \times \Delta I_{\text{LOAD}}$. Before the controller can respond, the output deviates further, depending on the inductor and output capacitor values.

After a short time, the controller responds by regulating the output voltage back to its predetermined value. The controller response time depends on the closed-loop bandwidth. A higher bandwidth yields a faster response time, preventing the output from deviating further from its regulating value. See the *Compensation Design* and *Safe-Starting into a Prebiased Output* sections for more details.

Compensation Design

The power-stage transfer function consists of one double pole and one zero. The double pole is introduced by the output filtering inductor, L , and the output filtering capacitor, C_{O} . The ESR of the output filtering capacitor determines the zero. The double pole and zero frequencies are given as follows:

$$f_{\text{P1_LC}} = f_{\text{P2_LC}} = \frac{1}{2\pi \times \sqrt{L \times C_{\text{O}} \times \left(\frac{R_{\text{O}} + \text{ESR}}{R_{\text{O}} + R_{\text{L}}} \right)}}$$

$$f_{\text{Z_ESR}} = \frac{1}{2\pi \times \text{ESR} \times C_{\text{O}}}$$

where R_{L} is equal to the sum of the output inductor's DC resistance and the internal switch resistance, $R_{\text{DS(ON)}}$. A typical value for $R_{\text{DS(ON)}}$ is $35\text{m}\Omega$. R_{O} is the output load resistance, which is equal to the rated output voltage divided by the rated output current. ESR is the total ESR of the output-filtering capacitor. If there is more than one output capacitor of the same type in parallel, the value of the ESR in the above equation is equal to that of the ESR of a single-output capacitor divided by the total number of output capacitors.

The high-switching-frequency range of the MAX8833 allows the use of ceramic output capacitors. Since the ESR of ceramic capacitors is typically very low, the frequency of the associated transfer-function zero is higher than the unity-gain crossover frequency, f_{C} , and the zero cannot be used to compensate for the double pole created by the output filtering inductor and capacitor. The double pole produces a gain drop of 40dB and a phase shift of 180° per decade. The error amplifier must compensate for this gain drop and phase shift to achieve a stable high-bandwidth closed-loop system. Therefore, use type III compensation as shown in Figure 4. Type III compensation possesses three poles and two zeros with the first pole, $f_{\text{P1_EA}}$, located at 0Hz (DC). Locations of other poles and zeros of type III compensation are given by:

$$f_{\text{Z1_EA}} = \frac{1}{2\pi \times R7 \times C9}$$

Dual, 3A, 2MHz Step-Down Regulator

$$f_{z2_EA} = \frac{1}{2\pi \times R4 \times C11}$$

$$f_{p2_EA} = \frac{1}{2\pi \times R7 \times C10}$$

$$f_{p3_EA} = \frac{1}{2\pi \times R8 \times C11}$$

$$C9 = \frac{2.5 \times V_{IN}}{2\pi \times f_C \times R4 \times \left(1 + \frac{R_L}{R_O}\right)}$$

where V_{IN} is the input voltage in volts, f_C is the crossover frequency in Hertz, $R4$ is the upper feedback resistor (in ohms), R_L is the sum of the inductor resistance and the internal switch on-resistance, and R_O is the output load resistance (V_{OUT}/I_{OUT}).

Due to the underdamped nature of the output LC double pole, set the two zero frequencies of the type III compensation less than the LC double-pole frequency to provide adequate phase boost. Set the two zero frequencies to 80% of the LC double-pole frequency. Hence:

$$R7 = \frac{1}{0.8 \times C9} \times \sqrt{\frac{L \times C_O \times (R_O + ESR)}{R_L + R_O}}$$

$$C11 = \frac{1}{0.8 \times R4} \times \sqrt{\frac{L \times C_O \times (R_O + ESR)}{R_L + R_O}}$$

These equations are based on the assumptions that $C9 \gg C10$, and $R4 \gg R8$, which are true in most applications. Placement of these poles and zeros is determined by the frequencies of the double pole and ESR zero of the power stage transfer function. It is also a function of the desired closed-loop bandwidth. Figure 5 shows the pole zero cancellations in the type III compensation design.

The following section outlines the step-by-step design procedure to calculate the required compensation components. Begin by setting the desired output voltage as described in the *Setting the Output Voltage* section.

The crossover frequency f_C (or closed-loop, unity-gain bandwidth of the regulator) should be between 10% and 20% of the switching frequency, f_S . A higher crossover frequency results in a faster transient response. Too high of a crossover frequency can result in instability. Once f_C is chosen, calculate $C9$ (in farads) from the following equation:

Set the third compensation pole, f_{p3_EA} , at f_{z_ESR} , which yields:

$$R8 = \frac{C_O \times ESR}{C11}$$

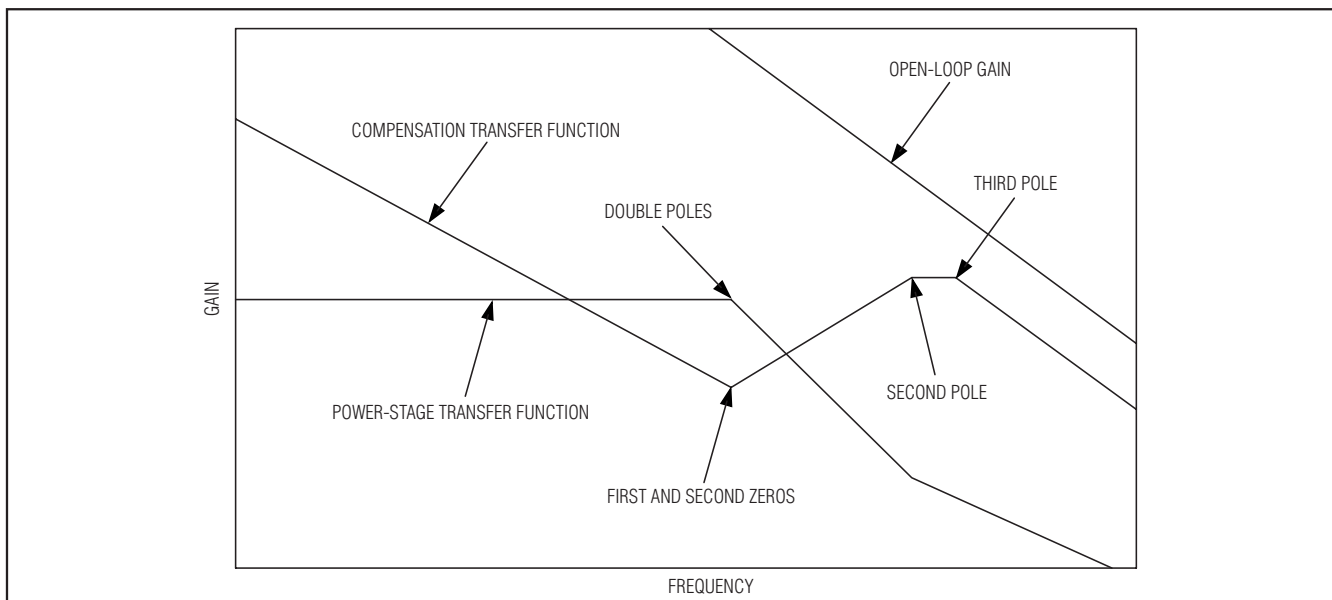

Figure 5. Pole Zero Cancellations in Compensation Design

Dual, 3A, 2MHz Step-Down Regulator

Set the second compensation pole at 1/2 the switching frequency. Calculate C10 as follows:

$$C_{10} = \frac{1}{\pi \times R_7 \times f_S}$$

The recommended range for R4 is 2kΩ to 10kΩ. Note that the loop compensation remains unchanged if only R6's resistance is altered to set different outputs.

Safe-Starting into a Prebiased Output

The MAX8833 is capable of safe-starting up into a pre-biased output without discharging the output capacitor. This type of operation is also termed monotonic startup. However, in order to avoid output voltage glitches during safe-start it should be ensured that the inductor current is in continuous conduction mode during the end of the soft-start period, this is done by satisfying the following equation:

$$C_O \times \frac{V_O}{t_{SS}} \geq \frac{I_{P-P}}{2}$$

where C_O is the output capacitor, V_O is the output voltage, t_{SS} is the soft-start time set by the soft-start capacitor C_{SS} , and I_{P-P} is the peak inductor ripple current (as defined in the *Output-Capacitor Selection* section). Depending on the application, one of these parameters may drive the selection of the others. See Starting into Prebiased Output waveforms in the *Typical Operating Characteristics* section for an example selection of the above parameters.

Applications Informations

PCB Layout Guidelines

Careful PCB layout is critical to achieve low switching losses and clean, stable operation. The switching power stage requires particular attention. It is highly recommended to duplicate the MAX8833 layout for optimum performance. If deviation is necessary, follow these guidelines for a good PCB layout:

- A multilayer PCB is recommended. Use inner-layer ground (and power) planes to minimize noise coupling.
- Place the input ceramic decoupling capacitor directly across and as close as possible to IN_ and PGND_. This is to help contain the high switching currents within a small loop.
- Connect IN_ and PGND_ separately to large copper areas to help cool the IC and further improve efficiency and long-term reliability.
- Connect input, output, and VDL capacitors to the power ground plane (PGND_).
- Keep the path of switching currents short and minimize the loop area formed by LX_, the output capacitor(s), and the input capacitor(s).
- Place the IC decoupling capacitors as close as possible to the IC pins, connecting all other ground-terminated capacitors, resistors, and passive components to the reference or analog ground plane (GND).
- Separate the power and analog ground planes, using a single-point common connection point (typically, at the C_{IN_} cathode).
- Connect the exposed pad to the analog ground plane, allowing sufficient copper area to help cool the device. If the exposed pad is used as a common PGND_-to-GND connection point, avoid running high current through the exposed pad by using separate vias to connect the PGND_ pins to the power ground plane rather than connecting them to the exposed pad on the top layer.
- Use caution when routing feedback and compensation node traces; avoid routing near high dV/dt nodes (LX_) and high-current paths. Place the feedback and compensation components as close as possible to the IC pins.
- Reference the MAX8833 Evaluation Kit for an example layout.

Dual, 3A, 2MHz Step-Down Regulator

MAX8833

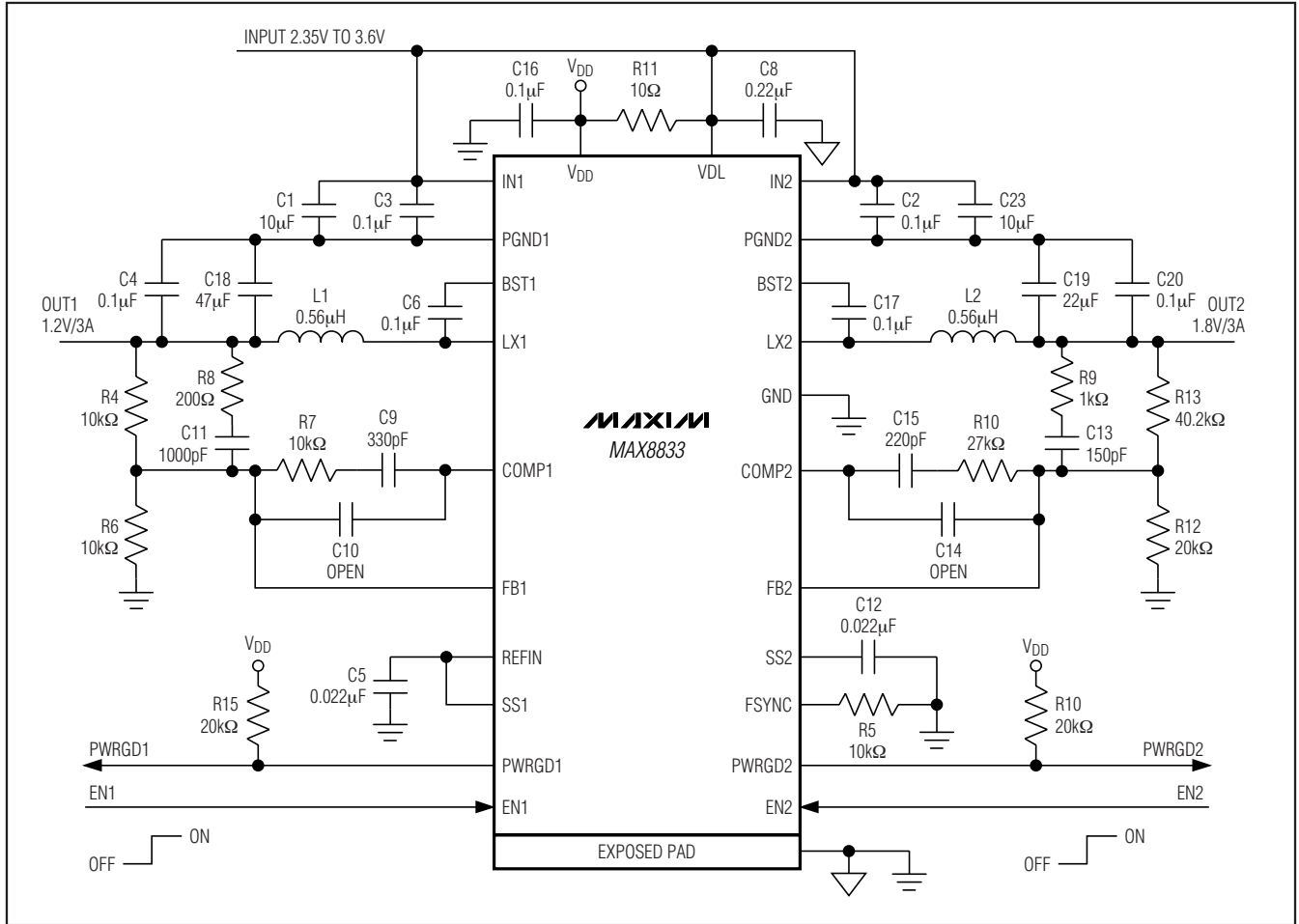

Figure 6. 1MHz Typical Application Circuit

Dual, 3A, 2MHz Step-Down Regulator

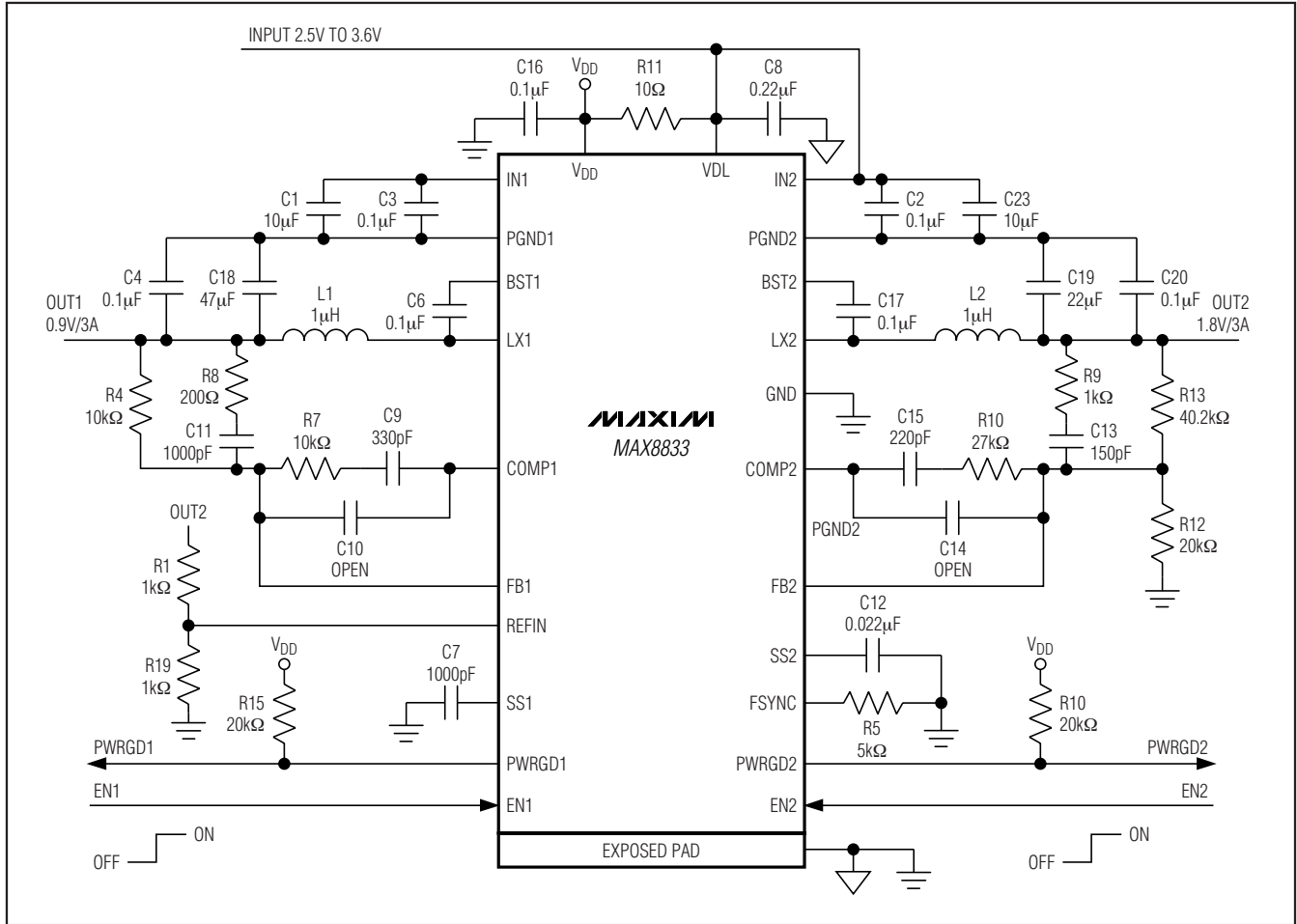
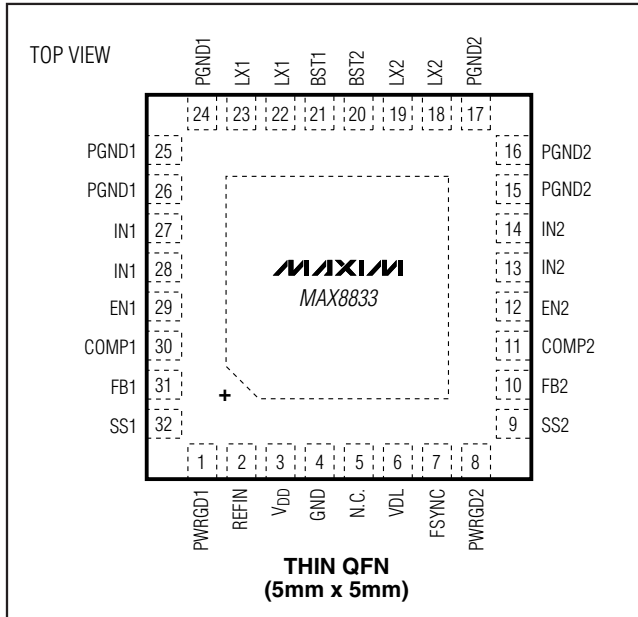

Figure 7. Tracking DDR Application Circuit

Dual, 3A, 2MHz Step-Down Regulator

MAX8833

Pin Configuration



Chip Information

PROCESS: BiCMOS

Package Information

For the latest package outline information and land patterns, go to www.maxim-ic.com/packages. Note that a "+", "#", or "-" in the package code indicates RoHS status only. Package drawings may show a different suffix character, but the drawing pertains to the package regardless of RoHS status.

PACKAGE TYPE	PACKAGE CODE	DOCUMENT NO.
32 TQFN	T3255-4	21-0140

Dual, 3A, 2MHz Step-Down Regulator

Revision History

REVISION NUMBER	REVISION DATE	DESCRIPTION	PAGES CHANGED
0	8/07	Initial release	—
1	6/08	Revised <i>Features</i> section and corrected Figure 6.	1, 17
2	4/09	Revised <i>Features</i> , <i>Typical Operating Characteristics</i> , and <i>Output-Capacitor Selection</i> sections. Added the <i>Safe-Starting into a Prebiased Output</i> section.	1, 6, 14, 16

Maxim cannot assume responsibility for use of any circuitry other than circuitry entirely embodied in a Maxim product. No circuit patent licenses are implied. Maxim reserves the right to change the circuitry and specifications without notice at any time.

20 _____ **Maxim Integrated Products, 120 San Gabriel Drive, Sunnyvale, CA 94086 408-737-7600**



Компания «ЭлектроПласт» предлагает заключение долгосрочных отношений при поставках импортных электронных компонентов на взаимовыгодных условиях!

Наши преимущества:

- Оперативные поставки широкого спектра электронных компонентов отечественного и импортного производства напрямую от производителей и с крупнейших мировых складов;
- Поставка более 17-ти миллионов наименований электронных компонентов;
- Поставка сложных, дефицитных, либо снятых с производства позиций;
- Оперативные сроки поставки под заказ (от 5 рабочих дней);
- Экспресс доставка в любую точку России;
- Техническая поддержка проекта, помощь в подборе аналогов, поставка прототипов;
- Система менеджмента качества сертифицирована по Международному стандарту ISO 9001;
- Лицензия ФСБ на осуществление работ с использованием сведений, составляющих государственную тайну;
- Поставка специализированных компонентов (Xilinx, Altera, Analog Devices, Intersil, Interpoint, Microsemi, Aeroflex, Peregrine, Syfer, Eurofarad, Texas Instrument, Miteq, Cobham, E2V, MA-COM, Hittite, Mini-Circuits, General Dynamics и др.);

Помимо этого, одним из направлений компании «ЭлектроПласт» является направление «Источники питания». Мы предлагаем Вам помощь Конструкторского отдела:

- Подбор оптимального решения, техническое обоснование при выборе компонента;
- Подбор аналогов;
- Консультации по применению компонента;
- Поставка образцов и прототипов;
- Техническая поддержка проекта;
- Защита от снятия компонента с производства.

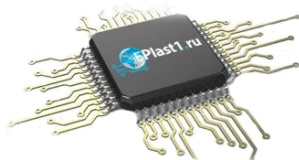

Как с нами связаться

Телефон: 8 (812) 309 58 32 (многоканальный)

Факс: 8 (812) 320-02-42

Электронная почта: org@eplast1.ru

Адрес: 198099, г. Санкт-Петербург, ул. Калинина, дом 2, корпус 4, литера А.