

REVISIONS				
P.	LTN.	DESCRIPTION	DATE	APVD.
		SEE LAST SHEET		

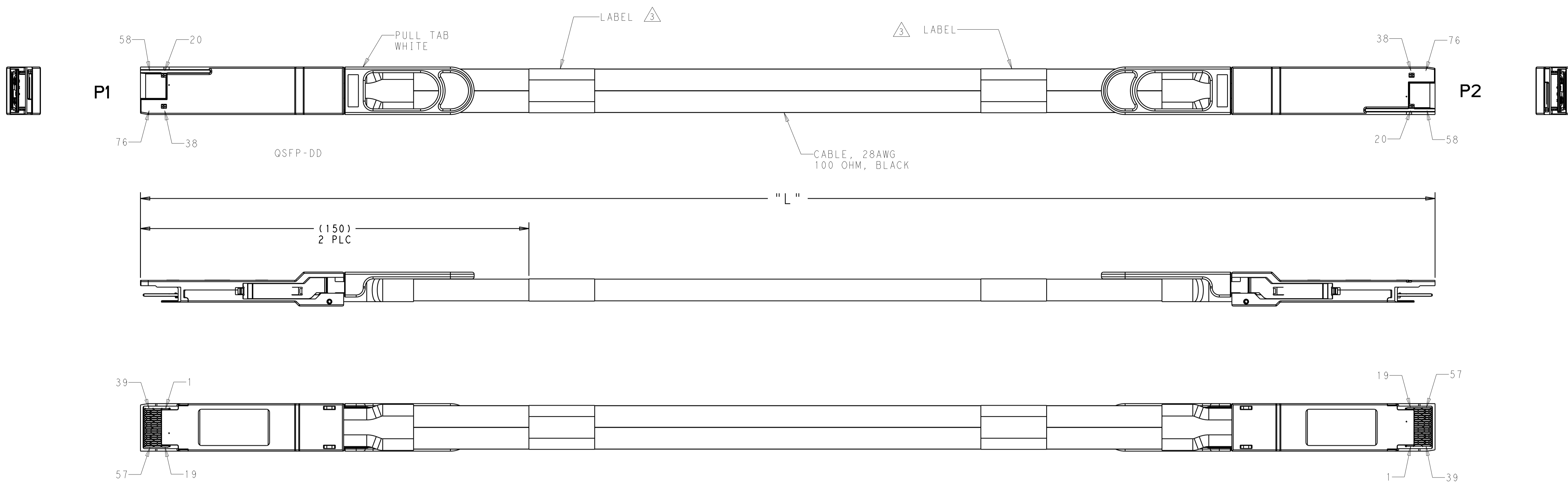

- SEE SHEET 2 FOR WIRING SCHEMATIC.
- ALL MATERIALS, COMPONENTS AND PROCESSES SHALL COMPLY WITH TEC-138-702. (CONTAINS NO BANNED OR RESTRICTED SUBSTANCES).

△ LABEL INFORMATION: -1 SHOWN.

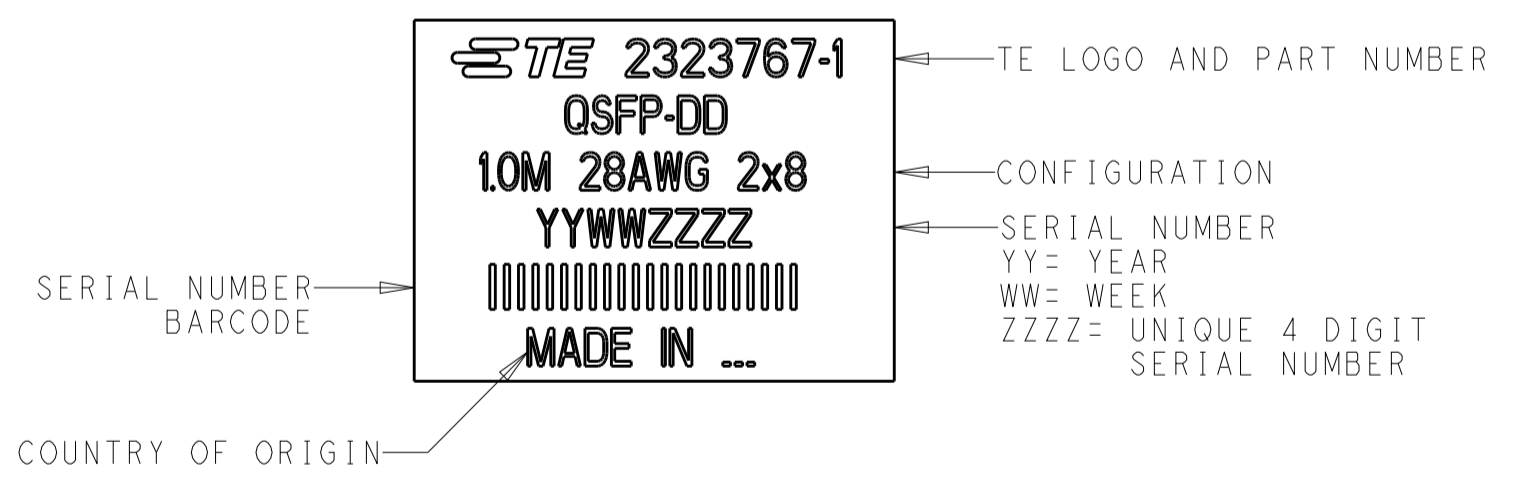

- THIS LENGTH DOES NOT MEET IEEE802.3cd SPECIFICATION (56G PAM-4) BUT DOES MEET IEEE802.3bj SPECIFICATION (28G NRZ).
- NO REACH SvHC SHALL BE CONTAINED ABOVE THE THRESHOLD AS DEFINED IN REACH SvHC COMPLIANCE DEFINITION IN ANNEX A OF TEC-138-702.
- CABLE ASSEMBLY 100% TESTED FOR OPENS, SHORTS AND PROPER EEPROM PROGRAM.
- THIS LENGTH DOES NOT MEET IEEE802.3cd SPECIFICATION (56G PAM-4) AND IEEE802.3bj SPECIFICATION (28G NRZ).

△	2.8M 28AWG 2X8	2800±30	2323767-8
△	3.5M 28AWG 2X8	3500±30	2323767-7
	0.5M 28AWG 2x8	500±20	2323767-6
△	3.0M 28AWG 2x8	3000±30	2323767-5
	2.5M 28AWG 2x8	2500±30	2323767-4
	2.0M 28AWG 2x8	2000±30	2323767-3
	1.5M 28AWG 2x8	1500±25	2323767-2
	1.0M 28AWG 2x8	1000±20	2323767-1
	CONFIGURATION	"L"	PART NO

**PRELIMINARY  
NOT RELEASED FOR PRODUCTION**

THIS DRAWING IS A CONTROLLED DOCUMENT.		DWN T. SMITH 16OCT2017 CHK K. STAUFFER 16OCT2017 APVD -	<b>STE</b> TE Connectivity		
DIMENSIONS:	TOLERANCES UNLESS OTHERWISE SPECIFIED:	PRODUCT SPEC	NAME CABLE ASSY, 28 AWG QSFP-DD		
mm	0 PLC ± 1 PLC ± 2 PLC ± 3 PLC ± 4 PLC ± ANGLES ±	APPLICATION SPEC	SIZE	CAGE CODE	DRAWING NO
MATERIAL	FINISH	WEIGHT	A1	00779	2323767
		CUSTOMER DRAWING	SCALE	SHEET	REV
			1:2	1 OF 3	8

THIS DRAWING IS UNPUBLISHED. RELEASED FOR PUBLICATION  
 © COPYRIGHT copyright\_d81e- ALL RIGHTS RESERVED.

REVISIONS				
P.	LTN	DESCRIPTION	DATE	APVD
		SEE SHEET 1		

P1			P2		
GND	1		20	GND	
TX2-	<b>2</b>	↔	<b>21</b>	RX2-	
TX2+	<b>3</b>	↔	<b>22</b>	RX2+	
GND	4		23	GND	
TX4-	<b>5</b>	↔	<b>24</b>	RX4-	
TX4+	<b>6</b>	↔	<b>25</b>	RX4+	
GND	7		26	GND	
ModseIL	8		27	ModPrsL	
ResetL	9		28	intL	
VccRx	10		29	VccTx	
SCL	11		30	Vcc1	
SDA	12		31	InitMode	
GND	13		32	GND	
RX3+	<b>14</b>	↔	<b>33</b>	TX3+	
RX3-	<b>15</b>	↔	<b>34</b>	TX3-	
GND	16		35	GND	
RX1+	<b>17</b>	↔	<b>36</b>	TX1+	
RX1-	<b>18</b>	↔	<b>37</b>	TX1-	
GND	19		38	GND	

GND	20		1	GND	
RX2-	<b>21</b>	↔	<b>2</b>	TX2-	
RX2+	<b>22</b>	↔	<b>3</b>	TX2+	
GND	23		4	GND	
RX4-	<b>24</b>	↔	<b>5</b>	TX4-	
RX4+	<b>25</b>	↔	<b>6</b>	TX4+	
GND	26		7	GND	
ModPrsL	27		8	ModseIL	
intL	28		9	ResetL	
VccTx	29		10	VccRx	
Vcc1	30		11	SCL	
InitMode	31		12	SDA	
GND	32		13	GND	
TX3+	<b>33</b>	↔	<b>14</b>	RX3+	
TX3-	<b>34</b>	↔	<b>15</b>	RX3-	
GND	35		16	GND	
TX1+	<b>36</b>	↔	<b>17</b>	RX1+	
TX1-	<b>37</b>	↔	<b>18</b>	RX1-	
GND	38		19	GND	

P1			P2		
GND	39		58	GND	
TX6-	<b>40</b>	↔	<b>59</b>	RX6-	
TX6+	<b>41</b>	↔	<b>60</b>	RX6+	
GND	42		61	GND	
TX8-	<b>43</b>	↔	<b>62</b>	RX8-	
TX8+	<b>44</b>	↔	<b>63</b>	RX8+	
GND	45		64	GND	
Reserved	46		65	NC	
VS1	47		66	Reserved	
VccRx1	48		67	VccTx1	
VS2	49		68	Vcc2	
VS3	50		69	Reserved	
GND	51		70	GND	
RX7+	<b>52</b>	↔	<b>71</b>	TX7+	
RX7-	<b>53</b>	↔	<b>72</b>	TX7-	
GND	54		73	GND	
RX5+	<b>55</b>	↔	<b>74</b>	TX5+	
RX5-	<b>56</b>	↔	<b>75</b>	TX5-	
GND	57		76	GND	

GND	58		39	GND	
RX6-	<b>59</b>	↔	<b>40</b>	TX6-	
RX6+	<b>60</b>	↔	<b>41</b>	TX6+	
GND	61		42	GND	
RX8-	<b>62</b>	↔	<b>43</b>	TX8-	
RX8+	<b>63</b>	↔	<b>44</b>	TX8+	
GND	64		45	GND	
NC	65		46	Reserved	
Reserved	66		47	VS1	
VccTx1	67		48	VccRx1	
Vcc2	68		49	VS2	
Reserved	69		50	VS3	
GND	70		51	GND	
TX7+	<b>71</b>	↔	<b>52</b>	RX7+	
TX7-	<b>72</b>	↔	<b>53</b>	RX7-	
GND	73		54	GND	
TX5+	<b>74</b>	↔	<b>55</b>	RX5+	
TX5-	<b>75</b>	↔	<b>56</b>	RX5-	
GND	76		57	GND	

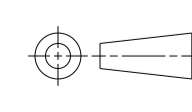
THIS DRAWING IS A CONTROLLED DOCUMENT.		DWN T. SMITH 16OCT2017 CHK K. STAUFFER 16OCT2017 APVD -	 TE Connectivity	
DIMENSIONS: mm 	TOLERANCES UNLESS OTHERWISE SPECIFIED: 0 PLC ± 1 PLC ± 2 PLC ± 3 PLC ± 4 PLC ± ANGLES ±	PRODUCT SPEC APPLICATION SPEC WEIGHT CUSTOMER DRAWING	NAME CABLE ASSY, 28 AWG QSFP-DD	SIZE CAGE CODE DRAWING NO A100779C=2323767
RESTRICTED TO			SCALE 1:2	SHEET 2 OF 3
			REV 8	

REVISIONS				
P. LTH	DESCRIPTION	DATE	DWN	APVD
	SEE SHEET 1			

2323767_C				STOCK DISPOSITION				
DRAWING TITLE				A: CONTINUE AS IS	D: USE OLD FIRST			
REVISION HISTORY				B: REWORK	E: PARTS TO CONFORM			
				C: SCRAP	F: OTHER			
DATE	REV	CHANGES	REASON	APPROVAL	INVENTORY (A,B,C,D,E,F)	WORK IN PROCESS (A,B,C,F)	SUPPLIER ORDERS (A,E,F)	OPEN CUST ORDERS (A,E,F)
16OCT2017	1	INITIAL DRAWING	PRELIMINARY	TS/KS	-	-	-	-
18OCT2017	2	ADDED NOTE 4	DRAWING CLARIFICATION	TS/KS				
23OCT2017	3	CHANGE LABEL TO REFLECT 1.0M LENGTH.	TYPO	KS/TS	E	E	E	E
07AUG2018	4	REVISED LENGTH TOLERANCE, ADDED ADDITIONAL LABEL	DRAWING CLARIFICATION	TS/KS	E	B	E	E
31DEC2018	5	UPDATE ODD PULL TAB, UPDATE BACK SHELL PER MSA4.0	DESIGN CHANGE	NN	E	E	E	E
30JAN2019	6	REMOVE THE LABEL OF THE SHELL	DESIGN UPDATE	NN	E	B	B	B
11FEB2019	7	ADD DASH NUMBER -7 FOR 3.5M LENGTH	DESIGN UPDATE	NN	E	B	B	B
20MAR2019	8	ADD DASH NUMBER -8 FOR 2.8M LENGTH	DESIGN UPDATE	FZ	E	B	B	B

THIS DRAWING IS A CONTROLLED DOCUMENT.		DWN T. SMITH 16OCT2017	TE Connectivity	
DIMENSIONS:		CHK K. STAUFFER 16OCT2017	NAME CABLE ASSY, 28 AWG QSFP-DD	
TOLERANCES UNLESS OTHERWISE SPECIFIED:		APVD	PRODUCT SPEC	
mm			APPLICATION SPEC	
0 PLC ±			SIZE CAGE CODE DRAWING NO	
1 PLC ±			A 100779 C=2323767	
2 PLC ±			RESTRICTED TO	
3 PLC ±				
4 PLC ±				
ANGLES ±				
FINISH		WEIGHT	SCALE 1:2 SHEET 3 OF 3 REV 8	
MATERIAL		CUSTOMER DRAWING		



Компания «ЭлектроПласт» предлагает заключение долгосрочных отношений при поставках импортных электронных компонентов на взаимовыгодных условиях!

Наши преимущества:

- Оперативные поставки широкого спектра электронных компонентов отечественного и импортного производства напрямую от производителей и с крупнейших мировых складов;
- Поставка более 17-ти миллионов наименований электронных компонентов;
- Поставка сложных, дефицитных, либо снятых с производства позиций;
- Оперативные сроки поставки под заказ (от 5 рабочих дней);
- Экспресс доставка в любую точку России;
- Техническая поддержка проекта, помощь в подборе аналогов, поставка прототипов;
- Система менеджмента качества сертифицирована по Международному стандарту ISO 9001;
- Лицензия ФСБ на осуществление работ с использованием сведений, составляющих государственную тайну;
- Поставка специализированных компонентов (Xilinx, Altera, Analog Devices, Intersil, Interpoint, Microsemi, Aeroflex, Peregrine, Syfer, Eurofarad, Texas Instrument, Miteq, Cobham, E2V, MA-COM, Hittite, Mini-Circuits, General Dynamics и др.);

Помимо этого, одним из направлений компании «ЭлектроПласт» является направление «Источники питания». Мы предлагаем Вам помощь Конструкторского отдела:

- Подбор оптимального решения, техническое обоснование при выборе компонента;
- Подбор аналогов;
- Консультации по применению компонента;
- Поставка образцов и прототипов;
- Техническая поддержка проекта;
- Защита от снятия компонента с производства.



#### Как с нами связаться

**Телефон:** 8 (812) 309 58 32 (многоканальный)

**Факс:** 8 (812) 320-02-42

**Электронная почта:** [org@eplast1.ru](mailto:org@eplast1.ru)

**Адрес:** 198099, г. Санкт-Петербург, ул. Калинина, дом 2, корпус 4, литера А.