

# Optically Coupled Isolator

OPI120, OPI123



## Features:

- 15 kV dc electrical isolation
- Choice of phototransistor or photodarlington output
- Hermetically sealed LED and photosensor
- Base contact for conventional transistor biasing (OP120 only)
- UL recognized File No. E58730
- Wide operating temperature range

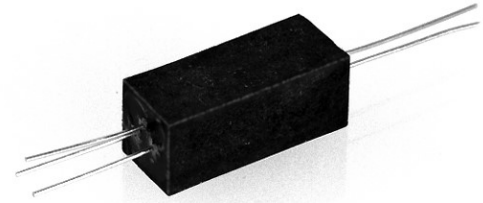

## Description:

Each Optoisolator in this data sheet contains an infrared Light Emitting Diode (LED) and a NPN silicon Photosensor. The **OPI120** has an 890 nm Light Emitting Diode (LED) and NPN phototransistor sensor, whereas the **OPI123** has a 890 nm LED and a photodarlington sensor. The devices are sealed in a precast opaque housing with a optically transmissive path between the LED and the photosensor.

The Optoisolators in this data sheet are UL recognized under UL file E58730.

This series is designed for transmission of information between one power supply voltage to another where the potentials during surge conditions are not greater than the guaranteed isolation voltage.

Custom electrical, wire and cabling and connectors are available. Contact your local representative or OPTEK for more information.

TX and TXV processing is available. For more information, contact your local representative or OPTEK.

## Applications:

- High voltage isolation between input and output
- Electrical isolation in dirty environments
- Industrial equipment
- Medical equipment
- Office equipment

Ordering Information							
Part Number	LED Peak Wavelength	Sensor	Isolation Voltage (,000)	CTR Min	I <sub>F</sub> (mA) Typ / Max	V <sub>CE</sub> (Volts) Max	Lead Length / Spacing
OPI120	890 nm	Transistor	15	20	10 / 50	25	0.40" / 0.75"
OPI123	or 935 nm	Darlington		50		20	



RoHS

## General Note

TT Electronics reserves the right to make changes in product specification without notice or liability. All information is subject to TT Electronics' own data and is considered accurate at time of going to print.

TT Electronics | OPTEK Technology, Inc.  
1645 Wallace Drive, Carrollton, TX 75006 | Ph: +1 972 323 2200  
sensors@ttelelectronics.com | www.ttelelectronics.com

# Optically Coupled Isolator

OPI120, OPI123



## Absolute Maximum Ratings (T<sub>A</sub> = 25° C unless otherwise noted)

Storage Temperature	-55° C to +125° C
Operating Temperature	-55° C to +100° C
Input-to-Output Isolation Voltage <sup>(1)</sup>	± 15 kVDC
Lead Soldering Temperature (1/16" (1.6 mm) from case for 5 seconds with soldering iron) <sup>(2)</sup>	260° C
<b>Input Diode</b>	
Forward DC Current <sup>(3)</sup>	150 mA
Reverse DC Voltage	3 V
Power Dissipation <sup>(4)</sup>	200 mW
<b>Output Photosensor</b>	
Collector-Emitter Voltage	25 V
OPI120	25 V
OPI123	20 V
Emitter-Collector Voltage	5 V
Collector-Base Voltage	25 V
OPI120	25 V
Power Dissipation <sup>(5)</sup>	250 mW

**Notes:**

- (1) Measured with input and output leads shorted in air with a maximum relative humidity of 50%. UL recognition is for 15kV dc for one minute.
- (2) RMA flux is recommended. The duration can be extended to 10 seconds maximum when flow soldering.
- (3) Derate linearly 2.0 mA/°C above 25°C.
- (4) Derate linearly 2.67 mW/°C above 25°C.
- (5) Derate linearly 3.33 mW/°C above 25°C.

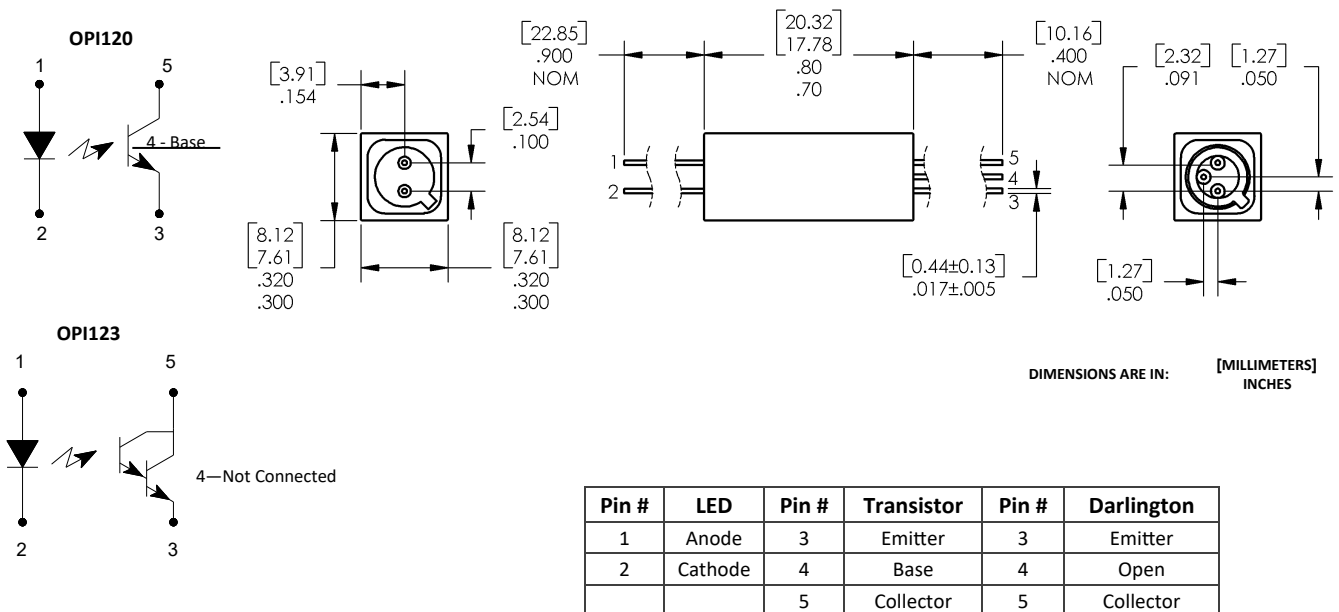

**General Note**

TT Electronics reserves the right to make changes in product specification without notice or liability. All information is subject to TT Electronics' own data and is considered accurate at time of going to print.

TT Electronics | OPTEK Technology, Inc.  
 1645 Wallace Drive, Carrollton, TX 75006 | Ph: +1 972 323 2200  
 sensors@ttelectronics.com | www.ttelectronics.com

# Optically Coupled Isolator

OPI120, OPI123



## Electrical Characteristics (-40° C to +85° C unless otherwise noted)

SYMBOL	PARAMETER	MIN	TYP	MAX	UNITS	TEST CONDITIONS
<b>Input Diode</b>						
$V_F$	Forward Voltage OPI120 OPI123	- -	- -	1.5 1.5	V	$I_F = 30\text{ mA}$ $I_F = 10\text{ mA}$
$I_R$	Reverse Current	-	-	100	$\mu\text{A}$	$V_R = 3\text{ V}$
<b>Output Photosensor (See OP236 for additional information - for reference only)</b>						
$V_{(BR)CEO}$	Collector-Emitter Breakdown Voltage OPI120 OPI123	25 20	- -	- -	V	$I_C = 1\text{ mA}$ $I_C = 1\text{ mA}$
$V_{(BR)ECO}$	Emitter-Collector Breakdown Voltage	5	-	-	V	$I_E = 100\ \mu\text{A}$
$V_{(BR)CBO}$	Collector-Base Breakdown Voltage OPI120	25	-	-	V	$I_C = 1\text{ mA}$
$I_{CEO}$	Collector-Emitter Dark Current	-	-	100	nA	$V_{CE} = 10\text{ V}$
<b>Coupled (See OP804 and OP805 for additional information - for reference only)</b>						
$I_C/I_F$	DC Current Transfer Ratio OPI120 OPI123	20 50	70 -	- -	%	$I_F = 10\text{ mA}, V_{CE} = 5\text{ V}$ $I_F = 10\text{ mA}, V_{CE} = 2\text{ V}$
$V_{CE(SAT)}$	Collector Saturation Voltage OPI120 OPI123	- -	- -	0.5 1.2	V	$I_F = 30\text{ mA}, I_C = 1\text{ mA}$ $I_F = 5\text{ mA}, I_C = 1\text{ mA}$
$I_{C(ON)}$	On Collector Current OPI120 OPI123	2.0 5.0	- -	50 -	mA	$I_F = 10\text{ mA}, V_{CE} = 5\text{ V}$ $I_F = 10\text{ mA}, V_{CE} = 2\text{ V}$
$I_{CB(ON)}$	On Collector Base Current—OPI120	15	-	-	$\mu\text{A}$	$I_F = 30\text{ mA}, V_{CB} = 5\text{ V}$
$V_{ISO}$	Isolation Voltage <sup>(1)</sup>	15	-	-	kV	See note 1
$t_r, t_f$	Output Rise Time, Output Fall Time OPI120 OPI123	- -	2 40	- -	$\mu\text{s}$	See Test Circuit

**Notes:**

(1) Measured with input and output leads shorted in air with a maximum relative humidity of 50%.

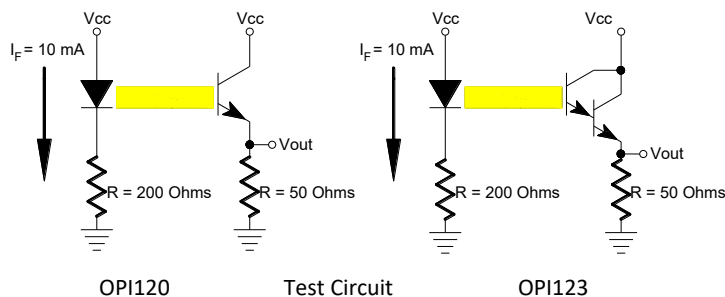

**General Note**

TT Electronics reserves the right to make changes in product specification without notice or liability. All information is subject to TT Electronics' own data and is considered accurate at time of going to print.

TT Electronics | OPTEK Technology, Inc.  
1645 Wallace Drive, Carrollton, TX 75006 | Ph: +1 972 323 2200  
sensors@ttelelectronics.com | www.ttelelectronics.com



Компания «ЭлектроПласт» предлагает заключение долгосрочных отношений при поставках импортных электронных компонентов на взаимовыгодных условиях!

Наши преимущества:

- Оперативные поставки широкого спектра электронных компонентов отечественного и импортного производства напрямую от производителей и с крупнейших мировых складов;
- Поставка более 17-ти миллионов наименований электронных компонентов;
- Поставка сложных, дефицитных, либо снятых с производства позиций;
- Оперативные сроки поставки под заказ (от 5 рабочих дней);
- Экспресс доставка в любую точку России;
- Техническая поддержка проекта, помощь в подборе аналогов, поставка прототипов;
- Система менеджмента качества сертифицирована по Международному стандарту ISO 9001;
- Лицензия ФСБ на осуществление работ с использованием сведений, составляющих государственную тайну;
- Поставка специализированных компонентов (Xilinx, Altera, Analog Devices, Intersil, Interpoint, Microsemi, Aeroflex, Peregrine, Syfer, Eurofarad, Texas Instrument, Miteq, Cobham, E2V, MA-COM, Hittite, Mini-Circuits, General Dynamics и др.);

Помимо этого, одним из направлений компании «ЭлектроПласт» является направление «Источники питания». Мы предлагаем Вам помощь Конструкторского отдела:

- Подбор оптимального решения, техническое обоснование при выборе компонента;
- Подбор аналогов;
- Консультации по применению компонента;
- Поставка образцов и прототипов;
- Техническая поддержка проекта;
- Защита от снятия компонента с производства.



#### Как с нами связаться

**Телефон:** 8 (812) 309 58 32 (многоканальный)

**Факс:** 8 (812) 320-02-42

**Электронная почта:** [org@eplast1.ru](mailto:org@eplast1.ru)

**Адрес:** 198099, г. Санкт-Петербург, ул. Калинина, дом 2, корпус 4, литера А.