

AMPHENOL PART NUMBER CONFIGURATION
U95 - T 1 X 1 - 1 X X X

HEAT SINK OPTION

- 1** = NO HEAT SINK OR CLIP SHIPPED
- 5** = ROUND PIN STYLE (H=6.5mm; SAN HEIGHT)--(NOT AVAILABLE WITH QUAD LIGHT PIPE)
- 6** = ROUND PIN STYLE (H=4.2mm; PCI HEIGHT)--(NOT AVAILABLE WITH QUAD LIGHT PIPE)
- 7** = ROUND PIN STYLE (H=13.5mm; TALL)--(NOT AVAILABLE WITH QUAD LIGHT PIPE)
- A** = SQUARE PIN STYLE (H=6.5mm; SAN HEIGHT)
- B** = SQUARE PIN STYLE (H=4.2mm; PCI HEIGHT)
- C** = SQUARE PIN STYLE (H=13.5mm; TALL)
- N** = PIN-FIN STYLE FOR SIDE TO SIDE AIR FLOW (H=6.5mm; SAN HEIGHT)
- P** = PIN-FIN STYLE FOR SIDE TO SIDE AIR FLOW (H=4.2mm; PCI HEIGHT)
- R** = PIN-FIN STYLE FOR SIDE TO SIDE AIR FLOW (H=13.5mm; TALL)
- Y** = EXTRUDED FIN STYLE FOR FRONT - BACK AIR FLOW (H=6.94mm)
- W** = EXTRUDED FIN STYLE FOR FRONT - BACK AIR FLOW (H=8.72mm)

NOTE: FOR DIMENSION "H" SEE SHEET 2

PACKAGING OPTION

- 1** = TRAY PACKAGING (LIGHT PIPE AND/OR HEAT SINK SHIPPED LOOSE IF ORDERED)
- A** = TRAY PACKAGING (LIGHT PIPE AND/OR HEAT SINK ASSEMBLED TO THE CAGE)

OPTIONAL LIGHT PIPE

- 0** = NO LIGHT PIPE
- 1** = DUAL BARREL LIGHT PIPE - ROUND OUTLET
- 7** = SINGLE BARREL LIGHT PIPE - ROUND OUTLET
- 4** = QUAD BARREL LIGHT PIPE - ROUND OUTLET

OPTIONAL DUST COVER (CONDUCTIVE)

- 0** = WITHOUT DUST COVER
- D** = WITH DUST COVER (SHIPPED LOOSE PIECE)

REVISIONS			
REV	DESCRIPTION, ECN, EAR NO.	DATE	APP'D
H	ADDED HEAT SINK OPTIONS	JAN. 16/15	AC
J	PCB FRONT EDGE NOTE ADDED	APR 22/15	AC
K	COMPLIANT PIN LEAD IN TIP SHORTENED FOR THINNER B2B PCB APPLICATION	JUL 10/15	AC

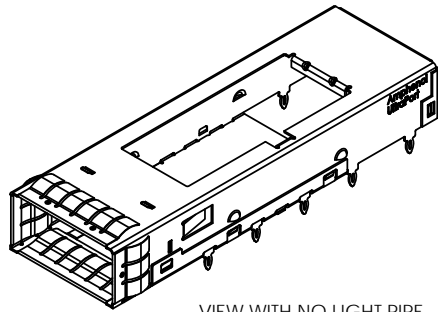

VIEW WITH NO LIGHT PIPE AND NO HEAT SINK (NO DUST COVER)
(P/N U95-T111-1001)

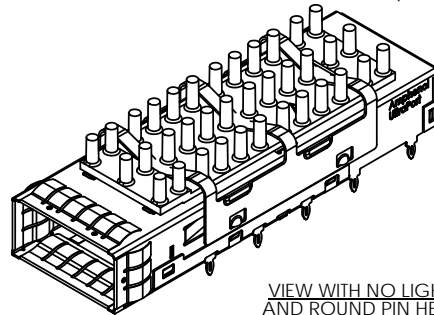

VIEW WITH NO LIGHT PIPE AND ROUND PIN HEAT SINK (NO DUST COVER)
(P/N U95-T151-100A)

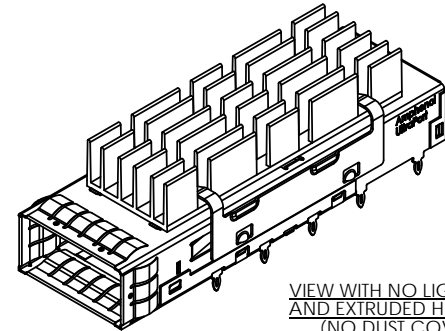

VIEW WITH NO LIGHT PIPE AND EXTRUDED HEAT SINK (NO DUST COVER)
(P/N U95-T1W1-100A)

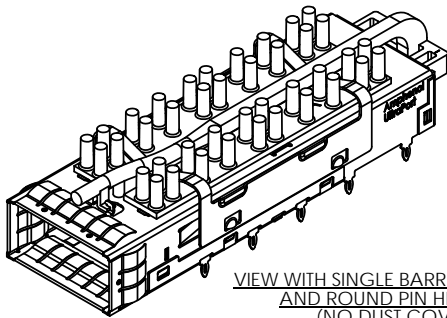

VIEW WITH SINGLE BARREL LIGHT PIPE AND ROUND PIN HEAT SINK (NO DUST COVER)
(P/N U95-T151-107A)

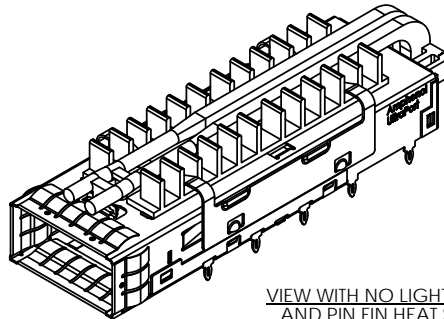

VIEW WITH NO LIGHT PIPE AND PIN FIN HEAT SINK (NO DUST COVER)
(P/N U95-T1N1-101A)

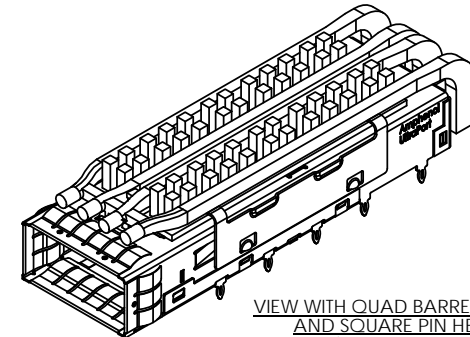

VIEW WITH QUAD BARREL LIGHT PIPE AND SQUARE PIN HEAT SINK (NO DUST COVER)
(P/N U95-T1A1-104A)

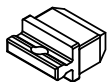

CONDUCTIVE DUST COVER SHOWN (OPTIONAL) (SHIPPED LOOSE)
(P/N U79-111-9000-P)



UNLESS SPECIFIED OTHERWISE	DRAWN	A.C.	JUL5/13
UNIT MILLIMETERS	CHECKED	ZLJ	JUL5/13
REFERENCE IN PARENTHESES	M.E. APP'D		
	Q.A. APP'D		
GENERAL TOLERANCES	DWG APP'D	ZLJ	JUL5/13
1 DECIMAL PLACE ±0.2	ENG. REL. NO.	-	
2 DECIMAL PLACES ±0.15	REF.		
ANGULAR DEGREES ±1°	THIRD ANGLE PROJECTION		DO NOT SCALE DRAWING

Amphenol High Speed Interconnects
A Division of Amphenol Corp. www.amphenol-highspeed.com

UltraPort QSFP 1X1 CAGE ASSEMBLY THRU BEZEL TWO REAR PIN WITH HEAT SINK AND LIGHT PIPE OPTIONS

DWG. NO.	P-U95-T1X1-1XXX	REV	K
CODE ID NO.	03554	DWG SIZE:	C
SCALE:	3:1	SHEET 1 OF 5	

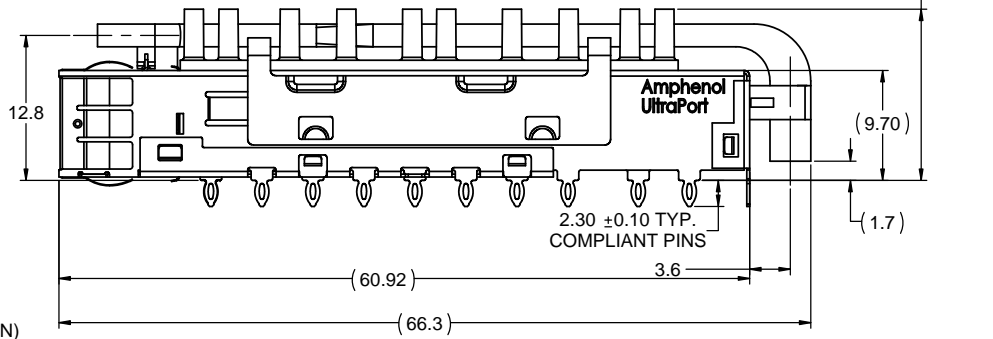
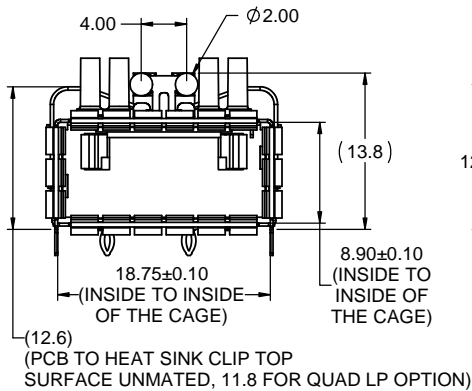

VIEW WITH DUAL BARREL LIGHT PIPE
AND ROUND PIN HEAT SINK
(NO DUST COVER)
(P/N U95-T151-101A)

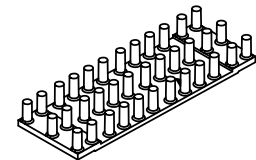
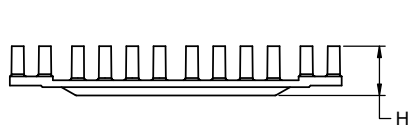
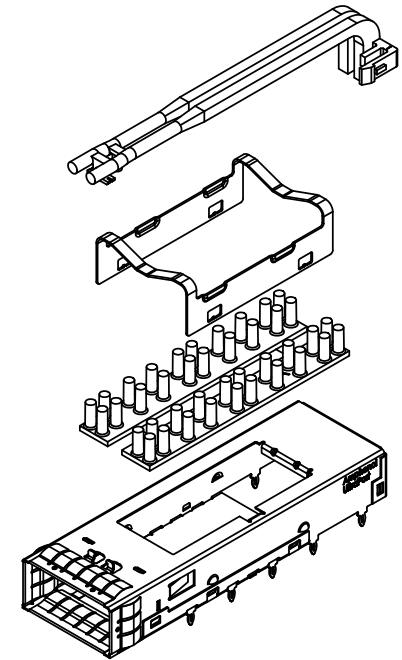

ROUND PIN STYLE WITHOUT LP
(FOR REFERENCE ONLY)

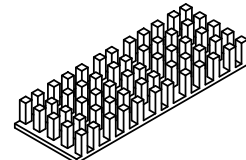

SQUARE PIN STYLE WITHOUT LP
(FOR REFERENCE ONLY)

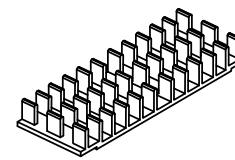

PIN FIN STYLE WITHOUT LP
(FOR REFERENCE ONLY)

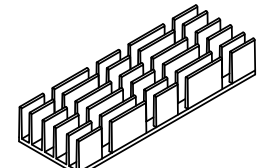

FIN STYLE WITHOUT LP
(FOR REFERENCE ONLY)

PART NUMBER	DIM "J"	DIM "H"
U95-T15(N, A)1-1XXX	15.10	6.50
U95-T16(P, B)1-1XXX	12.80	4.20
U95-T17(R, C)1-1XXX	22.10	13.50
U95-T1Y1-1XXX	15.54	6.94
U95-T1W1-1XXX	17.32	8.72

NOTES:

- MATERIAL:
CAGE AND EMI SPRINGS: COPPER ALLOY
CAGE PLATING: 2.54µm [100µ"] MIN. NICKEL.
LIGHT PIPE: GE LEXAN RESIN, CLEAR OPTICAL GRADE
HEAT SINK: ALUMINUM ALLOY, NICKEL PLATED
HEAT SINK CLIP: STAINLESS STEEL
DUST COVER: CONDUCTIVE RUBBER
- DUST COVER IS SHIPPED AS A LOOSE PIECE IF ORDERED.
- DIMENSION "J" IS IN THE UNPLUGGED STATE

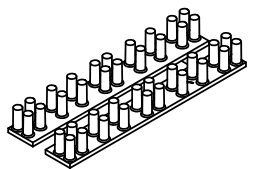

ROUND PIN STYLE WITH LP
(FOR REFERENCE ONLY)
LAYOUT MAY VARY W/ LP OPTION)

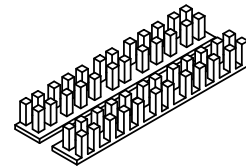

SQUARE PIN STYLE WITH LP
(FOR REFERENCE ONLY)
LAYOUT MAY VARY W/ LP OPTION)

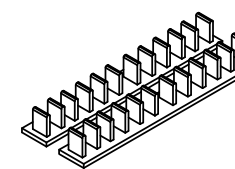

PIN FIN STYLE WITH LP
(FOR REFERENCE ONLY)
LAYOUT MAY VARY W/ LP OPTION)

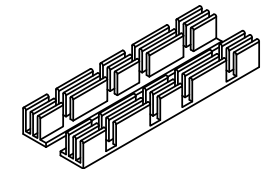

FIN STYLE WITH LP
(FOR REFERENCE ONLY)
LAYOUT MAY VARY W/ LP OPTION)

UNLESS SPECIFIED OTHERWISE		DRAWN	A.C.	JUL5/13
UNIT	MILLIMETERS	CHECKED	ZLJ	JUL5/13
REFERENCE IN PARENTHESES		M.E. APP'D		
		Q.A. APP'D		
GENERAL TOLERANCES		DWG APP'D	ZLJ	JUL5/13
1 DECIMAL PLACE	±0.2	ENG. REL. NO.		
2 DECIMAL PLACES	±0.15	REF.		
ANGULAR DEGREES	±1°	THIRD ANGLE PROJECTION		

Amphenol High Speed Interconnects			
A Division of Amphenol Corp. www.amphenol-highspeed.com			
UltraPort QSFP 1X1 CAGE ASSEMBLY THRU BEZEL TWO REAR PIN WITH HEAT SINK AND LIGHT PIPE OPTIONS			
DWG. NO.	P-U95-T1X1-1XXX		REV K
CODE ID NO.	03554	DWG SIZE: C	SCALE: 3:1 SHEET 2 OF 5

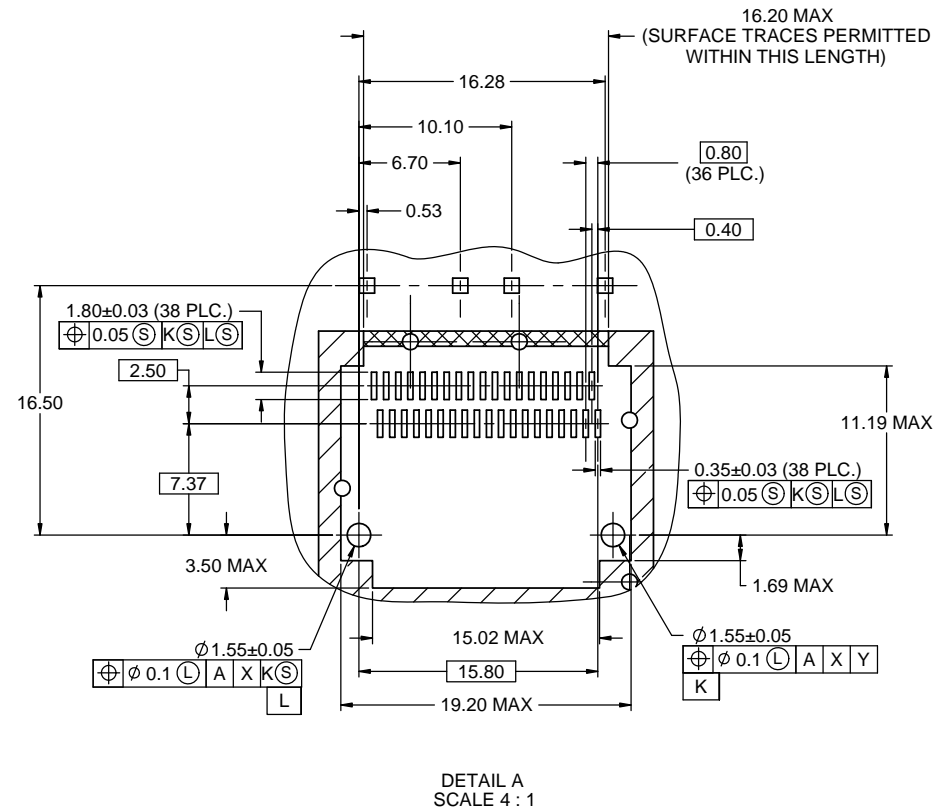
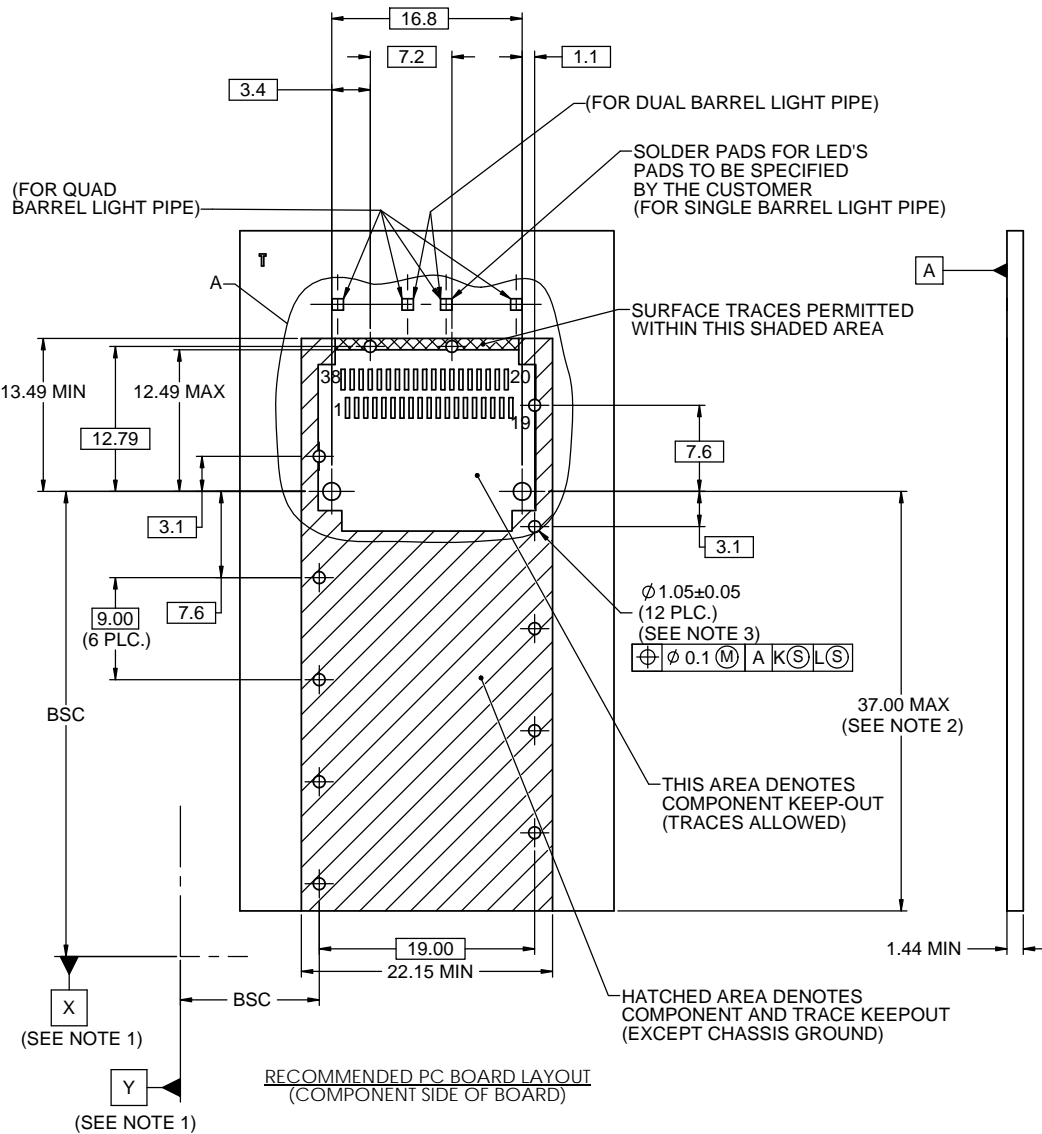

NOTES:

- DATUMS X AND Y ESTABLISHED BY CUSTOMER'S FIDUCIAL.
- LOCATION OF EDGE OF PCB IS APPLICATION SPECIFIC.
- FINISHED HOLE SIZE.

THIS DOCUMENT CONTAINS PROPRIETARY INFORMATION AND SUCH INFORMATION MAY NOT BE DISCLOSED TO OTHERS FOR ANY PURPOSE OR USED FOR MANUFACTURING PURPOSES WITHOUT WRITTEN PERMISSION FROM AMPHENOL CANADA CORP.

UNLESS SPECIFIED OTHERWISE	DRAWN	A.C.	JUL5/13
UNIT	MILLIMETERS	CHECKED	ZLJ
REFERENCE IN PARENTHESES	M.E. APPD	Q.A. APPD	
GENERAL TOLERANCES	DWG APPD	ZLJ	JUL5/13
1 DECIMAL PLACE	±0.2	ENG. REL. NO.	-
2 DECIMAL PLACES	±0.15	REF.	
ANGULAR DEGREES	±1°	THIRD ANGLE PROJECTION	
		DO NOT SCALE DRAWING	

Amphenol High Speed Interconnects A Division of Amphenol Corp. www.amphenol-highspeed.com			
UltraPort QSFP 1X1 CAGE ASSEMBLY THRU BEZEL TWO REAR PIN WITH HEAT SINK AND LIGHT PIPE OPTIONS			
DWG. NO.	P-U95-T1X1-1XXX		REV K
CODE ID NO.	03554	DWG SIZE: C	SCALE: 3:1
			SHEET 3 OF 5

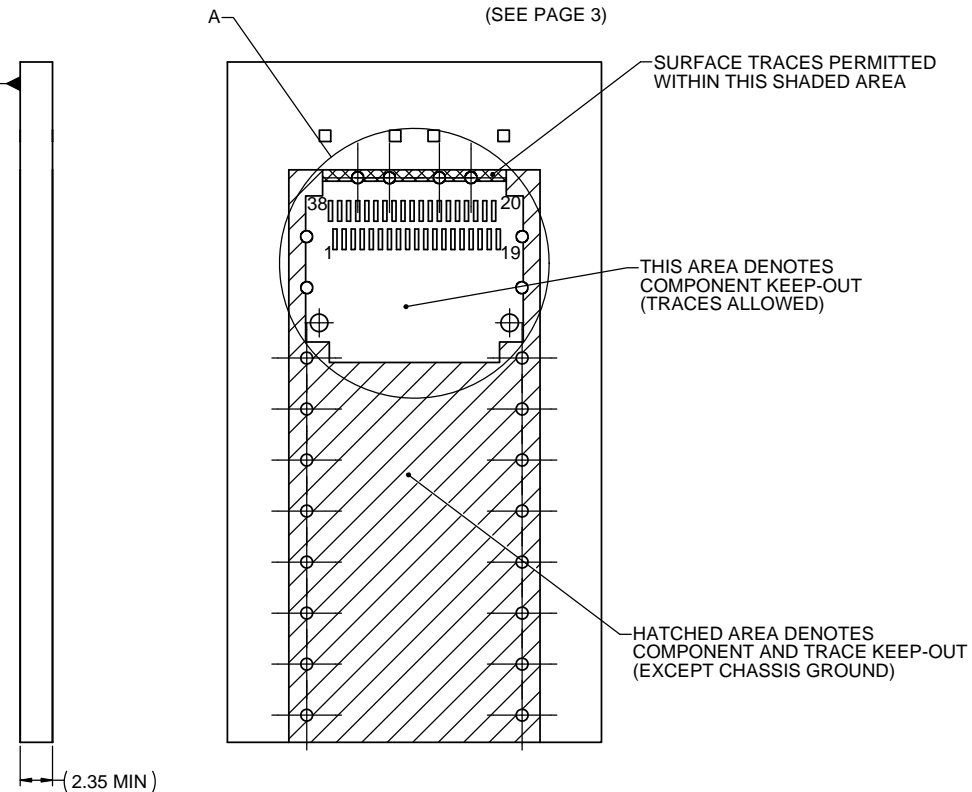
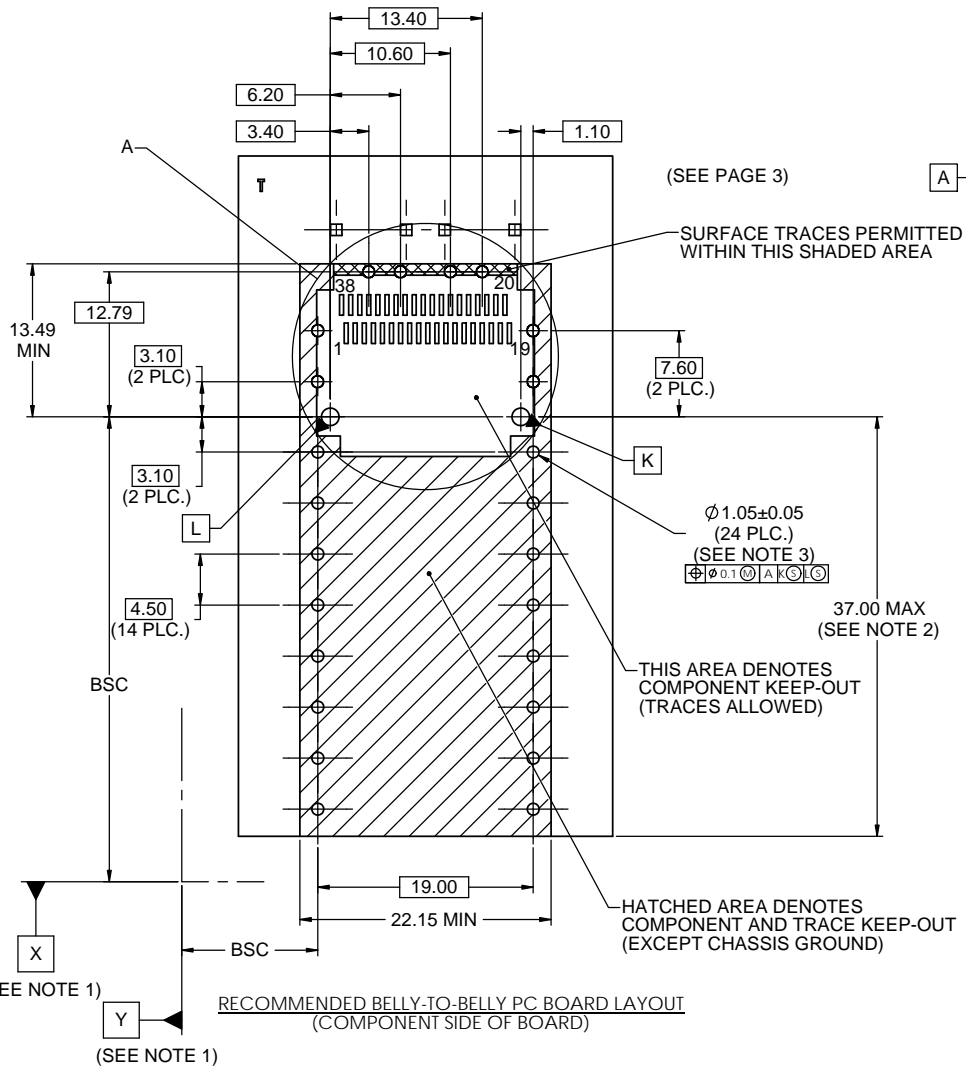

- NOTES:
- DATUMS X AND Y ESTABLISHED BY CUSTOMER'S FIDUCIAL.
 - LOCATION OF EDGE OF PCB IS APPLICATION SPECIFIC.
 - FINISHED HOLE SIZE.

THIS DOCUMENT CONTAINS PROPRIETARY INFORMATION AND SUCH INFORMATION MAY NOT BE DISCLOSED TO OTHERS FOR ANY PURPOSE OR USED FOR MANUFACTURING PURPOSES WITHOUT WRITTEN PERMISSION FROM AMPHENOL CANADA CORP.

UNLESS SPECIFIED OTHERWISE		DRAWN	A.C.	JUL5/13
UNIT	MILLIMETERS	CHECKED	ZLJ	JUL5/13
REFERENCE IN PARENTHESES		M.E. APPD		
		Q.A. APPD		
GENERAL TOLERANCES		DWG APPD	ZLJ	JUL5/13
1 DECIMAL PLACE	±0.2	ENG. REL. NO.		
2 DECIMAL PLACES	±0.15	REF.		
ANGULAR DEGREES	±1°	THIRD ANGLE PROJECTION		DO NOT SCALE DRAWING

Amphenol High Speed Interconnects
 A Division of Amphenol Corp. www.amphenol-highspeed.com

UltraPort QSFP 1X1 CAGE ASSEMBLY THRU BEZEL TWO REAR PIN WITH HEAT SINK AND LIGHT PIPE OPTIONS

DWG. NO. **P-U95-T1X1-1XXX** REV **K**

CODE ID NO. 03554 DWG SIZE: C SCALE: 3:1 SHEET 4 OF 5

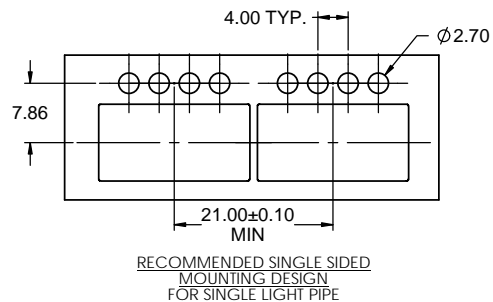
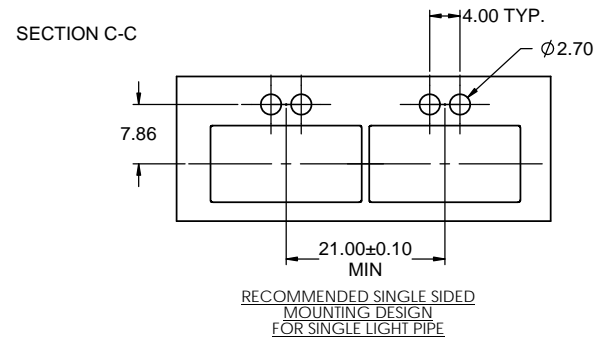
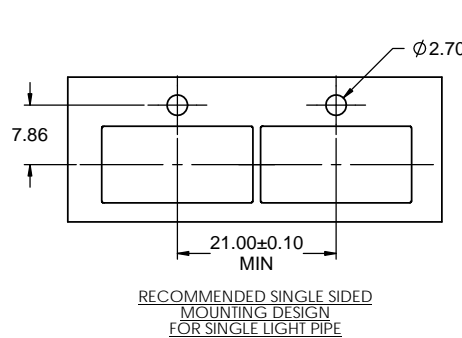
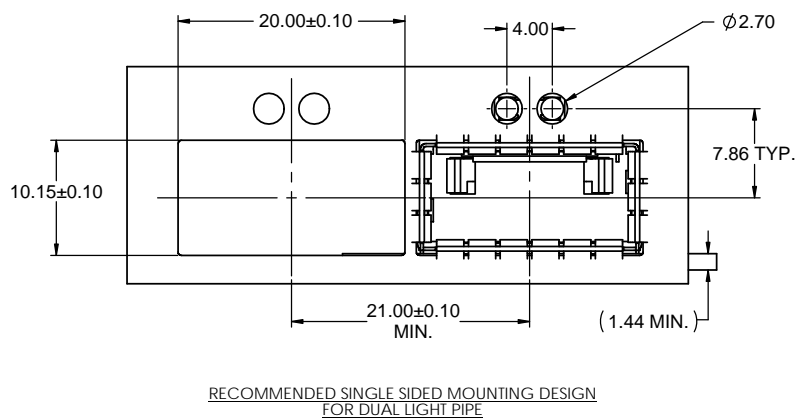
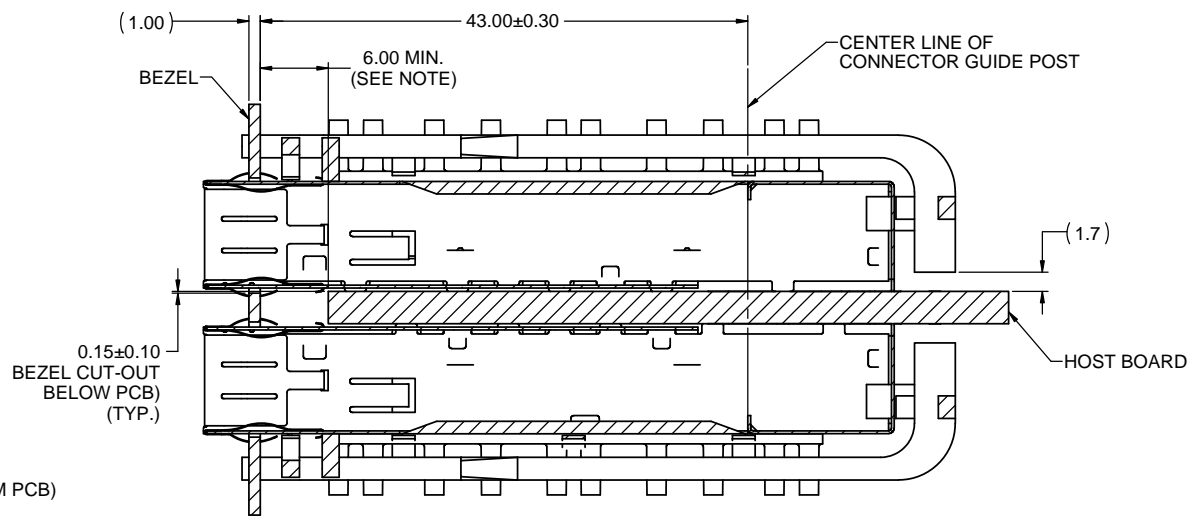
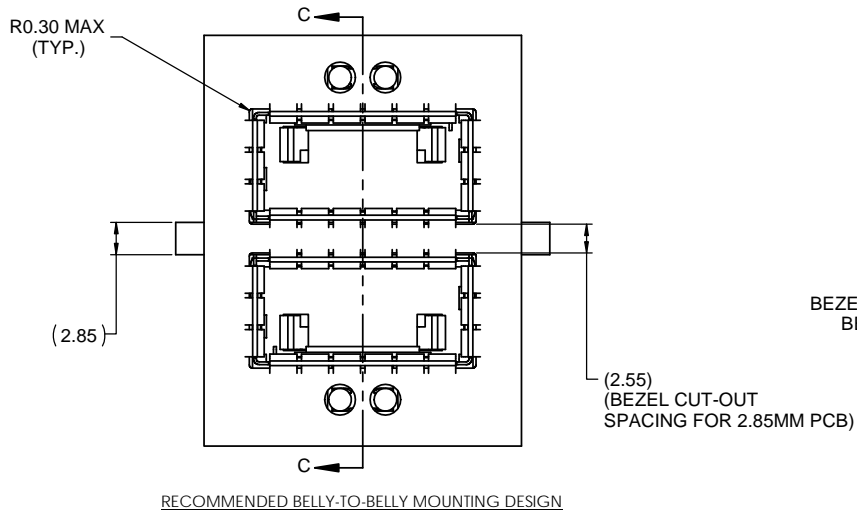

NOTES:
LOCATION OF EDGE OF PCB IS APPLICATION SPECIFIC.

THIS DOCUMENT CONTAINS PROPRIETARY INFORMATION AND SUCH INFORMATION MAY NOT BE DISCLOSED TO OTHERS FOR ANY PURPOSE OR USED FOR MANUFACTURING PURPOSES WITHOUT WRITTEN PERMISSION FROM AMPHENOL CANADA CORP.

UNLESS SPECIFIED OTHERWISE	DRAWN	A.C.	JUL5/13
UNIT	MILLIMETERS	CHECKED	ZLJ
REFERENCE IN PARENTHESES	M.E. APP'D	Q.A. APP'D	
GENERAL TOLERANCES	DWG APP'D	ZLJ	JUL5/13
1 DECIMAL PLACE	±0.2	ENG. REL. NO.	-
2 DECIMAL PLACES	±0.15	REF.	
ANGULAR DEGREES	±1°	THIRD ANGLE PROJECTION	DO NOT SCALE DRAWING

Amphenol High Speed Interconnects
A Division of Amphenol Corp. www.amphenol-highspeed.com

UltraPort QSFP 1X1 CAGE ASSEMBLY THRU BEZEL TWO REAR PIN WITH HEAT SINK AND LIGHT PIPE OPTIONS

DWG. NO.	P-U95-T1X1-1XXX	REV	K
CODE ID NO.	03554	DWG SIZE:	C
SCALE:	3:1	SHEET	5 OF 5



Компания «ЭлектроПласт» предлагает заключение долгосрочных отношений при поставках импортных электронных компонентов на взаимовыгодных условиях!

Наши преимущества:

- Оперативные поставки широкого спектра электронных компонентов отечественного и импортного производства напрямую от производителей и с крупнейших мировых складов;
- Поставка более 17-ти миллионов наименований электронных компонентов;
- Поставка сложных, дефицитных, либо снятых с производства позиций;
- Оперативные сроки поставки под заказ (от 5 рабочих дней);
- Экспресс доставка в любую точку России;
- Техническая поддержка проекта, помощь в подборе аналогов, поставка прототипов;
- Система менеджмента качества сертифицирована по Международному стандарту ISO 9001;
- Лицензия ФСБ на осуществление работ с использованием сведений, составляющих государственную тайну;
- Поставка специализированных компонентов (Xilinx, Altera, Analog Devices, Intersil, Interpoint, Microsemi, Aeroflex, Peregrine, Syfer, Eurofarad, Texas Instrument, Miteq, Cobham, E2V, MA-COM, Hittite, Mini-Circuits, General Dynamics и др.);

Помимо этого, одним из направлений компании «ЭлектроПласт» является направление «Источники питания». Мы предлагаем Вам помощь Конструкторского отдела:

- Подбор оптимального решения, техническое обоснование при выборе компонента;
- Подбор аналогов;
- Консультации по применению компонента;
- Поставка образцов и прототипов;
- Техническая поддержка проекта;
- Защита от снятия компонента с производства.



Как с нами связаться

Телефон: 8 (812) 309 58 32 (многоканальный)

Факс: 8 (812) 320-02-42

Электронная почта: org@eplast1.ru

Адрес: 198099, г. Санкт-Петербург, ул. Калинина, дом 2, корпус 4, литера А.