

DATA SHEET

TRANSIENT VOLTAGE SUPPRESSORS

AC/DC POWER SUPPLY

30KPA series

RoHS compliant & Halogen free



Product specification— April 29, 2019 V.0



Transient Voltage Suppressors (TVS) Data Sheet

Features

- Glass passivated junction
- Low inductance
- Excellent clamping capability
- 30000W peak pulse power capability at 10/1000 μ s waveform, repetition rate (duty cycle): 0.05%
- Fast response time
- Typical I_R less than 2 μ A above 40V.
- High Temperature soldering guaranteed: 265 $^{\circ}$ C/10 seconds/.375", (9.5mm) lead length, 5lbs (2.3kg) tension
- Plastic package has underwriters laboratory flammability 94V-0
- Meets MSL level 1, per J-STD-020
- Safety certification: UL: E244458



Mechanical Data

- Case: Moulded plastic over glass passivated junction
- Terminal: Plated Axial leads, solderable per MIL-STD-750, Method 2026
- Polarity: Color band denotes cathode except bi-directional models
- Mounting Position: Any
- Weight: 2.46g

Applications

- I/O interface
- AC/DC power supply
- Low frequency signal transmission line (RS232, RS485, etc.)

Maximum Ratings and Characteristics

Ratings at 25 $^{\circ}$ C ambient temperature unless otherwise specified.

Rating	Symbol	Value	Units
Peak pulse power dissipation at 10/1000 μ s waveform (Note1, Fig.1)	P_{PPM}	Minimum 30000	Watts
Peak pulse current of at 10/1000 μ s waveform (Note 1, Fig.3)	I_{PPM}	See Table	Amps
Steady state power dissipation at $T_L=75^{\circ}$ C (Fig.5)	$P_{M(AV)}$	8.0	Watts
Peak forward surge current, 8.3ms single half sine-wave superimposed on rated load, (JEDEC Method) (Note2, Fig.6)	I_{FSM}	400	Amps
Operating junction and Storage Temperature Range.	T_J, T_{STG}	-55 to +175	$^{\circ}$ C
Typical thermal resistance junction to lead	$R_{\theta JL}$	8	$^{\circ}$ C/W
Typical thermal resistance junction to ambient	$R_{\theta JA}$	40	$^{\circ}$ C/W

Notes: 1. Non-repetitive current pulse, per Fig.3 and derated above $T_A=25^{\circ}$ C per Fig.2.

2. 8.3ms single half sine-wave, or equivalent square wave, duty cycle=4 pulses per minutes maximum.

Dimensions (P600)

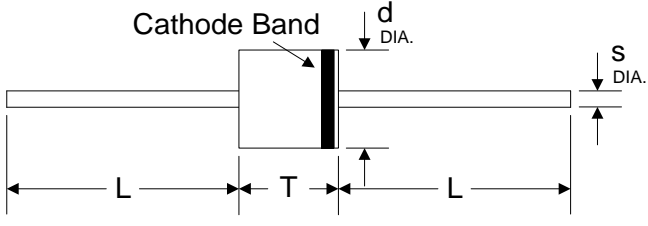

Symbol	Millimeters		Inches	
	Min.	Max.	Min.	Max.
L	25.40	-	1.000	-
T	8.60	9.10	0.340	0.360
d	8.60	9.10	0.340	0.360
s	1.19	1.32	0.047	0.052

Part Number Code

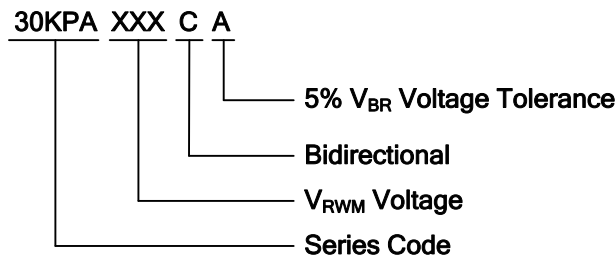

Ordering Code for different package

Box package: Add suffix “/B” at the end of the part number, such as 30KPA75A/B

Reel package: Add suffix “/TR13” at the end of the part number, such as 30KPA160CA/TR13

Electrical Characteristics ($T_A=25^{\circ}C$)

Part Number		Reverse Stand-Off Voltage	Breakdown Voltage @ I_T	Test Current	Maximum Clamping Voltage @ I_{PP}	Peak Pulse Current	Reverse Leakage @ V_{RWM}
Unidirectional	Bidirectional	$V_{RWM}(V)$	$V_{BR}(V)$	$I_T(mA)$	$V_C(V)$	$I_{PP}(A)$	$I_R(\mu A)$
30KPA28A	30KPA28CA	28.0	31.28~34.57	50	50.0	606.0	5000
30KPA30A	30KPA30CA	30.0	33.51~37.04	50	55.2	548.9	5000
30KPA33A	30KPA33CA	33.0	36.90~40.78	50	58.5	517.9	5000
30KPA36A	30KPA36CA	36.0	40.20~44.43	50	61.8	490.3	5000
30KPA39A	30KPA39CA	39.0	43.60~48.19	20	67.2	450.9	2000
30KPA42A	30KPA42CA	42.0	46.90~51.84	10	72.0	420.8	1000
30KPA43A	30KPA43CA	43.0	48.00~53.05	10	73.0	415.1	1000
30KPA45A	30KPA45CA	45.0	50.30~55.59	5	77.4	391.5	250
30KPA48A	30KPA48CA	48.0	53.60~59.24	5	81.6	371.3	150
30KPA51A	30KPA51CA	51.0	57.00~63.00	5	86.4	350.7	50
30KPA54A	30KPA54CA	54.0	60.30~66.65	5	91.4	331.5	20
30KPA58A	30KPA58CA	58.0	64.80~71.62	5	92.4	327.9	20

Transient Voltage Suppressors

30KPA

Part Number		Reverse Stand-Off Voltage	Breakdown Voltage @ I_T	Test Current	Maximum Clamping Voltage @ I_{PP}	Peak Pulse Current	Reverse Leakage @ V_{RWM}
Unidirectional	Bidirectional	$V_{RWM}(V)$	$V_{BR}(V)$	$I_T(mA)$	$V_C(V)$	$I_{PP}(A)$	$I_R(\mu A)$
30KPA60A	30KPA60CA	60.0	67.00~74.05	5	102.0	297.1	15
30KPA64A	30KPA64CA	64.0	71.50~79.03	5	104.0	291.3	10
30KPA66A	30KPA66CA	66.0	73.70~81.46	5	107.0	283.2	2
30KPA70A	30KPA70CA	70.0	78.20~86.43	5	109.0	278.0	2
30KPA71A	30KPA71CA	71.0	79.30~87.65	5	111.5	271.7	2
30KPA72A	30KPA72CA	72.0	80.40~88.86	5	114.0	265.8	2
30KPA75A	30KPA75CA	75.0	83.80~92.62	5	119.4	253.8	2
30KPA78A	30KPA78CA	78.0	87.10~96.27	5	129.0	234.9	2
30KPA84A	30KPA84CA	84.0	93.80~103.67	5	139.2	217.7	2
30KPA90A	30KPA90CA	90.0	100.50~111.08	5	146.4	207.0	2
30KPA96A	30KPA96CA	96.0	107.20~118.48	5	156.0	194.2	2
30KPA102A	30KPA102CA	102.0	113.90~125.89	5	165.6	183.0	2
30KPA108A	30KPA108CA	108.0	120.60~133.29	5	175.2	172.9	2
30KPA120A	30KPA120CA	120.0	134.00~148.11	5	194.4	155.9	2
30KPA132A	30KPA132CA	132.0	147.40~162.92	5	213.0	142.3	2
30KPA144A	30KPA144CA	144.0	160.80~177.73	5	223.2	135.8	2
30KPA150A	30KPA150CA	150.0	167.60~185.24	5	233.4	129.8	2
30KPA156A	30KPA156CA	156.0	174.30~192.65	5	245.0	123.7	2
30KPA160A	30KPA160CA	160.0	178.70~197.51	5	252.6	120.0	2
30KPA168A	30KPA168CA	168.0	187.70~207.46	5	272.4	111.2	2
30KPA170A	30KPA170CA	170.0	189.90~209.89	5	275.0	110.2	2
30KPA180A	30KPA180CA	180.0	201.10~222.27	5	290.4	104.3	2
30KPA198A	30KPA198CA	198.0	221.20~244.48	5	319.8	94.7	2
30KPA216A	30KPA216CA	216.0	241.30~266.70	5	348.6	86.9	2
30KPA240A	30KPA240CA	240.0	268.10~296.32	5	387.0	78.3	2
30KPA258A	30KPA258CA	258.0	288.20~318.54	5	416.4	72.8	2
30KPA260A	30KPA260CA	260.0	290.40~320.97	5	416.0	72.8	2
30KPA270A	30KPA270CA	270.0	301.60~333.35	5	436.2	69.5	2
30KPA280A	30KPA280CA	280.0	312.80~345.73	5	464.0	65.3	2
30KPA288A	30KPA288CA	288.0	321.70~355.56	5	469.9	64.5	2

Notes: For bidirectional type having V_{RWM} of 60V and less, the I_R limit is double.

Ratings and Characteristic Curves ($T_A=25^\circ\text{C}$ unless otherwise noted)

Figure 1. Peak Pulse Power Rating Curve

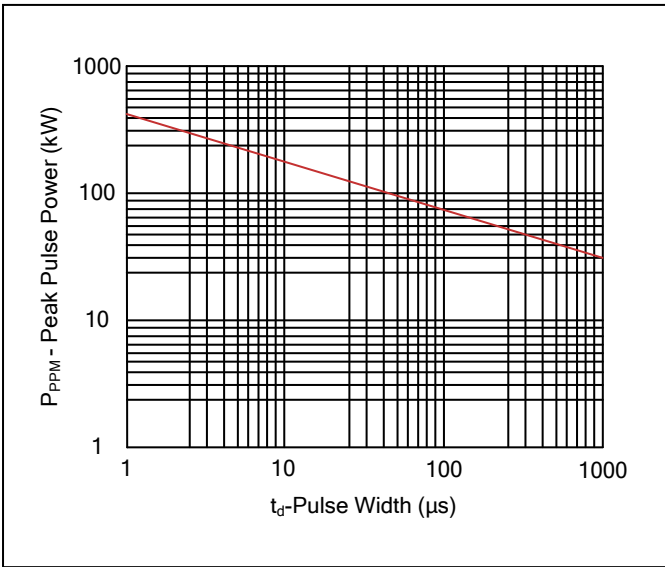

Figure 2. Pulse Derating Curve

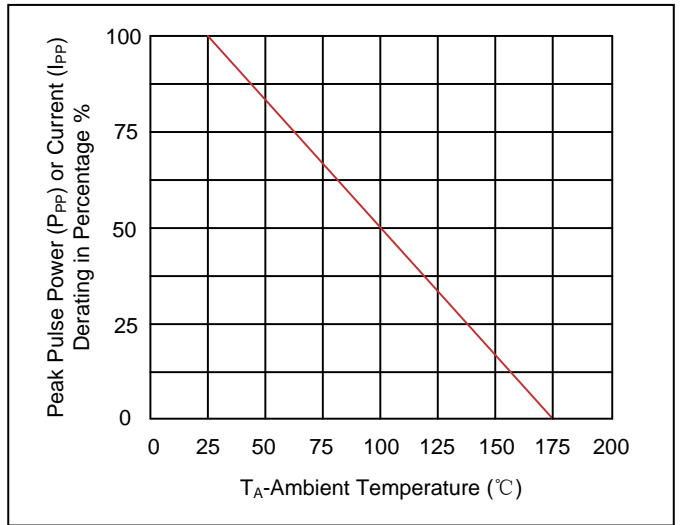

Figure 3. Pulse Waveform

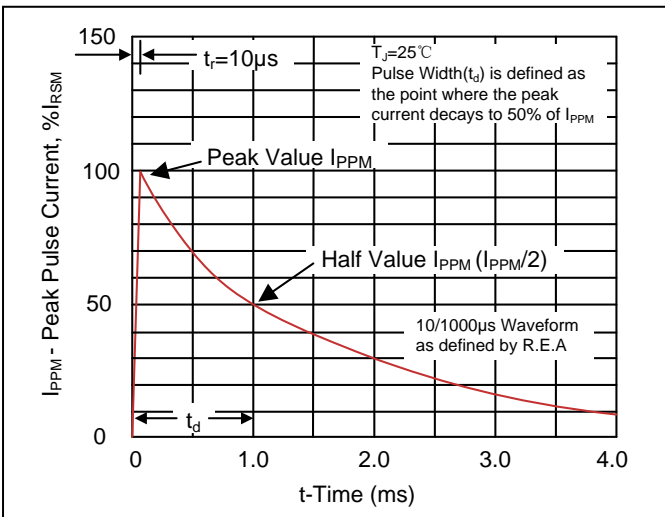

Figure 4. AC Line Protection Application

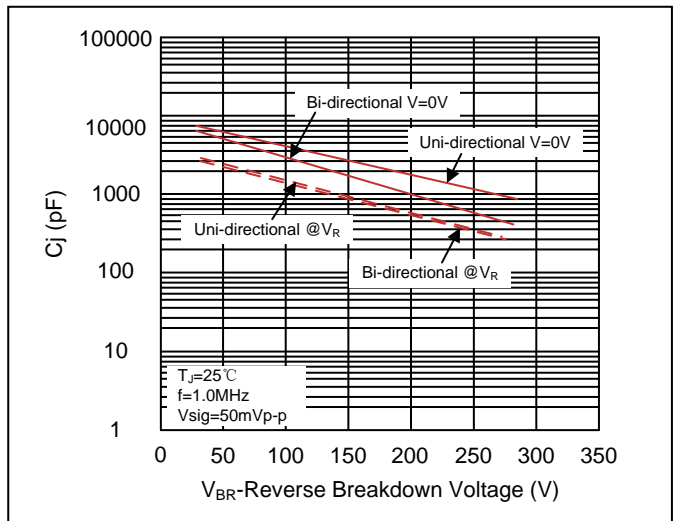

Figure 5. Steady State Power Dissipation Derating Curve

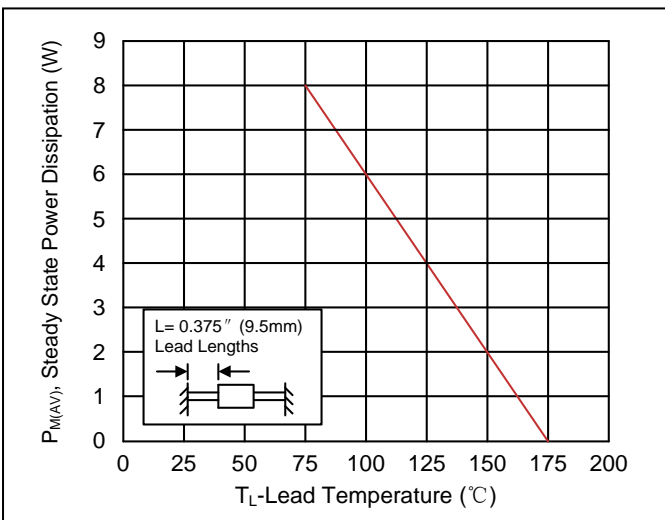
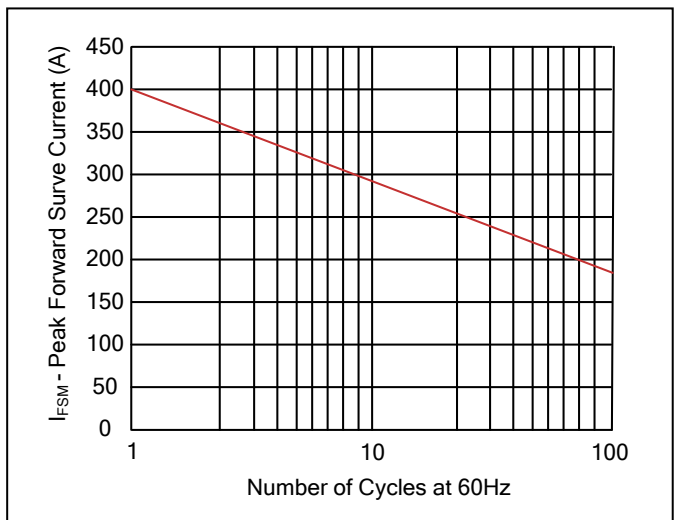
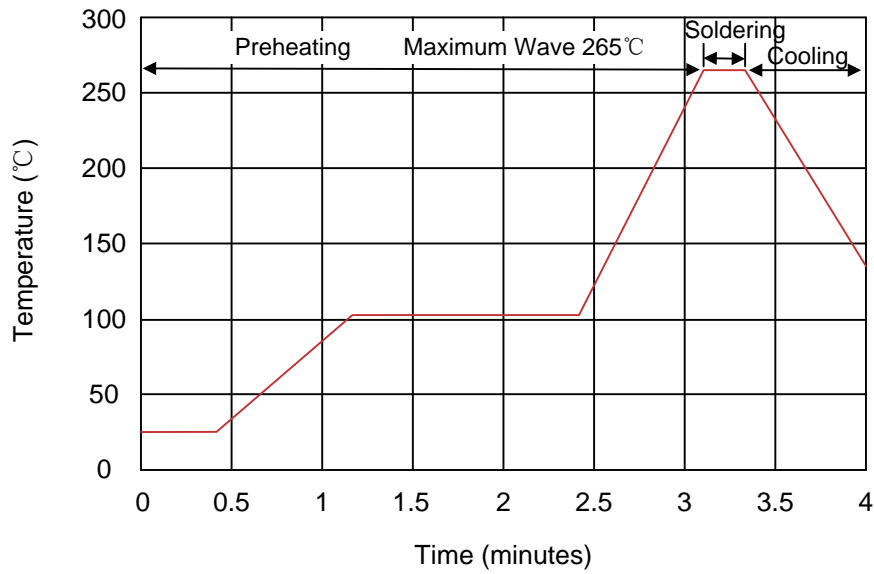

Figure 6. Maximum Non-Repetitive Forward Surge Current Uni-Directional Only



Recommended Soldering Conditions

Wave Soldering



Recommended Conditions

Item	Conditions
Peak Temperature	265°C
Dipping Time	10 seconds
Soldering	1 time

Marking Code

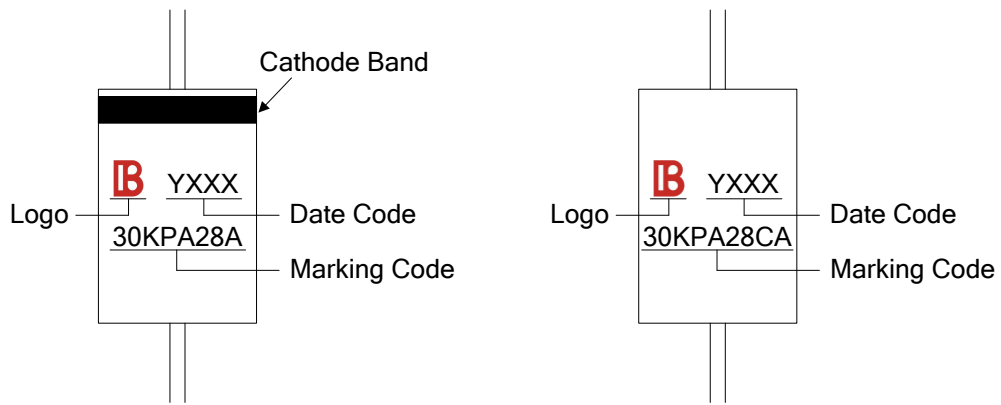

Packaging

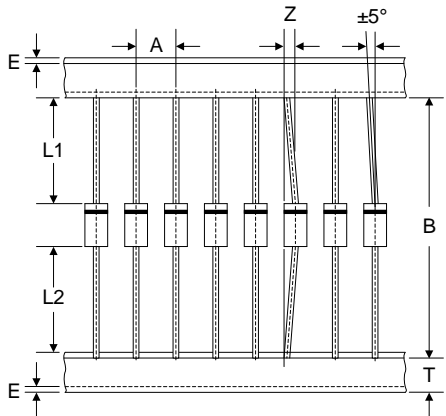
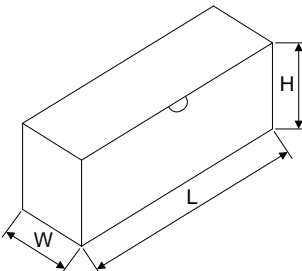
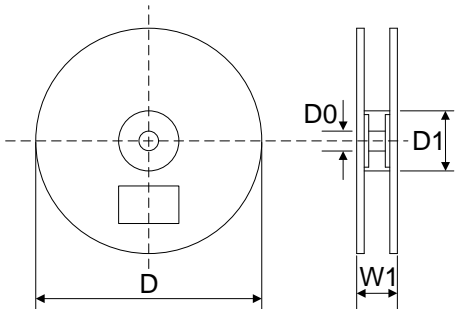
Tape	Symbol Dimension (mm)	
	A	10.0±0.5
	B	53.0±1.0
	Z	1.2Max.
	T	6.0±0.4
	E	0.8Max.
	L1-L2	1.0Max.
Box	L	250.0±5.0
	W	75.0±5.0
	H	114.0±5.0
	Quantity: 300PCS	
Reel	D	330.0±3.0
	D0	16.4±2.0
	D1	86.0±2.0
	W1	76.0±3.0
	Quantity: 800PCS	



Компания «ЭлектроПласт» предлагает заключение долгосрочных отношений при поставках импортных электронных компонентов на взаимовыгодных условиях!

Наши преимущества:

- Оперативные поставки широкого спектра электронных компонентов отечественного и импортного производства напрямую от производителей и с крупнейших мировых складов;
- Поставка более 17-ти миллионов наименований электронных компонентов;
- Поставка сложных, дефицитных, либо снятых с производства позиций;
- Оперативные сроки поставки под заказ (от 5 рабочих дней);
- Экспресс доставка в любую точку России;
- Техническая поддержка проекта, помощь в подборе аналогов, поставка прототипов;
- Система менеджмента качества сертифицирована по Международному стандарту ISO 9001;
- Лицензия ФСБ на осуществление работ с использованием сведений, составляющих государственную тайну;
- Поставка специализированных компонентов (Xilinx, Altera, Analog Devices, Intersil, Interpoint, Microsemi, Aeroflex, Peregrine, Syfer, Eurofarad, Texas Instrument, Miteq, Cobham, E2V, MA-COM, Hittite, Mini-Circuits, General Dynamics и др.);

Помимо этого, одним из направлений компании «ЭлектроПласт» является направление «Источники питания». Мы предлагаем Вам помощь Конструкторского отдела:

- Подбор оптимального решения, техническое обоснование при выборе компонента;
- Подбор аналогов;
- Консультации по применению компонента;
- Поставка образцов и прототипов;
- Техническая поддержка проекта;
- Защита от снятия компонента с производства.



Как с нами связаться

Телефон: 8 (812) 309 58 32 (многоканальный)

Факс: 8 (812) 320-02-42

Электронная почта: org@eplast1.ru

Адрес: 198099, г. Санкт-Петербург, ул. Калинина, дом 2, корпус 4, литера А.