

Slotted Optical Flag Switch

OPB850A, OPB850-1Z



Features:

- Snap into PCBoard mounting
- Transistor output
- Mechanical switch replacement
- Four 18" (457 mm) 26 AWG, UL wires for electrical connections
- Choice of phototransistor or Rbe phototransistor output

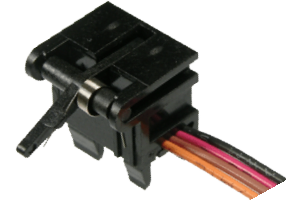

Description:

Each **OPB850A** switch has a NPN phototransistor coupled with a 940 nm gallium arsenide infrared emitting diode in a molded plastic housing. Each **OPB850-1Z** has a Rbe phototransistor coupled with an 880 nm gallium arsenide infrared emitting diode in a molded plastic housing. An actuated lever arm flag interrupts the light beam, which switches the transistor output between states that can readily drive logic gates.

These devices are designed to replace conventional mechanical limit switches where long life and reliability are critical. The switches are designed to easily snap mount into a 0.036 inch (0.914 mm) 20 gage thick material with a rectangular opening of 0.315" x 0.472 " (8.0 mm x 12.0 mm).

Minor differences exist in the package between the **OPB850A** and **OPB850-1Z** (see drawings below). The cable exits the package in different locations.

Custom electrical, wire and cabling and connectors are available. Contact your local representative or OPTEK for more information.

Applications:

- Non-contact interruptive object sensing
- Assembly line automation
- Machine automation
- Equipment security
- Machine safety

OPB850A, OPB850-1Z	
Pin # / Color	Description
1-Black	Emitter
2-Red	Anode
3-Brown	Collector
4-Orange	Cathode

Ordering Information		
Part Number	Wavelength	Description
OPB850A	940 nm	Slotted Optical Flag Switch 18" (457 mm) wires
OPB850-1Z	880 nm	Slotted Optical Flag Switch 18" (457 mm) wires

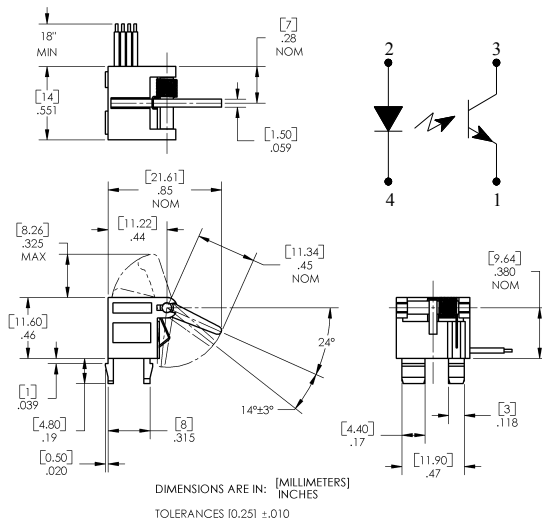

OPB850A

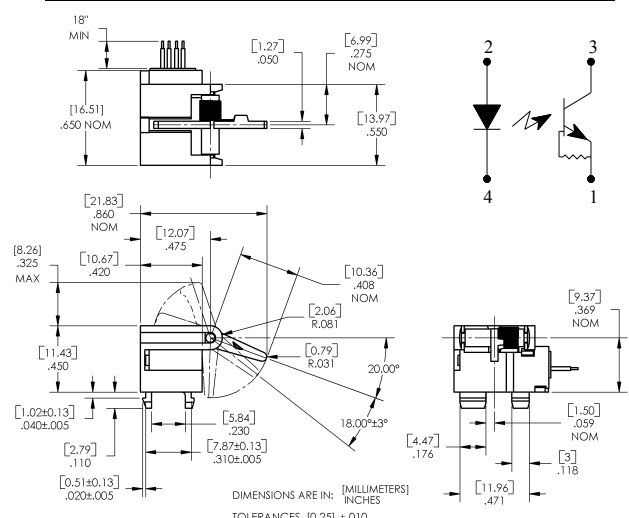

OPB850-1Z



General Note
TT Electronics reserves the right to make changes in product specification without notice or liability. All information is subject to TT Electronics' own data and is considered accurate at time of going to print.

OPTEK Technology, Inc.
1645 Wallace Drive, Carrollton, TX 75006
Ph: +1 972 323 2200
www.optekinc.com | www.ttelectronics.com

Slotted Optical Flag Switch

OPB850A, OPB850-1Z



Absolute Maximum Ratings ($T_A = 25^\circ\text{C}$ unless otherwise noted)

Operating Temperature Range	-20° C to +75° C
Storage Temperature Range	-40° C to +85° C
Lead Soldering Temperature [1/16 inch (1.6 mm) from the case for 5 sec. with soldering iron]	260° C
Input Diode	
Reverse Voltage	5 V
Continuous Forward Current	50 mA
Peak Forward Current (10 μs pulse width, 300 pps)	1 A
Power Dissipation	75 mW
Output Phototransistor	
Collector-Emitter Voltage	24 V
Emitter-Collector Voltage	5 V
Collector DC Current	20 mA
Power Dissipation	100 mW

General Note
TT Electronics reserves the right to make changes in product specification without notice or liability. All information is subject to TT Electronics' own data and is considered accurate at time of going to print.

OPTEK Technology, Inc.
1645 Wallace Drive, Carrollton, TX 75006 | Ph: +1 972 323 2200
www.optekinc.com | www.ttelectronics.com

Slotted Optical Flag Switch

OPB850A, OPB850-1Z



Electrical Characteristics ($T_A = 25^\circ\text{C}$ unless otherwise noted)

SYMBOL	PARAMETER	MIN	TYP	MAX	UNITS	TEST CONDITIONS
Input Diode						
V_F	Forward Voltage	-	1.2	1.6	V	$I_F = 20\text{ mA}$
I_R	Reverse Current	-	-	-	μA	$V_R = 2\text{ V}$
Output Phototransistor (OPB850A)						
$V_{(BR)CEO}$	Collector-Emitter Breakdown Voltage	30	-	-	V	$I_C = 100\ \mu\text{A}$, $E_E = 0$
$V_{(BR)ECO}$	Emitter-Collector Breakdown Voltage	5	-	-	V	$I_E = 100\ \mu\text{A}$, $E_E = 0$
I_{CEO}	Collector-Emitter Dark Current	-	-	100	nA	$V_{CE} = 10\text{ V}$, $E_E = 0$
Coupled (OPB850A)						
$V_{CE(SAT)}$	Collector-Emitter Saturation Voltage ⁽¹⁾	-	-	0.4	V	$I_C = 250\ \mu\text{A}$, $I_F = 20\text{ mA}$
$I_{C(ON)}$	On-State Collector Current ⁽¹⁾	0.5	2	-	mA	$V_{CE} = 5\text{ V}$, $I_F = 20\text{ mA}$
$I_{C(OFF)}$	Off-State Collector Current ⁽²⁾	-	-	10	μA	$V_{CE} = 5\text{ V}$, $I_F = 20\text{ mA}$
Output Phototransistor (OPB850-1Z)						
$V_{(BR)CEO}$	Collector-Emitter Breakdown Voltage	24	-	-	V	$I_C = 100\ \mu\text{A}$, $E_E = 0$
$V_{(BR)ECO}$	Emitter-Collector Breakdown Voltage	0.4	-	-	V	$I_E = 100\ \mu\text{A}$, $E_E = 0$
I_{CEO}	Collector-Emitter Dark Current	-	-	100	nA	$V_{CE} = 10\text{ V}$, $E_E = 0$
Coupled (OPB850-1Z)						
$V_{CE(SAT)}$	Collector-Emitter Saturation Voltage ⁽¹⁾	-	-	0.40	V	$I_C = 500\ \mu\text{A}$, $I_F = 20\text{ mA}$
$I_{C(ON)}$	On-State Collector Current ⁽¹⁾	0.5	2	-	mA	$V_{CE} = 10\text{ V}$, $I_F = 20\text{ mA}$
$I_{C(OFF)}$	Off-State Collector Current ⁽²⁾	-	-	10	μA	$V_{CE} = 10\text{ V}$, $I_F = 20\text{ mA}$

Notes:

- (1) ON ($I_{C(ON)}$) electrical condition corresponds to the switch point at about 41° angular displacement of the arm.
- (2) OFF ($I_{C(OFF)}$) electrical condition corresponds to the mechanical arm position at rest.
- (3) From the rest position to the switch point, lever torque measured at the end of the arm is 1.5 grams maximum.
- (4) Wires are 26 AWG, UL rated.



Компания «ЭлектроПласт» предлагает заключение долгосрочных отношений при поставках импортных электронных компонентов на взаимовыгодных условиях!

Наши преимущества:

- Оперативные поставки широкого спектра электронных компонентов отечественного и импортного производства напрямую от производителей и с крупнейших мировых складов;
- Поставка более 17-ти миллионов наименований электронных компонентов;
- Поставка сложных, дефицитных, либо снятых с производства позиций;
- Оперативные сроки поставки под заказ (от 5 рабочих дней);
- Экспресс доставка в любую точку России;
- Техническая поддержка проекта, помощь в подборе аналогов, поставка прототипов;
- Система менеджмента качества сертифицирована по Международному стандарту ISO 9001;
- Лицензия ФСБ на осуществление работ с использованием сведений, составляющих государственную тайну;
- Поставка специализированных компонентов (Xilinx, Altera, Analog Devices, Intersil, Interpoint, Microsemi, Aeroflex, Peregrine, Syfer, Eurofarad, Texas Instrument, Miteq, Cobham, E2V, MA-COM, Hittite, Mini-Circuits, General Dynamics и др.);

Помимо этого, одним из направлений компании «ЭлектроПласт» является направление «Источники питания». Мы предлагаем Вам помощь Конструкторского отдела:

- Подбор оптимального решения, техническое обоснование при выборе компонента;
- Подбор аналогов;
- Консультации по применению компонента;
- Поставка образцов и прототипов;
- Техническая поддержка проекта;
- Защита от снятия компонента с производства.



Как с нами связаться

Телефон: 8 (812) 309 58 32 (многоканальный)

Факс: 8 (812) 320-02-42

Электронная почта: org@eplast1.ru

Адрес: 198099, г. Санкт-Петербург, ул. Калинина, дом 2, корпус 4, литера А.