

### Description

The EP5348UI delivers the optimal trade-off between footprint and efficiency. It is a perfect alternative to replace less efficient LDOs in space constrained applications that require improved efficiency.

The EP5348UI is a 400mA PowerSoC which integrates MOSFET switches, control, compensation, and the magnetics in a micro-QFN Package. This highly integrated DCDC solution offers up to 46-points better efficiency than the comparable LDO. A significant reduction in power loss and improved thermals are achieved. It enables extended battery life and helps Meet Energy Star requirements.

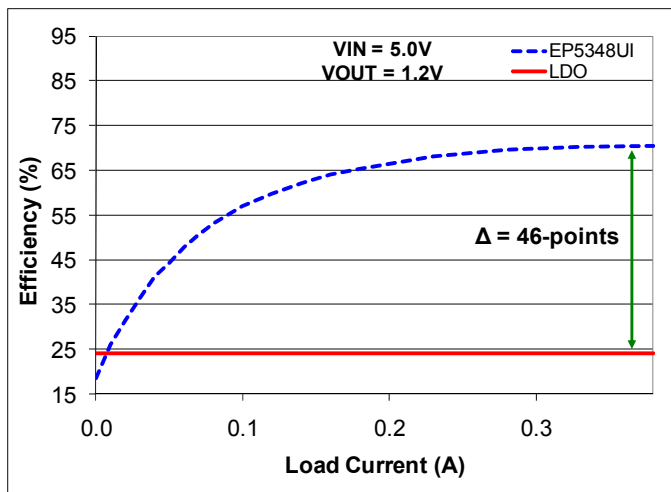

Integrated magnetics enables a tiny solution footprint, low output ripple, and high reliability, while maintaining high efficiency. The complete solution size is similar to an LDO and much smaller than a comparable DCDC.

### Features

- Integrated Inductor Technology
- 400mA continuous output current
- 2.0mm x 1.75mm x 0.9mm uQFN package
- Small Solution Footprint
- Efficiency, up to 90%
- $V_{OUT}$  Range 0.6V to  $V_{IN} - V_{DROP\_OUT}$
- Short circuit and over current protection
- UVLO and thermal protection
- IC level reliability in a PowerSoC solution

### Applications

- Applications where poor LDO efficiency creates:
  - Thermal challenges
  - Battery Life challenges
  - Failure to meet Energy Star requirements
- Space-constrained applications
- Portable media players and USB peripherals

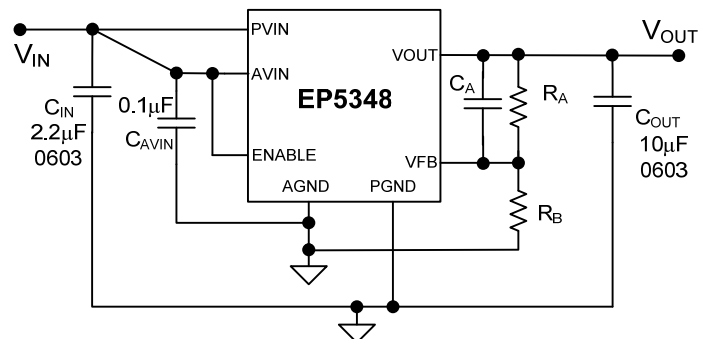

Figure 1: Typical Application Schematic

## Ordering Information

## Pin Assignments (Top View)

Part Number	Package
EP5348UI	14-pin $\mu$ QFN T&R
EP5348UI-E	EP5348UI Evaluation Board

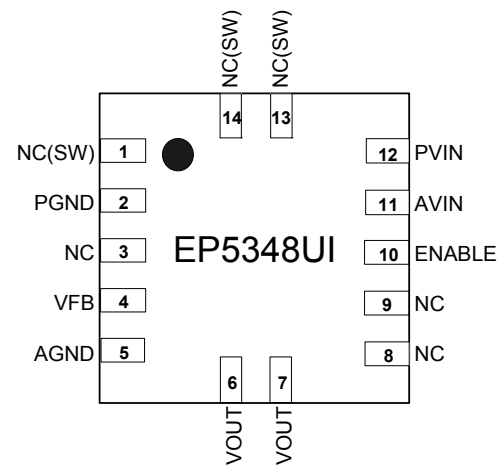

Figure 2: EP5348UI Pin Out Diagram (Top View)

## Pin Description

PIN	NAME	FUNCTION
1, 13, 14	NC(SW)	NO CONNECT – These pins are internally connected to the common switching node of the internal MOSFETs. NC (SW) pins are not to be electrically connected to any external signal, ground, or voltage. However, they must be soldered to the PCB. Failure to follow this guideline may result in part malfunction or damage to the device.
2	PGND	Power ground. Connect this pin to the ground electrode of the Input and output filter capacitors.
3, 8, 9	NC	NO CONNECT: These pins may already be connected inside the device. Therefore, they cannot be electrically connected to each other or to any external signal, voltage, or ground. They must however be soldered to the PCB. Failure to follow this guideline may result in device damage.
4	VFB	Feedback pin for external voltage divider network.
5	AGND	Analog ground. This is the quiet ground for the internal control circuitry, and the ground return for external feedback voltage divider
6, 7	VOUT	Regulated Output Voltage. Refer to application section for proper layout and decoupling.
10	ENABLE	Output Enable. Enable = logic high; Disable = logic low
11	AVIN	Input power supply for the controller circuitry. Connect to VIN at a quiet point.
12	PVIN	Input Voltage for the MOSFET switches.

## Absolute Maximum Ratings

**CAUTION:** Absolute Maximum ratings are stress ratings only. Functional operation beyond the recommended operating conditions is not implied. Stress beyond the absolute maximum ratings may cause permanent damage to the device. Exposure to absolute maximum rated conditions for extended periods may affect device reliability.

PARAMETER	SYMBOL	MIN	MAX	UNITS
<b>Absolute Maximum Electrical Ratings</b>				
Supply Voltage – PVIN, AVIN, VOUT	$V_{IN}$	-0.3	6.0	V
Voltage on ENABLE		-0.3	$V_{IN} + 0.3$	V
Voltage on $V_{FB}$		-0.3	2.7	V
ESD Rating (based on Human Body Mode)			2000	V
ESD Rating (Charge Device Model)		500		V
<b>Absolute Maximum Thermal Ratings</b>				
Maximum Operating Junction Temperature	$T_{J-ABS}$		150	°C
Storage Temperature Range	$T_{STG}$	-65	150	°C
Reflow Temp, 10 Sec, MSL3 JEDEC J-STD-020C			260	°C

## Recommended Operating Conditions

PARAMETER	SYMBOL	MIN	MAX	UNITS
Input Voltage Range	$V_{IN}$	2.5	5.5	V
Output Voltage Range	$V_{OUT}$	0.6	$V_{IN} - V_{DO}^{\dagger}$	V
Operating Ambient Temperature	$T_A$	-40	+85	°C
Operating Junction Temperature	$T_J$	-40	+125	°C

<sup>†</sup>  $V_{DO}$  (drop-out voltage) is defined as ( $I_{LOAD} \times \text{Dropout Resistance}$ ). Please see the EC Table.

## Thermal Characteristics

PARAMETER	SYMBOL	TYP	UNITS
Thermal Shutdown Trip Point	$T_{J-TP}$	+155	°C
Thermal Shutdown Trip Point Hysteresis		15	°C
Thermal Resistance: Junction to Ambient –0 LFM ( <b>Note 1</b> )	$\theta_{JA}$	105	°C/W

**Note 1:** Based on 2 oz. external copper layers and proper thermal design in line with EIA/JEDEC JESD51-7 standard for high effective thermal conductivity boards.

## Electrical Characteristics

NOTE:  $T_A = -40^{\circ}\text{C}$  to  $+85^{\circ}\text{C}$  unless otherwise noted. Typical values are at  $T_A = 25^{\circ}\text{C}$ ,  $V_{IN} = 3.6\text{V}$ .  
 $C_{IN} = 2.2\mu\text{F}$  0603 MLCC,  $C_{OUT} = 10\mu\text{F}$  0603.

PARAMETER	SYMBOL	TEST CONDITIONS	MIN	TYP	MAX	UNITS
Operating Input Voltage Range	$V_{IN}$		2.5		5.5	V
Under Voltage Lock-out – $V_{IN}$ Rising	$V_{UVLO\_R}$			2.3		V
Under Voltage Lock-out – $V_{IN}$ Falling	$V_{UVLO\_F}$			2.2		V
Shut-down Supply Current	$I_{SD}$	Enable = Low		3		$\mu\text{A}$
VFB Voltage Initial Accuracy	$V_{FB}$	$T_A = 25^{\circ}\text{C}$ , $V_{IN} = 3.6\text{V}$ ; $I_{LOAD} = 100\text{mA}$ ; $0.8\text{V} \leq V_{OUT} \leq 3.3\text{V}$	0.588	0.600	0.612	V
Line Regulation	$\Delta V_{OUT\_LINE}$	$2.5\text{V} \leq V_{IN} \leq 5.5\text{V}$		0.03		%/V
Load Regulation	$\Delta V_{OUT\_LOAD}$	$0\text{A} \leq I_{LOAD} \leq 400\text{Ma}$		0.48		%/A
Temperature Variation	$\Delta V_{OUT\_TEMPL}$	$-40^{\circ}\text{C} \leq T_A \leq +85^{\circ}\text{C}$		24		ppm/ $^{\circ}\text{C}$
Feedback Pin Input Current	$I_{FB}$	Note 1		<300		nA
Output Current	$I_{OUT}$		0		400	mA
OCP Threshold	$I_{LIM}$	$2.5\text{V} \leq V_{IN} \leq 5.5\text{V}$ $0.6\text{V} \leq V_{OUT} \leq 3.3\text{V}$		1.4		A
Output Dropout Resistance (Note 1) Voltage (Note 1,2)	$R_{DO}$ $V_{DO\_FL}$	Input to Output Resistance $V_{INMIN} - V_{OUT}$ at Full load		520 208	780 312	m $\Omega$ mV
Operating Output Voltage Range	$V_{OUT}$	$V_{DO} = I_{OUT} * R_{DO}$	0.6		$V_{IN} - V_{DO}$	V
Enable Pin Logic Low	$V_{ENLO}$				0.3	V
Enable Pin Logic High	$V_{ENHI}$		1.4			V
Enable Pin Current	$I_{ENABLE}$	Note 1		<200		nA
Operating Frequency	$F_{OSC}$			9		MHz
<b>Soft Start Operation</b>						
$V_{OUT}$ Rise Time	$T_{RISE}$	From 0 to full output voltage	1.17	1.8	2.43	mSec

**Notes:** 1 - Parameter guaranteed by design  
 2 -  $V_{DO\_FL}$  (full-load drop-out voltage) is defined as (Maximum  $I_{OUT}$  x Dropout Resistance)

# Typical Performance Characteristics

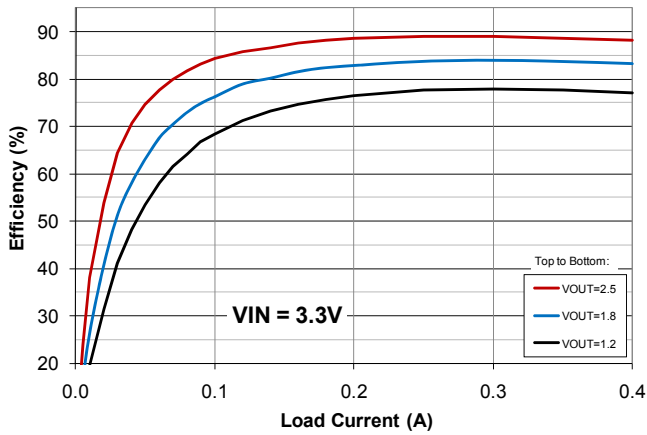

Efficiency vs. Load Current:  $V_{IN} = 3.3V$ ,  $V_{OUT}$  (from top to bottom) = 2.5, 1.8, 1.2V

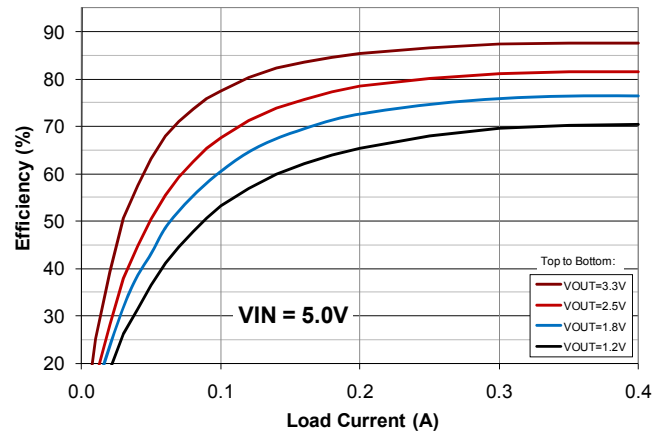

Efficiency vs. Load Current:  $V_{IN} = 5.0V$ ,  $V_{OUT}$  (from top to bottom) = 3.3, 2.5, 1.2V

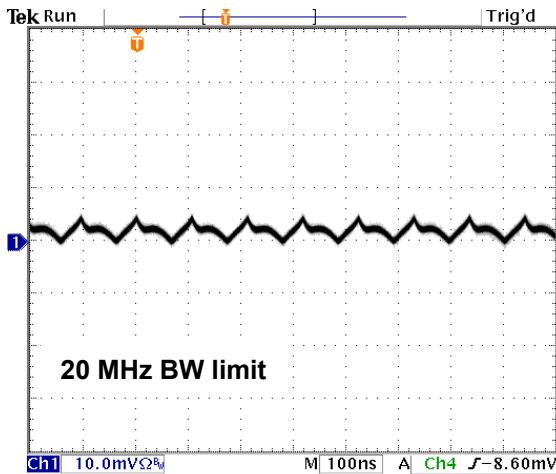

Output Ripple:  $V_{IN} = 3.3V$ ,  $V_{OUT} = 1.0V$ ,  $I_{out} = 400mA$   
 $C_{IN} = 2.2\mu F/0603$ ,  $C_{OUT} = 10\mu F/0603 + 2.2\mu F/0603$

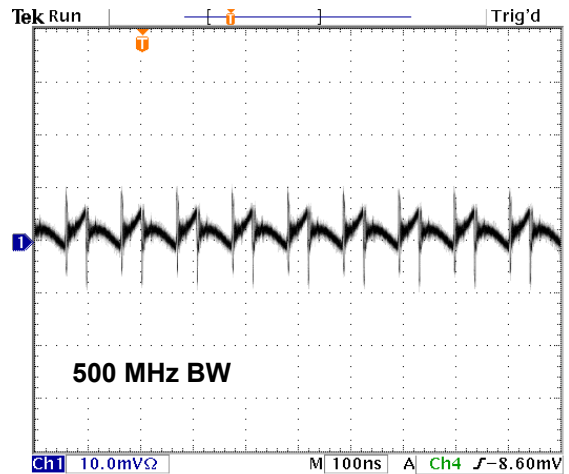

Output Ripple:  $V_{IN} = 3.3V$ ,  $V_{OUT} = 1.0V$ ,  $I_{out} = 400mA$   
 $C_{IN} = 2.2\mu F/0603$ ,  $C_{OUT} = 10\mu F/0603 + 2.2\mu F/0603$

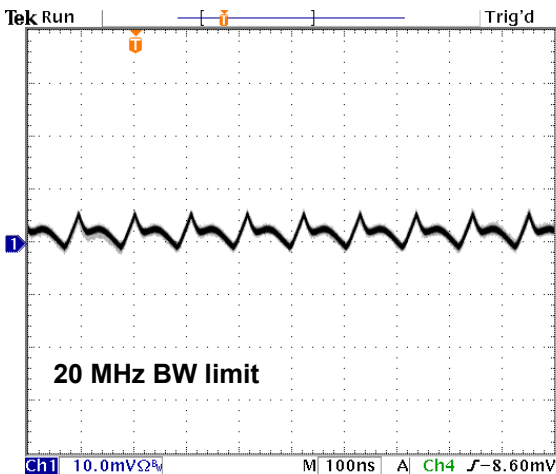

Output Ripple:  $V_{IN} = 5V$ ,  $V_{OUT} = 1.0V$ ,  $I_{out} = 400mA$   
 $C_{IN} = 2.2\mu F/0603$ ,  $C_{OUT} = 10\mu F/0603 + 2.2\mu F/0603$

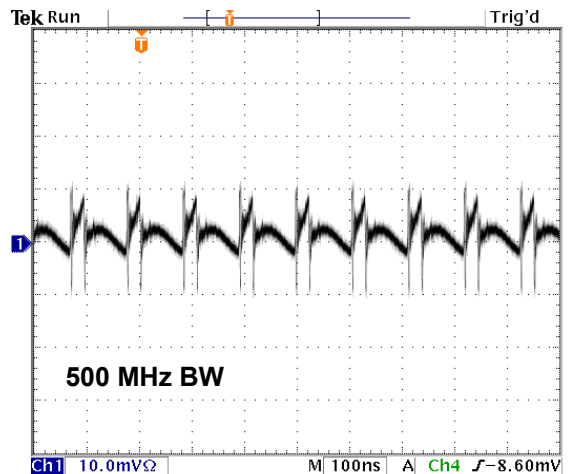

Output Ripple:  $V_{IN} = 5V$ ,  $V_{OUT} = 1.0V$ ,  $I_{out} = 400mA$   
 $C_{IN} = 2.2\mu F/0603$ ,  $C_{OUT} = 10\mu F/0603 + 2.2\mu F/0603$

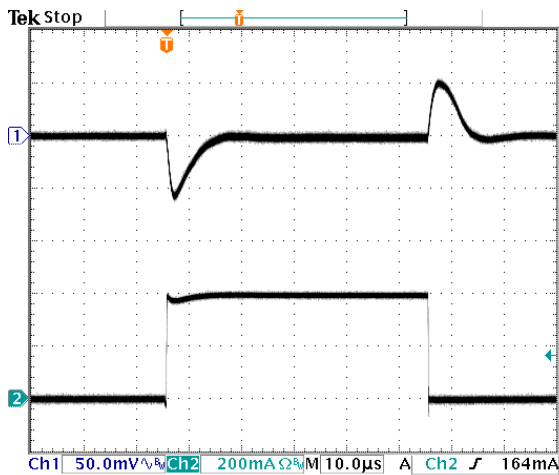

**Load Transient:  $V_{IN} = 3.3V$ ,  $V_{OUT} = 1.0V$**   
**Ch.1:  $V_{OUT}$ , Ch.2:  $I_{LOAD} 0 \leftrightarrow 400mA$**   
 $C_{IN} = 2.2\mu F/0603$ ,  $C_{OUT} = 10\mu F/0603 + 2.2\mu F/0603$

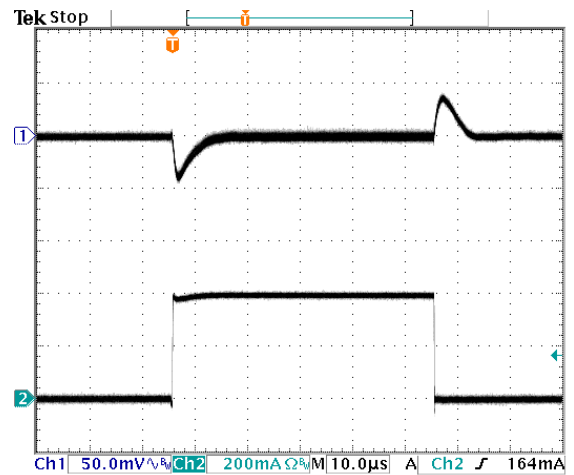

**Load Transient:  $V_{IN} = 5V$ ,  $V_{OUT} = 1.0V$**   
**Ch.1:  $V_{OUT}$ , Ch.2:  $I_{LOAD} 0 \leftrightarrow 400mA$**   
 $C_{IN} = 2.2\mu F/0603$ ,  $C_{OUT} = 10\mu F/0603 + 2.2\mu F/0603$

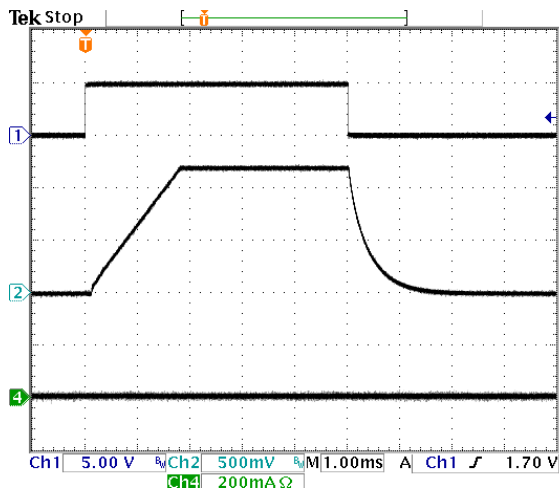

**Power Up/Down at No Load:  $V_{IN}/V_{OUT} = 5.0V/1.2V$ ,**  
 $C_{out} \approx 10\mu F$ , Ch.1: ENABLE, Ch. 2:  $V_{OUT}$ , Ch.4:  $I_{OUT}$

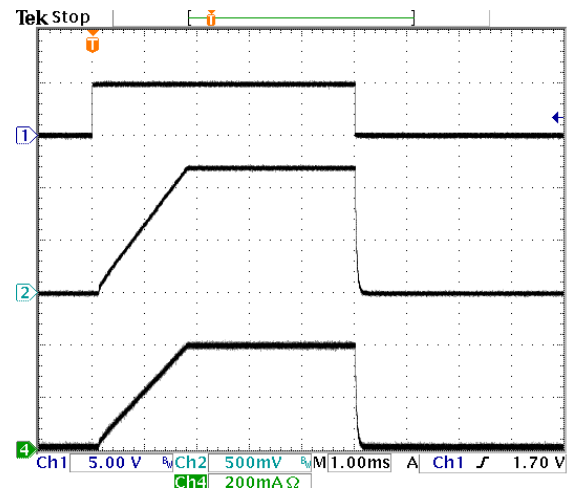

**Power Up/Down into 3Ω load:  $V_{IN}/V_{OUT} = 5.5V/3.3V$ ,**  
 $C_{out} \approx 10\mu F$ , Ch.1: ENABLE, Ch. 2:  $V_{OUT}$ , Ch.4:  $I_{OUT}$

## Detailed Description

### Functional Overview

The EP5348UI requires only 2 small MLCC capacitors and a few small-signal components for a complete DC-DC converter solution. The device integrates MOSFET switches, PWM controller, Gate-drive, part of the loop compensation, and inductor into a tiny 2.0mm x 1.75mm x 0.9mm micro-QFN package. Advanced package design, along with the high level of integration, provides very low output ripple and noise. The EP5348UI uses voltage mode control for high noise immunity and load matching to advanced  $\leq 90\text{nm}$  loads. An external resistor divider is used to program output setting over the 0.6V to  $V_{\text{IN}} - V_{\text{DROPOUT}}$  as specified in the Electrical Characteristics Table. The EP5348UI provides the industry's highest power density of any 400mA DC-DC converter solution.

The key enabler of this revolutionary integration is Enpirion's proprietary power MOSFET technology. The advanced MOSFET switches are implemented in deep-submicron CMOS to supply very low switching loss at high switching frequencies and to allow a high level of integration. The semiconductor process allows seamless integration of all switching, control, and compensation circuitry.

The proprietary magnetics design provides high-density/high-value magnetics in a very small footprint. Enpirion magnetics are carefully matched to the control and compensation circuitry yielding an optimal solution with assured performance over the entire operating range.

Protection features include under-voltage lock-out (UVLO), over-current protection (OCP), short circuit protection, and thermal overload protection.

### Integrated Inductor

The EP5348UI utilizes a proprietary low loss integrated inductor. The integration of the inductor greatly simplifies the power supply design process. The inherent shielding and compact construction of the integrated inductor reduces the noise that can couple into the

traces of the printed circuit board. Further, the package layout is optimized to reduce the electrical path length for the high di/dT currents that are always present in DC-DC converters. The integrated inductor provides the optimal solution to the complexity, output ripple, and noise that plague low power DC-DC converter design.

### Control Matched to sub 90nm Loads

The EP5348UI utilizes a type III compensation network. Voltage mode control is inherently impedance matched to the sub 90nm process technology that is used in today's advanced ICs. Voltage mode control also provides a high degree of noise immunity at light load currents so that low ripple and high accuracy are maintained over the entire load range. The very high switching frequency allows for a very wide control loop bandwidth and hence excellent transient performance.

### Soft Start

Internal soft start circuits limit the rate of output voltage rise when the device starts up from a power down condition, or when the "ENABLE" pin is asserted "high". Digital control circuitry controls the  $V_{\text{OUT}}$  rise time to ensure a smooth turn-on ramp.

The EP5348UI has a fixed  $V_{\text{OUT}}$  turn-on time. Therefore, the ramp rate will vary with the output voltage setting. Output voltage rise time is given in the Electrical Characteristics Table.

Excess bulk capacitance on the output of the device can cause an over-current condition at startup. The maximum total capacitance on the output, including the output filter capacitor, and bulk and decoupling capacitance at the load, is given as:

$$C_{\text{OUT\_TOTAL\_MAX}} = 9.333 \times 10^{-4} / V_{\text{OUT}}$$

The nominal value for the output filter capacitor is 10uF. See the applications section for more details.

### Over Current/Short Circuit Protection

The current limit function is achieved by sensing the current flowing through a sense P-



MOSFET which is compared to a reference current. When this level is exceeded the P-FET is turned off and the N-FET is turned on, pulling  $V_{OUT}$  low. This condition is maintained for approximately 0.5mS and then a normal soft start is initiated. If the over current condition still persists, this cycle will repeat.

### Under Voltage Lockout

During initial power up an under voltage lockout circuit will hold-off the switching circuitry until the input voltage reaches a sufficient level to ensure proper operation. If the voltage drops below the UVLO threshold, the lockout circuitry will disable the switching. Hysteresis is included to prevent chattering between states.

### Enable

The ENABLE pin provides a means to shut down the converter or enable normal operation. A logic low will disable the converter and cause it to shut down. A logic high will enable the converter into normal operation.

**NOTE:** The ENABLE pin must not be left floating.

### Thermal Shutdown

When excessive power is dissipated in the chip, the junction temperature rises. Once the junction temperature exceeds the thermal shutdown threshold, the thermal shutdown circuit turns off the converter output voltage thus allowing the device to cool. When the junction temperature decreases by 15C°, the device will go through the normal startup process.

## Application Information

### Output Voltage Programming

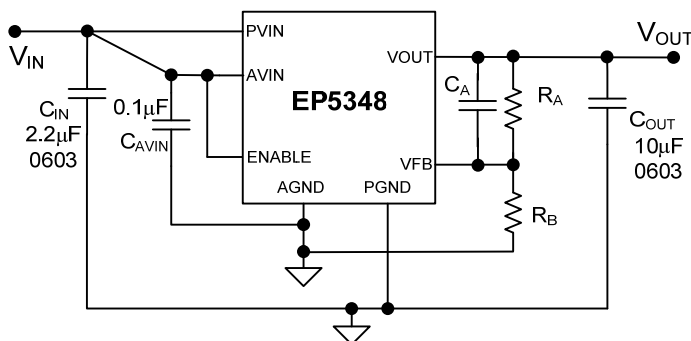

Figure 3: Typical Application Circuit

The EP5348UI uses a simple resistor divider to program the output voltage.

Referring to Figure 3, use 200 kΩ, 1% or better for the upper resistor ( $R_A$ ). The value of the bottom resistor ( $R_B$ ) in kΩ is given as:

$$R_B = \frac{V_{FB} * R_A}{(V_{OUT} - V_{FB})} \quad V_{FB} = 0.6V \text{ nominal}$$

A 5pF MLCC capacitor  $C_A$  is also required in parallel with  $R_A$  for compensation.

### Input Filter Capacitor

$C_{IN\_MIN} = 2.2\mu\text{F}$  0603 case size or larger.

The input capacitor must use a X5R or X7R or equivalent dielectric formulation. Y5V or equivalent dielectric formulations lose capacitance with frequency, bias, and with temperature, and are not suitable for switch-mode DC-DC converter input filter applications.

### Output Filter Capacitor

$C_{OUT\_MIN} = 10\mu\text{F}$  0603 + 2.2µF 0603 MLCC when  $4.5V \leq V_{IN} \leq 5.5V$ , **AND**  $I_{OUT} > 300\text{mA}$ .

$C_{OUT\_MIN} = 10\mu\text{F}$  0603 MLCC for all other use cases. However, ripple performance can always be improved by adding a second 2.2µF or 1µF output capacitor for any operating condition.

$V_{OUT}$  has to be sensed at the last output filter capacitor next to the EP5348UI. Any additional bulk capacitance for load decoupling and bypass has to be far enough from the  $V_{OUT}$



sensing point so that it does not interfere with the control loop operation. Excess total capacitance on the output (Output Filter + Bulk) can cause an over-current condition at startup. Please see the Soft Start section under Functional Overview for the maximum allowable bulk capacitance on the output rail.

The output capacitor must use a X5R or X7R or equivalent dielectric formulation. Y5V or equivalent dielectric formulations lose capacitance with frequency, bias, and temperature and are not suitable for switch-mode DC-DC converter output filter applications.

### LDO Replacement

The Enpirion EP5348UI is a suitable replacement for inefficient LDOs and can be used to augment the LDOs in a PMU with minimum footprint impact. This integrated DCDC solution offers significantly better efficiency, and significant reduction in power loss. The resulting improved thermals and extended battery life helps meet Energy Star

requirements. The total solution size is 25% smaller than a comparable LDO and half the footprint of a comparable DCDC.

As the table below shows, EP5348UI provides the optimal trade-off between footprint and efficiency when compared to a traditional LDO:

VIN (V)	VOUT (V)	LOAD (mA)	EFF DCDC	EFF LDO	PLOSS DCDC (mW)	PLOSS LDO (mW)	Power Saved (mW)
5.0	1.2	400	70.4%	24.0%	202	1520	1318
5.0	1.8	400	76.4%	36.0%	222	1280	1058
5.0	2.5	400	81.6%	50.0%	225	1000	775
5.0	3.3	400	87.7%	66.0%	185	680	495
3.3	1.2	400	77.1%	36.4%	143	840	697
3.3	1.8	400	83.3%	54.5%	144	600	456
3.3	2.5	400	88.2%	75.8%	134	320	186

### Power-Up Sequencing

During power-up, ENABLE should not be asserted before PVIN, and PVIN should not be asserted before AVIN. Tying all three pins together meets these requirements.

## Layout Recommendations

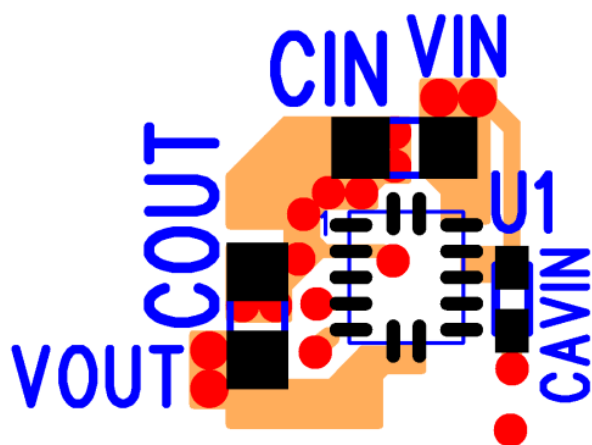

Figure 4: Top PCB Layer Critical Components and Copper for Minimum Footprint

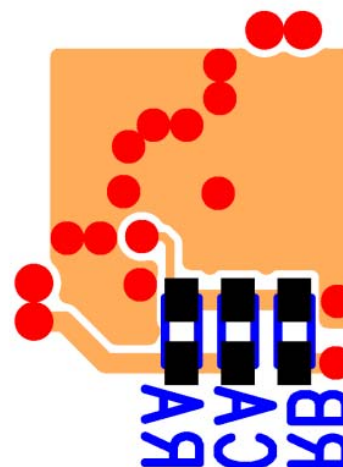

Figure 5: Bottom PCB Layer Critical Components (RA, RB, CA) & Copper for Minimum Footprint

Figures 4 and 5 show critical PCB top and bottom layer components and traces for a minimum-footprint recommended EP5348 layout with ENABLE tied to  $V_{IN}$ . Alternate ENABLE configurations need to be connected and routed according to specific customer application. This layout consists of four layers. For the other 2 layers and the exact dimensions, please see the Gerber files at [www.enpirion.com](http://www.enpirion.com). The recommendations given below are general guidelines. Customers may need to adjust these according to their own layout and manufacturing rules.

**Recommendation 1:** Input and output filter capacitors should be placed on the same side of the PCB, and as close to the EP5348UI package as possible. They should be connected to the device with very short and wide traces. Do not use thermal reliefs or spokes when connecting the capacitor pads to the respective nodes. The +V and GND traces between the capacitors and the EP5348UI should be as close to each other as possible so that the gap between the two nodes is minimized, even under the capacitors.

**Recommendation 2:** The system ground plane should be the first layer immediately below the surface layer. This ground plane should be continuous and un-interrupted below the converter and the input/output capacitors. Please the Gerber files at [www.enpirion.com](http://www.enpirion.com).

**Recommendation 3:** Multiple small vias should be used to connect ground terminal of the input capacitor and output capacitors to the system ground plane. It is preferred to put these vias along the edge of the GND copper closest to the +V copper. These vias connect the input/output filter capacitors to the GND plane, and help reduce parasitic inductances in the input and output current loops. See Figure

4. If the two vias cannot be put under  $C_{IN}$  or  $C_{OUT}$ , then put two vias right after the capacitors next the  $V_{IN}$  and  $V_{OUT}$  vias.

**Recommendation 4:** As Figure 5 shows,  $R_A$ ,  $R_B$ , and  $C_A$  have been placed on the back side to minimize the footprint. These components also need to be close to the VFB pin (see Figures 3, 4 and 5). The VFB pin is a high-impedance, sensitive node. Keep any trace connected to this node as short and thin as possible. Whenever possible, connect  $R_B$  directly to the AGND pin instead of going through the GND plane. In the layout shown above,  $R_B$  goes to the via next to AGND pin using a dedicated trace on layer 3 not shown here. See Gerber files at [www.enpirion.com](http://www.enpirion.com).

**Recommendation 5:** AVIN is the power supply for the small-signal control circuits. It should be connected to the input voltage at a quiet point. In Figure 4 this connection is made at the vias just before  $C_{IN}$ . There is an additional decoupling capacitor  $C_{AVIN}$  for AVIN which is connected between the device pin and the GND plane.

**Recommendation 6:** The via to the right of pin 2 underneath the device helps to minimize the parasitic inductances in the input and output loop ground connections.

**Recommendation 7:** The top layer 1 metal under the device must not be more than shown in Figure 4. As with any switch-mode DC/DC converter, try not to run sensitive signal or control lines underneath the converter package on other layers.

**Recommendation 8:** The  $V_{OUT}$  sense point should be just after the last output filter capacitor. Keep the sense trace short in order to avoid noise coupling into the node.

Recommended PCB Footprint

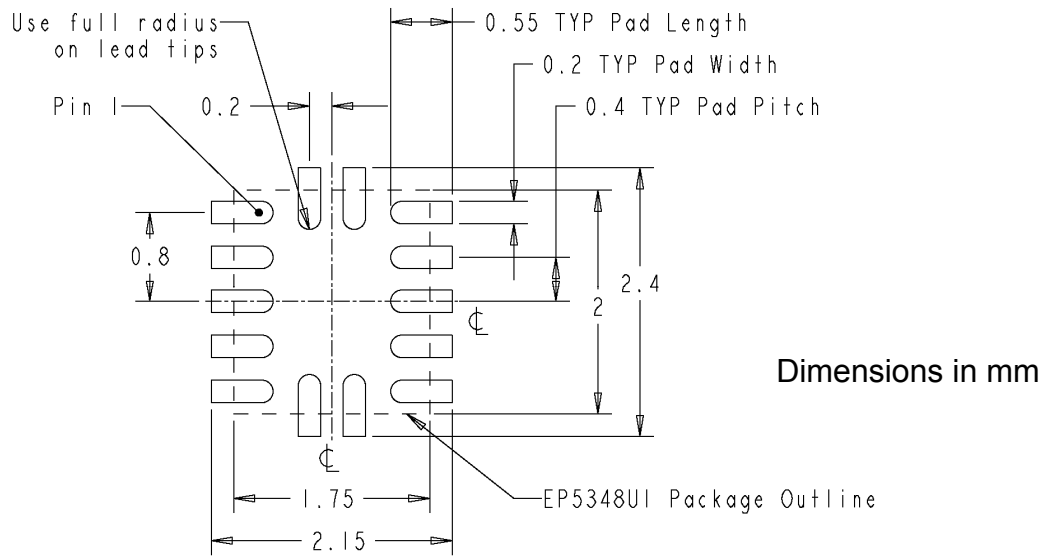

Figure 6: EN5348UI Package PCB Footprint

Package and Mechanical

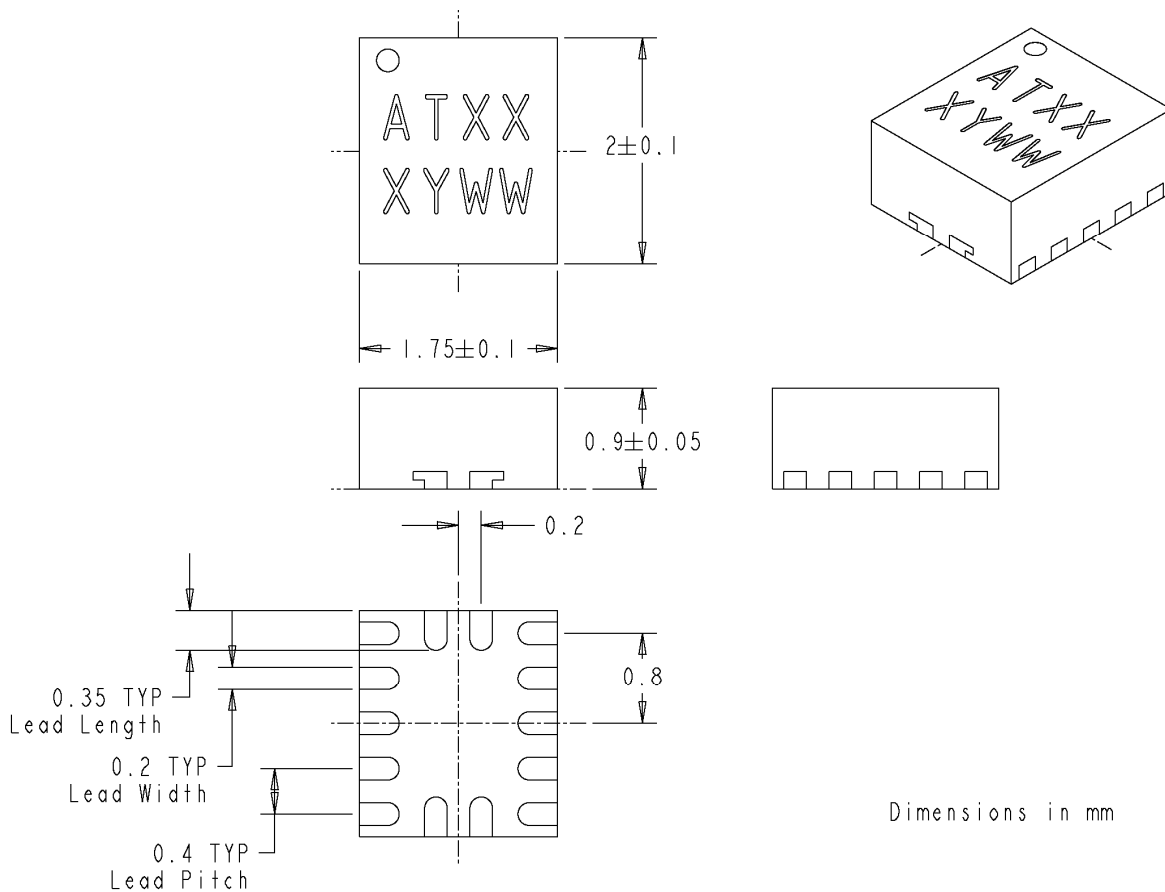

Figure 7 EN5348UI Package Dimensions

## Contact Information

Enpirion, Inc.  
Perryville III Corporate Park  
53 Frontage Road, Suite 210  
Hampton, NJ 08827  
Phone: +1 908-894-6000  
Fax: +1 908-894-6090  
[www.enpirion.com](http://www.enpirion.com)

Enpirion reserves the right to make changes in circuit design and/or specifications at any time without notice. Information furnished by Enpirion is believed to be accurate and reliable. Enpirion assumes no responsibility for its use or for infringement of patents or other third party rights, which may result from its use. Enpirion products are not authorized for use in nuclear control systems, as critical components in life support systems or equipment used in hazardous environment without the express written authority from Enpirion.



Компания «ЭлектроПласт» предлагает заключение долгосрочных отношений при поставках импортных электронных компонентов на взаимовыгодных условиях!

Наши преимущества:

- Оперативные поставки широкого спектра электронных компонентов отечественного и импортного производства напрямую от производителей и с крупнейших мировых складов;
- Поставка более 17-ти миллионов наименований электронных компонентов;
- Поставка сложных, дефицитных, либо снятых с производства позиций;
- Оперативные сроки поставки под заказ (от 5 рабочих дней);
- Экспресс доставка в любую точку России;
- Техническая поддержка проекта, помощь в подборе аналогов, поставка прототипов;
- Система менеджмента качества сертифицирована по Международному стандарту ISO 9001;
- Лицензия ФСБ на осуществление работ с использованием сведений, составляющих государственную тайну;
- Поставка специализированных компонентов (Xilinx, Altera, Analog Devices, Intersil, Interpoint, Microsemi, Aeroflex, Peregrine, Syfer, Eurofarad, Texas Instrument, Miteq, Cobham, E2V, MA-COM, Hittite, Mini-Circuits, General Dynamics и др.);

Помимо этого, одним из направлений компании «ЭлектроПласт» является направление «Источники питания». Мы предлагаем Вам помощь Конструкторского отдела:

- Подбор оптимального решения, техническое обоснование при выборе компонента;
- Подбор аналогов;
- Консультации по применению компонента;
- Поставка образцов и прототипов;
- Техническая поддержка проекта;
- Защита от снятия компонента с производства.



#### Как с нами связаться

**Телефон:** 8 (812) 309 58 32 (многоканальный)

**Факс:** 8 (812) 320-02-42

**Электронная почта:** [org@eplast1.ru](mailto:org@eplast1.ru)

**Адрес:** 198099, г. Санкт-Петербург, ул. Калинина, дом 2, корпус 4, литера А.