

Package: T-Package, 12.7mm x 12.7mm x 3.96mm

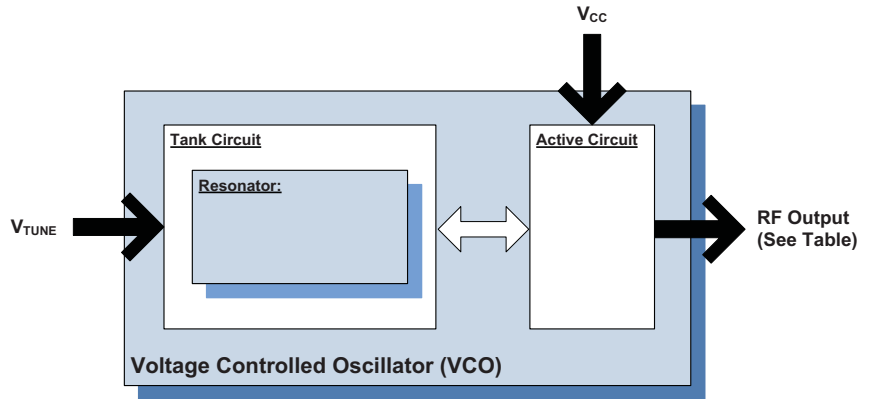

Features

- Linear Tuning/Low Phase Noise
- Multiple Supply Voltage and Package Options Available
- Low-Cost/High-Volume Series
- Frequency: 2850MHz to 3000MHz
- Resonator: Aircoil or Microstrip
- PCB: FR-4 and S1170
- Package Size: 12.7mm x 12.7mm x 3.96mm (0.5in x 0.5in x 0.156in)



Functional Block Diagram

Applications

- Wireless Infrastructure
- RFID
- General Wireless

Product Description

This series of narrowband, low-cost, 5V VCO modules offers linear tuning across their specified frequency band.

Ordering Information

VC0190-2925TY Contact us at 1-480-756-6070

Optimum Technology Matching® Applied

- | | | | |
|--------------------------------------|--------------------------------------|--|------------------------------------|
| <input type="checkbox"/> GaAs HBT | <input type="checkbox"/> SiGe BiCMOS | <input type="checkbox"/> GaAs pHEMT | <input type="checkbox"/> GaN HEMT |
| <input type="checkbox"/> GaAs MESFET | <input type="checkbox"/> Si BiCMOS | <input type="checkbox"/> Si CMOS | <input type="checkbox"/> BiFET HBT |
| <input type="checkbox"/> InGaP HBT | <input type="checkbox"/> SiGe HBT | <input checked="" type="checkbox"/> Si BJT | <input type="checkbox"/> LDMOS |

RF MICRO DEVICES®, RFMD®, Optimum Technology Matching®, Enabling Wireless Connectivity™, PowerStar®, POLARIS™ TOTAL RADIO™ and UltimateBlue™ are trademarks of RFMD, LLC. BLUETOOTH is a trademark owned by Bluetooth SIG, Inc., U.S.A. and licensed for use by RFMD. All other trade names, trademarks and registered trademarks are the property of their respective owners. ©2012, RF Micro Devices, Inc.

Absolute Maximum Ratings

Parameter	Rating	Unit
Operating Ambient Temperature	-40 to +85	°C
Storage Temperature	-55 to +125	°C



Caution! ESD sensitive device.

Exceeding any one or a combination of the Absolute Maximum Rating conditions may cause permanent damage to the device. Extended application of Absolute Maximum Rating conditions to the device may reduce device reliability. Specified typical performance or functional operation of the device under Absolute Maximum Rating conditions is not implied.

The information in this publication is believed to be accurate and reliable. However, no responsibility is assumed by RF Micro Devices, Inc. ("RFMD") for its use, nor for any infringement of patents, or other rights of third parties, resulting from its use. No license is granted by implication or otherwise under any patent or patent rights of RFMD. RFMD reserves the right to change component circuitry, recommended application circuitry and specifications at any time without prior notice.



RoHS (Restriction of Hazardous Substances): Compliant per EU Directive 2002/95/EC.

Parameter	Specification			Unit	Condition
	Min.	Typ.	Max.		
Overall					
Frequency Range	2850		3000	MHz	
Tuning Voltage	1	2		V _{DC}	2850MHz
		8	10	V _{DC}	3000MHz
Tuning Sensitivity	15	30	40	MHz/V	
Output Power	2	5	8	dBm	
Output Phase Noise		-122	-116	dBc/Hz	100kHz
Harmonic Suppression		-15	-10	dBc	2nd harmonic
		-20	-10	dBc	3rd harmonic
Spurious (Non-Harmonic)			-90	dBc	
Frequency Pushing		1	3	MHz p-p	4.9V to 5.1V
Frequency Pulling		3	5	MHz p-p	12dB RL
Tuning Port Capacitance		15		pF	
Output Impedance		50		Ω	
Power Supply					
Operating Voltage	4.9	5	5.1	V	
Supply Current		15	40	mA	

Package Drawing & Pin Outs

12.7mm x 12.7mm x 3.96mm (0.5in x 0.5in x 0.156in)

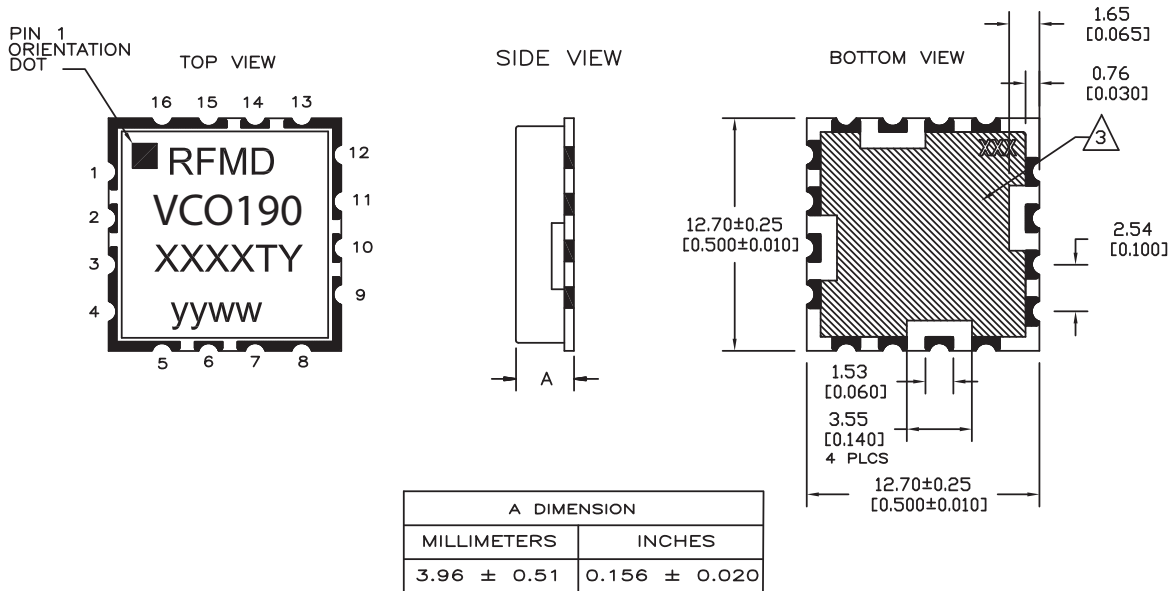

PIN OUT FOR VCO	
PIN	APPLICATION
2	Vt
6	MODULATION (OPT)
10	RF OUT
14	VCC

ALL OTHER PINS ARE GROUND

NOTE, UNLESS OTHERWISE SPECIFIED:

1. THE METAL CASE IS GROUND.
2. ALL HALF VIA CONTACTS ARE PLATED THRU FROM THE PAD ON THE TOP SIDE TO THE PAD ON THE BOTTOM SIDE OF THE BOARD.
3. HATCHED AREAS ARE GROUND AND ARE COVERED WITH LPI SOLDER MASK OVER BARE COPPER. ALL CONTACT AREAS ARE PLATED. SIGNAL VIAS MAY BE LOCATED WITHIN GROUND PLANE.
4. CROSS HATCHED AREA INDICATES AREA WHERE SOLDER MASK SHOULD BE APPLIED TO MOUNTING BOARD.
5. XXXX REPRESENTS THE MODEL NUMBER.
6. yyww IS THE DATE CODE.
7. Y AT THE END OF THE MODEL NUMBER DESIGNATES RoHS COMPLIANCE.
8. DIMENSIONS ARE IN MILLIMETERS AND [INCHES].



Компания «ЭлектроПласт» предлагает заключение долгосрочных отношений при поставках импортных электронных компонентов на взаимовыгодных условиях!

Наши преимущества:

- Оперативные поставки широкого спектра электронных компонентов отечественного и импортного производства напрямую от производителей и с крупнейших мировых складов;
- Поставка более 17-ти миллионов наименований электронных компонентов;
- Поставка сложных, дефицитных, либо снятых с производства позиций;
- Оперативные сроки поставки под заказ (от 5 рабочих дней);
- Экспресс доставка в любую точку России;
- Техническая поддержка проекта, помощь в подборе аналогов, поставка прототипов;
- Система менеджмента качества сертифицирована по Международному стандарту ISO 9001;
- Лицензия ФСБ на осуществление работ с использованием сведений, составляющих государственную тайну;
- Поставка специализированных компонентов (Xilinx, Altera, Analog Devices, Intersil, Interpoint, Microsemi, Aeroflex, Peregrine, Syfer, Eurofarad, Texas Instrument, Miteq, Cobham, E2V, MA-COM, Hittite, Mini-Circuits, General Dynamics и др.);

Помимо этого, одним из направлений компании «ЭлектроПласт» является направление «Источники питания». Мы предлагаем Вам помощь Конструкторского отдела:

- Подбор оптимального решения, техническое обоснование при выборе компонента;
- Подбор аналогов;
- Консультации по применению компонента;
- Поставка образцов и прототипов;
- Техническая поддержка проекта;
- Защита от снятия компонента с производства.



Как с нами связаться

Телефон: 8 (812) 309 58 32 (многоканальный)

Факс: 8 (812) 320-02-42

Электронная почта: org@eplast1.ru

Адрес: 198099, г. Санкт-Петербург, ул. Калинина, дом 2, корпус 4, литера А.